

Prepared for:  
**Tronox LLC**  
**Henderson, Nevada**

# Standard Operating Procedures, Tronox Facility, Henderson, Nevada

ENSR Corporation  
September 2006  
Document No.: 4020-023-101

Prepared for:  
**Tronox LLC**  
**Henderson, Nevada**

# Standard Operating Procedures

ENSR Corporation  
September 2006  
Document No.: 4020-023-101

# TRONOX

Susan Crowley  
Staff Environmental Specialist

(702) 651-2234  
Fax (405) 302-4607  
susan.crowley@tronox.com

September 28, 2006

Mr. Brian Rakvica, P.E.  
Nevada Division of Environmental Protection  
1771 East Flamingo, Suite 121-A  
Las Vegas, NV 89119-0837

Subject: NDEP Facility ID H-000539 – Tronox LLC ECA – QAPP and SOP for Field Sampling

Dear Mr. Rakvica:

Tronox LLC (Tronox) has undertaken an Environmental Conditions Assessment (ECA) as directed by Nevada Division of Environmental Protection (NDEP). Please find attached a Quality Assurance Project Plan (QAPP) and associated Standard Operating Procedures (SOP's), which covers field sampling (both soil and groundwater) to be completed at the Henderson site.

Feel free to call either Keith Bailey (405) 775-6526 or me at (702) 651-2234 if you have any questions regarding this correspondence. Thank you.

Sincerely,



Susan Crowley  
Staff Environmental Specialist, CEM 1428 exp 3-8-07

Overnight Mail

CC: See Attached Distribution List

smc/Trx to NDEP - 9-29-06 re Delivery of QAPP n SOPs.doc

Tronox LLC

8000 West Lake Mead Parkway, Henderson, Nevada 89015 • P.O. Box 55, Henderson, Nevada 89009

**Tronox Document Distribution List**

Updated: 26-Sep-06

**Document Name:** ECA General Docs \*

\* If docs are small then e-versions will not be produced and all will be distributed a hard copy

| Name                   |         | Firm          | Distribution |        |          |
|------------------------|---------|---------------|--------------|--------|----------|
| (Last, First)          |         |               | Hard         | e-Copy | Cvr Only |
| Croft                  | Todd    | NDEP          |              | X      |          |
| King                   | Val     | NDEP          |              | X      |          |
| Najima                 | Jim     | NDEP          |              | X      |          |
| Rakvica                | Brian   | NDEP          | 2            | 2      |          |
| Sous                   | Nadir   | NDEP          |              |        |          |
| Tinney                 | Al      | NDEP          |              | X      |          |
| Palm                   | Jon     | NDEP          |              | X      |          |
| Pohlmann               | Brenda  | COH           |              | X      |          |
| Conaty                 | Barry   | COH Counsel   |              | X      |          |
| Durr                   | Paul    | DAQEM         |              |        |          |
| Hunsaker               | Ross    | DAQEM         |              |        |          |
| Beckstead              | Richard | DAQEM         |              |        |          |
| Jorgenson              | Carolyn | DAQEM Counsel |              |        |          |
| Mrowka                 | Rob     | CCCP          |              | X      |          |
| Mulroy                 | Pat     | SNWA          |              |        |          |
| Goff                   | Mike    | SNWA          |              |        |          |
| Liesing                | Joe     | SNWA          |              |        |          |
| Kaplan                 | Mitch   | EPA, Reg 9    |              | X      |          |
| Compliance Corrdonator |         | NDEP          |              |        |          |
| Compliance Coordinator |         | DAQEM         |              |        |          |
| Public Repository      |         | Library       | X            |        |          |

| Name          |          | Firm             | Distribution |        |          |
|---------------|----------|------------------|--------------|--------|----------|
| (Last, First) |          |                  | Hard         | e-Copy | Cvr Only |
| Bailey        | Keith    | Tronox           | X            | X      |          |
| Corbett       | Pat      | Tronox           |              | X      |          |
| Elmer         | Dana     | Tronox           |              | X      |          |
| Hatmaker      | John     | Tronox           |              | X      |          |
| Reed          | Tom      | Tronox           | X            | X      |          |
| Ellington     | Toni     | Tronox Counsel   |              | X      |          |
| Stater        | Rick     | Tronox           |              | X      |          |
| Crowley       | Susan    | Tronox           | 2            | 2      |          |
|               |          |                  | & Hard Data  |        |          |
| Krish         | Ed       | ENSR             | X            | X      |          |
| Bilodeau      | Sally    | ENSR             | X            | X      |          |
| Gerry         | Dave     | ENSR             |              | X      |          |
| Lambeth       | Jeff     | Veolia           |              |        |          |
| Cheung        | Mary     | Veolia           |              |        |          |
| Guerriero     | Joe      | AIG              |              | X      |          |
| Giroux        | Barry    | GEI              |              | X      |          |
| Stowers       | Kirk     | Broadbent        |              |        |          |
| Quillian      | Jill     | ERM              |              |        |          |
| Sahu          | Rahnijit | BMI              |              | X      |          |
| Crouse        | George   | Syngenta         |              | X      |          |
| Erickson      | Lee      | Stauffer         |              | X      |          |
| Kelly         | Joe      | Montrose         |              |        |          |
| Sundberg      | Paul     | Montrose         |              | X      |          |
| Gibson        | Jeff     | AmPac            |              |        |          |
| Sylvia        | Chris    | Pioneer          |              | X      |          |
| Wilkinson     | Craig    | Timet            |              | X      |          |
| Mack          | Joel     | Montrose Counsel |              |        |          |

**Table of Contents**  
**Standard Operating Procedures**  
Tronox Facility  
Henderson, Nevada

| <b>Tab Number</b> | <b>SOP Number</b> | <b>Title</b>  |
|-------------------|-------------------|---|
| 1                 | 7110-04020        | Surface Soil Sampling                                     |
| 2                 | 7111-04020        | Soil Sampling Matrices for VOCs Using EnCore™ Sampler     |
| 3                 | 7115-04020        | Subsurface Soil Sampling by Split Spoon                   |
| 4                 | 7116-04020        | Subsurface Soil Sampling by Geoprobe™ Methods             |
| 5                 | 7124-04020        | Field Measurement of Water Quality Parameters             |
| 6                 | 7130-04020        | Groundwater Sample Collection from Monitoring Wells       |
| 7                 | 7131-04020        | Field Filtration of Water Samples for Inorganics          |
| 8                 | 7221-04020        | Monitoring Well Development                               |
| 9                 | 7230-04020        | Test Pits/Trench Subsurface Exploration                   |
| 10                | 7315-04020        | Operation/Calibration of a Photoionization Detector (PID) |
| 11                | 7510-04020        | Packaging and Shipment of Environmental Samples           |
| 12                | 7515-04020        | Recording of Field Data                                   |
| 13                | 7600-04020        | Decontamination of Field Equipment                        |
| 14                | 7720-04020        | Hydraulic Conductivity Tests – Pressure Transducer Method |

SOP NUMBER: 7110-04020

## Surface Soil Sampling

**Date:** September 22, 2006  
**Revision Number:** 2  
**Author:** Sally Bilodeau  
**Discipline:** Geosciences

### 1.0 PURPOSE AND APPLICABILITY

#### 1.1 Purpose and Applicability

This standard operating procedure (SOP) describes the methods used for obtaining surface soil samples for physical and/or chemical analysis. For purposes of this SOP, surface soil (including shallow subsurface soil) is loosely defined as soil that is present within 5 feet of the ground surface and can be sampled with the use of readily available and easy-to-operate sampling equipment. Various types of sampling equipment are used in the collection of surface soil samples and include spoons or scoops, trowels, shovels, and hand or bucket augers.

The purpose of this SOP is to provide a specific method and/or procedure to be used in the collection of surface soil samples which, if followed properly, will promote consistency in sampling and provide a basis for sample representativeness.

This SOP is generally applicable to surface and shallow depth soils that are unconsolidated and are of low to moderate density. Higher density or compacted soils may require use of drill rigs or other powered equipment to effectively obtain representative samples.

It should be noted that other specific state and/or federal agency SOPs may be in existence in certain areas, which may require deviation from this sampling procedure. The applicability of other agency operating procedures, which may differ from ENSR's SOP, needs to be determined prior to start of the sampling program. Deviations from this SOP to accommodate other regulatory requirements should be reviewed in advance of the field program, should be explained in the project work plan, and must be documented in the field project logbook when they occur.

#### 1.2 General Principles

Surface soil sampling generally involves use of hand-operated equipment to obtain representative soil samples from the ground surface and to shallow depths below the ground surface. If soil conditions are appropriate, surface soil sampling, following the procedures described in this SOP, can provide representative soil samples in an efficient manner.

#### 1.3 Quality Assurance Planning Considerations

Project personnel should follow specific quality assurance guidelines for sampling as outlined in the site-specific Quality Assurance Project Plan (QAPP) and/or Sampling Plan. Proper quality assurance requirements should be provided that will allow for collection of representative

samples from representative sampling points. Quality assurance requirements typically suggest the collection of a sufficient quantity of field duplicate, field blank, and equipment blank samples.

#### **1.4 Health and Safety Considerations**

Surface soil sampling may involve chemical exposure hazards associated with the type of contaminants present in surface soil and physical hazards associated with the use of the hand-operated sampling equipment. When surface soil sampling is performed, adequate Health and Safety measures must be taken to protect sampling personnel. These measures must be addressed in the project Health and Safety Plan (HASP). This plan must be approved by the project Health and Safety Officer before work commences, must be distributed to all personnel performing sampling, and must be adhered to as field activities are performed.

### **2.0 RESPONSIBILITIES**

#### **2.1 Sampling Personnel**

It will be the responsibility of the sampling personnel to conduct surface soil sampling in a manner consistent with this SOP. The above individual will be responsible for the proper use and maintenance of all types of equipment used for obtaining surface soil samples, and the collection, labeling, handling, and storage of all samples until further chain-of-custody procedures are undertaken.

#### **2.2 Sampling Coordinator**

Large sampling programs may require additional support personnel such as a sampling coordinator. The sampling coordinator is responsible for providing management support such as maintaining an orderly sampling process, providing instructions to sampling personnel regarding sampling locations, and fulfilling sample documentation requirements, thereby allowing sampling personnel to collect samples in an efficient manner.

#### **2.3 Project Manager**

It is the responsibility of the project manager to ensure that the sampling activity is properly staffed, planned, and executed.

### **3.0 REQUIRED MATERIALS**

#### **3.1 Spoons or Scoops**

Spoons or scoops should preferably be constructed of stainless steel as this material is abrasion resistant, can be easily decontaminated, and can be used to manually extract low to moderate density soil samples directly from the ground surface. Other spoon/scoop construction materials such as high-density polyethylene (HDPE) and Teflon may be suitable in some applications but are difficult to use in higher density soils.

### 3.2 Trowel

Trowels should preferably be constructed of stainless steel. The blade of a trowel is generally flat or slightly curved and is 5 to 6 inches in length. Some trowels are available with depth calibrations marked on the blade.

### 3.3 Shovel

Shovels may be long or short-handled and are most often used for preparation of the sample collection area (i.e., for removal of surface debris or penetration of a high density/compacted surface prior to collection of the sample with another more appropriate device). Shovels may be used for the collection of samples that require large volumes of material for analysis (i.e., for bench-scale treatability studies). Shovels can also be used for scraping of test pit sidewalls in preparation for sidewall sampling using another device.

### 3.4 Hand Auger

This tool, commonly referred to as a soil auger, consists of a short spiral-bladed metal rod (solid-stem auger) attached to a handle. Clockwise rotation of the handle provides the cutting motion for the auger. Most of the loose soil is discharged upwards as the auger moves downwards. However, if the soil is cohesive, some of it will stick to the auger flight providing a collectable sample at a measurable depth. Samples of surface soil can also be collected using a tube sampler that is attached to the end of the auger rods and advanced into the soil to extract a sample.

### 3.5 Bucket Auger

This device consists of a short length of hollow tube with cutting teeth at the bottom. As the handle is rotated, the sample is brought into and retained within the tube. When the auger is removed from the ground surface, the sample is retrieved from the tube with a spoon, or, if loosely consolidated, is poured directly into a collection pan or into the sample containers. Typically constructed of stainless steel, bucket augers are commonly available in diameters varying from 2 to 4 inches.

### 3.6 Collection Pan

A soil collection pan is often used as an intermediate sample container between removal of the sample from the ground and final bottling of the sample. Soil collection pans should preferably be constructed of stainless steel, although common household steel cooking pans may be used if the pan is lined with aluminum foil during sample collection.

### 3.7 Supporting Materials

- Teaspoon or spatula
- Aluminum foil
- Sample kit (i.e., bottles, labels, custody records, cooler, etc.)



- Sample logs/boring logs
- Decontamination materials
- 6-foot folding rule or tape measure for depth measurement
- Personal protective equipment (as required by the HASP)
- Field project logbook/pen

## 4.0 METHOD

### 4.1 General Procedures

Site-specific soil characteristics, such as soil density and moisture, will generally dictate the preferred type of sampling equipment for use at a particular site. Similarly, other project-specific requirements, such as sampling depth, and requested type of analysis, such as physical testing (e.g., grain-size distribution), and/or chemical analysis will dictate the use of a preferred type of sampling equipment. Analytical testing requirements will indicate sample volume requirements that also will influence the selection of the appropriate type of sampling tool. The project sampling plan should define the specific requirements for collection of surface soil samples at a particular site. Should site-specific characteristics remain unidentified prior to start of the sampling program, sampling personnel should be equipped with a variety of sampling equipment to address the most likely sampling situations to be encountered.

As indicated, sample volume and sampling depth requirements should be defined in the sampling plan. This information should define the size of the hole that will be created during collection of the sample. For instance, if only a 500-milliliter sample will be required for analysis from a depth interval of 0 to 6 inches, an approximate 2- to 3-inch diameter hole will be needed. The indicated types of sampling equipment will generally make a minimum diameter hole of approximately 3 inches; therefore, an excess volume of soil may be generated during collection of a small volume soil sample. For samples requiring a large volume of soil, multiple holes and soil compositing may be necessary. Collection of the requisite volume of soil to meet sample volume requirements without underestimating the sample volume is the overall objective and is a technique that improves with experience.

It should be noted that some sampling programs may require the use of a sampling grid for the purpose of obtaining a statistically representative number of soil samples. This SOP does not provide information relative to construction of a sampling grid. This information may be found in other documents.

### 4.2 Equipment Decontamination

Regardless of the specific type of equipment used, each piece of equipment needs to be decontaminated prior to its initial use and following collection of each individual soil sample. Site-specific requirements for equipment decontamination should be outlined within the project sampling plan. Equipment decontamination procedures are specified within ENSR 7600-04020 - Decontamination of Equipment.

### 4.3 Collection of Samples for Volatile Organics Analysis

Collection of surface soil samples for volatile organics analysis (VOA) is different than collection of soil samples for other routine physical or chemical testing primarily because of the concern for potential loss of volatiles during the normal sample collection procedure. To limit the potential for loss of volatiles, the soil sample must be obtained as quickly and as directly as possible. This generally means that if a VOA sample is to be collected as part of a multiple analyte sample, the VOA sample portion should be obtained first. The VOA sample should also be obtained from a discrete portion of the entire collected sample and not from a sample that has been composited or homogenized from the entire sample interval. In general, it is best to collect the VOA sample by transferring the sample directly from the sampling tool into the sample bottles. Intermediate sample containers such as collection pans should not be used during collection of VOA samples. In general, sample bottles should be filled to capacity, with no headspace, when collecting VOA samples. The specific method for collection of VOA samples using the USEPA Method 5035 is discussed under a separate SOP.

### 4.4 Standard Procedures

#### 4.4.1 Surface Preparation

At some sampling locations, the ground surface may require preparation in advance of sampling. Surface preparation can include removal of surface debris that blocks access to the actual soil surface or loosening of dense surface soils, such as those encountered in heavy traffic areas, or frozen soils. If sampling equipment is used for both removal of surface debris and for collection of the soil sample, the equipment should be decontaminated prior to sample collection to reduce the potential for sample interferences between the surface debris and the underlying soil.

#### 4.4.2 Shovel Sampling Procedure

A detailed operating procedure for proper use of a shovel for soil sampling is unnecessary. Specific requirements for sample quantity and sampling depth should be outlined within the project sampling plan.

Decontaminate the shovel in accordance with established procedures prior to use.

Once the soil sample is obtained and placed into the appropriate sample container(s), the hole from which the sample was retrieved should be filled with surrounding soils to eliminate a potential surface hazard.

#### 4.4.3 Spoon, Scoop, and Trowel Sampling Procedure

Spoons, scoops, and trowels are of similarly designed construction and can therefore be operated in accordance with the following procedure.

Select the sampling location and prepare the surface by removal of surface debris if present. If the sample depth interval is below the ground surface, the surface soil material should also be removed as part of the surface preparation step. Surface preparation should be completed using other appropriately decontaminated sampling equipment.

Decontaminate the sampling tool in accordance with established procedures prior to use.

The soil sample should be obtained by inserting the sampling tool into the ground and rotating the tool so that a representative "column" of soil is removed from the ground.

The immediate objective is to collect the VOA sample fraction first if this is required. If the VOA sample is to be collected from the upper sampling interval, then the first scoop of soil should be used to directly fill the sample containers. If a specific depth below the ground surface has been targeted for the VOA sample, the overlying soils should be removed and discarded or placed into a soil collection pan as part of the remaining composite sample.

Regardless of whether or not a VOA sample is required, one or more cores or scoops of soil may be needed until the desired sampling depth is achieved. Removal of a representative column of soil in cohesionless soils may be difficult to achieve, however. If more soil is needed to meet sample volume requirements, additional soil cores may be collected from an immediately adjacent location.

Except for VOA samples, as each portion of the sample is removed from the ground, it should be placed into an intermediate sample container (collection pan) until the entire sample interval of soil is removed.

Once the sample interval has been collected, the soil sample should be thoroughly homogenized within the collection pan prior to bottling. Sample homogenizing is accomplished by manually mixing the entire soil sample in the collection pan with the sampling tool or with a clean teaspoon or spatula until a uniform mixture is achieved.

The appropriate sample containers should be filled with soil from the collection pan. The sampling tool may be used to fill the sample bottles. If packing of the samples into the bottles is necessary, a clean stainless steel teaspoon or spatula may be used. Use of fingers/hands to fill or pack sample containers should be avoided (this also includes VOA samples).

Once each sample container is filled, the rim and threads of the sample container will be cleaned of gross soil by wiping with a paper towel, then capped and labeled. Do not submerge the sample containers in water to clean them. Once labeled the sample containers should be placed into a cooler for protection. Sample chain-of-custody forms and other documentation requirements should be completed at this time.

The sampling tool and other sampling equipment should be decontaminated prior to reuse. All investigation-derived waste should be properly contained before leaving the area.

The sample hole should be backfilled to eliminate any surface hazard. The project sampling plan may indicate the requirements for backfilling of the sample hole.

#### 4.4.4 Hand Auger Sampling

Select the sampling location and prepare the surface by removal of surface debris if present.

Decontaminate the sampling tool in accordance with established procedures prior to use.

A hand auger, or soil auger, can be used to extract soil samples up to about 15 below the surface or until refusal in hard ground. Representative samples can be collected directly from the auger flight as it is withdrawn from the ground or from the tube sampler attachment, which can be advanced into the soil after augering to the desired depth.

When using the hand auger, the hole should be augered to the required depth by manually pushing and turning the auger. As the auger is turned, soils will be discharged to the ground surface, although some soil will be retained on the auger flight. Augering should be continued until the desired depth is achieved. If a composite or homogenized soil sample is the objective, those soils that have been discharged to the ground surface as well as those soils that cling to the auger flight should be homogenized within a soil collection pan prior to bottling. If a VOA sample is required, this fraction of the soil sample should be collected as soon as possible without compositing. It should be noted that soil augers cause considerable disturbance of the soil; therefore, some consideration should be given toward collection of VOA sample fractions using some other method (spoons, trowels, or bucket augers may cause less disturbance).

Except for VOA sample fractions, the remainder of the soil sample should be thoroughly homogenized in the soil collection pan prior to bottling.

The appropriate sample containers should be filled with soil from the collection pan. A clean spoon or spatula may be needed to fill the sample bottles as necessary.

Once each sample container is filled, the rim and threads of the sample container will be cleaned of gross soil by wiping with a paper towel, then capped and labeled. Do not submerge the sample containers in water to clean them. Once labeled the sample containers should be placed into a cooler for protection. Sample chain-of-custody forms and other documentation requirements should be completed at this time.

All used sampling equipment should be decontaminated prior to reuse and investigation-derived waste should be properly contained before leaving the area.

The sample hole should be backfilled to eliminate any surface hazard. The project sampling plan may indicate the requirements for backfilling of the sample hole.

#### 4.4.5 Bucket Auger Sampling

A bucket auger may be used to collect soil samples from depths ranging from 1 to approximately 5 feet. In some instances, soil samples may be collected from greater depths, but often with considerable more difficulty. Bucket augers allow for discrete depth interval sampling as the soil is retained within the hollow tube of the auger when it is extracted from the ground. It should be noted that if depth-discrete sampling is the objective, more than one auger may be necessary, with one auger used to provide access to the required sampling depth and the other (clean) auger used for sample collection.

Select the sampling location and prepare the surface by removal of surface debris, if present.

Decontaminate the sampling tool in accordance with established procedures prior to use.

When using the bucket auger, the auger should be pushed downward and rotated until the bucket becomes filled with soil. Usually a 6- to 12-inch core of soil is obtained each time the auger is inserted. Once filled, the auger should be removed from the ground and emptied into the soil collection pan. If a VOA sample is required, the sample should be taken directly from the auger using a teaspoon or spatula and/or directly filling the sample container from the auger. The augering process should be repeated until the desired sample interval has been augered and placed into the collection pan.

If the desired sample interval is located at a specific depth below the ground surface, the unwanted interval can be removed with one auger and the soil discarded. Sample collection can then proceed in normal fashion using a clean auger or following decontamination of the original auger.

Except for VOA sample fractions, the remainder of the soil sample should be thoroughly homogenized in the soil collection pan prior to bottling.

The appropriate sample containers should be filled with soil from the collection pan. Once each sample container is filled, the rim and threads of the sample container will be cleaned of gross soil by wiping with a paper towel, then capped and labeled. Do not submerge the sample containers in water to clean them. Once labeled the sample containers should be placed into a cooler for protection. Sample chain-of-custody forms and other documentation requirements should be completed at this time.

All used sampling equipment should be decontaminated prior to reuse and investigation-derived waste should be properly contained before leaving the area.

The sample hole should be backfilled to eliminate any surface hazard. The project sampling plan may indicate the requirements for backfilling of the sample hole.

## 5.0 QUALITY CONTROL

Quality control requirements for sample collection are dependent on project-specific sampling objectives. The QAPP will provide requirements for sample preservation and holding times, container types, sample packaging and shipment, as well as requirements for the collection of various quality assurance samples such as trip blanks, field blanks, equipment blanks, and field duplicate samples.

## 6.0 DOCUMENTATION

Various forms are required to ensure that adequate documentation is made of the sample collection activities. These forms include:

- Field logbooks
- Sample collection records
- Chain-of-custody forms
- Shipping labels

The field logbook will be maintained as an overall log of all samples collected throughout the study. Sample collection records are generated for each sample collected and include specific information about the sample (Figure 1). Chain-of-custody forms are transmitted with the samples to the laboratory for sample tracking purposes. Shipping labels are required if sample coolers are to be transported to the laboratory by a third party (courier service). Original and/or copies of these documents will be retained in the appropriate project files.

## 7.0 TRAINING/QUALIFICATIONS

Surface soil sampling is a relatively simple procedure requiring minimal training and a relatively small amount of equipment. It is, however, recommended that initial attempts be supervised by more experienced personnel. Sampling personnel should be health and safety certified as specified by the Occupational Safety and Health Administration [OSHA; 29 CFR 1910.120(e)(3)(i)] to work on sites where hazardous materials may be present.

## 8.0 REFERENCES

Not applicable.

**FIGURE 1 Surface Soil Sample Log**



**SURFACE SOIL SAMPLE LOG**

Project Number: \_\_\_\_\_ Project Location: \_\_\_\_\_

Sample Point No.: \_\_\_\_\_

Date: \_\_\_\_\_ Time: \_\_\_\_\_

Sample Point Description/Designation: \_\_\_\_\_

---



---



---

**SAMPLE COLLECTION**

Equipment Used: \_\_\_\_\_

No. of Samples Collected: \_\_\_\_\_ Container Size: \_\_\_\_\_

| Sample Number | Depth | Type of Material | Analyses Requested |
|---------------|-------|------------------|--------------------|
|               |       |                  |                    |
|               |       |                  |                    |
|               |       |                  |                    |
|               |       |                  |                    |
|               |       |                  |                    |
|               |       |                  |                    |
|               |       |                  |                    |
|               |       |                  |                    |
|               |       |                  |                    |
|               |       |                  |                    |

**Comments:**

Lab Designation \_\_\_\_\_

Shipping ID Number: \_\_\_\_\_

Collector's Name \_\_\_\_\_

SOP NUMBER: 7111-04020

## Sampling of Solid Matrices for VOCs Using EnCore™ Sampler

**Date:** September 22, 2006  
**Revision Number:** 1  
**Author:** Sally Bilodeau  
**Discipline:** Geoscience

### 1.0 PURPOSE & APPLICABILITY

Volatile organic compounds (VOCs) in soils/sediments/solids have traditionally been collected by placing the sample in a vial or jar with minimal headspace and keeping it cool. Update III to SW-846 (specifically Methods 5021 and 5035), published in June 1997, deleted this technique and requires that solid VOC samples be either collected as field-preserved samples or collected in single-use samplers specifically designed for this purpose (EnCore™) samplers or equivalent).

This procedure describes the collection of soil, sediments, or other solid matrices using the EnCore™ samplers. EnCore™ samplers are generally preferred over field preservation due to difficulties in handling and transporting the preservatives. The single-use, disposable EnCore™ sampler is constructed of an inert composite polymer and consists of three components: the coring body, the plunger, and the airtight sealing cap. An attachable, reusable T-handle is used to assist in pushing the sampler into the soil or sediment.

Under certain conditions, the use of EnCore™ samplers may not be appropriate and field preservation may be required. Section 4.9 of this SOP describes field preservation procedures.

In general, the use of EnCore™ samplers and/or field preservation is applicable to work being conducted under SW-846 methodologies. It is not required under Contract Laboratory Program (CLP) methodologies. Individual states or other regulatory agencies may also mandate alternative methods.

### 2.0 RESPONSIBILITIES

- 2.1** The Project Manager is responsible for determining the methods that are appropriate to achieve the project objectives and for supplying the necessary resources to meet those objectives.
- 2.2** The field sampling team leader or task manager is responsible for ensuring that this procedure is followed in collecting the samples.
- 2.3** Field personnel are responsible for collecting samples in accordance with this procedure and providing sufficient documentation of sample collection and related field activities.

### 3.0 REQUIRED MATERIALS

- Clean polyethylene sheeting



- Clean gloves (the composition of the gloves depends on the material being sampled – refer to the project-specific Quality Assurance Project Plan [QAPP] and Health and Safety Plan [HASP])
- EnCore™ samplers\* (one to three for each sample to be collected, depending on project objectives)
- Separate container for dry weight determination (see 4.7)
- Calibrated photoionization detector (PID) or flame ionization detector (FID)
- Chemical-free towelettes
- Ice and appropriate packing materials for transport of samples to the laboratory;
- Personal protective equipment (PPE) as required by the HASP
- Optional Materials
  - Portable field balance capable of weighing to 0.1g
  - Balance calibration weights
  - Pre-preserved vials (to be provided by the laboratory)

\* EnCore™ samplers may be obtained from the laboratory or ordered directly from the manufacturer, En Novative Technologies, Inc. (1-888-411-0757)

#### 4.0 METHOD

For each sample location, collect soil samples using the following procedure:

- 4.1 Create a clean workspace using clean polyethylene sheeting.
- 4.2 Put on clean gloves immediately before sampling.
- 4.3 Remove the EnCore™ sampler from its resealable package.
- 4.4 Attach the EnCore™ sampler to the T-handle according to the manufacturer's instructions (see Figure 1), as follows:
  - 4.4.1 Holding the coring body, push the plunger rod down until the small o-ring rests against the tabs, allowing the plunger to move freely.
  - 4.4.2 Depress the locking lever on the T-handle.
  - 4.4.3 Place the coring body, plunger end first, into the open end of the T-handle, aligning the two slots on the coring body with the two locking pins in the T-handle.
  - 4.4.4 Twist the coring body clockwise to lock the pins into the slots.
  - 4.4.5 Check to ensure that the sampler is locked into place.
- 4.5 Insert the coring body into the resealable package while preparing the sampling implement.

Upon exposure of the soil within the sampling implement and headspace screening (if appropriate) with the PID/ FID, collect the samples immediately using the following procedure

(NOTE: headspace screening should be performed after collection of the EnCore™ samples):

- 4.5.1** Turn the T-handle with the T up and the coring body down, positioning the plunger bottom flush with the bottom of the coring body. Visually inspect to ensure that the plunger bottom is in this position.
  - 4.5.2** Using the T-handle, push the sampler into the soil. Retrieve the sampler and check to ensure that the coring body is completely full (i.e., the small o-ring will be centered in the T-handle viewing hole). If the sampler is not full, repeat the process until the sampler is full. The sampler will not seal until it is completely full. In order to minimize loss of VOCs, the sampler is to be loaded in a manner that minimizes disturbance of the soil being sampled.
  - 4.5.3** Wipe excess sample material from the outside of the sampler using a chemical-free towelette.
  - 4.5.4** Cap the coring body while still attached to the T-handle. Push and twist the cap over the bottom until the grooves on the locking arms seat over the edge on the coring body. The cap must be seated to seal the sampler.
  - 4.5.5** Remove the capped sampler by depressing the locking lever on the T-handle while twisting and pulling the sampler from the T-handle.
  - 4.5.6** Lock the plunger by rotating the extended plunger rod fully counterclockwise until the wings rest firmly against the tabs.
  - 4.5.7** Complete the detachable label on the resealable package. Detach and attach the label to the cap of the sampler.
  - 4.5.8** Place the sampler in the resealable package, seal the package, and place the sealed package on ice.
- 4.6** The number of EnCore™ samples collected will depend on the project objectives and the laboratory chosen to perform the analyses. In general, two EnCore™ samplers are required for low-level analysis and one for high-level analysis, for a total of three EnCore™ samplers per sample. Double to triple volume is required for matrix spike/matrix spike duplicate (MS/MSD) analysis.
- 4.7** A separate sample must be collected for dry weight determination. This sample may be collected as an additional EnCore™ or in a 2- or 4-ounce glass jar, depending on laboratory requirements.
- 4.8** The holding time until preservation associated with the EnCore™ samplers is 48 hours from collection. Samples will therefore be shipped daily from the field. Samples will be maintained on ice during sampling and subsequent shipment to the laboratory.

**4.9** Use of the EnCore™ sampler will be restricted to the protocol described above. If the EnCore™ sampler cannot be properly used because of the nature of the material to be sampled (e.g., if the material contains a high water content or is composed of large aggregates), samples will be preserved in the field as follows:

**4.9.1** Using a calibrated portable field balance accurate to 0.1 gram, calibrate a clean, new plastic cut-off syringe by determining the length of the soil/sediment column that relates to 5 grams of sample. Discard the soil/sediment and syringe.

**4.9.2** Collect the low-level sample (if applicable to the project) by quickly taking a 5-gram sample using a clean, new plastic cut-off syringe. Place the sample in a 40-milliliter (mL) vial containing the sodium bisulfate preservative solution, wipe the vial threads with a chemical-free towelette to remove any adhering soil or sediment, and seal the vial. Check for effervescence. If the gas generated is small (several mLs), submit the sample for analysis. If larger amounts of gas are generated, discard the sample and collect the sample in a vial without preservation.

**4.9.3** Repeat the process (two low-level samples will be collected per soil/sediment sample).

**4.9.4** Collect the high-level sample (if applicable to the project) using the same plastic syringe. Quickly collect a 5-gram sample and place it in a 40-mL vial containing the methanol preservative. Wipe the vial threads to remove any adhering soil or sediment and seal the vial. Only one high-level sample will be collected per soil/sediment sample.

**4.9.5** Label each vial and immediately place on ice.

## **5.0 QUALITY CONTROL**

Quality control requirements for sample collection are dependent on project-specific sampling objectives. The QAPP will provide requirements for sample preservation and holding times, container types, sample labeling, sample packaging and shipment, as well as requirements for the collection of various quality assurance samples such as trip blanks, field blanks, equipment blanks, MS/MSDs, and field duplicate samples.

## **6.0 DOCUMENTATION**

Various materials are required to ensure that adequate documentation is made of the sample collection activities. These materials include:

- Field logbooks,
- Sample collection records,
- Chain-of-custody forms,
- Sample labels or tags, and

- Shipping labels.

The field logbook will be maintained as an overall log of all samples collected throughout the study. Sample collection records are generated for each sample collected and include specific information about the sample. Chain-of-custody forms are transmitted with the samples to the laboratory for sample tracking purposes. A sample label or tag is attached to each sample container and includes the unique sample identification number, sampler's initials, and the date and time of sample collection. Shipping labels are required if sample coolers are to be transported to the laboratory by a third party (courier service). Original and/or copies of these documents will be retained in the appropriate project files.

## 7.0 TRAINING/QUALIFICATIONS

Sampling with EnCore™ samplers is a relatively simple procedure requiring minimal training and a relatively small amount of equipment. Initial attempts should be supervised by more experienced personnel to ensure the correct use of the EnCore™ samplers and proper sample handling procedures. Sampling personnel should be health and safety certified as specified by the Occupational Safety and Health Administration [OSHA; 29 CFR 1910.120(e)(3)(i)] to work on sites where hazardous materials may be present.

## 8.0 REFERENCES

United States Environmental Protection Agency; Test Methods for Evaluating Solid Waste, Physical/Chemical Methods (SW-846). On line <http://www.epa.gov/sw-846> (2006)

En Novative Technologies, Inc.; Disposable EnCore™ Sampler Sampling Procedures. En Novative Technologies, Inc., 1241 Bellevue Street, Green Bay, WI 54302

FIGURE 1. EnCore™ Manufacturer's Instruction Sheet

# Disposable EnCore™ Sampler



**En Novative Technologies, Inc.**  
 1241 Bellevue Street  
 Green Bay, WI 54302  
 Telephone: 920-465-3960 • Toll Free: 1-888-411-0757  
 Fax: 920-465-3963

## SAMPLING PROCEDURES

### USING THE EnCore™ T-HANDLE

**NOTE:**

1. En Core Sampler is a **SINGLE USE** device. It cannot be cleaned and/or reused.
2. En Core Sampler is designed to store soil. Do not use En Core Sampler to store solvent or free product!
3. En Core Sampler must be used with En Core™ T-Handle and/or En Core™ Extrusion Tool exclusively. (These items are sold separately.)

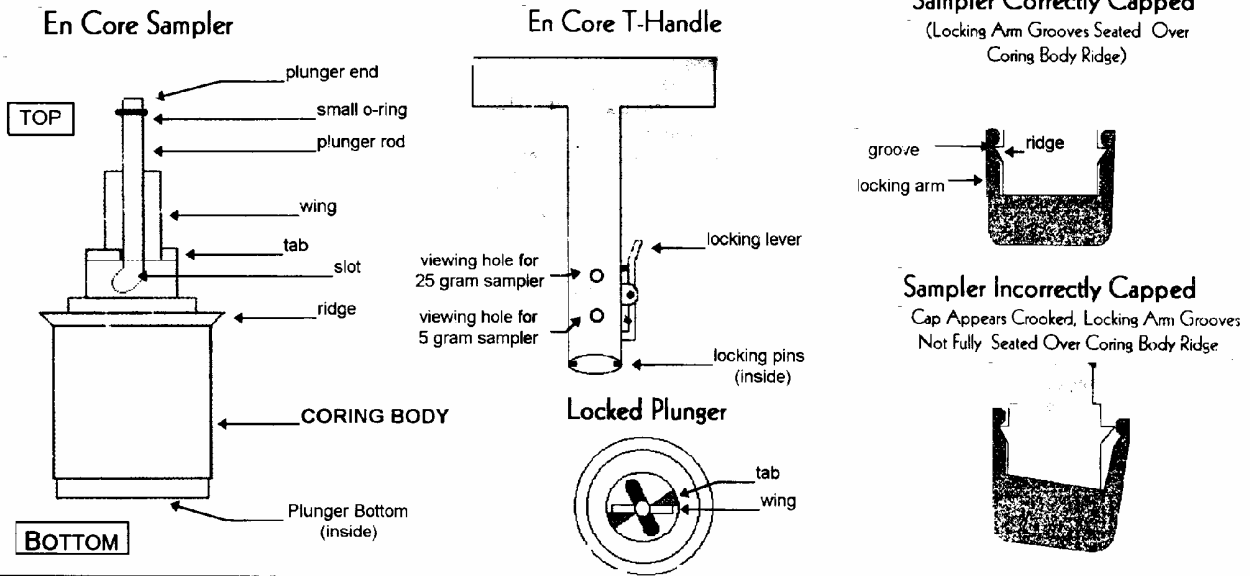

**BEFORE TAKING SAMPLE:**

1. Hold coring body and push plunger rod down until small o-ring rests against tabs. This will assure that plunger moves freely.
2. Depress locking lever on En Core T-Handle. Place coring body, plunger end first, into open end of T-Handle, aligning the (2) slots on the coring body with the (2) locking pins in the T-Handle. Twist coring body clockwise to lock pins in slots. Check to ensure Sampler is locked in place. Sampler is ready for use.

**TAKING SAMPLE:**

3. Turn T-Handle with T-up and coring body down. This positions plunger bottom flush with bottom of coring body (ensure that plunger bottom is in position). Using T-Handle, push Sampler into soil until coring body is completely full. When full, small o-ring will be centered in T-Handle viewing hole. Remove Sampler from soil. Wipe excess soil from coring body exterior.

4. Cap coring body while it is still on T-handle. *Push and twist* cap over bottom until grooves on locking arms seat over ridge on coring body. CAP MUST BE SEATED TO SEAL SAMPLER (see diagram).

**PREPARING SAMPLER FOR SHIPMENT:**

5. Remove the capped Sampler by depressing locking lever on T-Handle while twisting and pulling Sampler from T-Handle.
6. Lock plunger by rotating extended plunger rod fully counter-clockwise until wings rest firmly against tabs (see plunger diagram).
7. Attach completed circular label (from En Core Sampler bag) to cap on coring body.
8. Return full En Core Sampler to zipper bag. Seal bag and put on ice.

**SOP NUMBER: 7115-04020**

**Subsurface Soil Sampling by Split Spoon**

**Date:** September 22, 2006  
**Revision Number:** 4  
**Author:** Sally Bilodeau  
**Discipline:** Geosciences

**1.0 PURPOSE AND APPLICABILITY**

This Standard Operating Procedure (SOP) describes the methods used in obtaining subsurface soil samples using a split-spoon sampler for physical and/or chemical analysis. Subsurface soil samples are obtained in conjunction with soil boring programs and provide information as to the physical and/or chemical makeup of the subsurface environment.

The purpose of this SOP is to provide a description of a specific method or procedure to be used in the collection of subsurface soil samples. Subsurface soil is defined as unconsolidated material that may consist of one or a mixture of the following materials: sand, gravel, silt, clay, peat (or other organic soils), and fill material. Subsurface soil sampling, conducted in accordance with this SOP, will promote consistency in sampling and provide a basis for sample representativeness.

This SOP covers subsurface soil sampling by split spoon only, as this is the means most often used for obtained samples of unconsolidated deposits. Other types of equipment are available for use in subsurface soil sampling, including thin-wall tube samplers (Shelby tubes), piston samplers, and continuous core barrel samplers. Information on the use of these other sampling devices may be found in several available drilling handbooks and respective state and/or federal agency technical guidance documents. The American Society for Testing and Materials (ASTM) also provides procedures for use of split-spoon and other sampling devices.

Deviations from this SOP to accommodate other regulatory requirements should be reviewed in advance of the field program, should be explained in the project work plan, and must be documented in the field project logbook when they occur.

**1.1 General Principles**

Split-spoon subsurface soil sampling generally requires use of a drilling rig and typically the hollow-stem auger or other common drilling method to generate a borehole in which to use the split-spoon sampler. The split-spoon sampler is inserted through the augers (or other type of drill casing), then it is driven into the subsurface soil with a weighted hammer. The sampler is then retrieved and opened to reveal the recovered soil sample. Soil samples may be collected at a continuous interval or at pre-selected vertically spaced intervals within the borehole.

**1.2 Quality Assurance Planning Considerations**

Sampling personnel should follow specific quality assurance guidelines as outlined in the site-specific Quality Assurance Project Plan (QAPP). Proper quality assurance requirements

should be provided that will allow for collection of representative samples from representative sampling points. Quality assurance requirements outlined in the QAPP typically suggest the collection of a sufficient quantity of field duplicate, field blank, and other samples.

### **1.3 Health and Safety Considerations**

Subsurface soil sampling may involve chemical hazards associated with the types of contaminants potentially encountered and will always involve potential physical hazards associated with the use of drilling equipment. When sampling is performed in materials that may contain hazardous constituents, or when the quality assurance objectives of the project require the use of hazardous solvents, adequate Health and Safety measures must be taken to protect sampling personnel. These measures must be addressed in the project Health and Safety Plan (HASP). This plan must be approved by the project Health and Safety Officer before work commences, must be distributed to all personnel performing sampling, and must be adhered to as field activities are performed.

## **2.0 RESPONSIBILITIES**

### **2.1 Drilling Subcontractor**

It will be the responsibility of the drilling subcontractor to provide the necessary materials for obtaining subsurface soil samples. This generally includes one or more split-spoon samplers in good operating condition and sample containers used for stratigraphic characterization samples (sample containers for environmental samples should be provided by the designated analytical laboratory). It is the drilling subcontractor's responsibility to provide and maintain their own boring logs if desired. Equipment decontamination materials should also be supplied by the subcontractor and should meet project specifications. The driller is responsible for thorough decontamination of all split-spoon equipment and associated sampling equipment.

### **2.2 Project or Field Geologist/Engineer**

It will be the responsibility of the person in the field, whether it is the project geologist/engineer or the field geologist/engineer, to conduct subsurface soil sampling in a manner that is consistent with this SOP. The geologist/engineer will observe all activities pertaining to subsurface soil sampling to ensure that the SOP is followed and to record all pertinent data onto a boring log. It is also the geologist/engineer's responsibility to indicate the specific targeted sampling depth or sampling interval to the drilling subcontractor. The geologist/engineer is also responsible for the collection of representative environmental or stratigraphic characterization samples once the sampling device has been retrieved and opened. Additional sample collection responsibilities include labeling, handling, and storage of samples until further chain-of-custody procedures are implemented. The geologist/engineer is also responsible for observing and inspecting equipment that is used to sample or that comes into contact with the ground to verify that it appears clean and adequately decontaminated consistent with site-specific requirements.

### 3.0 REQUIRED MATERIALS

In addition to those materials provided by the subcontractor, the project geologist/sampling engineer will require:

- Project Sampling Plan, QAPP, and HASP
- Boring logs
- Teaspoon or spatula (stainless steel is recommended)
- Sample kit (bottles, labels, custody records and tape, cooler)
- Appropriate pen or other writing instrument that will not be affected by wet conditions.
- Folding rule or tape measure
- Equipment decontamination materials
- Health and safety equipment (as required by HASP)
- Field project logbook/pen

### 4.0 METHOD

#### 4.1 General Method Description

Split-spoon sampling devices are typically constructed of steel and are most commonly available in lengths of 18 and 24 inches and diameters of 1.5 to 3 inches. The split spoon consists of a tubular body with two halves that split apart lengthwise, a drive head on the upper end with a ball-check valve for venting, and a hardened steel cutting shoe at the bottom. The soil sample enters the split spoon through the cutting shoe as the device is driven into the ground. A replaceable plastic or metal basket is often inserted into the shoe to assist with retaining samples. Once the sampler is retrieved, the drive head and cutting shoes are removed and the split spoon halves are then separated, revealing the sample.

Sample depth intervals are usually defined on a project-specific basis with these requirements specified in the Project Sampling Plan. Sampling intervals typically range from 1 sample per 5 feet of drilling to continuous sampling where the entire drilled interval is sampled.

Subsurface soil sampling is usually accomplished as part of a drilling program where a soil boring is advanced with drilling equipment to the designated depth prior to collection of a representative sample. The general procedures outlined briefly in the following section provide requirements for advancing drill casing/augers in preparation for sampling.

#### 4.2 General Procedures – Borehole Preparation

##### 4.2.1 Advancing Casing/Augers

Soil borings that are completed for soil sampling purposes are typically advanced using hollow-stem augers and sometimes drive-and-wash or other casing methods. The casing/augers must be of sufficient diameter to allow for soil sampling at a minimum. The casing/augers will be advanced according to project requirements to



the required depth for sampling. If hollow-stem augers are used, a temporary plug shall be used in the lead auger to prevent the auger from becoming filled with drill cuttings while drilling is in progress.

#### **4.2.2 Obstructions**

For those borings that encounter obstructions, the casing/augers will be advanced past or through the obstruction if possible. Caution should be exercised when obstructions are encountered and an effort made to identify the obstruction before drilling is continued. If the obstruction is not easily drilled through or removed, the boring should be relocated to an adjacent location.

#### **4.2.3 Use of Added Water**

The use of added or recirculated water during drilling is permitted when necessary. Use of extraneous water should be minimized or avoided if possible as it may impact sample quality. Water usage should be documented in the field logbook. Sampling and analysis of added or recirculated water may be required for quality assurance purposes (refer to QAPP). If a well is installed within the completed borehole, removal of the added water may be required.

### **4.3 Sampling Procedure**

#### **4.3.1 Equipment Decontamination**

Each split spoon must be decontaminated prior to its initial use and following collection of each soil sample. Site-specific requirements for equipment decontamination should be outlined within the Project Sampling Plan. Equipment decontamination procedures are also outlined within SOP 7600-04020 – Decontamination of Equipment.

#### **4.3.2 Standard Penetration Test**

The drilling subcontractor will lower the split spoon into the borehole. Samples are generally obtained using the Standard Penetration Test (SPT) in accordance with ASTM standards (ASTM D 1586-99). Following this method, the sampler will be driven using the 140-pound hammer with a vertical free drop of 30 inches. The number of hammer blows required for every 6 inches of penetration will be recorded on the boring log. Blowcount information is used as an indicator of soil density for geotechnical as well as stratigraphic logging purposes. Once the split spoon has been driven to its fullest extent, or to refusal, it will be removed from the borehole.

#### **4.3.3 Sample Recovery**

The split spoon will be immediately opened upon removal from the casing/auger. The open sampler shall then be screened for volatile organics with a photoionization device (PID) if required by the Project Sampling Plan. If the Sampling Plan also

requires individual soil sample headspace screening for volatile organic compounds, then a small portion of the split-spoon sample shall be removed and properly contained for that purpose.

Sample recovery will be determined by the project geologist/sampling engineer who will examine the soil core once the sampler is opened. The length of sample shall then be measured with a folding rule or tape measure. Any portion of the split spoon contents that are not considered part of the true sample (i.e., heaved soils) will be discarded. If the sample recovery is considered inadequate for sample characterization or analytical testing purposes, another sample should be collected from the next vertical interval if possible before drilling is reinitiated.

Adequate sample recovery for stratigraphic logging purposes and/or headspace organic vapor testing purposes should be approximately 6 inches. Adequate sample recovery for analytical testing purposes should be a minimum of 12 inches and is somewhat dependent on the type of analytical testing required. In some cases, continuous sampling over a short interval, and compositing of the sample, may be required to satisfy analytical testing requirements. Larger diameter samplers may be used if large volumes of soil are required for analytical testing.

#### **4.3.4 Sample Containment – General**

Once retrieved, the sample will be removed from the split spoon with a teaspoon or spatula and placed into the appropriate sample container. The sample will be split if necessary to meet sampling program requirements. Sample splitting may be necessary to provide individual samples for headspace testing, visual characterization, physical testing, analytical testing, or simply for archiving purposes. In general, most sampling programs are structured around environmental characterization needs; therefore, sample portions required for analytical testing should be collected first. The Project Sampling Plan and QAPP provide specific sample container requirements for each type of sample and should be referred to for guidance.

Once filled, the sample containers should be properly capped, cleaned, and labeled, and chain-of-custody and sample preservation procedures initiated. Sampling equipment should then be properly decontaminated.

#### **4.3.5 Sample Containment – Volatile Organic Analyses**

Collection of subsurface soil samples for volatile organic analysis (VOA) is slightly more complex than collection of samples for other routine chemical or physical testing primarily because of the concern for the potential loss of volatiles during the sample collection procedure. To limit the potential for loss of volatiles, the soil sample needs to be obtained as quickly and as directly as possible from the split spoon. This generally means that the VOA sample is to be collected and placed into the appropriate sample container first, leaving no headspace. The VOA sample

should also be obtained from a discrete portion of the entire sample interval and not composited or homogenized. The remainder of the recovered sample can then be composited, homogenized, or split to meet the other testing requirements. The boring log and/or sample logbook should be filled out to indicate actual sample collection depths for both VOA samples and other portions of the sample that may have been composited over a larger vertical interval. Procedures for collection of samples for VOA using U.S. Environmental Protection Agency (EPA) method 5035 are contained in a separate SOP.

## 5.0 QUALITY CONTROL

Quality control requirements are dependent on project-specific sampling objectives. The QAPP will provide requirements for sample preservation and holding times, sample container types, sample packaging and shipment, as well as requirements for the collection of various quality assurance samples such as trip blanks, field blanks, equipment blanks, and field duplicate samples.

## 6.0 DOCUMENTATION

Various forms are required to ensure that adequate documentation is made of sample collection activities. These forms include:

- Boring logs
- Field logbooks
- Sample collection records
- Chain-of-custody records
- Shipping labels

Boring logs (Figure 1) will provide visual and descriptive information for each sample collected and are often the most critical form of documentation generated during a sampling program. The field logbook is kept as a general log of activities. Chain-of-custody forms are transmitted with the samples to the laboratory for sample tracking purposes. Shipping labels are required if sample coolers are to be transported to the laboratory by a third party (courier service). Original copies of these records should be maintained in the appropriate project files.

## 7.0 REFERENCES

ASTM D 1586-99

SOP NUMBER: 7115-04020

Figure 1

|   |                    |                         |                          |                         |                            |                                   |   |                                     |                        |
|---|--------------------|-------------------------|--------------------------|-------------------------|----------------------------|-----------------------------------|---|-------------------------------------|------------------------|
|  |                    | <i>Client:</i>          |                          |                         |                            | <b>BORING ID:</b>                 |   |                                     |                        |
|   |                    | <i>Project Number:</i>  |                          |                         |                            |                                   |   |                                     |                        |
|   |                    | <i>Site Location:</i>   |                          |                         |                            | <i>Sheet: 1 of 1</i>              |   |                                     |                        |
|   |                    | <i>Coordinates:</i>     |                          | <i>Elevation:</i>       |                            |                                   |   |                                     |                        |
|   |                    | <i>Drilling Method:</i> |                          |                         |                            | <i>Monitoring Well Installed:</i> |   |                                     |                        |
| <i>Sample Type(s):</i>  |                    |                         |                          | <i>Boring Diameter:</i> |                            | <i>Screened Interval:</i>         |   |                                     |                        |
| <i>Weather:</i>   |                    |                         | <i>Logged By:</i>        |                         | <i>Date/Time Started:</i>  |                                   | <i>Depth of Boring:</i>   |                                     |                        |
| <i>Drilling Contractor:</i>   |                    |                         | <i>Ground Elevation:</i> |                         | <i>Date/Time Finished:</i> |                                   | <i>Water Level:</i>   |                                     |                        |
| Depth (ft)  | Geologic sample ID | Sample Depth (ft)       | Blows per 6"             | Recovery (inches)       | Headspace (ppm)            | U.S.C.S                           | <b>MATERIALS: Color, size, range, MAIN COMPONENT, minor component(s), moisture content, structure, angularity, maximum grain size, odor, and Geologic Unit (If Known)</b> | Lab Sample ID                       | Lab Sample Depth (ft.) |
| 1   |                    |                         |                          |                         |                            |                                   |   |                                     |                        |
| 2   |                    |                         |                          |                         |                            |                                   |   |                                     |                        |
| 3   |                    |                         |                          |                         |                            |                                   |   |                                     |                        |
| 4   |                    |                         |                          |                         |                            |                                   |   |                                     |                        |
| 5   |                    |                         |                          |                         |                            |                                   |   |                                     |                        |
| 6   |                    |                         |                          |                         |                            |                                   |   |                                     |                        |
| 7   |                    |                         |                          |                         |                            |                                   |   |                                     |                        |
| 8   |                    |                         |                          |                         |                            |                                   |   |                                     |                        |
| 9   |                    |                         |                          |                         |                            |                                   |   |                                     |                        |
| 10  |                    |                         |                          |                         |                            |                                   |   |                                     |                        |
| 11  |                    |                         |                          |                         |                            |                                   |   |                                     |                        |
| 12  |                    |                         |                          |                         |                            |                                   |   |                                     |                        |
| 13  |                    |                         |                          |                         |                            |                                   |   |                                     |                        |
| 14  |                    |                         |                          |                         |                            |                                   |   |                                     |                        |
| 15  |                    |                         |                          |                         |                            |                                   |   |                                     |                        |
| 16  |                    |                         |                          |                         |                            |                                   |   |                                     |                        |
| 17  |                    |                         |                          |                         |                            |                                   |   |                                     |                        |
| 18  |                    |                         |                          |                         |                            |                                   |   |                                     |                        |
| 19  |                    |                         |                          |                         |                            |                                   |   |                                     |                        |
| 20  |                    |                         |                          |                         |                            |                                   |   |                                     |                        |
| <b>NOTES:</b><br><br><br><br>Checked by _____ Date: _____                         |                    |                         |                          |                         |                            | Date                              | Time  | Depth to groundwater while drilling |                        |
|   |                    |                         |                          |                         |                            |                                   |   |                                     |                        |
|   |                    |                         |                          |                         |                            |                                   |   |                                     |                        |
|   |                    |                         |                          |                         |                            |                                   |   |                                     |                        |
|   |                    |                         |                          |                         |                            |                                   |   |                                     |                        |

**SOP NUMBER: 7116-04020**

**Subsurface Soil Sampling by Geoprobe™ Methods**

**Date:** September 22, 2006  
**Revision Number:** 1  
**Author:** Sally Bilodeau  
**Discipline:** Geosciences

**1.0 INTRODUCTION**

**1.1 Purpose and Applicability**

This Standard Operating Procedure (SOP) describes the methods available for collecting subsurface soil samples using commercially available Geoprobe™ Systems (or other similar vendor) soil probing equipment. Subsurface soil samples may be obtained using this system for purposes of determining subsurface soil conditions and for obtaining soil samples for physical and/or chemical evaluation.

The purpose of this SOP is to provide a description of a specific method or procedure to be used in the collection of subsurface soil samples using the Geoprobe™ system. Subsurface soil is defined as unconsolidated material that may consist of one or a mixture of the following materials: sand, gravel, silt, clay, peat (or other organic soils), and fill material. Subsurface soil sampling, conducted in accordance with this SOP, will promote consistency in sampling and provide a basis for sample representativeness.

This SOP covers subsurface soil sampling using Geoprobe™ Systems equipment; specifically, the Macro-Core Soil Sampler and the Large Bore Sampler. Use of this sampling equipment requires use of the Geoprobe™ hydraulically powered percussion/probing machine. Geoprobe™ sampling is usually performed by subcontractors, although rental equipment is available for use by trained operators.

The Geoprobe™ sampling methods covered in this SOP are applicable to unconsolidated soil/fill materials and to a maximum recommended depth of approximately 30 feet. Sampling depths are greatly dependent upon soil density as the hydraulically powered probing unit has power limitations. Sample recovery is also somewhat dependent on grain size as very coarse gravel, cobbles, and boulders will occasionally cause premature refusal of the sampler. It is generally preferable to have some prior knowledge of site soil conditions if sampling activities are proposed where equipment limitations may become a factor.

Other types of equipment and sampling methods are available for use in obtaining samples of unconsolidated materials and include split-spoons, Shelby tubes, and continuous core barrel samplers. Information on these and other soil sampling devices may be found in other ENSR SOPs, American Society for Testing and Materials (ASTM) procedures, drilling handbooks, and respective state and/or federal agency technical guidance documents.

## 1.2 General Principles

Soil sampling using the Geoprobe™ System requires use of the hydraulically powered percussion/probing machine and either the Macro-Core Soil Sampler or the Large Bore Sampler soil sampling devices. The percussion/probing machine is typically mounted onto the bed of a pickup truck or van so that a stable working platform is established. The percussion/probing machine, through its hydraulic operation, pushes and hammers the soil sampling equipment vertically into the ground within the targeted sampling interval. The soil sampler is then extracted from the ground to recover the sample.

The Macro-Core Sampler (Figure 1) consists of a 45-inch long by 1.5-inch diameter open-ended steel sampling tool with liners made of clear plastic (cellulose acetate butyrate), stainless steel, or Teflon. The tool is designed for use in a continuous sampling capacity in an open borehole up to depths of approximately 24 feet. The borehole walls are required to stay open in order to collect a sample from the next depth interval. Once the sampling tool is removed from the ground, the inserted liner containing the soil sample is removed from the tool. The soil sample is then cut from or extracted from the liner. This sampling tool is most often used for soil profiling and collection of larger volume soil samples (1,300 milliliters [ml]).

The Large Bore Sampler (Figure 2) consists of a 22-inch long by a slightly over 1-inch diameter steel sampling tool and may be used for sampling to depths of approximately 30 feet. Various liner types are available for use with this sampler and include plastic, brass, stainless steel, and Teflon. The metal liners are available in segmented 6-inch lengths. The sampler is designed for discrete interval sampling and is not affected significantly by borehole wall collapse. This sampler is similar to a piston sampler where a retractable drive (piston) point is withdrawn when the targeted sampling interval is achieved and the soil sample enters the sampler. Once the sampler is removed from the ground, the inserted liner containing the soil sample is extracted from the sampler and the soil sample is then cut from or extracted from the liner. The segmented liner materials and discrete interval sampling capability gives this device greater suitability for collection of smaller volume soil samples (320 ml).

## 1.3 Quality Assurance Planning Considerations

Sampling personnel should follow specific quality assurance guidelines as outlined in the site-specific Quality Assurance Project Plan (QAPP). Proper quality assurance requirements should be provided that will allow for collection of representative samples from representative sampling points. Quality assurance requirements outlined in the QAPP typically suggest the collection of a sufficient quantity of field duplicate, field blank, and other samples.

## 1.4 Health and Safety Considerations

The health and safety considerations for the site, including both potential physical and chemical hazards, will be addressed in the site-specific Health and Safety Plan (HASP). All field activities will be conducted in conformance to this HASP. This plan must be approved by the project Health and Safety Officer before work commences, must be distributed to all personnel performing sampling, and must be adhered to as field activities are performed.

## 2.0 RESPONSIBILITIES

### 2.1 Project Geologist/Sampling Engineer

It will be the responsibility of the project geologist/sampling engineer to conduct subsurface soil sampling in a manner consistent with this SOP. The project geologist/sampling engineer will observe all activities pertaining to subsurface soil sampling to ensure that the SOP is followed and to record all pertinent data onto a boring log. It is also the project geologist/sampling engineer's responsibility to indicate the specific targeted sampling depth or sampling interval to the drilling subcontractor. The project geologist/sampling engineer is also responsible for the collection of representative environmental or stratigraphic characterization samples once the sampling device has been retrieved and opened. Additional sample collection responsibilities include labeling, handling, and storage of samples until further chain-of-custody procedures are implemented.

### 2.2 Drilling Subcontractor

It will be the responsibility of the drilling subcontractor to provide the necessary Geoprobe™ equipment for obtaining subsurface soil samples. This generally includes the truck or ATV-mounted percussion/probing machine and one or more Macro-Core and Large Bore samplers in good operating condition, appropriate liners, and other necessary equipment for borehole preparation and sampling. It is the drilling subcontractor's responsibility to provide and maintain their own boring logs if desired. Equipment decontamination materials should also be provided by the subcontractor and should meet project specifications.

## 3.0 REQUIRED MATERIALS

In addition to those materials provided by the subcontractor, the project geologist/sampling engineer will require:

- Project Sampling Plan, QAPP, and HASP
- Boring Logs
- Teaspoon or spatula
- Sample kit (bottles, labels, custody records and tape, cooler)
- Sample collection pan
- Folding rule or tape measure
- Utility knife
- Equipment decontamination materials (as required by QAPP)
- Health and safety equipment (as required by HASP)
- Field project logbook/pen

Sampling equipment that comes in direct contact with environmental samples during the sample collection process should be constructed of stainless steel, Teflon, or glass, unless specified otherwise in the Project Sampling Plan or QAPP.

## 4.0 METHOD

### 4.1 General Method Description

Geoprobe™ soil sampling methods generally involve collection of soil samples by driving the sampling tool directly into the ground using the percussion/probing machine and without the aid of hollow-stem augers or other casing-installed drilling methods. Both the Macro-Core and Large Bore soil samplers consist of metal tubes of seamless construction that can not be split apart like split-spoons. Liner/sleeve inserts are required in order to extract an intact soil core/sample from the sampling device.

Both sampling devices operate by being directly pushed/hammered into the ground by the percussion/probing machine. The borehole is created as the sampling device is advanced downward. The Macro-Core Sampler collects samples continuously and requires that an open borehole be maintained for efficient sample recovery. The Large Bore Sampler contains a piston tip/drive point that allows for advancing the sampler to a designated depth for discrete interval sampling. The piston tip is retracted when the desired sampling interval is reached.

When the soil sampling device is retrieved from the borehole, the drive head, cutting shoe, and/or piston assembly is removed, and the liner insert with sample is removed from the sampling device. The project geologist/sampling engineer is then given access to the sample for whatever purpose is required.

Table 1 summarizes the construction characteristics and sampling attributes of each type of sampler. The appropriate type of sampler should be selected based on project-specific sampling requirements.

### 4.2 Equipment Decontamination

Each sampling device must be decontaminated prior to its initial use and following collection of each soil sample, especially if sampling for analytical testing purposes is conducted. If sampling for soil logging only is conducted, thorough sampler decontamination between samples may not be necessary, although sufficient cleansing is necessary for the sampler to operate properly. Site-specific requirements for equipment decontamination should be outlined in the Project Sampling Plan. Equipment decontamination procedures are also outlined within SOP 7600-04020 – Decontamination of Equipment.



### 4.3 Sampling Procedures – Macro-Core Sampler

(Note: These procedures are excerpted from Geoprobe™ Systems literature. This SOP assumes that the subcontractor will perform sampling; therefore, detailed procedures regarding sample acquisition are not provided.)

#### 4.3.1 Sampler Preparation

- Decontaminate the sampler parts (cutting shoe, sample tube, liners) before assembly.
- Assemble the sampler by first placing the liner over the inside end of the cutting shoe, then inserting the liner/shoe assembly into the sample tube, and then finally threading the cutting shoe into the sample tube. Tighten the cutting shoe with the shoe wrench.
- Thread the sampler onto the drive head.

#### 4.3.2 Sampling

- Using the percussion/probing machine, drive the sampler into the ground until the drive head reaches the ground surface.
- For deeper samples, the borehole walls must remain stable. The cutting shoe is designed with a tapered surface to limit sidewall scraping. Add additional probe rods until the sampler reaches the targeted sample interval, then drive the sampler through the desired sample interval.
- Use the machine hydraulics to pull the sampler from the borehole.

#### 4.3.3 Sample Recovery

- Once the sampler has been removed from the borehole, the sampler must be unthreaded from the drive head, the cutting shoe unthreaded from the sampler, and the liner/shoe assembly removed from the sample tube.
- Disconnect the cutting shoe from the liner that contains the soil sample. The recovered soil sample may now be viewed, logged, and extracted from the liner for analysis (refer to Section 4.5 for sample containment procedures).

### 4.4 Sampling Procedures – Large Bore Sampler

(Note: These procedures are excerpted from Geoprobe™ Systems literature. This SOP assumes that the subcontractor will perform sampling; therefore, detailed procedures regarding sample acquisition are not provided. Additional detailed sampling procedures for this specific item of equipment is presented in Geoprobe™ Technical Bulletin No. 93-660, available through Geoprobe™ manufactures.)

#### 4.4.1 Sampler Preparation

- Decontaminate the sampler parts (cutting shoe, piston rod/tip, sample tube, liners) before assembly.
- Assemble the sampler by first placing the liner on the cutting shoe, then threading the liner/shoe assembly into the sample tube, then connecting the piston tip to the piston rod, and then finally inserting the piston tip/rod assembly into the sample tube. Tighten the cutting shoe with the shoe wrench.
- Thread the sampler onto the drive head. Thread the stop-pin onto the drive head (stop-pin holds the piston tip/rod in place while driving the sampler to the desired sample interval).

#### 4.4.2 Sampling

- Using the percussion/probing machine, drive the sampler into the ground until the upper portion of the targeted sampling interval is achieved.
- Unthread and remove the stop-pin from the drive head using extension rods. This will activate the piston tip/rod.
- Drive the sampler through the targeted sampling interval to collect the sample. The piston tip/rod will retract as the sample enters the sample tube.
- Use the machine hydraulics to pull the sampler from the ground.

#### 4.4.3 Sample Recovery

- Once the sampler has been removed from the ground, the sampler must be unthreaded from the drive head, then the cutting shoe unthreaded from the sample tube, and the liner/shoe assembly removed from the sample tube.
- Disconnect the cutting shoe from the liner that contains the soil sample. The recovered soil sample may now be viewed, logged, and extracted from the liner for analysis (refer to Section 4.5 for sample containment procedures).

### 4.5 Sample Containment

#### 4.5.1 General

- The soil sample can be removed from the liner following viewing and/or logging. Non-segmented plastic or Teflon liners should be cut with a utility knife into approximate 6-inch lengths to facilitate sample extraction or to isolate specific sample zones targeted for analysis. Segmented metal liners can be manually separated.

- Once the liner has been separated, the soil sample may be extracted from the individual liner segments with a spoon or spatula. Except for volatile organic analysis (VOA) samples (see below), the soil sample should be placed into a sample collection pan and homogenized. Place the sample directly into the required sample container.
- Once filled, the sample container should be properly capped, cleaned, and labeled. Sample chain-of-custody and preservation procedures should then be initiated.
- Perform equipment decontamination following containment of the sample.

#### 4.5.2 Volatile Organic Samples

- Use of Teflon liners is preferred when sampling for analysis of volatile organic compounds (VOC) because these liners are more inert. In order to limit the potential for loss of volatiles, the soil sample should be removed from the liner as soon as possible after sample recovery. VOC soil samples should be selected from a central point within the liner unless another specific sample zone has been targeted. The liner should be cut with a knife and the sample immediately extracted and containerized. Clean and label the container and place it into a cooler immediately. Residual sample may then be used to fill other sample or logging requirements. Collecting samples for VOA using U.S. Environmental Protection Agency (EPA) method 5035 is addressed in a separate SOP.

## 5.0 QUALITY CONTROL

Quality control requirements are dependent on project-specific sampling objectives. The QAPP will provide requirements for equipment decontamination (frequency and materials), sample preservation and holding times, sample container types, sample packaging and shipment, as well as requirements for the collection of various quality assurance samples such as trip blanks, field blanks, equipment blanks, and field duplicate samples.

## 6.0 DOCUMENTATION

Various forms are required to ensure that adequate documentation is made of sample collection activities. These forms include:

- Boring logs
- Field logbooks
- Sample collection records
- Chain-of-custody records
- Shipping labels

Boring logs (Figure 3) will provide visual and descriptive information for each sample collected and are often the most critical form of documentation generated during a soil sampling program. The field

logbook is kept as a general log of activities and should not be used in place of the boring log. Occasionally, sample collection records are used to supplement boring logs, especially for environmental samples that have been collected for laboratory analysis. Chain-of-custody forms are transmitted with the samples to the laboratory for sample tracking purposes. Shipping labels are required if sample coolers are to be transported to the laboratory by a third party (courier service). Original copies of these records should be maintained in the appropriate project files.

## 7.0 REFERENCES

Geoprobe™ Systems, Equipment and Tools Catalog.

**TABLE 1**  
**Geoprobe Systems Soil Sampler Characteristics**

| Sampler Type | Length (in.) | Diameter (in.) | Volume (ml) | Sleeve Liner Type | Suitability <sup>1</sup> |                  |                     |                   |
|--------------|--------------|----------------|-------------|-------------------|--------------------------|------------------|---------------------|-------------------|
|              |              |                |             |                   | Soil Logging             | Physical Testing | Chemical-Inorganics | Chemical-Organics |
| Macro-Core   | 45           | 1.5            | 1,300       | Acetate           | A                        | A                | A                   | B                 |
|              |              |                |             | Stainless Steel   | B                        | A                | B                   | A                 |
|              |              |                |             | Teflon            | A                        | A                | A                   | A                 |
| Large Bore   | 22           | 1.06           | 320         | Acetate           | A                        | A                | A                   | B                 |
|              |              |                |             | Brass             | B                        | A                | B                   | B                 |
|              |              |                |             | Stainless Steel   | B                        | A                | B                   | A                 |
|              |              |                |             | Teflon            | A                        | A                | A                   | A                 |

<sup>1</sup> A - Preferred suitability  
B - Acceptable suitability

Figure 1 – Soil Sampling Tools – Macro-Core Sampler - Parts

## SOIL SAMPLING TOOLS - Macro-Core Sampler - Parts



### Macro-Core Sampler

#### AT-720 Series

The sampler features a nickel-plated sample tube that is 48" long x 2.0" in diameter, a hardened tool steel cutting shoe that has a 1.5" diameter opening, and a tapered drive head that fits standard Geoprobe probe rods. The overall length assembled is 51.25". Sample recovery is 45" long x 1.50" diameter (1302 ml) in a PETG liner.

| PARTS   | KITS  | LINERS   |
|---|---|--|
| <b>AT-720</b> MC Cutting Shoe<br><b>AT-721</b> MC Drive Head<br><b>AT-722</b> MC Sample Tube<br><b>AT-725</b> MC PETG (clear plastic) Liner<br><b>AT-726</b> MC Vinyl End Cap<br><b>AT-727</b> MC Shoe Wrench | <b>Assembled Macro-Core Sampler*</b><br><b>Part No. AT-720K</b><br>Includes the following parts:<br>(1) <b>AT-720</b> MC Cutting Shoe<br>(1) <b>AT-721</b> MC Drive Head<br>(1) <b>AT-722</b> MC Sample Tube<br>*kit does not include liners and end caps | <b>AT-725K</b> MC PETG Liners (pre-flared, clear plastic) Box of 66 only<br><b>AT-726K</b> MC Vinyl End Caps (fit AT-725 liners) Box of 66 pairs (66 red/66 black) |

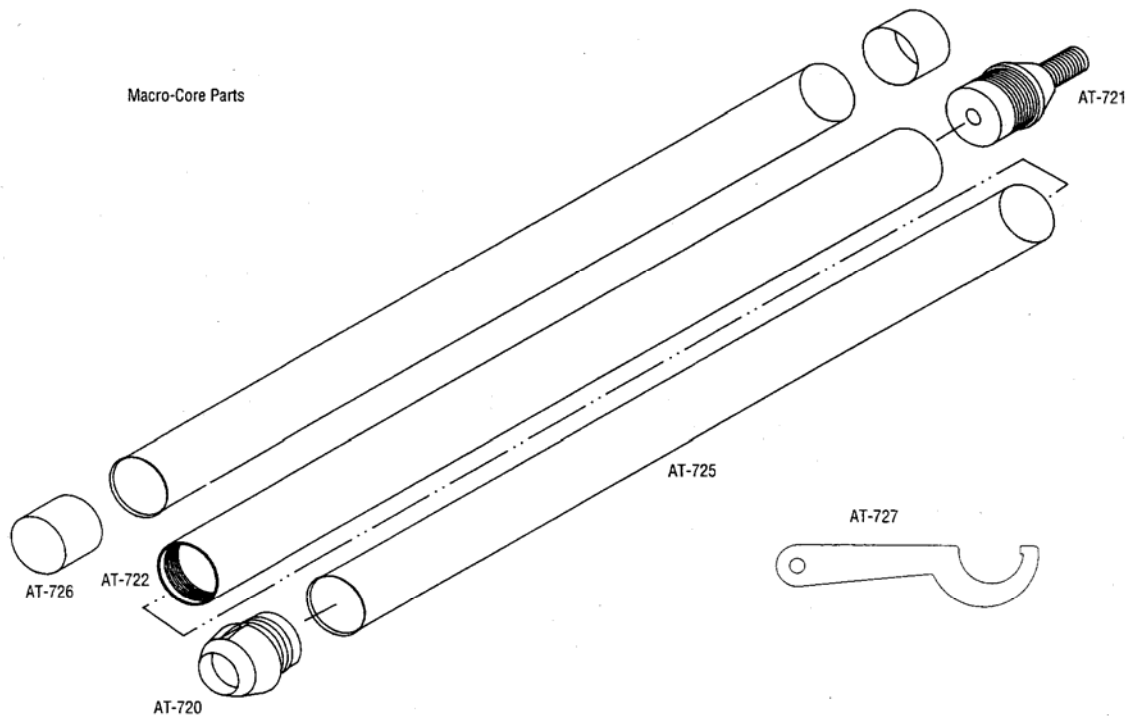

Figure 2 – Soil Sampling Tools – Probe Drive System/Large Bore

# SOIL SAMPLING TOOLS - Probe Drive System/Large Bore

## Large Bore Sampler

### AT-660 Series

Features nickel plated sample tube, replaceable hardened tool steel cutting shoe and removable liner. Recovers core approximately 22" long x 1-1/16" diameter (320 ml). Uses STD Piston Stop-Pin. Recommended for sampling depths up to 30 feet. Liners available in brass, stainless steel, PTFE (Teflon), or PETG (clear plastic).

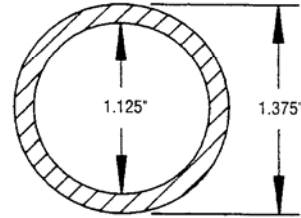

Actual size of sample tube

### Large Bore Sampler Parts:

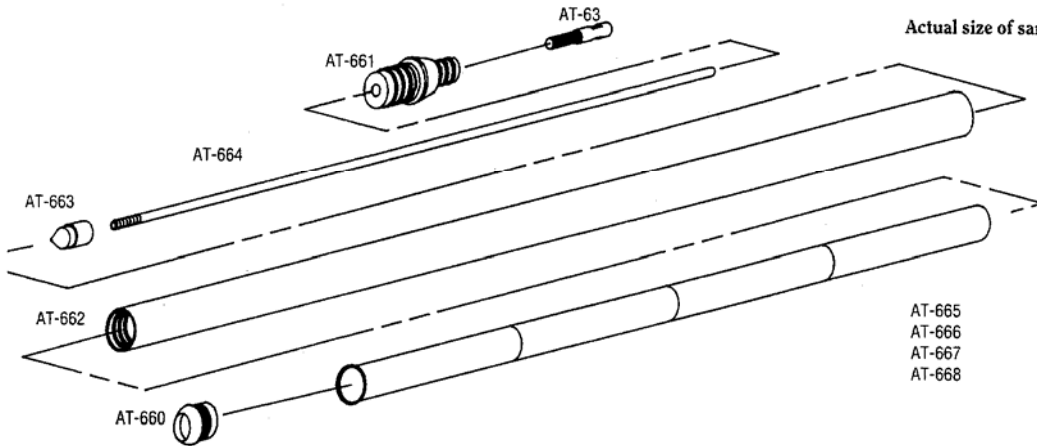

| PARTS                           |                           |                             |
|---------------------------------|---------------------------|-----------------------------|
| <b>Large Bore Sampler Parts</b> | <b>Liners</b>             | <b>Also required:</b>       |
| AT-660 LB Cutting Shoe          | AT-665 LB PETG Liner      | AT-63 STD Stop-Pin          |
| AT-661 LB Drive Head            | AT-666 LB Brass Liner     | AT-63R Stop-Pin O-rings     |
| AT-662 LB Sample Tube           | AT-667 LB Stainless Liner | AT-67 Extension Rod         |
| AT-663 LB Piston Tip            | AT-668 LB PTFE Liner      | AT-68 Extension Rod Coupler |
| AT-664 LB Piston Rod            |                           | AT-69 Extension Rod Handle  |
| AT-669 LB Shoe Wrench           |                           |                             |

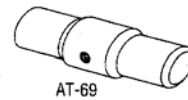

| PARTS   |                       |
|---|-----------------------|
| <b>Parts used with all Probe-Drive Samplers</b> |                       |
| AT-63   | STD Stop-Pin          |
| AT-63R  | Stop-Pin O-rings      |
| AT-67   | Extension Rod         |
| AT-68   | Extension Rod Coupler |
| AT-69   | Extension Rod Handle  |

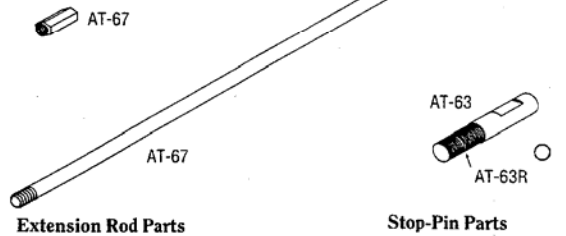

SOP NUMBER: 7116-04020

Figure 3 – Boring Log

|  |                    | <i>Client:</i>          |              |                          |                 | <b>BORING ID:</b>                 |  |               |                        |                                     |  |
|---|--------------------|-------------------------|--------------|--------------------------|-----------------|-----------------------------------|--|---------------|------------------------|-------------------------------------|--|
|   |                    | <i>Project Number:</i>  |              |                          |                 |                                   |  |               |                        |                                     |  |
|   |                    | <i>Site Location:</i>   |              |                          |                 | <i>Sheet: 1 of 1</i>              |  |               |                        |                                     |  |
|   |                    | <i>Coordinates:</i>     |              | <i>Elevation:</i>        |                 |                                   |  |               |                        |                                     |  |
|   |                    | <i>Drilling Method:</i> |              |                          |                 | <i>Monitoring Well Installed:</i> |  |               |                        |                                     |  |
|   |                    | <i>Sample Type(s):</i>  |              | <i>Boring Diameter:</i>  |                 | <i>Screened Interval:</i>         |  |               |                        |                                     |  |
| <i>Weather:</i>   |                    |                         |              | <i>Logged By:</i>        |                 | <i>Depth of Boring:</i>           |  |               |                        |                                     |  |
| <i>Drilling Contractor:</i>   |                    |                         |              | <i>Ground Elevation:</i> |                 | <i>Date/Time Finished:</i>        |  |               |                        |                                     |  |
| <i>Date/Time Started:</i>   |                    |                         |              | <i>Water Level:</i>      |                 |                                   |  |               |                        |                                     |  |
| Depth (ft)  | Geologic sample ID | Sample Depth (ft)       | Blows per 6" | Recovery (inches)        | Headspace (ppm) | U.S.C.S                           | MATERIALS: Color, size, range, MAIN COMPONENT, minor component(s), moisture content, structure, angularity, maximum grain size, odor, and Geologic Unit (If Known) | Lab Sample ID | Lab Sample Depth (ft.) |                                     |  |
| 1   |                    |                         |              |                          |                 |                                   |  |               |                        |                                     |  |
| 2   |                    |                         |              |                          |                 |                                   |  |               |                        |                                     |  |
| 3   |                    |                         |              |                          |                 |                                   |  |               |                        |                                     |  |
| 4   |                    |                         |              |                          |                 |                                   |  |               |                        |                                     |  |
| 5   |                    |                         |              |                          |                 |                                   |  |               |                        |                                     |  |
| 6   |                    |                         |              |                          |                 |                                   |  |               |                        |                                     |  |
| 7   |                    |                         |              |                          |                 |                                   |  |               |                        |                                     |  |
| 8   |                    |                         |              |                          |                 |                                   |  |               |                        |                                     |  |
| 9   |                    |                         |              |                          |                 |                                   |  |               |                        |                                     |  |
| 10  |                    |                         |              |                          |                 |                                   |  |               |                        |                                     |  |
| 11  |                    |                         |              |                          |                 |                                   |  |               |                        |                                     |  |
| 12  |                    |                         |              |                          |                 |                                   |  |               |                        |                                     |  |
| 13  |                    |                         |              |                          |                 |                                   |  |               |                        |                                     |  |
| 14  |                    |                         |              |                          |                 |                                   |  |               |                        |                                     |  |
| 15  |                    |                         |              |                          |                 |                                   |  |               |                        |                                     |  |
| 16  |                    |                         |              |                          |                 |                                   |  |               |                        |                                     |  |
| 17  |                    |                         |              |                          |                 |                                   |  |               |                        |                                     |  |
| 18  |                    |                         |              |                          |                 |                                   |  |               |                        |                                     |  |
| 19  |                    |                         |              |                          |                 |                                   |  |               |                        |                                     |  |
| 20  |                    |                         |              |                          |                 |                                   |  |               |                        |                                     |  |
| <b>NOTES:</b>   |                    |                         |              |                          |                 | Date                              |  | Time          |                        | Depth to groundwater while drilling |  |
|   |                    |                         |              |                          |                 |                                   |  |               |                        |                                     |  |
|   |                    |                         |              |                          |                 |                                   |  |               |                        |                                     |  |
|   |                    |                         |              |                          |                 |                                   |  |               |                        |                                     |  |
|   |                    |                         |              |                          |                 |                                   |  |               |                        |                                     |  |
|   |                    |                         |              |                          |                 |                                   |  |               |                        |                                     |  |
| Checked by _____  |                    |                         |              |                          |                 | Date: _____                       |  |               |                        |                                     |  |



**SOP NUMBER: 7124-04020**

**Field Measurement of Water Quality Parameters**

**Date:** September 22, 2006  
**Revision Number:** 1  
**Author:** Sally Bilodeau  
**Discipline:** Water

**1.0 INTRODUCTION**

**1.1 Purpose and Applicability**

This Standard Operating Procedure (SOP) provides basic instructions for routine calibration and operation of a variety of water quality meters, including the Hydrolab, Hydac Multimeter Probe, YSI Model 3500, Coastal Microqual, Horiba U-10, and Seabird 911 CTD.

**1.2 Quality Assurance Planning Considerations**

The end use of the data will determine the quality assurance requirements that are necessary to produce data of acceptable quality. These quality assurance requirements will be defined in the site-specific work plan and/or Quality Assurance Project Plan (QAPP), hereafter referred to as the project plan, or laboratory Quality Assurance Manual (QAM), and may include duplicate or replicate measurements or confirmatory analyses.

**1.3 Health and Safety Considerations**

The health and safety considerations for the laboratory or site, including both potential physical and chemical hazards, will be addressed in the site-specific Health and Safety Plan (HASP) or the laboratory QAM. Work will be conducted according to the ENSR and Tronox Health and Safety Policy and Procedures Manual and/or direction from the Tronox Site and/or Regional Health and Safety Manager.

**2.0 RESPONSIBILITIES**

**2.1 Analyst**

The analyst is responsible for verifying that the meter is in proper operating condition prior to use and for implementing the calibration and measurement procedures in accordance with this SOP, the project plan, and the manufacturers' instructions.

**2.2 Project Manager**

The project manager is responsible for ensuring that project-specific requirements are communicated to the project team and for providing the materials, resources, and guidance necessary to perform the measurements in accordance with this SOP and the project plan.

### 3.0 REQUIRED MATERIALS

The following materials are necessary for this procedure:

- Water quality meter
- Specific instrument manufacturer's instruction manual
- Deionized water
- Clean glass beakers or plastic cups
- Calibration solutions
- Calibration sheets
- Laboratory or field data sheets or logbooks
- Personal protective equipment (as required by HASP)

### 4.0 METHOD

#### 4.1 Sample Handling, Preservation, and General Measurement Procedures

- 4.1.1 Field measurements should be taken soon after sample collection since temperature changes, precipitation reactions, and absorption of carbon from the air can affect the measurements.
- 4.1.2 Report results as specified on the data sheet.
- 4.1.3 Calibration solutions and standards should not be used after their expiration dates as provided by the manufacturer. If the manufacturer does not supply an expiration date or if the standards are prepared from various salts (e.g., KCl), an expiration date of one year from purchase or preparation should be used. All standards must be labeled with manufacturer, lot number, and expiration date.

#### 4.2 Calibration and Measurement Procedures

- 4.2.1 The meter must be calibrated daily (or the calibration checked) before any analyses are performed. However, certain oceanographic instruments are calibrated only by the manufacturer (at their specified frequency) because of their sensitivity, such as the Seabird 911 CTD and the Coastal Microqual.
- 4.2.2 Set up the instrument according to the manufacturer's instructions.
- 4.2.3 Rinse the probe with deionized water.
- 4.2.4 Repeat the above procedure for the beakers or cups.
- 4.2.5 Follow the manufacturer's instructions for calibration.
- 4.2.6 Record the results of calibration on the calibration sheet.

**4.2.7** The meter must be recalibrated following any maintenance activities and prior to the next use.

## **5.0 QUALITY CONTROL**

- 5.1** The meter must be calibrated daily before use and recalibrated every 12 hours, and will not be used for sample determinations unless the initial check standard value is within 5% of the true value.
- 5.2** Oceanographic instruments will be calibrated every 6 months in the manufacturer's laboratory.
- 5.3** Duplicate measurements of a single sample may be performed at the frequency specified in the project plan. In the absence of project-specific criteria, duplicate measurements should agree within 10%.
- 5.4** Some agencies may require the analysis of U.S. Environmental Protection Agency (EPA) Water Pollution (WP) performance evaluation (PE) samples. These PE samples will be analyzed as required.

## **6.0 DOCUMENTATION**

- 6.1** The meter calibration, temperature check, and maintenance information will be recorded on the daily calibration sheet. (An example is presented as Figure 1). The data may be recorded on the appropriate laboratory or field data sheets or logbooks.
- 6.2** Calibration documentation must be maintained in a thorough and consistent manner. At a minimum, the following information must be recorded:
- Date and time of calibration
  - Signature or initials of person performing the calibration
  - Instrument identification number/model
  - Reading for standard before and after meter adjustment
- 6.3** Documentation for recorded data must include a minimum of the following:
- Date and time of analysis
  - Signature or initials of person performing the measurement
  - Instrument identification number/model
  - Sample identification/location

## **7.0 TRAINING/QUALIFICATIONS**

To properly perform measurements, the analyst must be familiar with the calibration and measurement techniques stated in this SOP. The analyst must also be experienced in the operation of the meter.

## 8.0 REFERENCES

American Public Health Association – American Water Works Association – Water Pollution Control Federation (APHA-AWWA-WPCF). Standard Methods for the Examination of Water and Wastewater, 17th Edition. 1989.

U.S. Environmental Protection Agency. Methods for the Chemical Analysis of Water and Wastes, (EPA 600/4-79-020). Revised 1983.



**SOP NUMBER: 7130-04020**

**Groundwater Sample Collection from Monitoring Wells**

**Date:** September 22, 2006  
**Revision Number:** 3  
**Author:** Sally Bilodeau  
**Discipline:** Geosciences

**1.0 PURPOSE AND APPLICABILITY**

**1.1 Purpose and Applicability**

This standard operating procedure (SOP) is concerned with the collection of valid and representative samples of groundwater from monitoring wells. The scope of this document is limited to field operations and protocols applicable during groundwater sample collection.

This SOP is written in a broad-based manner and considers the application of a variety of sampling equipment in the collection of representative groundwater samples. Respective state and/or federal agency regulations may require specific types of equipment to be used when applying this SOP to a particular project. The project manager should review the applicable regulatory requirements, if any, prior to the start of the field sampling program. Deviations from this SOP to accommodate regulatory requirements should be reviewed in advance of the field program and documented in the project work plan.

**1.2 Quality Assurance Planning Considerations**

Sampling personnel should follow specific quality assurance guidelines as outlined in the site-specific Quality Assurance Project Plan (QAPP). Proper quality assurance requirements should be provided that will allow for collection of representative samples from representative sampling points. Quality assurance requirements typically suggest the collection of a sufficient quantity of quality control (QC) samples such as field duplicate, equipment and/or field blanks, and matrix spike/matrix spike duplicate (MS/MSD) samples. These requirements should be outlined in the QAPP. Additional information regarding quality assurance sample collection relevant to groundwater sampling is contained in Section 5.0 of this SOP.

**1.3 Health and Safety Considerations**

Groundwater sampling may involve chemical hazards associated with the materials being sampled. Adequate health and safety measures must be taken to protect project sampling personnel from potential chemical exposures or other hazards. These measures must be addressed in the project Health and Safety Plan (HASP). This plan must be approved by the project Health and Safety Officer before work commences, must be distributed to all personnel performing sampling, and must be adhered to as field activities are performed.

## 2.0 RESPONSIBILITIES

### 2.1 Project Manager

The project manager is responsible for ensuring that project-specific requirements are communicated to the project team and for providing the materials, resources, and guidance necessary to perform the measurements in accordance with this SOP and the project-specific work plan.

### 2.2 Sampling Technician

It is the responsibility of the sampling technician to be familiar with the sampling procedures outlined within this SOP and with specific sampling, quality assurance, and health and safety requirements outlined within project-specific work plans (Sampling and Analysis Plan [SAP], HASP, QAPP). The sampling technician is responsible for collection of groundwater samples and for proper documentation of sampling activities as samples are being collected.

## 3.0 REQUIRED MATERIALS

Groundwater sampling objectives may vary significantly between projects. Project objectives should be defined within the project-specific work plans. The list of required materials below identifies the types of equipment that may be used for a range of groundwater sampling applications. From this list, a project-specific equipment list should be selected based upon project objectives and other factors such as the depth to groundwater, well construction, required purge volumes, and analytical parameters, among others. The various types of sampling equipment that may be used include:

### Well Purging Equipment

- Bailers
- Bladder pumps
- Submersible pumps
- Peristaltic pumps
- Centrifugal Pumps
- Waterra™ pumps

### Field Instruments

- Individual or multi-parameter meter(s) to measure temperature, pH, specific conductance, dissolved oxygen (DO), oxidation reduction potential (ORP), and/or turbidity
- Water level measuring device
- Interface probe or product detection paste

Sampling Equipment

- Reusable or disposable bailers
- Peristaltic pump
- Bladder pump

Sample Preparation Equipment

- Filtration equipment
- Intermediate containers
- Sample kit (i.e., bottles, labels, preservatives, custody records, cooler)

General Equipment

- Project-specific sampling plans (SAP, QAPP, HASP)
- Sample collection records
- Field logbook/pen
- Waterproof marker pens
- Deionized water dispenser bottler
- Sample cup
- Buckets
- Coolers or sample shuttles
- Instrument calibration solutions
- Power source (generator or 12V marine battery)
- Equipment decontamination supplies (refer to SOP 7600-04020)
- Health and safety supplies and personal protective equipment (as required by the HASP)
- First-Aid kit
- Tool box

Expendable Materials

- Deionized water supply
- Disposable bailer string (nylon or polypropylene)
- 0.45-micron filters
- Paper towels
- Plastic sheeting
- Ice/blue ice for sample preservation



- Disposable latex powder-free glove liners
- Disposable nitrile gloves
- Plastic trash bags
- Ziploc® bags

This equipment list was developed to aid in field organization and should be used in preparation for each sampling event. Depending on the site-specific sampling plan, additional material and equipment may be necessary and should be determined before the scheduled sampling event. Similarly, not all of the items shown in this list may be necessary for any one sampling event.

Additional SOPs are also available that provide procedures for different aspects of groundwater sampling. These SOPs include:

- ENSR SOP 7124-04020, Field Measurement of Water Quality Parameters (temperature, pH, EC, DO, and turbidity)
- ENSR SOP 7131-04020, Field Filtration of Water Samples for Inorganics
- ENSR SOP 7510-04020, Packaging and Shipment of Environmental Samples
- ENSR SOP 7600-04020, Decontamination of Field Equipment

## **4.0 METHOD**

### **4.1 Instrument Calibration**

Field instruments will be calibrated according to the requirements of the project-specific plan and water quality SOPs (see Section 3.0).

### **4.2 Sampling Preparation**

Prior to opening the well, the required personal protective equipment (as specified in the HASP) shall be donned. This, at a minimum, usually means wearing gloves to limit the potential for exposure to contaminants as well as reduce the potential for handling-induced contamination of sampling equipment.

### **4.3 Well Security and Condition**

At each monitoring well location, observe the conditions of the well and surrounding area. The following information shall be noted on the Groundwater Sample Collection Record (Attachment 1 or 2) or in the field logbook:

- Condition of the wells identification marker;
- Condition of the well lock and associated locking cap;

- Integrity of the well – protective outer casing, obstructions or kinks in the well casing, presence of water in the annular space, and the top of the interior casing; and
- Condition of the general area surrounding the well.

#### **4.4 Measuring Point Determination**

Before collecting a water level measurement, check for an existing measuring point (notch or other visible mark) established either at the time of well installation or by the latest survey. Generally, the measuring point is referenced from the top of the well casing (TOC), not the protective casing. If no measuring point exists, a measuring point should be established, clearly marked, and identified on the Groundwater Sample Collection Record or the field logbook. The same measuring point should be used for subsequent sampling events.

#### **4.5 Free Product Determination**

Wells that may potentially contain free product should be assessed for product with an interface probe or product detection paste. Interface probes generally operate on the same principle as a water level tape although they are designed to register water and product levels usually with different audible tones. Product paste generally is used in combination with some type of measuring tape that is lowered into the well with a coating of paste applied to it. Wells containing free product are generally not used for groundwater sampling, since the concentration of contaminants present in the free product can adversely effect the quality of the water sample, lending to a non-representative water sample.

#### **4.6 Water Level Measurement**

To obtain a water level measurement, lower the probe of a water level measuring device into the well until the audible sound of the unit is detected or the light on an electronic sounder illuminates. At this time the precise measurement should be determined (to nearest 0.01 feet) by repeatedly raising and lowering the tape to converge on the exact measurement. Obtain the reading of the TOC measuring point. The water level measurement should be entered on the Groundwater Sample Collection Record or in the field records.

The measurement device shall be decontaminated immediately after use with a non-phosphate detergent and rinsed with distilled water. Generally, only that portion of the tape that enters the water table should be cleaned. It is important that the measuring tape is never placed directly on the ground surface or allowed to become kinked. Measuring devices, including interface probes, that come into contact with free product will require more thorough decontamination (see SOP 7600-04020).

#### **4.7 Purge Volume Calculation**

Wells designated for sampling require purging to remove stagnant water in the well. A single casing or borehole (depending on local requirements) volume of groundwater will be calculated after measuring the length of the water column and checking the well casing diameter. The Groundwater Sample Collection Record provides information used to compute

the casing volume, which includes: a diagram, a numerical conversion table, and the standard calculation. The volume of standing water in the well (i.e., one purge volume) should be entered on the Groundwater Sample Collection Record.

## 4.8 Well Purging Methods and Procedures

### 4.8.1 Objectives

Prior to sample collection, purging must be performed for all groundwater monitoring wells to remove stagnant water from within the casing and gravel pack and to ensure that a representative groundwater sample is obtained.

There are three general types of non-dedicated equipment used for well purging: bailers, surface pumps, and down-well pumps. The purge method and equipment selected should be specified in the project-specific work plans.

**NOTE:** This SOP only describes the most common equipment and methods used for purging. Other purging equipment, as well as dedicated equipment, can be used provided that the method employed does not have an adverse affect on the overall quality of the groundwater.

Regardless of the purge method, purge water temperature, pH, and specific conductance will be monitored at predetermined purge volumes and recorded on the Groundwater Sample Collection Record. Additional water quality parameters may be required by the project-specific sampling plan. In general, purging will be considered complete following the withdrawal of at least 3 borehole volumes of groundwater and when the water quality parameters have stabilized over three consecutive readings as follows: the pH is within 0.1 unit, temperature is within 1 degree Celsius, electrical conductivity (EC) is within 3 percent, and the DO is within 5 percent. In general turbidity should be less than 10 nephelometric turbidity units (NTUs); however, if it is greater than 10 NTUs, the last three readings should be within 10 percent. If the water quality parameters do not stabilize, the sample may be collected but the lack of stabilization should be noted. If low flow (micropurge) pumping methods are being used, purging three borehole volumes is not required.

Purging a well to dryness may occur under some low-yield conditions. When the well recovers, a cascading effect may occur within the screened zone, which can volatilize some organic compounds. This may be considered inappropriate by regulatory agencies when volatile organic compounds (VOC) are the target analyte of interest. Purging a well to dryness then sampling after it has recovered may be acceptable for other target analytes, however. Under low yield conditions, low-flow sampling pumps such as bladder pumps may be required for VOC sample collection.

## 4.8.2 Bailing

### General

Bailing is often the most convenient method for well purging, especially if only a small volume of purge water is required during the purge routine. Bailers are constructed using a variety of materials including polyvinyl chloride (PVC), polyethylene, stainless steel, and Teflon. Teflon bailers are generally most "inert" and are available in reusable and disposable form. Disposable polyethylene bailers are relatively inert and inexpensive. Reusable stainless steel and PVC bailers must be decontaminated between uses. Most commercially available bailers are constructed to fit into a 2-inch diameter well, although other bailer diameters are available.

Waterra™ foot valves are essentially bailer check valves that manually thread onto the bottom of standard pump tubing (polyethylene, Teflon). The foot valves are commercially available in a variety of diameters in stainless steel, Teflon, and high-density plastic (Delrin). The foot valves operate by manually or mechanically raising and lowering the valve assembly within the water column, which raises the water level within the discharge tube. Flow rates usually in the vicinity of 1 gallon per minute (gpm) can be achieved with these devices.

Measurements of the pumping rate, temperature, pH, and specific conductance (and/or other parameters as required) should be made after each purge volume is removed and documented on the Groundwater Sample Collection Record or in the field logbook. Samples may be collected after the required purge volume has been withdrawn and the field parameters have stabilized to within the limits specified in Section 4.8.1 (pH is within 0.1 unit, temperature is within 1 degree Celsius, EC is within 3 percent, DO is within 5 percent, and turbidity is within 10 percent). Project-specific sampling objectives may require that the sample be collected with a bailer.

Bailing presents two potential problems with well purging. First, increased suspended solids may be present in samples as a result of the turbulence caused by raising and lowering the bailer through the water column. High solids concentrations may affect sample representativeness. Second, bailing may be less feasible for deep wells or wells that require a large volume of water to be removed during purging because of the time involved with continuous insertion and removal/emptying of the bailer.

### Bailing Procedure

Obtain a clean bailer and a spool of clean polypropylene or nylon bailer cord. Uncover the top end of the bailer and tie a bowline knot, or equivalent, through the bailer loop. Test the knot and the bailer itself to ensure that all knots and parts are secure prior to inserting the bailer into the well.

Remove the protective wrapping from the bailer, and lower the bailer to the bottom of the monitoring well and cut the cord at a proper length. Bailer rope should never touch the ground surface at any time during the purge routine. Tie a hand loop at the end of the bailer cord.

Raise the bailer by grasping a section of cord using each hand alternately in a "rocking" action. This method requires that the sampler's hands be kept approximately 2 to 3 feet apart and that the bailer rope is alternately looped onto or off each hand as the bailer is raised and lowered.

Grab the bailer with one hand as it emerges from the well. Pour the bailed groundwater from the bailer into a graduated bucket to measure the purged water volume. Repeat this procedure until one complete purge volume of water is removed from the well.

At the end of one complete well purge volume, place a small amount of purged water into a sample cup. Measure temperature, pH, and specific conductance (and other assigned parameters) and record the results on the Groundwater Sample Collection Record or in the field logbook. Samples may be collected after the required purge volume has been withdrawn and the specific field parameters have stabilized to the limits specified in Section 4.8.1 (pH is within 0.1 unit, temperature is within 1 degree Celsius, EC is within 3 percent, DO is within 5 percent, and turbidity is within 10 percent).

### 4.8.3 Surface Pumps

#### General

Well purging using pumps located at the ground surface can be performed with peristaltic or centrifugal pumps if the water level in the well is within approximately 20 feet of the top of the well.

Peristaltic pumps provide a low rate of flow typically in the range of 0.02 to 0.2 gpm (75 to 750 milliliters per minute). For this reason, peristaltic pumps are not particularly effective for well purging. Peristaltic pumps are suitable for purging situations where disturbance of the water column must be kept to a minimum for particularly sensitive analyses.

Centrifugal pumps are designed to provide a high rate of pumping, in the range of 5 to 40 gpm, depending on pump capacity. Discharge rates can also be regulated somewhat, provided the pump has an adjustable throttle. These pumps also require polyethylene or Teflon-lined polyethylene tubing as suction line. The pump may also require priming to initiate flow.

### Peristaltic Pump Procedure

Attach a new suction and discharge line to the peristaltic pump. Silicon tubing must be used through the pump head and must meet the pump head specifications. A second type of tubing may be attached to the silicon tubing for use as the suction and discharge lines. The secondary tubing material, usually consisting of polyethylene or Teflon-lined polyethylene, should be compatible with the target analytes. The suction line must be long enough to extend to the static groundwater surface and reach further should drawdown occur during pumping.

Measure the length of the suction line and lower it down the monitoring well until the end is in the upper foot or more of the water column. Start the pump and direct the discharge into a graduated bucket. Adjust the pumping rate with the speed control knob so that a smooth flowing discharge is attained.

Measure the pumping rate in gallons per minute by recording the time required to fill a calibrated bucket. The pumping shall be monitored to assure continuous discharge. If drawdown causes the discharge to stop, lower the suction line very slowly further down into the well until pumping restarts.

Measurements of temperature, pH, and specific conductance (and/or other assigned parameters) should be made after each well purge volume and documented on the Groundwater Sample Collection Record or in the field logbook. Samples may be collected after the required purge volume has been removed and the specific field parameters have stabilized to within the limits specified in Section 4.8.1 (pH is within 0.1 unit, temperature is within 1 degree Celsius, EC is within 3 percent, DO is within 5 percent, and turbidity is within 10 percent). Project-specific sampling objectives may require that the sample be collected with a bailer.

### Centrifugal Pump Procedure

Attach a new suction and discharge line to the centrifugal pump. Start the pump and record the stabilized rate of discharge. As with other well purging systems, measurement of temperature, pH, and specific conductance (or other parameters as required) will be made after each well purge volume has been removed. These measurements shall be recorded on the Groundwater Sample Collection Record or in the field logbook. Samples may be collected after the required purge volume has been removed and the field parameters have stabilized to within the limits specified in Section 4.8.1 (pH is within 0.1 unit, temperature is within 1 degree Celsius, EC is within 3 percent, DO is within 5 percent, and turbidity is within 10 percent). Project-specific sampling objectives may require that the sample be collected with a bailer.

#### 4.8.4 Down-Well Pumps

##### General

Groundwater withdrawal using non-dedicated down-well pumps may be performed with a submersible pump or a bladder pump.

Electric submersible pumps provide an effective means for well purging and in some cases sample collection. Submersible pumps are particularly useful for situations where the depth to water table is greater than 20 feet and where the depth or diameter of the well requires that a large purge volume be removed before sample collection.

Commonly available submersible pumps include the Johnson-Keck pump model SP-82, the Grundfos Ready-Flow 2 pump, and disposable marine galley pumps, all of which are suited for operation in 2-inch or larger internal diameter wells.

The use of low flow bladder pumps (positive gas-displacement pumps) has been promoted by the U.S. Environmental Protection Agency (EPA) for use in well purging and sampling primarily because the pumps can be operated at low flow rates (less than 1 liter per minute). Bladder pumps generally reduce the potential turbidity of the sample and theoretically reduce the potential for loss of VOC constituents, ultimately providing a more representative groundwater sample. Use of bladder pumps may require additional time for purging and sampling because of the low flow rate. When using bladder pumps, it is not necessary to purge an entire well volume of water prior to recording the water quality parameters. Well purging is accomplished at such a low rate that, theoretically, the influent flow into the pump represents groundwater flow through the well screen, thereby eliminating the requirement for purging several entire well volumes of water before sample collection. Only the stagnant water in the water line needs to be evacuated prior to taking water quality field readings.

Bladder pumps usually consist of a stainless steel pump housing with an internal Teflon or polyethylene bladder. Discharge tubing is generally made from Teflon, polyethylene, or Teflon-lined polyethylene. The pump is operated by lowering it into the water column within the well screen, then pulsing air into the bladder with an air compressor and pump controller unit. Pumps and controllers are often not interchangeable between manufacturers, therefore, it is usually necessary to have both items provided by the same manufacturer. Pump bladders are generally field-serviceable and replaceable.

A check of well condition may be required prior to inserting any down-well pump if the well has not been sampled for some time or if groundwater quality conditions are not known. The well condition check should include a check of casing plumbness, as a bent well casing could cause a pump to get stuck. Casing plumbness can be checked by lowering a clean cylindrical tube with the approximate pump dimensions

into the well. If the well casing is not plumb, then an alternative purging method should be used.

The well inspection should also include a check of air quality or headspace conditions within the well for potentially explosive gasses and a check for free product that could foul the pump. Well casing headspace conditions can be monitored with a photoionization detector (PID) and/or an explosimeter for the presence of potentially explosive gasses. If potentially hazardous conditions exist, then an alternative purging method should be used. In general, it is rare for explosive conditions to be present.

The presence of free product should be determined before inserting the submersible pump into the well because free product may contaminate the pump's internal mechanisms, making it extremely difficult to decontaminate. An interface probe should be used to check for free product. Refer to Section 4.5 of this SOP for additional information on free product determination.

#### Electric Submersible Pump Procedure

Once the above well conditions have been assessed, and assuming it is safe to proceed, slowly lower the submersible pump with attached discharge line into the monitoring well taking notice of any roughness or restriction within the well riser pipe. The pump should be placed in the uppermost section of the static water column of the monitoring well. The power cord should be attached to the discharge line with an inert material (e.g., zip-ties) to prevent the power cord from getting stuck between the pump, discharge line, and the well casing. Secure the discharge line and power cord to the well casing, using tape or a clamp, taking care not to crimp or cut either the discharge line or power cord.

Connect the power cord to the power source (e.g., rechargeable battery pack, auto battery, or generator) and turn the pump on. Voltage and amperage meter readings on the pump controller (if provided) should be monitored closely during purging. The operations manual for the specific pump used should be reviewed regarding changes in voltage/amperage and the potential impacts on pump integrity. Pumping should be discontinued if warning conditions occur and/or if the well is pumped to where drawdown falls below the pump's intake level.

If drawdown continues to the extent that the well is pumped dry, the pump should be shut off and the well allowed to recharge. This on/off cycle may be necessary in order to purge the well properly.

Measurements of the pumping rate, temperature, pH, and specific conductance (and/or other required parameters) should be made after each purge volume is removed and documented on the Groundwater Sample Collection Record or in the field logbook. Samples may be collected after the required purge volume has been withdrawn and the field parameters have stabilized to within the limits specified in



Section 4.8.1 (pH is within 0.1 unit, temperature is within 1 degree Celsius, EC is within 3 percent, DO is within 5 percent, and turbidity is within 10 percent). Project-specific sampling objectives may require that the sample be collected with a bailer.

#### Bladder Pump Procedure

To operate the bladder pump system, the pump and discharge line should be lowered into the well within the lower portion of the screened interval, then secured to the well casing with a clamp. The air compressor should then be turned on to activate pumping. The pump controller is used to vary the discharge rate to the required flow. Care must be taken to minimize drawdown during pumping. Drawdown should not exceed 0.33 feet (0.1 meter). During purging, water levels are recorded at least once per minute, and water quality indicator parameters are recorded every 3 to 5 minutes.

Measurements of the pumping rate, temperature, pH, and specific conductance (and/or other required parameters) should be made at periodic intervals while water is removed and documented on the Groundwater Sample Collection Record or in the field logbook. Samples may be collected after the required field parameters have stabilized to within the limits specified in Section 4.8.1 (pH is within 0.1 unit, temperature is within 1 degree Celsius, EC is within 3 percent, DO is within 5 percent, and turbidity is within 10 percent). Generally, because of the low flow rate, samples are usually obtained from the bladder pump discharge line.

## **4.9 Sample Collection Methods and Procedures**

### **4.9.1 Objectives**

Groundwater samples can be collected using similar methods employed for purging, provided these methods do not adversely affect the quality of the groundwater. These methods include bailing, surface pumping, and down-well pumping.

In most cases during sampling, groundwater will be transferred to the appropriate containers directly for the discharge source. During transfer, discharge tubing and other equipment shall not contact the inside of the sample containers. In addition, a clean pair of nitrile or latex gloves will be worn during sample collection and handling.

As a general rule of thumb, samples should be collected in order of decreasing volatilization of the target parameters. The preferred order of sample collection is as follows: VOCs, extractable organic compounds (e.g., semivolatile organic compounds, polychlorinated biphenyls [PCBs], pesticides), metals, and general water chemistry (ions and turbidity).

#### 4.9.2 Bailers

The methods and procedures described in Section 4.8.2 also apply to collecting groundwater samples with a bailer. If a bailer was used to purge the well, the same bailer may be used for sampling. If other well purging equipment was used, a decontaminated or new disposable bailer should be used for sampling.

When VOCs are the target sampling parameter, a bottom discharge tip should be used during sample transfer. A discharge tip restricts the outflow of the sample from the bailer and diminishes the potential for volatilization. Reusable bailers may require a special screw-on tip fitted with a bottom discharge top. Disposable bottom discharge tips are usually supplied with disposable bailers.

Bailer cord shall be discarded after sampling is completed. Disposable bailers should only be used in one well. Reusable bailers should be appropriately decontaminated between uses.

#### 4.9.3 Surface Pumps

The methods and procedures described in Section 4.8.3 for peristaltic and centrifugal pumps also apply to groundwater sample collection.

##### Peristaltic Pumps

Peristaltic pumps equipped with the appropriate type tubing will be used to collect groundwater from wells in which the water resides at a depth less than 20 feet. Sample bottles shall be filled directly from the pump's discharge line and care shall be taken to keep the discharge tube from contacting the sample container.

Groundwater samples requiring filtration prior to placement in sample containers can be placed in intermediate containers for subsequent filtration or may be filtered directly with in-line disposable 0.45-micron filters, as described in SOP 7131-04020.

After sampling is complete, all used tubing and filters shall be disposed of appropriately.

##### Centrifugal Pumps

Centrifugal pumps are generally not recommended for use in sample collection, especially when VOCs are the target analyte of interest. Samples for other analytes, however, may be obtained with use of an in-line sample trap. It is suggested that if samples cannot be obtained before going through the pump, that samples be obtained by using a bailer once purging is complete and pumping has ceased. Collecting samples from the pump discharge is not recommended.

After sampling is complete, all suction line tubing should be disposed of properly.

#### 4.9.4 Down-Well Pumps

##### Electric Submersible Pump

Using the pump methods described in Section 4.8.4, groundwater samples can be collected directly from the pump discharge line, provided the discharge line is composed of inert material. Sample bottles will be filled directly from the discharge line of the pump. This method is generally not recommended for collection of volatile organic samples.

After sampling is complete, the pump, discharge line, and power cord shall be decontaminated according to the procedures contained in SOP 7600-04020 and/or disposed of as required by the project-specific work plan.

##### Bladder Pumps

Groundwater samples, including those collected for VOC analysis, may be collected directly from the pump discharge tubing under active pumping conditions. Sample bottles will be filled directly from the discharge line of the pump.

After sampling is complete, the pump, discharge line, and power cord shall be decontaminated according to the procedures outlined in SOP 7600-04020 and/or disposed of as required by the project-specific work plan.

#### 4.10 Sample Filtration

If filtration is required, the filtration of groundwater samples will be performed in accordance with SOP 7131-04020, only when approved by the client and/or a regulatory agency. Groundwater samples collected for total dissolved metals analyses will be filtered prior to being placed in sample containers and properly preserved. Groundwater filtration will be performed using a peristaltic pump and a 0.45-micron in-line water filter. Disposable filters are commonly available in 0.45-micron size. Low-capacity or high-capacity cartridges are available and may be selectively used based on sample turbidity.

The filtration of groundwater samples shall be performed either directly from the pump discharge line or from laboratory-supplied intermediate containers. In either case, well purging shall be performed first. Fresh groundwater shall then be filtered directly into sample containers.

#### 4.11 Sample Handling

All samples collected should be packaged and handled according to SOP 7510-04020 and the project-specific sampling plan. Preservatives should be used where analytical methods require preservation. The QAPP will indicate the type of sample preservation necessary.

## 5.0 QUALITY CONTROL

### 5.1 Field Blank/Equipment Blank Sample Collection

Field blank samples serve as a quality assurance check of equipment and field conditions at the time of sampling. Field blank samples are usually prepared by transferring analyte-free water into a clean set of sample containers, then analyzing it as a sample. Sometimes, the analyte-free water is transferred over or through the sampling device before it is placed into the sample containers. This type of field blank sample is known as an equipment blank. The QAPP contains specific information regarding the type and number of field blanks or equipment blanks required for collection.

### 5.2 Field Duplicate Sample Collection

Field duplicate samples are collected for the purpose of providing two sets of results for comparison. These samples are used to assess precision. Duplicate samples are usually prepared by splitting the sample into two sets of sample containers, then analyzing each set as a separate sample. The QAPP contains specific information regarding the type and number of duplicate samples for collection.

### 5.3 MS/MSD Sample Collection

MS/MSDs provide information about the effect of the sample matrix on digestion and measurement methodology. For samples submitted for MS/MSD analysis, triple sample volume is generally required (contact the analytical laboratory for information specific to the project analytical parameters). The QAPP contains specific information regarding the frequency of MS/MSD samples.

## 6.0 DOCUMENTATION

Specific information regarding sample collection should be documented in several areas: the sample chain-of-custody record, sample collection record, field logbook, and sample labels/tags. Additional information regarding each form of documentation is presented in the following paragraphs:

### 6.1 Sample Chain-of-Custody Record

This ENSR standard form requires input of specific information regarding each collected sample for laboratory analytical purposes. The information requested includes site name and location, project number, field logbook reference, collection date, and type of analysis requested. Each sample submitted for analysis is also listed individually using its field identification number, number and type of container, and requested analyses (see SOP 7510-04020).

## 6.2 Groundwater Sample Collection Record

This form (Attachment 1 or 2) requires input of specific information regarding the collection of each individual sample including sample identification, water quality parameters, collection method, and containers/preservation requirements.

## 6.3 Field Logbook

This logbook should be dedicated to the project and should be used by field personnel to maintain a general log of activities throughout the sampling program. This logbook should be used in support of, and in combination with, the sample collection record. Documentation within the logbook should be thorough and sufficiently detailed to present a concise, descriptive history of the sample collection process.

## 6.4 Sample Labels/Tags

Sample labels shall be completed at the time each sample is collected and attached to each sample container. Labels will include the information listed below.

- Client or project name/project number
- Sample number
- Sample designation
- Analysis type
- Preservative
- Sample collection date
- Sample collection time
- Sampler's name

The project-specific work plan may also require the use of sample tags that generally contain the same information as the sample labels. Sample tags, if used, should be tied to each sample bottle with wire ties.

## 7.0 TRAINING/QUALIFICATIONS

Groundwater sample collection is a relatively involved procedure requiring formal training and a variety of equipment. It is recommended that initial sampling attempts be supervised by more experienced personnel. Sampling technicians should be health and safety certified as specified by the Occupational Safety and Health Administration [OSHA; 29 CFR 1910.120(e)(3)(i)] to work on sites where hazardous waste materials are considered to be present.

## 8.0 REFERENCES

EPA, Handbook for Sampling and Sample Preservation of Water and Wastewater, EPA-600/4-82-029, September 1982.

EPA, RCRA Groundwater Monitoring Technical Enforcement Guidance, November 1992.

Geotrans, Inc., RCRA Permit Writer's Manual, Groundwater Protection, prepared for the U.S. EPA, Contract No. 68-01-6464, October 1983.

Code of Federal Regulations, Chapter 40 (Section 261.4(d)).

Puls, R.W. and Barcelona, 1996. Low Flow (Minimal Drawdown) Groundwater Sampling Procedures, U.S. EPA document EPA/540/S-95/504, April.

Yeskis, D. and Zavala, B., 2002. Ground-Water Sampling Guidelines for Superfund and RCRA Project Managers, Ground Water Forum Issue Paper, May 2002, 53 pages.

**Attachment 1  
Groundwater Sample Collection Record**



Well/Piezo ID: \_\_\_\_\_

**Ground Water Sample Collection Record**

|   |                         |
|---|-------------------------|
| Client: _____                           | Date: _____             |
| Project No: _____                       | Time: Start _____ am/pm |
| Site Location: _____                    | Finish _____ am/pm      |
| Weather Conds: _____ Collector(s) _____ |                         |

**WATER LEVEL DATA: (measured from Top of Casing)**      Well       Piezometer

a. Total Well Length \_\_\_\_\_      c. Casing Material \_\_\_\_\_      e. Length of Water Column \_\_\_\_\_

b. Water Table Depth \_\_\_\_\_      d. Casing Diameter \_\_\_\_\_      f. Calculated Well Volume (see back) \_\_\_\_\_

**WELL PURGING DATA**

a. Purge Method \_\_\_\_\_

b. Acceptance Criteria defined (from workplan)

- Minimum Required Purge Volume (@ \_\_\_\_\_ well volumes) \_\_\_\_\_
- Maximum Allowable Turbidity \_\_\_\_\_ NTUs
- Stabilization of parameters \_\_\_\_\_ %

c. Field Testing Equipment Used:      Make      Model      Serial Number

\_\_\_\_\_

d. Field Testing Equipment Calibration Documentation Found in Field Notebook # \_\_\_\_\_ Page # \_\_\_\_\_

| Time | Volume Removed (gal) | T° (C/F) | pH | Spec. Cond (umhos) | Turbidity (NTUs) | DO | Color | Odor | Other |
|------|----------------------|----------|----|--------------------|------------------|----|-------|------|-------|
|      |                      |          |    |                    |                  |    |       |      |       |
|      |                      |          |    |                    |                  |    |       |      |       |
|      |                      |          |    |                    |                  |    |       |      |       |
|      |                      |          |    |                    |                  |    |       |      |       |
|      |                      |          |    |                    |                  |    |       |      |       |
|      |                      |          |    |                    |                  |    |       |      |       |
|      |                      |          |    |                    |                  |    |       |      |       |

e. Acceptance criteria pass/fail

|                                     |                              |                             |                              |
|-------------------------------------|------------------------------|-----------------------------|------------------------------|
| Has required volume been removed    | Yes <input type="checkbox"/> | No <input type="checkbox"/> | N/A <input type="checkbox"/> |
| Has required turbidity been reached | <input type="checkbox"/>     | <input type="checkbox"/>    | <input type="checkbox"/>     |
| Have parameters stabilized          | <input type="checkbox"/>     | <input type="checkbox"/>    | <input type="checkbox"/>     |

if no or N/A - Explain below.

\_\_\_\_\_

**SAMPLE COLLECTION:**      Method: \_\_\_\_\_

| Sample ID | Container Type | No. of Containers | Preservation | Analysis | Time |
|-----------|----------------|-------------------|--------------|----------|------|
|           |                |                   |              |          |      |
|           |                |                   |              |          |      |
|           |                |                   |              |          |      |
|           |                |                   |              |          |      |
|           |                |                   |              |          |      |

Comments \_\_\_\_\_

Signature \_\_\_\_\_      Date \_\_\_\_\_

SOP NUMBER: 7130-04020

**Attachment 2  
Low Flow Ground Water Sample Collection Record**



Well ID: \_\_\_\_\_

**Low Flow Ground Water Sample Collection Record**

Client: \_\_\_\_\_ Date: \_\_\_\_\_ Time: Start \_\_\_\_\_ am/pm  
 Project No: \_\_\_\_\_ Finish \_\_\_\_\_ am/pm  
 Site Location: \_\_\_\_\_  
 Weather Conds: \_\_\_\_\_ Collector(s): \_\_\_\_\_

**1. WATER LEVEL DATA: (measured from Top of Casing)**

a. Total Well Length \_\_\_\_\_ c. Length of Water Column \_\_\_\_\_ (a-b) Casing Diameter/Material \_\_\_\_\_  
 b. Water Table Depth \_\_\_\_\_ d. Calculated System Volume (see back) \_\_\_\_\_

**2. WELL PURGE DATA**

a. Purge Method: \_\_\_\_\_

b. Acceptance Criteria defined (see workplan)

- Temperature 3% -D.O. 10%
- pH ± 1.0 unit - ORP ± 10mV
- Sp. Cond. 3% - Drawdown < 0.3'

c. Field Testing Equipment used:                      Make                      Model                      Serial Number

| Time<br>(24hr) | Volume              |               | pH | Spec. Cond.<br>(µS/cm) | DO<br>(mg/L) | ORP<br>(mV) | Turbidity<br>(NTU) | Flow Rate<br>(ml/min) | Drawdown<br>(feet) | Color/Odor |
|----------------|---------------------|---------------|----|------------------------|--------------|-------------|--------------------|-----------------------|--------------------|------------|
|                | Removed<br>(Liters) | Temp.<br>(°C) |    |                        |              |             |                    |                       |                    |            |
|                |                     |               |    |                        |              |             |                    |                       |                    |            |
|                |                     |               |    |                        |              |             |                    |                       |                    |            |
|                |                     |               |    |                        |              |             |                    |                       |                    |            |
|                |                     |               |    |                        |              |             |                    |                       |                    |            |
|                |                     |               |    |                        |              |             |                    |                       |                    |            |
|                |                     |               |    |                        |              |             |                    |                       |                    |            |
|                |                     |               |    |                        |              |             |                    |                       |                    |            |
|                |                     |               |    |                        |              |             |                    |                       |                    |            |

d. Acceptance criteria pass/fail                      Yes      No      N/A                      (continued on back)

Has required volume been removed                                 

Has required turbidity been reached                                 

Have parameters stabilized                                 

If no or N/A - Explain below.

\_\_\_\_\_

**3. SAMPLE COLLECTION:** Method: \_\_\_\_\_

| Sample ID | Container Type | No. of Containers | Preservation | Analysis Req. | Time |
|-----------|----------------|-------------------|--------------|---------------|------|
|           |                |                   |              |               |      |
|           |                |                   |              |               |      |
|           |                |                   |              |               |      |

Comments \_\_\_\_\_  
 \_\_\_\_\_  
 \_\_\_\_\_

Signature \_\_\_\_\_ Date \_\_\_\_\_





**SOP NUMBER: 7131-04020**

**Field Filtration of Water Samples for Inorganics**

**Date:** 3rd Qtr., 2003  
**Revision Number:** 1  
**Author:** A. Mischel  
**Discipline:** Water Resources

**1.0 PURPOSE AND APPLICABILITY**

This Standard Operating Procedure (SOP) is concerned with the field filtration of water samples for inorganic analyses. The specific analyses that require filtration will be defined in each project-specific work plan. The most common parameters requiring filtration, however, are dissolved metals and orthophosphate.

Respective state and/or federal agency (regional office) regulations may require specific types of equipment for use in sample filtration or variations in the indicated procedures. The U.S. Environmental Protection Agency (EPA) Resource Conservation and Recovery Act (RCRA) guidance has restrictions on groundwater filtration for example. EPA also defines "dissolved" constituents as anything that can pass through a 0.45-micron filter medium. Other state agencies (FL, CA) require use of larger diameter pore size (1.0 to 5.0-micron) filters and collection and analysis of both filtered and unfiltered samples. Modifications to this SOP to accommodate other regulatory requirements should be reviewed in advance of the field program and specified in the project work plan.

**1.1 General Principles**

Field filtration of water samples typically involves passing water from a sampling point through a filtration system to remove solids and other large diameter impurities. Generally, a pump and in-line disposable filter cartridge is used to filter the sample. Filtering can be accomplished directly from the sampling point or via some type of intermediate storage container. The resulting filtrate is discharged into approved sample containers, preserved (if required by the method), and submitted for analysis.

Prior to the advent of disposable filter cartridges, sample filtration was often accomplished using a tripod filter stand containing replaceable filter membranes that were under pressure. Use of the tripod filter stand was generally time consuming because it required decontamination after each use, frequent filter membrane changes and use of compressed nitrogen gas. This SOP no longer promotes use of this system although it may still be considered suitable for use as a backup system should filter cartridges be unavailable.

If a pump is being used to collect the sample, for example, from a monitoring well, that pump should also be used for filtration. That is, the in-line disposable filter cartridge should be placed along the pump discharge hose. Where this is not possible or if a pump is not being used for sample collection, it is recommended that a peristaltic pump be used to pass the water through the filter. The peristaltic is the pump of choice over other pumping systems for filtering because back pressure caused by gradual filter clogging will not affect the pump's integrity.

## 1.2 Quality Assurance Planning Considerations

Sampling personnel should follow specific quality assurance (QA) guidelines as outlined in the site-specific Quality Assurance Project Plan (QAPP). Proper QA requirements should be provided that will allow for collection of representative samples from representative sampling points. QA requirements typically include the collection of a sufficient quantity of quality control (QC) samples such as field duplicates and equipment rinsate blanks. These requirements should be outlined in the QAPP. Additional information regarding QC sample collection relevant to liquid material sampling is contained in Section 5.0 of this SOP.

## 1.3 Health and Safety Considerations

The health and safety considerations for the project, including both potential physical and chemical hazards, will be addressed in the site-specific Health and Safety Plan (HASP).

## 2.0 RESPONSIBILITIES

### 2.1 Sampling Technician

It is the responsibility of the sampling technician to be familiar with the sampling procedures outlined within this SOP and with specific sampling, QA, and health and safety requirements outlined within project-specific work plans (sampling plan, HASP, QAPP). The sampling technician is responsible for proper collection of samples and for documentation of sampling activities as samples are being collected.

### 2.2 Project Manager

The project manager is responsible for ensuring that project-specific requirements are communicated to the project team and for providing the materials, resources, and guidance necessary to perform the measurements in accordance with this SOP and the project plan.

## 3.0 REQUIRED MATERIALS

- Peristaltic pump (or other pump) with 12v power supply (if necessary)
- Silicone pump tubing (for peristaltic pumps – approximately 2 feet per sample)
- Polyethylene or other type of influent/discharge tubing (optional)
- Disposable 0.45-micron filter cartridges (high-capacity and/or low-capacity)
- Small hose clamps/screwdriver
- Sample kit, including bottles and preservatives (if needed)
- Chain-of-custody materials (forms, seals, labels)
- Intermediate sample containers
- Health and safety supplies
- Sample Collection Records

- Field project logbook/pen

## 4.0 METHOD

### 4.1 General Site Preparation

- 4.1.1** Sample filtration should be conducted in as clean an environment as possible but can be accomplished almost anywhere, including at the sampling point, the field vehicle, and/or at a remote or centralized sample handling area (i.e., the field trailer). The sample should be filtered as soon as possible after sample collection, before the sample chemistry changes, and prior to sample preservation (if required).
- 4.1.2** Prior to start of sample filtration, the sampling technician will set the equipment up and check that everything is operational. Set-up includes establishing the filtering location, hooking up the peristaltic pump to a power supply (if no internal battery supply is available), feeding a short length of pump tubing through the pump head, and attaching a filter cartridge with discharge arrow pointing in the direction of sample discharge. Additional information on pump set-up appears in the following section.

### 4.2 Pump Set-up

- 4.2.1** Place the pump on a stable surface and connect it to the available power supply (if required). Turn the pump on and vary the speed control knob to check that the pump is operational. The roller assembly should visibly change its rate of rotation as the speed control knob is turned. Keep the speed control knob set fairly low to install pump tubing. Switch the pump off.
- 4.2.2** Cut an approximate 2-foot length of clean silicone pump head tubing from the tubing roll. Loosen the three adjusting screws on the pump head assembly and pull the front cover forward to make it easier to feed the pump tubing. The cover/screws do not need to be removed completely.
- 4.2.3** Insert one end of the pump tubing into the pumphead assembly until it contacts the first roller. Switch the pump on so that the rollers turn in the direction that the tubing is being fed. The tubing should feed through the pump head assembly by itself; however, pushing on it slightly will help. Shut off the pump when the tubing is threaded through a sufficient length to allow the influent end to reach the intermediate sample container and the discharge end to reach the final sample bottle.
- 4.2.4** Tighten the screws on the pump head assembly.

### 4.3 Filtration Procedure

- 4.3.1** Filtration from Intermediate Containers
- Obtain a representative water sample following standard sample collection procedures and place it into an intermediate sample container. This container

should be of similar type and size as the final sample container. Depending on the final sample volume that is required, it may be necessary to collect excess sample volume for filtering. The container should be unpreserved. Cap the container and bring it to the sample filtration area.

- Select a new low-capacity or high-capacity filter cartridge based on the sample turbidity (if the sample is nearly clear, a low-capacity filter may suffice). Remove the filter from its wrapper and attach it to the discharge end of the pump tubing. Make sure that the filter flow direction, usually indicated by an arrow, points in the intended flow direction.
- Obtain a new sample bottle and place it on a stable platform. Check the tubing lengths on either side of the pumphead assembly at this time and adjust them as necessary by loosening the pump head assembly screws and pulling on the tubing.
- Remove the cap from both containers then insert the influent end of the pump head tubing (i.e., intake line) into the intermediate sample container so that it is at least one-third of the way into the container. Pumping from the upper third of the intermediate container, then gradually lowering the intake line into the container, will help extend the life of the filter.
- Start the pump with the speed control knob set to a fairly low speed and observe the rate of flow through the tubing. Allow 50 to 100 milliliters of water to pass through the filter into a waste container. This will flush any residual water from the manufacturing process through the filter.
- Transfer the discharge end of the filter cartridge to the top of the final sample container. As filtration proceeds, gradually lower the intake line until the sample has been filtered. Replace the filter if necessary at any time during the filtration procedure (see Section 4.4). Fill the final container to the desired level.
- Cap and label the sample container and discard the intermediate container, filter, and pump head tubing.

#### 4.3.2 Surface Water Sample Filtration

If surface water sample collection and filtration is performed using a peristaltic pump, the apparatus and procedures are the same as for other samples. The only significant difference is that when collecting a surface water sample in this manner, the sampling technician must be sure that the pump intake line is positioned at the desired location and depth. It may be necessary to collect subsurface water samples at specific depths in this manner; however, it may be easier to collect surface water samples into intermediate sample containers than to obtain a filtered sample directly from the surface water body.

### 4.3.3 Filtration of Samples from Wells

If a submersible pump is being used for sample collection, the in-line filter cartridge can be attached to the pump discharge line or an alternate method may be used to collect the sample using intermediate sample containers. The peristaltic pump has a suction limit of approximately 20 feet. If the water level in the well is below that limit, a peristaltic pump cannot be used to collect samples.

If a peristaltic pump is used to obtain a filtered sample directly from the sampling point, such as a well, an additional length of pump head tubing (silicone) or alternative type of tubing will be required to reach the sampling point or water column. Small diameter polyethylene tubing should be used in place of silicone tubing as it is much less expensive. This tubing should be of the correct diameter to insert directly into the intake end of the pump head tubing. Clamp the tubing if necessary. Filtration is then conducted following the same procedures as outlined in Section 4.3.1 (except for language that pertains to use of intermediate sample containers).

## 4.4 Filter Replacement

- 4.4.1 High sample turbidity may cause clogging of the filter membranes, a decrease in filtration efficiency/rate, and occasionally such a high pressure that the filter cartridge is prematurely released from the pump head tubing. If the rate of flow is observed to decrease substantially, then it is recommended that the filter be replaced. In order to do this safely, the following steps should be followed.
- 4.4.2 Remove the discharge end from the sample container. Turn the pump off, then reverse the pump head rotation direction by using the forward/reverse switch. Turn the pump back on to release backpressure from the filter and tubing. Turn the pump off again and remove the old filter.
- 4.4.3 Obtain a new filter and install it as indicated in Section 4.3 including pumping 50 to 100 milliliters of sample water through the filter into a waste container. Resume filtering.

## 5.0 QUALITY CONTROL

### 5.1 Equipment Rinsate Blank Collection

Equipment rinsate blank samples serve as QC checks of equipment and field conditions at the time of sampling. An equipment rinsate blank is typically collected by transferring analyte-free water over or through the sampling device before it is placed into the sample containers and submitted to the laboratory for analysis of the same parameters as the associated field samples.

Equipment rinsate blank samples of filtration equipment are generally prepared by pumping analyte-free water through a clean section of pump head tubing with a clean filter attached. The sample should be collected in the same manner as the other field samples. The pump head tubing and filter may be reused on the next sample as collection of the field blank has not contaminated the filtration materials.

Equipment rinsate blanks are typically collected at a frequency of one per day, or one per 10 field samples. The QAPP will contain specific information regarding the frequency of equipment rinsate blanks.

## **5.2 Field Duplicate Collection**

Field duplicate samples provide a measure of the overall precision (i.e., the error associated with both sampling and analysis). Field duplicates are collected by alternatively filling two identical sample containers from the source being sampled. The two containers are then assigned unique sample IDs and submitted for analysis as individual samples. Field duplicates are typically analyzed for the same parameters as the associated field samples.

Field duplicates are typically collected at a frequency of one per 10 or 20 field samples. The QAPP will contain specific information regarding the frequency of field duplicate samples.

## **6.0 DOCUMENTATION**

Specific information regarding filtered water sample collection will be documented on the sample collection record and the field project logbook.

### **6.1 Sample Collection Record**

This form requires input of specific information regarding the collection of each individual sample including sample identification; sample type; collection method; containers; parameters to be analyzed; sample preservation method; sample collection time; time of sample filtration; and type, size, and number of filters used. Any deviations from the approved work plan or this SOP must be documented on the sample collection record or in the field logbook.

### **6.2 Field Logbook**

The logbook will be dedicated to the project and will be used by sampling personnel to maintain a general log of activities throughout the sampling program. This logbook should be used in support of, and in combination with, the sample collection record. Documentation within the logbook should be thorough and sufficiently detailed to present a concise, descriptive history of the sample collection process including specific information regarding the sample filtration equipment used.

## 7.0 TRAINING/QUALIFICATIONS

Sample filtration is a relatively simple procedure requiring minimal training and a minimal amount of equipment. It is, however, recommended that initial sampling attempts be supervised by more experienced personnel. Sampling technicians should be health and safety certified as specified by the Occupational Safety and Health Administration [OSHA; 29 CFR 1910.120(e)(3)(i)] to work on sites where hazardous waste materials are considered to be present.

## 8.0 REFERENCES

American Society for Testing and Materials (ASTM). ASTM Standards on Environmental Sampling. Standard Guide for Sampling Groundwater Monitoring Wells (D 4448). 1995.

APHA-AWWA-WEF. Standard Methods for the Examination of Water and Wastewater, 18<sup>th</sup> Edition. 1992.

Florida Department of Environmental Protection. Standard Operating Procedure FS 2000, General Aqueous Sampling. January 1, 2002.

U.S. Environmental Protection Agency (EPA). Ground-Water Sampling Guidelines for Superfund and RCRA Project Managers, Ground Water Forum Issue Paper. May 2002.

U.S. Environmental Protection Agency (EPA). RCRA Ground-Water Monitoring: Draft Technical Guidance. November 1992.



## APPENDIX: DEFINITIONS

**Filter Cartridges** – In line 0.45-micron disposable filter cartridges are commercially available as a substitute to the former filter stand apparatus with replaceable filter membranes. The cartridges contain an inert filter membrane material sealed within a polyethylene case. The influent and effluent ports contain fittings for tubing attachment. Two types of cartridges are available, a low-capacity cartridge with 20 cubic centimeters (cm<sup>2</sup>) of effective filtration area, and a high-capacity cartridge with 700 cm<sup>2</sup> of filtration area. Low-capacity cartridges are effective only with low- to no-visible turbidity within the sample. High-capacity cartridges, which are more expensive, are suitable for a wide range of sample turbidity. Larger pore size filter cartridges are also commercially available. These should not be used unless specifically required in the sampling plan.

**Influent/Discharge Tubing** - Silicone pump tubing is generally too expensive to use for influent and/or discharge tubing if, for instance, pumping samples directly from a well is required. Polyethylene tubing of a slightly narrower outside diameter than the silicone tubing may be used for influent/discharge tubing, if necessary. The two types of tubing can usually be joined without clamps as silicone tubing is very flexible and sticky.

**Intermediate Sample Containers** - Intermediate sample containers generally consist of a clean unpreserved sample container of equal or larger volume and type that is used to temporarily store the sample until it is filtered. The sample is usually filtered directly from the intermediate containers into the final sample container. Intermediate sample containers should be disposed of after each use. An adequate supply of sample containers should be available to meet project requirements.

**Peristaltic Pump** - This type of pump is a low volume pump that operates by progressively squeezing the water sample through a silicon tube by means of three rollers that revolve within a housing. The advantage of this type of pump is that the sample never contacts any mechanical parts of the pump.

**Pump Tubing** - The pump tubing is made of silicone with a specific inside and outside diameter that matches the pump head design. Be sure to check the pump head number against the tubing number. These numbers should be the same and are located on the pump roller housing and on the tubing package respectively. Use of the wrong tubing will either diminish the effectiveness of the pump or will cause it to stop operating entirely.

**SOP NUMBER: 7221-04020**

## Monitoring Well Development

**Date:** September 22, 2006  
**Revision Number:** 3  
**Author:** Sally Bilodeau  
**Discipline:** Geosciences

### 1.0 PURPOSE AND APPLICABILITY

This standard operating procedure (SOP) describes the methods used for developing newly installed monitoring wells and/or existing wells that may require redevelopment/rehabilitation. This SOP is applicable to monitoring wells and/or small diameter recovery wells and piezometers.

Monitoring well development and/or redevelopment is necessary for several reasons:

- To improve/restore hydraulic conductivity of the surrounding formations as they have likely been disturbed during the drilling process or may have become partially plugged with silt;
- To remove drilling fluids (water, mud), when used, from the borehole and surrounding formations; and
- To remove residual fines from well filter materials and reduce turbidity of groundwater, therefore, reducing the chance of chemical alteration of groundwater samples caused by suspended sediments.

Respective state or federal agency (regional offices) regulations may require specific types of equipment for use or variations in the indicated method of well development. Deviations from this SOP to accommodate other regulatory requirements should be reviewed in advance of the field program, should be explained in the project work plan, and must be documented in the field project logbook when they occur.

#### 1.1 General Principles

Well development generally involves withdrawal of an unspecified volume of water from a well using a pump, surge block, or other suitable method such that, when completed effectively, the well is in good or restored hydraulic connection with the surrounding water bearing unit and is suitable for obtaining representative groundwater samples or for other testing purposes.

#### 1.2 Quality Assurance Planning Considerations

Field project personnel should follow specific quality assurance guidelines as outlined in the site-specific Quality Assurance Project Plan (QAPP) and/or Sampling Plan. The plan should indicate the preferred method of well development at a particular site based on project objectives, aquifer conditions, and agency requirements. Specific well performance criteria, such as low turbidity values to be achieved following well development, should also be

specified as well as any requirements for collection/containerization and disposal of well development water.

### **1.3 Health and Safety Considerations**

Monitoring well development may involve chemical hazards associated with materials in the soil or aquifer being characterized and may involve physical hazards associated with use of well development equipment. When wells are to be installed and developed on hazardous waste investigation sites, a Health and Safety Plan must be prepared and approved by the Health and Safety Officer before field work commences, must be distributed to all field project personnel, and must be adhered to as field activities are performed.

## **2.0 RESPONSIBILITIES**

### **2.1 Project Geologist/Engineer**

Development or oversight of development of new monitoring wells is the responsibility of the project geologist/engineer involved in the original installation of the well. Records of well development methods and results will be retained in the project file.

### **2.2 Project Manager**

The project manager is responsible for ensuring that the appropriate method of well development has been chosen that best meets project objectives, site hydrogeologic conditions, and/or relevant regulatory requirements.

## **3.0 REQUIRED MATERIALS**

Well development can be performed using a variety of methods and equipment. The specific method chosen for development of any given well is governed by the purpose of the well, well diameter and materials, depth, accessibility, geologic conditions, static water level in the well, and type of contaminants present, if any.

The following equipment, each with their own particular application, may be used to develop and/or purge monitoring wells.

### **3.1 Bailer Purging**

A bailer is used to purge silt-laden water from wells after using other devices such as a surge block. In some situations, the bailer can be used to develop a well by bailing and surging, often accompanied with pumping. A bailer should be used for purging in situations where the depth to static water is greater than 25 feet and/or where insufficient hydraulic head is available for use of other development methods.

### 3.2 Surge Block Development

Surge blocks are commercially available for use with Waterra™-type pumping systems or may be manufactured using a rubber or Teflon "plunger" attached to a rod or pipe of sufficient length to reach the bottom of the well. Well drillers usually can provide surge blocks if requested. A recommended design is shown in Figure 1.

### 3.3 Pump Development

A pump is often necessary to remove large quantities of silt-laden groundwater from a well after using the surge block. In some situations, the pump alone can be used to develop the well and remove the fines by overpumping. Since the purpose of well development is to remove suspended solids from a well and surrounding filter pack, the pump must be capable of moving some solids without damage. The preferred pump is a submersible pump that can be used in both shallow and deep groundwater situations. A centrifugal pump may be used in shallow wells but will work only where the depth to static groundwater is less than approximately 25 feet. Pumping may not be successful in low-yielding aquifer materials or in wells with insufficient hydraulic head.

### 3.4 Compressed Gas Development

Compressed gas, generally nitrogen from a tank or compressed air through a compressor, can be used to both surge and develop a monitoring well. The method works by injection of compressed gas at the bottom of the water column, driving sediment-laden water to the surface. Compressed gas can also be used for "jetting" – a process by which the gas is directed at the slots in the well screen to cause turbulence (thereby disturbing fine materials in the adjacent filter pack). Compressed gas is not limited by any depth range.

Since the compressed gas will be used to "lift" water from the monitoring well, provisions must be made for controlling the discharge from contaminated wells. This is generally accomplished by attaching a "tee" discharge to the top of the casing and providing drums to contain the discharged water. Gas-lifting should never be done in contaminated wells without providing a means to control discharge.

### 3.5 Other Required Materials

- Well development records (Figure 2)
- Health and Safety equipment
- Equipment decontamination materials
- Water quality instrumentation: nephelometer, pH, temperature, specific conductance meters, as required
- Field project logbook/pen

## 4.0 METHOD

### 4.1 General Preparation

- 4.1.1 Well Records Review:** Well completion diagrams should be reviewed to determine well construction characteristics. Formation characteristics should also be determined from review of available boring logs.
- 4.1.2 Site Preparation:** Well development, similar to groundwater sampling, should be conducted in as clean an environment as possible. This usually requires, at a minimum, placing sheet plastic on the ground to provide a clean working area for development equipment.
- 4.1.3 IDW Containment:** Provisions should be in place for collection and management of investigation-derived waste (IDW), specifically well development water and miscellaneous expendable materials generated during the development process. The collection of IDW in drums or tanks may be required depending on project-specific requirements. The QAPP should specify the requirements for IDW containment.
- 4.1.4 Water Level/Well Depth Measurement:** The water level and well depth should be measured with a water level indicator and written on the well development record. This information is used to calculate the volume of standing water (i.e., the well volume) within the well.
- 4.1.5 Equipment Decontamination:** All down-well equipment should be decontaminated prior to use in accordance with ENSR SOP-7600-04020 (Decontamination of Field Equipment).
- 4.1.6 Removal of Drilling Fluids:** Drilling fluids such as mud or water, if used during the drilling and well installation process, should be removed during the well development procedure. It is recommended that a minimum of 1.5 times the volume of added fluid be removed from the well during development. Drilling muds should initially have been flushed from the drilling casing during the well installation procedure with water added during the flushing process. If the quantity of added fluid is not known or could not be reasonably estimated, removal of a minimum of 10 well volumes of water is recommended during the development procedure.

### 4.2 Development Procedures

#### 4.2.1 Development Method Selection

The construction details of each well shall be used to define the most suitable method of well development. Some consideration should be given to the potential

degree of contamination in each well as this will impact IDW containment requirements.

The criteria for selecting a well development method include well diameter, total well depth, static water depth, screen length, the likelihood and level of contamination, and characteristics of the geologic formation adjacent to the screened interval.

The limitations, if any, of a specific procedure are discussed within each of the following procedures.

#### **4.2.2 General Water Quality Measurements**

Measure and record water temperature, pH, specific conductance, and turbidity periodically during development using the available water quality instruments. These measurements will aid in determining whether well development is proceeding efficiently, will assist in identifying when well development is complete, will determine whether the development process is effective or not with any given well and, potentially, may identify well construction irregularities (i.e., grout in well, poor well screen slot-size selection). Water quality parameters should be checked a minimum of 3 to 5 times during the development process.

#### **4.2.3 Bailer Procedure**

- As stated previously, bailers shall preferably not be used for well development but may be used in combination with a surge block to remove silt-laden water from the well.
- When using a bailer to purge well water, select the appropriate bailer, then tie a length of bailer cord onto the end of it.
- Lower the bailer into the screened interval of the monitoring well. Silt, if present, will generally accumulate within the lower portions of the well screen.
- The bailer may be raised and lowered repeatedly in the screened interval to further simulate the action of a surge block and pull silt through the well screen.
- Remove the bailer from the well and empty it into the appropriate storage container.
- Continue surging/bailing the well until sediment-free water is obtained. If moderate to heavy siltation is still present, the surge block procedure should be repeated and followed again with bailing.
- Check water quality parameters periodically.

#### 4.2.4 Surge Block Procedure

- A surge block effectively develops most monitoring wells. This device first forces water within the well through the well screen and out into the formation, and then pulls water back through the screen into the well along with fine soil particles. Surge blocks may be manufactured to meet the design criteria shown in the example (Figure 1) or may be purchased as an adaptor to fit commercially available well purging systems such as the Waterra® system.
- Insert the surge block into the well and lower it slowly to the level of static water. Start the surge action slowly and gently above the well screen using the water column to transmit the surge action to the screened interval. A slow initial surging, using plunger strokes of approximately 3 feet, will allow material that is blocking the screen to separate and become suspended.
- After 5 to 10 plunger strokes, remove the surge block and purge the well using a pump or bailer. The returned water should be heavily laden with suspended silt and clay particles. Discharge the purged water into the appropriate storage container.
- Repeat the process. As development continues, slowly increase the depth of surging to the bottom of the well screen. For monitoring wells with long screens (greater than 10 feet) surging should be undertaken along the entire screen length in short intervals (2 to 3 feet) at a time. Continue this cycle of surging and purging until the water yielded by the well is free of visible suspended material.
- Check water quality parameters periodically.

#### 4.2.5 Pump Procedure

- Well development using only a pump is most effective in monitoring wells that will yield water continuously. Theoretically, pumping will increase the hydraulic gradient and velocity of groundwater near the well by drawing the water level down. The increased velocity will move residual fine soil particles into the well and clear the well screen of this material. Effective development cannot be accomplished if the pump has to be shut off to allow the well to recharge.
- When using a submersible pump or surface pump, set the intake of the pump or intake line in the center of the screened interval of the monitoring well.
- Pump a minimum of three well volumes of water from the well and raise and lower the pump line through the screened interval to remove any silt/laden water.

- Continue pumping water from the well until sediment-free water is obtained. This method may be combined with the manual surge block method if well yield is not rapid enough to extract silt from the surrounding formations.
- Check water quality parameters periodically.

#### 4.2.6 Compressed Gas Procedure

- Although the equipment used to develop a well using this method is more difficult to obtain and use, well development using compressed gas is considered to be a very effective method. This method is also not limited by well depth, well diameter, or depth to static water. Caution must be exercised, however, in highly permeable formations not to inject gas into the formation. Drilling subcontractors will often provide the necessary materials as well as perform this method, if requested. When using a compressor, an oil-less compressor should be used or an oil trap/filter should be placed on the air discharge line that enters the well.
- Lower the gas line into the well, setting it near the bottom of the screened interval. Install the discharge control equipment (i.e., tee fitting) at the well head.
- Set the gas flow rate to allow continuous discharge of water from the well.
- At intervals during gas-lifting, especially when the discharge begins to contain less suspended material, shut off the air flow and allow the water in the well to backflush through the screened interval to disturb any bridging that may have occurred. Re-establish the gas flow when the water level in the well has returned to the pre-development level.
- Continue gas-lifting and/or jetting until the discharged water is free from suspended material.
- Check water quality parameters periodically.

## 5.0 QUALITY CONTROL

A well has been successfully developed when one or more of the following criteria are met:

- The sediment load in the well has been eliminated or greatly reduced. Regulatory requirements may be in place stating that water turbidity values ranging from 5 to 50 nephelometric turbidity units (NTUs) must be achieved at the end of the development procedure. Use of a nephelometer is required during the well development procedure to measure water turbidity if meeting a specific turbidity value is required by the regulations. Attaining low turbidity values in fine-grained formations may be difficult to achieve.



- Permeability tests conducted in accordance with ENSR - 7720-04020 (Hydraulic Conductivity Tests – Pressure Transducer Method) yield repeatable hydraulic conductivity values.

## 6.0 DOCUMENTATION

The Monitoring Well Development Record (Figure 2) will be completed by the geologist or hydrogeologist conducting the development. In addition, a field project logbook should be maintained detailing any problems or unusual conditions that may have occurred during the development process.

## 7.0 TRAINING/QUALIFICATIONS

Well development procedures vary in complexity. It is recommended that initial development attempts be supervised by more experienced personnel. Field personnel should be health and safety certified as specified by the Occupational Safety And Health Administration [OSHA; 29 CFR 1910.120(e)(3)(i)] to work on sites where hazardous waste materials are considered to be present.

## 8.0 REFERENCES

### Standard References for Monitoring Wells,

U.S. Environmental Protection Agency. Introduction to Groundwater Monitoring (40 CFR Parts 264/265, Subpart F). RCRA, Superfund & EPCRA Call Center Training Module. October 2001.

Department of Toxic Substances Control Hazardous Waste Management Program. Guidance Document Monitoring Requirements for Permitted Hazardous Waste Facilities. July 2001.

## APPENDIX: DEFINITIONS

**Bridging:** A condition within the filter pack outside the well screen whereby the smaller particles are wedged together in a manner that causes blockage of pore spaces.

**Hydraulic Conductivity:** a characteristic property of aquifer materials that describes the permeability of the material with respect to flow of water.

**Hydraulic Connection:** A properly installed and developed monitoring well should have good hydraulic connection with the aquifer. The well screen and filter material should not provide any restriction to the flow of water from the aquifer into the well.

**Permeability Test:** Used to determine the hydraulic conductivity of the aquifer formation near a well screen. Permeability testing is generally conducted by displacing the water level in a well and monitoring the rate of recovery of the water level as it returns to equilibrium. Various methods of analysis are available to calculate the hydraulic conductivity from these data.

**Static Water Level:** The water level in a well that represents an equilibrium or stabilized condition, usually with respect to atmospheric conditions in the case of monitoring wells.

**Well Surging:** That process of moving water in and out of a well screen to remove fine sand, silt, and clay size particles from the adjacent formation.

**Well Purging:** The process of removing standing water from a well to allow surrounding formation water to enter the well.

**Well Screen:** That portion of the well casing material that is perforated in some manner so as to provide a hydraulic connection to the aquifer. The perforated, or slotted, portion of a well is also known as the screened interval.

**Figure 1**  
**Recommended Surge Block Design**

**SURGE BLOCK DESIGN**  
 (Not to Scale)

Steel washers should be 1/2" to 3/4" smaller in diameter than the well ID. Gasket can be rubber or leather and should be the same diameter or 1/8" smaller than the well ID to compensate for swelling of the leather/ Rod can be steel, fiberglass, or plastic but must be strong and lightweight.

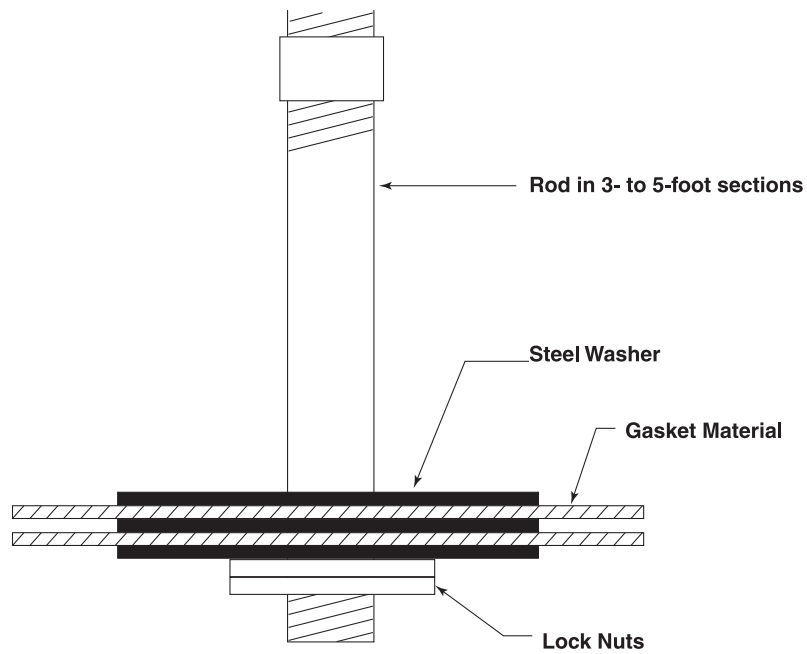

SOP NUMBER: 7221-04020

**Figure 2  
Well Development Record**



Well/Piez. ID: \_\_\_\_\_

**Well/Piezometer Development Record**

Client: \_\_\_\_\_ Site Location: \_\_\_\_\_  
 Project No: \_\_\_\_\_ Date: \_\_\_\_\_ Developer: \_\_\_\_\_

**WELL/PIEZOMETER DATA**

Well  Piezometer  Diameter \_\_\_\_\_ Material \_\_\_\_\_  
 Measuring Point Description \_\_\_\_\_ Geology at Screen Interval (if known) \_\_\_\_\_  
 Depth to Top of Screen (ft.) \_\_\_\_\_  
 Depth to Bottom of Screen (ft.) \_\_\_\_\_ Time of Water Level Measurement \_\_\_\_\_  
 Total Well Depth (ft.) \_\_\_\_\_ Calculate Purge Volume (gal.) \_\_\_\_\_  
 Depth to Static Water Level (ft.) \_\_\_\_\_ Disposal Method \_\_\_\_\_  
 Wellhead PID/FID \_\_\_\_\_  
 Original Well Development  Redevelopment  Date of Original Development \_\_\_\_\_

**DEVELOPMENT METHOD**

**PURGE METHOD**

Field Testing Equipment Used: \_\_\_\_\_ Make \_\_\_\_\_ Model \_\_\_\_\_ Serial Number \_\_\_\_\_

Field Testing Calibration Documentation Found in Field Notebook # \_\_\_\_\_ Page # \_\_\_\_\_

| Time | Volume Removed (gal) | T° (C/F) | pH | Spec. Cond (umhos) | Turbidity (NTUs) | DO | Color | Odor | Other |
|------|----------------------|----------|----|--------------------|------------------|----|-------|------|-------|
|      |                      |          |    |                    |                  |    |       |      |       |
|      |                      |          |    |                    |                  |    |       |      |       |
|      |                      |          |    |                    |                  |    |       |      |       |
|      |                      |          |    |                    |                  |    |       |      |       |
|      |                      |          |    |                    |                  |    |       |      |       |
|      |                      |          |    |                    |                  |    |       |      |       |
|      |                      |          |    |                    |                  |    |       |      |       |
|      |                      |          |    |                    |                  |    |       |      |       |
|      |                      |          |    |                    |                  |    |       |      |       |
|      |                      |          |    |                    |                  |    |       |      |       |

**ACCEPTANCE CRITERIA (from workplan)**

|   |                                     |   |
|---|-------------------------------------|---|
| Min. Purge Volume ( _____ well volumes) _____ gallons | Has required volume been removed    | Yes <input type="checkbox"/> No <input type="checkbox"/> N/A <input type="checkbox"/> |
| Maximum Turbidity Allowed _____ NTUs                  | Has required turbidity been reached | <input type="checkbox"/> <input type="checkbox"/> <input type="checkbox"/>            |
| Stabilization of parameters _____%                    | Have parameters stabilized          | <input type="checkbox"/> <input type="checkbox"/> <input type="checkbox"/>            |

If no or N/A explain below:  
 \_\_\_\_\_  
 \_\_\_\_\_  
 \_\_\_\_\_

Signature \_\_\_\_\_ Date: \_\_\_\_\_

**SOP NUMBER: 7230-04020**

**Test Pits/Trench Subsurface Exploration**

**Date:** September 22, 2006  
**Revision Number:** 3  
**Author:** Sally Bilodeau  
**Discipline:** Geosciences

**1.0 INTRODUCTION**

**1.1 Purpose and Applicability**

This Standard Operating Procedure (SOP) describes the methods for excavating and logging test pits or trenches. Test pits/trenches are generally excavated to visually determine subsurface soil and rock conditions and for environmental sampling. Test pits/trenches are generally excavated by a qualified subcontractor under the direction of the project geologist.

The purpose of this SOP is to provide a specific method and/or procedure to be used for test pit excavation, soil sample collection, and test pit logging. If followed properly, use of this SOP will promote consistency in each of the above areas.

This SOP is applicable to test pit/trench excavations that are usually completed with a backhoe. Test pits/trenches are generally completed to shallow depths (up to 10 feet approximately) and usually within unconsolidated materials, including, but not limited to, native materials (sand, gravel, silt, clay), fill materials, and weathered bedrock.

**1.2 General Principles**

Test pit/trench subsurface explorations generally involve use of backhoes to perform excavations for the purpose of visually assessing subsurface soil/fill conditions and to allow for collection of representative soil samples. The excavation subcontractor is directed by the project geologist/engineer to complete a test pit/trench at a designated location. The lateral extent and depth of the test pit/trench is dependent upon project objectives. Once excavated, the test pit/trench is logged and sampled, if required. Following this, the test pit/trench is backfilled with the excavated material or with clean fill.

**1.3 Quality Assurance Planning Considerations**

Project personnel should follow specific quality assurance guidelines for sampling as outlined in the site-specific Quality Assurance Project Plan (QAPP) and/or Sampling Plan. Proper quality assurance requirements should be provided that will allow for collection of representative samples from representative sampling points. Quality assurance requirements typically suggest the collection of a sufficient quantity of field duplicate, field blank, and equipment blank samples.

## 1.4 Health and Safety Considerations

All utilities (electric, water, sewer, etc.) or property owners who may have equipment or transmission lines buried in the vicinity of proposed test pits should be notified. Many regions have organizations that represent all utilities for these notification purposes. Sufficient time should be allowed after notification (typically 3 working days) for the utilities to respond and mark locations of any equipment that may be buried on site. It should be noted, however, that these organizations may not be responsible for locating utilities on private property. This is often the responsibility of the property owner. The estimated location of utility installations, such as sewer, telephone, electric, water lines and other underground installations that may reasonably be expected to be encountered during excavation work, shall be verified by the site owner prior to opening an excavation. The subcontractors will be made aware of the potential of encountering underground utilities at each test pit location.

To avoid the hazards associated with the cave-in or collapse of an excavation or trench, ENSR employees will not enter an excavation or trench to collect the required samples. Samples will be collected remotely, using long-handled sampling tools, or directly from the bucket of the backhoe. If entry becomes necessary and the excavation is greater than 5 feet in depth, the contractor will be required to slope or shore the walls of the excavation. Specific requirements will depend on soil type and site constraints, and will be addressed in the site-specific health and safety plan (HASP). All sloping or shoring must be conducted in compliance with the Occupational Safety and Health Administration (OSHA) rules for trenching and excavation (29 CFR 1926.650-652.)

For safety reasons in case of sidewall collapse, all personnel and materials will be kept at least 2 feet from the edge of any open excavation. Open excavations can be viewed by the geologist from test pit endwalls, which are more stable than test pit sidewalls.

If excavations are to be left open temporarily, the perimeter of the excavation must be marked with "Caution-Open Trench" tape. Other site-specific restrictions on leaving test pits open temporarily may be required by the property owner. Those requirements should be determined prior to startup of the excavation program.

Ambient air quality conditions should be periodically monitored both within and surrounding the excavation for potentially toxic and/or explosive atmospheric conditions. The project HASP should be reviewed for specific information regarding ambient air quality monitoring.

## 2.0 RESPONSIBILITIES

### 2.1 Project Manager

The project manager will be responsible for ensuring that the project-specific requirements are communicated to the project team and for providing the materials, resources, and guidance necessary to perform the work in accordance with this SOP and the project plan.

## 2.2 Project Geologist/Engineer

It will be the responsibility of the geologist or engineer to determine the location, total depth, and overall size of each test pit/trench. It will also be his or her responsibility to collect representative samples from the test pit/trench and to log the test pit/trench according to the procedures described in this SOP.

## 2.3 Subcontractor

It will be the responsibility of subcontractors to construct test pits/trenches according to ENSR project-specific requirements and in accordance with OSHA safety requirements for trench construction.

## 3.0 REQUIRED MATERIALS

- Stakes
- Fluorescent flagging tape/caution tape
- Sample kit (i.e., bottles/labels, custody records, cooler, ice, etc.)
- Measuring tape
- Compass (optional)
- Camera
- Sheet plastic
- Sampling equipment: spoons, trowels, scoops, shovels
- Field records: test pit log, test pit profile log
- Field logbook/pen
- Project plans (HASP, QAPP, Sampling Plan)
- Decontamination materials and solutions
- Personal protective equipment (as required by HASP)

## 4.0 METHOD

### 4.1 General Preparation

General locations for test pits or trenches should be marked with a stake and/or flagging tape prior to start of the excavation program. Final post-excavation locations should be documented by using topographic maps and/or other site plans. Final locations should also be measured from a fixed feature or surveyed if necessary.

Excavation equipment should be properly decontaminated prior to initial use, between test pit/trench excavations, and following completion of the last excavation. It should be noted that excavation equipment may need to be brushed clean or fully decontaminated at the completed test pit location if the potential exists for spreading contaminated soils by transport of the excavation equipment.

## 4.2 Excavation

Test pits/trenches will be excavated to the depth specified in the project-specific plan. Test pit completion depths should be indicated to the subcontractor by the project geologist or engineer. The test pits or trenches will be excavated in compliance with applicable safety regulations. Walls should initially be cut as near vertical as possible to facilitate stratigraphic mapping. Proper sidewall sloping will, however, be required for test pits that extend beyond 5 feet in depth if sampling or logging personnel require access to the open excavation.

As the test pit/trench is excavated, the excavated soils should be placed to one side of the excavation and no closer than 2 to 3 feet from the excavation's edge. Depending on the project requirements, sheet plastic may be required to cover the ground surface before placing excavation soils on the ground.

Excavation should proceed slowly and with caution. The project geologist/engineer should view the excavation (from the far end wall) after each removed bucket of soil for the presence of unusual features such as waste accumulations, free liquids (water or free product), and buried utilities. The excavation subcontractor should continue the excavation only after receiving approval to proceed from the project geologist/engineer.

## 4.3 Logging

A test pit log will be prepared in the field by the geologist or engineer. The test pit log, which is similar to a boring log, will include notations on soil types and depth of stratigraphic changes, depth to water table, identification of waste materials, and the depth/location of any environmental samples that were collected. The dimensions and orientation of each test pit/trench will also be recorded on the test pit log.

A supplemental sketch is often necessary to depict the physical orientation of the strata encountered. These observations should be recorded on the test pit profile log. The test pit profile log allows for sketching a view of the test pit sidewall (i.e., a test pit cross section) and for listing of sample collection information.

The project geologist/engineer will measure the depth to the groundwater table in test pits, if encountered, only after sufficient time is allowed for stabilization of the groundwater table. If there is insufficient time to achieve stabilization, the depth to where groundwater is entering the test pit should be indicated on the logs.

If photographs are necessary, they can be taken at this time.

## 4.4 Sample Collection

Requirements for soil sampling will be determined by the project geologist/engineer in accordance with the project sampling plan.



Soil samples may be collected for several reasons including stratigraphic logging, field headspace organic vapor testing, and laboratory environmental testing. Various types of sampling equipment are commonly available for use in sample collection. SOP 7110-04020 (Surface Soil Sampling) provides instruction in the use of scoops, trowels, shovels, and other types of soil sampling equipment. Guidance on decontamination of field equipment is provided in SOP 7600-04020.

Soil samples may be collected from test pits/trenches from several locations: the test pit/trench sidewalls or base, the excavated soil pile, or directly from the backhoe bucket. Additional information regarding each sampling method are presented in the following subsections.

#### **4.4.1 Test Pit/Trench Sidewall or Base Sampling**

Test pit/trench sidewall or base sampling is generally the preferred method by regulatory agencies because it allows for in-situ sampling of soils. In-situ sampling limits the potential for sample contamination, which can occur during the excavation procedures. This method, valid for any type of proposed analysis, is especially preferred for samples that will be analyzed for volatile organic compounds (VOCs).

Sidewall or base sampling is considered to be somewhat more dangerous than sampling from the soil pile or backhoe bucket because it may require entry of sampling personnel into the excavation. A recommended option in place of entry into the excavation is to use long-handled sampling equipment. The use of long-handled sampling equipment allows for collection of samples without entry into the excavation and often from the excavation ends where it is generally considered safe. Long-handled sampling equipment can be fabricated using standard surface soil sampling equipment (trowels, scoops, etc.) attached to long wooden or aluminum extension handles with duct tape or clamps. When using duct tape, or any kind of tape, caution should be exercised during sampling not letting the sample come into contact with the tape or handle.

Regardless of whether entry into the excavation is required, sampling should be conducted in the following manner:

- Select the sampling location and “dress” the excavation surface by scraping to remove any loose surface soil or smearing residues.
- Replace the dressing tool with a clean sampling tool.
- Collect the soil sample with the sampling tool in accordance with the methods outlined within SOP 7110-04020 (Surface Soil Sampling).
- Complete the test pit log and test pit profile log to provide description and location information for each sample collected.

#### **4.4.2 Excavated Soil Pile Sampling**

This method is considered favorable for soil logging and headspace VOC testing in the field. It is, however, generally considered unsuitable for collection of samples for laboratory analytical testing for

the simple reason that it is difficult to determine the exact position in the test pit/trench from which the sample was obtained.

Sampling from the soil pile is recommended if single or composite soil samples are required for general soil quality testing or when larger quantities of soil are needed for testing. Soil pile sampling is accomplished following the same methods specified in SOP 7110-04020.

#### **4.4.3 Backhoe Bucket Sampling**

Sampling from the backhoe bucket is an improvement on soil pile sampling in that the geologist or engineer is reasonably sure of the position where the soil was obtained. Backhoe bucket sampling is considered suitable for soil logging and headspace VOC testing; however, it is generally considered to be unsuitable for analytical testing. Sampling from the backhoe bucket may be considered suitable for analytical testing if, for instance, the base of the test pit is covered with water and use of standard sampling equipment has been unsuccessful in retrieving an acceptable sample.

Backhoe bucket sampling is accomplished following the same methods specified in SOP 7110-04020. If analytical testing is the objective, however, certain precautions must be taken. The bucket must be free of rust, grease, and paint. Some care is required to obtain a sample that has been minimally disturbed. For example, if a cohesive block of soil is present within the bucket, the soil sample should be retrieved from within the block of soil as much as possible. Only soil that has not been in contact with the backhoe bucket should be collected for analytical testing.

#### **4.4.4 General Sampling Procedures**

Representative samples shall be collected for laboratory analysis by the project geologist/engineer using the appropriate equipment.

Sample bottling, handling and transport shall be conducted in accordance with the requirements of the project specific QAPP.

Specific procedures pertaining to the handling and shipment of samples can be found in ENSR SOP 7510-04020 (Packaging and Shipment of Environmental Samples).

#### **4.5 Backfilling**

Prior to backfilling, all collected information will be reviewed to ensure that all the appropriate and/or required logs, photographs, measurements, and samples have been collected.

After review of the records, backfilling and compaction of test pit/trenches will be accomplished according to contract specifications. If excavation sidewalls have been undermined, the excavation may require temporary expansion to backfill properly.

All test pits/trenches will be backfilled to original grade unless otherwise specified.

It should be noted that project-specific requirements may include the use of clean backfill material. The requirements for clean backfill and the potential requirements for disposal of excavated soils should be defined within the project-specific plan.

## 5.0 QUALITY CONTROL

Quality control requirements for sample collection are dependent on project-specific sampling objectives. The QAPP will provide requirements for sample preservation and holding times, container types, sample packaging and shipment, as well as requirements for the collection of various quality assurance samples such as trip blanks, field blanks, equipment blanks, and field duplicate samples.

## 6.0 DOCUMENTATION

Test pit locations shall be referenced on the site map. Sample locations shall be referenced on a plan view/vertical section of each test pit/trench.

Photographs of specific geologic features may be required for documentation purposes. A scale or an item providing a size perspective shall be placed in each photograph. Frame number/picture location shall also be documented in the field logbook.

The following records will be maintained:

- Test Pit Log (Figure 1) and/or Test Pit Profile Log (Figure 2)
- Sample collection records
- Field logbook
- Chain-of-custody forms
- Shipping receipts

All documentation will be placed in the project files and retained following completion of the project.

## 7.0 TRAINING/QUALIFICATIONS

Test pit/trench subsurface explorations require a moderate degree of training and experience as numerous situations may occur that will require field decisions to be made. It is recommended that inexperienced personnel be supervised for several test pit/trench explorations before working on their own. Experienced excavation subcontractors are also of great assistance with problem resolution in the field. Field personnel should be health and safety certified as specified by the Occupational Safety and Health Administration [OSHA; 29 CFR 1910.120(e)(3)(i)] to work on sites where hazardous materials may be present.

## 8.0 REFERENCES

U.S. Environmental Protection Agency. Environmental Investigations Standard Operating Procedures and Quality Assurance Manual (EISOPQAM). USEPA, Region 4, Enforcement and Investigations Branch, Athens, GA. November 2001.

29 CFR Part 1926.650-652.



SOP NUMBER: 7230-04020

TEST PIT PROFILE LOG

|                   |               |
|-------------------|---------------|
| Project Number:   | Test Pit No.: |
| Project Name:     | Date:         |
| Project Location: | Inspector:    |

Field Sketch:

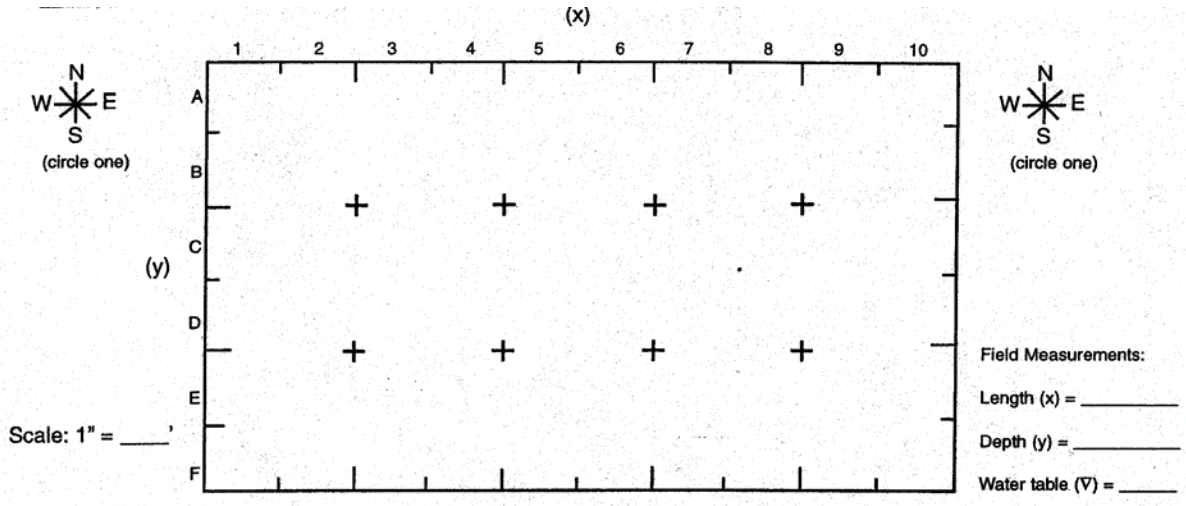

Sample Summary:

| Sample | Sample I.D. | Time | Depth( ft) | Hor. Loc. | Matrix | Misc. Information | PID |  |
|--------|-------------|------|------------|-----------|--------|-------------------|-----|--|
|        |             |      |            |           |        |                   |     |  |
| B      |             |      |            |           |        |                   |     |  |
| C      |             |      |            |           |        |                   |     |  |
| D      |             |      |            |           |        |                   |     |  |
| E      |             |      |            |           |        |                   |     |  |
| F      |             |      |            |           |        |                   |     |  |
| G      |             |      |            |           |        |                   |     |  |

**SOP NUMBER: 7315-04020**

**Operation/Calibration of HNU Photoionization Analyzer**

**Date:** September 22, 2006  
**Revision Number:** 3  
**Author:** Sally Bilodeau  
**Discipline:** Geosciences

**1.0 PURPOSE AND APPLICABILITY**

This document describes the procedures necessary for operation and calibration of the HNU Photoionization Analyzer. The HNU is primarily used by ENSR personnel for safety and survey monitoring of ambient air, determining the presence of volatiles in soil and water, and detecting leakage of volatiles.

Personnel responsible for using the HNU should first read and thoroughly familiarize themselves with the instrument instruction manual.

**1.1 Principle of Operation**

The HNU is a non-specific vapor/gas detector. The hand-held probe houses a photoionization detector (PID), consisting of an ultraviolet (UV) lamp and two electrodes, and a small fan that pulls ambient air into the probe inlet tube. All organic and inorganic vapor/gas compounds having ionization potentials (IPs) lower than the energy output of the UV lamp are ionized; and the resulting potentiometric change is seen as a needle deflection, proportional to vapor concentration, on the potentiometer of the readout/control box.

**1.2 Specifications**

|                               |  |
|-------------------------------|--|
| Detection range:*             | 0.1 to 2,000 ppm   |
| Linear range:*                | 0.1 to 400 ppm   |
| Response time:                | 3 seconds to 90% full scale deflection   |
| Operating temperature:        | -10°C to 40°C  |
| Operating time on battery,    | approximately 10 hours; at lower continuous use, without recorder: temperatures time is reduced. |
| Recharge from full discharge: | full recharge 12 to 14 hours   |

\*When equipped with 10.2 eV probe with SPAN set at 9.8 and measuring benzene. Values may vary for other compounds and conditions.

**1.3 Health and Safety Considerations**

Only photoionization analyzers stamped Division I Class I may be used in explosive atmospheres. Refer to the project Health & Safety plan for instructions pertaining to instrument use in explosive atmospheres.

## 2.0 RESPONSIBILITIES

### 2.1 Project Manager

It is the responsibility of the Project Manager to ensure that the necessary equipment is available and that field personnel are adequately trained in its use.

### 2.2 Field Operator

It is the responsibility of the field operator to calibrate and operate the HNU in accordance with the requirements of this procedure.

## 3.0 REQUIRED MATERIALS

- Calibration Gas: Compressed gas cylinder of isobutylene in air or similar stable gas mixture of known concentration. The selected gas should have an ionization potential similar to that of the vapors to be monitored, if known. The concentration should be at 50 to 75% of the range in which the instrument is to be calibrated.
- Regulator for calibration gas cylinder
- Approximately 3 to 4 feet of Teflon<sup>®</sup> tubing
- Pen or Sharpie<sup>™</sup>

## 4.0 METHOD

### 4.1 Preliminary Steps

- 4.1.1** Preliminary steps (battery charging, check-out, calibration, maintenance) should be conducted in a controlled or non-hazardous environment.
- 4.1.2** The sensor probe is carried separately in the instrument carrying case. For most safety and survey work, the 10.2 eV probe is used, as it detects more compounds than the 9.5 eV probe and is more durable than the 11.7 eV probe. Unclamp the cover from the readout/control box and remove the inner lid from the cover. Screw the inlet tube onto the sensor probe. Attach the probe cable plug to the 12 pin keyed socket on the readout panel by matching the alignment slot in the plug to the key in the connector and screwing down the probe connector until a distinct snap and lock is felt.
- 4.1.3** Turn the function switch to the BATT (battery check) position. The meter needle will deflect to the green zone if the battery is fully charged. If the needle is below the green arc or if the low battery indicator comes on, the battery must be recharged (Section 4.5) before the analyzer is used.



## 4.2 Operation

**4.2.1** Turn the function switch to the appropriate range. Check to see if the intake fan is functioning; if so, the probe will vibrate slightly and a distinct sound will be audible when holding the probe casing next to the ear. Also, verify that the UV lamp is on by briefly looking into the probe from a distance greater than 6 inches to observe a purple glow.

**WARNING:** Continued exposure to ultraviolet energy generated by the light source can be harmful to eyesight.

**4.2.2** At the beginning of each day, check the calibration (Section 4.3) and make adjustments if necessary. Record the calibration information in the field logbook.

**4.2.3** The instrument is now operational. Readings should be taken on the lowest possible scale and recorded in the field logbook.

**4.2.4** When the HNU is not being used or between monitoring intervals, the function switch should be set on the STANDBY position to conserve battery power and UV lamp life.

**4.2.5** At the end of each day, recheck calibration (Section 4.3) and record the information in the field logbook.

**4.2.6** To shutdown the HNU, turn the function switch to OFF.

**4.2.7** Recharge the battery after each use (Section 4.5).

**4.2.8** When transporting, disconnect the probe cable connector from the control panel and return the instrument to its stored condition.

## 4.3 Calibration Procedures

**4.3.1** For measurement on the 0 to 20 parts per million (ppm) or 0 to 200 ppm ranges only one calibration gas standard is required. Calibration on the 0 to 200 ppm range will provide accurate values on the 0 to 20 ppm range as well.

**4.3.2** Connect the probe tip to the gas cylinder regulator, observing safety precautions. A t-fitting and plastic tubing can be used to ensure that the gas is delivered to the probe at atmospheric pressure (Figure 1). Adjust the regulator so that the gas is delivered at 150 to 200 cubic centimeters per minute (cc/min). The fan inside the probe draws approximately 100 cc/min.

**4.3.3** Set the function switch to the proper range setting, based on the calibration gas used, and record the meter reading in the field logbook. Also record the calibration gas composition and concentration, the date, and the time.

- 4.3.4 If the adjustment is necessary, turn the span as required to read the ppm concentration of the gas standard, or the equivalent concentration of benzene if the HNU is being calibrated to benzene.
- 4.3.5 Recheck the zero setting. If readjustment of the zero setting is necessary, repeat the span adjustment. Record the span setting and the new meter reading. Whenever the span is changed, the zeroing procedure should be repeated.
- 4.3.6 If the calibration cannot be achieved or if the span setting resulting from calibration is 0.0, then the lamp must be cleaned (Section 4.4).
- 4.3.7 Alternate Calibration Technique: It may be more convenient in certain circumstances to employ the use of a Tedlar bag filled with calibration gas instead of a calibration cylinder. In that case, the bag (usually 3- to 10-liter capacity) should be filled with the appropriate calibration gas and brought to the HNU. The HNU probe should be connected to the discharge fitting on the bag using a piece of flexible tubing. Allow the HNU to draw the calibration gas from the bag and follow the instructions as indicated in Sections 4.3.3 and 4.3.4.

#### 4.4 Probe Cleaning

- 4.4.1 During periods of operation, moisture, dust, or other foreign matter can be drawn into the probe and form deposits on the surface of the UV lamp and ion chamber. This causes interference with the ionization process and produces erroneous readings. This condition is indicated by meter readings that are low, erratic, unstable, non-repeatable, or drifting. In most cases, the following field cleaning procedure is sufficient to correct this condition.
- 4.4.2 Turn the function switch to the OFF position. Disconnect the probe cable connector at the readout panel. Unscrew the probe inlet tube from the end cap and clean the inside of the tube making sure that the tube is dry and lint-free when finished. A pipe cleaner or a Kimwipe® and piece of wire can be used. Keeping the probe upright, remove the two screws holding the end clamp in place and remove the cap and ion chamber. Place one hand over the top of the lamp housing and tilt slightly. The light source will slide out of the housing. Take care not to lose or misplace o-rings or other parts. Do not touch the internal parts of the probe, particularly the UV lamp, with the bare hand during cleaning or reassembly. Surgical gloves are recommended. Clean the internal parts with a non-abrasive, lint-free paper towel (e.g., Kimwipe®) and reassemble the probe.

#### 4.5 Battery Charging

- 4.5.1 The battery charger is stored inside the instrument cover. To charge the battery, first insert the mini plug of the charger into the jack on the side of the meter with the function switch in the OFF position. Next, insert the charger plug into a 120VAC single phase, 50 to 60 Hz outlet.

- 4.5.2** To ensure that the charger is functioning, turn the function switch to BATT. The meter should deflect full scale. The sensor probe cable must be connected to the control panel for a battery check response. For normal battery charging, leave the function switch in the OFF position.
- 4.5.3** The battery is fully charged after 14 hours of charging. The charger can be left on indefinitely without damage. Disconnect the charger from the electrical outlet before disconnecting the mini plug from the instrument.

With the function switch turned to the appropriate range setting, the HNU may be operated while recharging.

#### **4.6 Troubleshooting Tips**

- 4.6.1** One convenient method for periodically confirming instrument response is to hold the sensor probe next to the tip of a magic marker. A significant needle deflection should be observed within 3 second with the function switch set at 0 to 20 ppm (after shave lotion or cologne will also make the needle deflect).
- 4.6.2** Air currents or drafts in the vicinity of the probe tip may cause fluctuations in readings.
- 4.6.3** A fogged or dirty lamp, due to operation in a humid or dusty environment, may cause erratic or fluctuating readings.
- 4.6.4** Moving the instrument from a cool or air-conditioned area to a warmer area may cause moisture to condense on the UV lamp and produce unstable readings.
- 4.6.5** A zero reading on the meter should not necessarily be interpreted as an absence of air contaminants. The detection capabilities of the HNU are limited to those compounds that will be ionized by the particular probe used.
- 4.6.6** Many volatile compounds have a low odor threshold. A lack of meter response in the presence of odors does not necessarily indicate instrument failure.
- 4.6.7** If a negative deflection of the HNU meter is noted, the ion chamber is dirty and needs cleaning. The chamber may be soaked in a solvent such as methanol, air dried, and then baked for 2 to 4 hours at a temperature of 100°C and not exceeding 105°C.
- 4.6.8** When high concentrations of hydrocarbons enter the ionization chamber in the HNU, a "quenching" effect takes place. Typically, it is noted by a sharp needle movement once the flow of gas is pierced by the HNU probe. Within 1 to 2 seconds the needle fades to zero point. To check whether or not the quenching effect is taking place, move the HNU probe to just outside the hole created in the foil. Get another reading

after 5 to 10 seconds. If quenching is taking place, a very erratic needle movement will occur. Once an operator has seen this phenomena, it is fairly easy to recognize.

## 5.0 QUALITY CONTROL

A calibration check of the HNU will be conducted once each day of sampling or whenever instrument operation is suspect. The HNU will sample a calibration gas of known concentration. The instrument must agree with the calibration gas within +/- 10.0%. If the instrument responds outside this tolerance, it must be recalibrated.

## 6.0 DOCUMENTATION

Safety and survey monitoring with the HNU will be documented in a bound field logbook and retained in the project files. The following information is to be recorded:

- Project name and number.
- Operator's signature.
- Date and time of operation.
- Calibration gas used.
- Calibration check at beginning and end of day (meter readings before adjustment).
- Span setting after calibration adjustment.
- Meter readings (monitoring data obtained).
- Instances of erratic or questionable meter readings and corrective actions taken.
- Instrument response verifications – magic marker (Section 4.6.1) or similar test.

## 7.0 REFERENCES

Not applicable.

**Figure 1**  
**PID Calibration Apparatus**

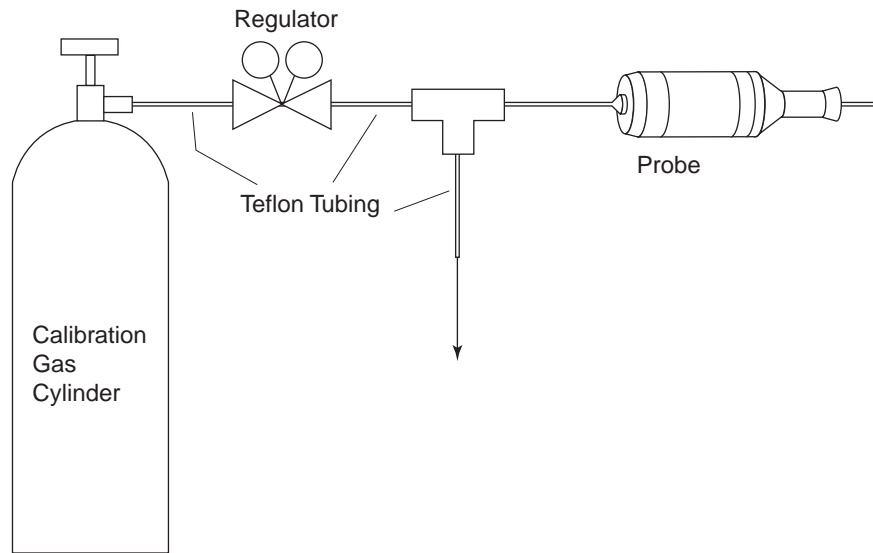

**SOP NUMBER: 7510-04020**

**Packaging and Shipment of Environmental Samples**

**Date:** September 22, 2006  
**Revision Number:** 4  
**Author:** Sally Bilodeau  
**Discipline:** Geosciences

**1.0 PURPOSE AND APPLICABILITY**

**1.1 Purpose and Applicability**

This Standard Operating Procedure (SOP) describes the procedures associated with the packaging and shipment of environmental samples. Two general categories of samples exist: environmental samples consisting of water and soil submitted for routine environmental testing, and waste material samples that include non-hazardous solid wastes and/or hazardous wastes as defined by 40 CFR Part 261 submitted for environmental testing or bench/pilot-scale treatability testing. Packaging and shipping procedures will differ for the two sample categories.

This SOP is applicable to packaging and shipment of environmental samples submitted for routine environmental testing. Although environmental samples are not considered a hazardous waste by definition, they may be considered hazardous materials. Department of Transportation (DOT) regulations regarding shipment of hazardous materials apply to samples that meet the DOT definition of hazardous material. Therefore, prior to shipping, samples must be evaluated by the shipper as to whether they should be shipped as hazardous or not. The shipper must determine and comply with the requirements for hazardous samples. Environmental samples also require fairly stringent packaging and shipping measures to ensure sample integrity as well as safety for those individuals handling and transporting the samples.

This SOP is designed to provide a high degree of certainty that environmental samples will arrive at their destination intact. This SOP assumes that samples will often require shipping overnight by a commercial carrier service; therefore, the procedures are more stringent than may be necessary if a laboratory courier is used or if samples are transported directly to their destination by a sampling team member. Should the latter occur, the procedures may be modified to reflect a lesser degree of packaging requirements.

Respective state or federal agency (regional offices) protocols may require or recommend specific types of equipment for use in sample packaging or a specific method of shipment that may vary from the indicated procedures. Deviations from this SOP to accommodate other regulatory requirements should be reviewed in advance of the field program, should be explained in the project work plan, and must be documented in the field project logbook when they occur.

## 1.2 General Principles

Sample packaging and shipment generally involves the placement of individual sample containers into a cooler or other similar shipping container and placement of packing materials and coolant in such a manner as to isolate the samples, maintain the required temperature, and to limit the potential for damage to sample containers when the cooler is transported.

## 1.3 Quality Assurance Planning Considerations

Sampling personnel should follow specific quality assurance guidelines as outlined in the site-specific work plan or Quality Assurance Project Plan (QAPP). Proper quality assurance requirements should be provided that will specify sample packaging and shipment requirements if variations to the indicated procedures are necessary on a particular project.

## 1.4 Health and Safety Considerations

Sampling personnel should be aware that packaging and shipment of samples involves potential physical hazards primarily associated with handling of occasional broken sample containers and lifting of heavy objects. Adequate health and safety measures must be taken to protect sampling personnel from these potential hazards. The project Health and Safety Plan (HASP) generally addresses physical and other potential hazards. This plan must be approved by the project Health and Safety Officer before work commences, must be distributed to all personnel performing sampling, and must be adhered to as field activities are performed.

## 2.0 RESPONSIBILITIES

### 2.1 Sampling Technician

It is the responsibility of the sampling technician to be familiar with the procedures outlined within this SOP and with specific sampling, quality assurance, and health and safety requirements outlined within the project-specific plans. The sampling technician is responsible for proper packaging and shipment of environmental samples and for proper documentation of sampling activities for the duration of the sampling program.

### 2.2 Sampling Coordinator

Large sampling programs may require additional support personnel such as a sampling coordinator. The sampling coordinator is responsible for providing management support such as maintaining an orderly sampling process, providing instructions to sampling technicians regarding sampling locations, and fulfilling sample documentation requirements, thereby allowing sampling technicians to collect samples in an efficient manner.

## 2.3 Project Manager

The project manager is responsible for ensuring that project-specific requirements are communicated to the project team and for providing the materials, resources, and guidance necessary to perform the activities in accordance with the project plan and this SOP. The project manager is also responsible for ensuring that proper arrangements have been made with the designated analytical laboratory. These arrangements include, but are not necessarily limited to, subcontractor agreements, analytical scheduling, and bottle/cooler orders. The project manager may delegate some of these responsibilities to other project staff.

## 3.0 REQUIRED MATERIALS

- Sample coolers
- Sample containers
- Shipping labels
- Chain-of-custody records, custody seals
- Bubble wrap
- Vermiculite (granular) or styrofoam pellets
- "Blue Ice" refreezable ice packs or ice cubes
- Transparent tape or rubber bands
- Fiber tape
- Duct tape
- Zipper-lock plastic bags
- Trash bags
- Health and Safety supplies
- Equipment decontamination materials
- Field project logbook/pen

## 4.0 METHOD

### 4.1 General Information

#### 4.1.1 Regulatory Information

The extent and nature of sample containerization will be governed by the type of sample, and the most reasonable projection of the sample's hazardous nature and constituents. The U.S. Environmental Protection Agency (EPA) regulations [40 CFR Section 261.4(d)] specify that samples of solid waste, water, soil, or air, collected for the sole purpose of testing, are exempt from regulation under the Resource



Conservation and Recovery Act (RCRA) when any of the following conditions are applicable:

- Samples are being transported to a laboratory for analysis;
- Samples are being transported to the collector from the laboratory after analysis;
- Samples are being stored (1) by the collector prior to shipment for analyses, (2) by the analytical laboratory prior to analyses, and (3) by the analytical laboratory after testing but prior to return of sample to the collector or pending the conclusion of a court case.

#### 4.1.2 Sample Information

The following information must accompany each shipment of samples on a chain-of-custody form (Figure 1) where each sample has an individual entry:

- Sample collector's name, mailing address, and telephone number;
- Analytical laboratory's name, mailing address, and telephone number;
- A unique identification of each sample;
- Sample description (matrix);
- Number and type of sample containers;
- Container size;
- Preservative;
- Type and method of analysis requested;
- Date and time that the samples were collected and prepared for shipping; and
- Special handling instructions, including notation of suspected high concentration samples.

#### 4.1.3 Laboratory Notifications

Prior to sample collection, the Project Manager or designated alternate must notify the laboratory manager of the number, type, and approximate collection and shipment dates for the samples. If the number, type, or date of sample shipment changes due to program changes that may occur in the field, the Project Manager or alternate must notify the laboratory of the changes. Additional notification from the field is often necessary when shipments are scheduled for weekend delivery.

## 4.2 General Site Preparation

### 4.2.1 Small Projects

Small projects of 1 or 2 days duration may require packaging and shipment of samples using the field vehicle as the sample preparation area. If sample coolers will be sent via third-party commercial carrier service, adequate sample packaging materials should be sent to the project location in advance of sampling or purchased from stores located near the site.

### 4.2.2 Large Projects

Multi-day or week sampling programs usually require rental of an office trailer or use of existing office/storage facilities for storage of equipment as well as for sample preparation. If possible, a designated area should be selected for storage of unused sample containers/coolers and another area for sample handling, packaging, and shipment. Handling of environmental samples should preferably be conducted in a clean area and away from unused sample containers to minimize the potential for cross contamination. Large quantities of packaging materials may require advance special ordering. Shipping forms/labels may be preprinted to facilitate shipping.

### 4.2.3 Cooler Inspection and Decontamination

Laboratories will often re-use coolers. Every cooler received at a project location should be inspected for condition and cleanliness. Any coolers that have cracked interior or exterior linings/panels or hinges should be discarded as their insulating properties are now compromised. Any coolers missing one or both handles should also be discarded if replacement handles (i.e., knotted rope handles) can not be fashioned in the field. Replacement coolers may be purchased in the field if necessary.

The interior and exterior of each cooler should be inspected for cleanliness before using it. Excess strapping tape and old shipping labels should be removed. If the cooler interior exhibits visible contamination or odors it should be decontaminated in accordance with ENSR SOP-7600-04020 (Decontamination of Field Equipment) prior to use. Drain plugs should be sealed on the inside with duct tape.

### 4.2.4 Other Considerations

**VOC Samples** – Sample containers used for volatile organic compound (VOC) analysis may be grouped into a single cooler, with a separate chain-of-custody record, to limit the number of trip blanks required for transportation and analysis. Individual VOC samples may also be placed into zipper-lock bags to further protect the samples.

**Contaminated Samples** – Sample containers with presumed high contaminant concentrations should be isolated within their own cooler with each sample container placed into a zipper-lock bag.

#### 4.3 Sample Packaging Method

Sample packaging should be conducted in the following manner:

- 4.3.1 Place plastic bubble wrap matting over the base of each cooler or shipping container as needed. A 2- to 3-inch thickness layer of vermiculite may be used as a substitute base material.
- 4.3.2 Insert a clean trash bag into the cooler to serve as a liner.
- 4.3.3 Check that each sample container is sealed, labeled legibly, and is externally clean. Re-label and/or wipe bottles clean if necessary. Clear tape should be placed over the labels to protect them. Wrap each sample bottle individually with bubble wrap secured with tape or rubber bands. Place bottles into the cooler in an upright single layer with approximately 1 inch of space between each bottle. Do not stack bottles or place them in the cooler lying on their side. If plastic and glass sample containers are used, alternate the placement of each type of container within the cooler so that glass bottles are not placed side by side.
- 4.3.4 Insert cooler temperature blanks if required.
- 4.3.5 Place additional vermiculite, bubble wrap, and/or styrofoam pellet packing material throughout the voids between sample containers within each cooler to a level that meets the approximate top of the sample containers. Packing material may require tamping by hand to reduce the potential for settling.
- 4.3.6 Place cubed ice or cold packs in heavy duty zipper-lock type plastic bags, close the bags, and distribute the packages in a layer over the top of the samples. Cubed ice should be double-bagged to prevent leakage. Loose ice should never be used. Cold packs should be used only if the samples are chilled before being placed in the cooler.
- 4.3.7 Add additional bubble wrap/styrofoam pellets or other packing materials to fill the balance of the cooler or container.
- 4.3.8 Obtain two pieces of chain of custody tape as shown in Figure 2 and enter the custody tape numbers in the appropriate place on the chain-of-custody form. Sign and date the chain-of-custody tape.
- 4.3.9 Complete the chain-of-custody form. If shipping the samples involves use of a third-party commercial carrier service, sign the chain-of-custody record thereby relinquishing custody of the samples. Shippers should not be asked to sign chain of

custody records. If a laboratory courier is used, or if samples are transported to the laboratory, the receiving party should accept custody and sign the chain-of-custody records. Remove the last copy from the form and retain it with other field notes. Place the original (with remaining copies) in a zipper-lock type plastic bag and tape the bag to the inside lid of the cooler or shipping container.

**4.3.10** Close the top or lid of the cooler or shipping container.

**4.3.11** If required for a specific project, place the chain-of-custody tape at two different locations (i.e., one tape on each side) on the cooler or container lid and overlap with transparent packaging tape (project-specific requirement).

**4.3.12** Packaging tape should be placed entirely around the sample shipment containers. A minimum of two full wraps of packaging tape will be placed at least two places on the cooler.

**4.3.13** Repeat the above steps for each cooler or shipping container.

#### **4.4 Sample Shipping Method**

Packaged sample coolers should be shipped using one of the following options:

##### **4.4.1 Hand Delivery**

When a project member is transporting samples by automobile to the laboratory, the cooler should only be sealed with tape. In these cases, chain of custody will be maintained by the person transporting the sample and chain-of-custody tape need not be used. Chain-of-custody records should be relinquished upon delivery and a copy of the record retained in the project file.

##### **4.4.2 Laboratory Courier**

Laboratory couriers are usually employees of the analytical laboratory receiving the samples. As such, they will accept custody of the samples and must be asked to sign the chain-of-custody records. Chain-of-custody records do not need to be sealed in the cooler, although it is recommended that the coolers be sealed with tape. All other packaging requirements generally apply unless otherwise specified in the QAPP.

If the laboratory courier is not authorized to accept custody of the samples, or if the requirements of the project plan preclude transfer to the laboratory courier, samples will be handled as described in Section 4.4.3.

#### 4.4.3 Third-Party Courier

If overnight shipment is required, a third party package delivery service should be used. Transport the cooler to the package delivery service office or arrange for package pick-up at the site. Fill out the appropriate shipping form or airbill and affix it to the cooler. Some courier services may use multi-package shipping forms where only one form needs to be filled out for all packages going to the same destination. If not, a separate shipping form should be used for each cooler. Keep the receipt for package tracking purposes should a package become lost. Please note that each cooler also requires a shipping label that indicates point of origin and destination. This will aid in recovery of a lost cooler if a shipping form gets misplaced. Never leave coolers unattended while waiting for package pick-up. Airbills or waybills will be maintained as part of the custody documentation.

#### 4.5 Sample Receipt

Upon receipt of the samples, the analytical laboratory will open the cooler or shipping container and will sign "received by laboratory" on each chain-of-custody form. The laboratory will verify that the chain-of-custody tape has not been broken previously and that the tape number corresponds with the number on the chain-of-custody record. The laboratory will note the condition of the samples upon receipt and will identify any discrepancies between the contents of the cooler and chain of custody. The analytical laboratory will then forward the back copy of the chain-of-custody record to the project manager to indicate that sample transmittal is complete.

### 5.0 QUALITY CONTROL

The potential for samples to break during transport increases greatly if individual containers are not snugly packed into the cooler. Completed coolers may be lightly shake-tested to check for any loose bottles. The cooler should be repacked if loose bottles are detected.

Environmental samples are generally shipped so that the samples are maintained at a temperature of approximately 4°C. Temperature blanks may be required for some projects as a quality assurance check on shipping temperature conditions. These blanks usually are supplied by the laboratory and consist of a 40-milliliter vial or plastic bottle filled with tap water. Temperature blanks should be placed near the center of the cooler.

### 6.0 DOCUMENTATION

Documentation supporting sample packaging and shipment generally consists of chain-of-custody records and shipping records. In addition, a description of sample packaging procedures will be written in the field project logbook. All documentation will be retained in the project files following project completion.

## 7.0 TRAINING/QUALIFICATIONS

Sample packaging and shipment is a relatively simple procedure requiring minimal training and a minimal amount of equipment. It is, however, recommended that initial attempts be supervised by more experienced personnel. Sampling technicians should be health and safety certified as specified by the Occupational Safety and Health Administration [OSHA; 29 CFR 1910.120(e)(3)(i)] to work on sites where hazardous waste materials are considered to be present.



**Figure 2. Chain of Custody Tape**  
(if required for a specific project)

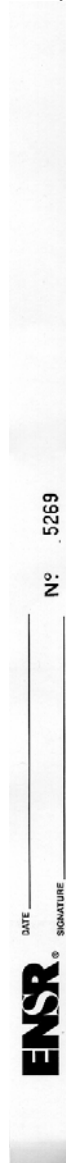



**SOP NUMBER: 7515-04020**

**Recording of Field Data**

**Date:** September 22, 2006  
**Revision Number:** 1  
**Author:** Sally Bilodeau  
**Discipline:** Quality Assurance

**1.0 INTRODUCTION**

**1.1 Purpose and Applicability**

This Standard Operating Procedure (SOP) provides instructions for recording data when documenting a sample collection event, field measurements, or a site visit. Field data may be recorded in field logbooks, on standardized forms, as annotated maps, as photo documentation, or electronically. Chain-of-custody records are also considered field data; however, these records are specifically addressed in SOPs 1007-04020 (Chain-of-Custody Procedures) and 7510 (Packaging and Shipping of Environmental Samples).

**1.2 Quality Assurance Planning Considerations**

Field records provide evidence and support for technical decisions, interpretations, and judgments. It is therefore critical that procedures and systems be in place to ensure that they are legible, identifiable and retrievable, and protected from loss or damage. In addition, client or regulatory requirements, or the end use of the data (e.g., to support litigation) may determine the format in which the data must be recorded. For example, some projects may require that all field information be recorded in the field logbook and may not allow the use of standardized forms. The requirements necessary to meet the data quality objectives for a particular project will be defined in the site-specific work plan and/or Quality Assurance Project Plan (QAPP) hereafter referred to as the project plan.

**1.3 Health and Safety Considerations**

Not applicable.

**2.0 RESPONSIBILITIES**

**2.1** The Project Manager is responsible for ensuring that project-specific requirements are communicated to the project team and for providing the materials, resources, and guidance necessary to perform the measurements in accordance with this SOP and the project plan. In the absence of a Field Team Leader, the Project Manager is responsible for ensuring that field records are reviewed and approved as described below.

**2.2** The Field Team Leader is responsible for reviewing and approving the field records for accuracy, completeness, and conformance to the procedures in this SOP.

**2.3** Field personnel are responsible for recording data according to the procedures outlined in this SOP.

### **3.0 REQUIRED MATERIALS**

The following materials are necessary for this procedure:

- Bound field logbook (preferably waterproof, such as Rite-in-Rain™)
- Standardized field data sheets (refer to individual SOPs for test pit logs, boring logs, groundwater sample collection logs, etc.)
- Pen or Sharpie™
- Watch or other time-keeping device

The following materials may also be needed:

- Site maps
- Clipboard
- Three-ring binder or equivalent
- Camera
- Hand-held electronic recording device (e.g., Personal Digital Assistant [PDA], laptop, or tablet PC)

### **4.0 METHOD**

#### **4.1 General**

- 4.1.1** Field activities vary widely, and no general rules can specify the exact information that must be recorded for each event. However, the field records must contain sufficient detail so that persons going to the site could reconstruct a particular situation without reliance on the collector's memory.
- 4.1.2** Field logbooks may be supplemented by standardized forms (e.g., well construction and development, sample collection forms, drum logs). In that case, the logbook provides a chronology of events, summary of personnel on site, and a narration of events not covered by the standardized forms. It is recommended that the details recorded on the standardized forms not be replicated in the logbook due to the potential for transcription errors and inconsistencies. References to standardized forms must be included in the logbook.
- 4.1.3** Entries will be recorded legibly in permanent ink (a black ballpoint pen is preferable) and will be signed and dated. No erasures or obliterations will be made. If an incorrect entry is made, the information will be crossed out with a single strike mark that is initialed and dated by the sampler, and the correct information added.
- 4.1.4** Pencil should not be used. If a ballpoint pen cannot be used because of adverse weather conditions (rain or freezing temperatures), a fine-point Sharpie™ is an

acceptable substitute. If conditions are such that only pencil can be used, an explanation must be included in the logbook and the affected data should be photocopied, signed as verified copy, and maintained in the project files as documentation that the data have not been changed.

- 4.1.5 Information to be recorded should address the questions of who, where, what, when, how, and why. A specific list of information that should be recorded is included in Table 1.
- 4.1.6 Entries will be objective, factual, and free of personal feelings or inappropriate language. Cryptic notes and undefined abbreviations or acronyms should be avoided.
- 4.1.7 Information will be made in as close to real time as possible. Information recorded significantly after the fact must be dated as such.

## 4.2 Field Logbooks

- 4.2.1 Field logbooks will be bound, water-proof, field survey books or notebooks with consecutively numbered pages.
- 4.2.2 Logbooks will be assigned to field personnel and will be identified by a unique document number. The logbook should be kept in the field person's possession or in a secure location during field activities and archived in the project files upon completion of the field program.
- 4.2.3 Logbooks should be specific to a project. Multiple projects should not be included in one logbook because of document retention and evidentiary reasons.
- 4.2.4 The title page of each logbook will contain the following:
  - Person to whom the logbook is assigned, ENSR office location, and phone number;
  - The logbook number;
  - Project name and number; and
  - Start and end dates of work covered by the logbook.
- 4.2.5 Logbook entries documenting sample collection or field measurements must clearly identify the task being completed (e.g., water level measurements, headspace readings). Units must be included for all measurements.
- 4.2.6 For ease of reference, it is recommended that a new page be started for each sampling day and that the time be recorded in the far left column. Each day's entries will be signed and dated by the person making the entries. A diagonal line across the bottom of the page will indicate the end of an entry.

### 4.3 Standardized Forms

- 4.3.1 At a minimum, each form must include a title identifying the activity being documented and the project identification (name and number).
- 4.3.2 Each form must be signed and dated by the person completing the form.
- 4.3.3 There should be no blank spaces on the form. Each space must be filled in with the information requested or "NA" (not applicable).
- 4.3.4 Forms should not be loose but should be maintained in an organized manner (e.g., clipboards, binders).

### 4.4 Maps and Drawings

- 4.4.1 Maps and drawings that document final sampling locations and that are separate from the field logbook must be referenced in the logbook. These maps or drawings must include the project name and number, site identification and location, and must be signed and dated by the person recording the locations.
- 4.4.2 Maps and drawings must include compass orientation and scale.

### 4.5 Photographs and Other Photo Documentation

- 4.5.1 Photo documentation, if permitted at the site, can provide invaluable information on site conditions, sample locations, and the sample itself.
- 4.5.2 Photographs, videos, or slides must be cross-referenced to entries in the field logbook or on a photo documentation log. Information to be recorded includes name of photographer, date, time, direction faced, description of subject, and sequential number of the photograph and roll number. An indication of scale is also helpful. Image-enhancing techniques (lenses, film) should also be noted.

### 4.6 Electronic Files

- 4.6.1 Electronically captured data may include data logging systems and hand-held electronic recording devices such as PDAs, laptops, or tablet PCs.
- 4.6.2 Field data that is captured electronically must be cross-referenced in the field logbook. Information to be recorded includes the identity of the person recording the data, instrument make and model number, measurement time and date, and file identification.
- 4.6.3 Sufficient backup systems must be in place to protect against the loss of data. Electronic files must be saved to a disk or backed up immediately upon completion. The backup disk or other media (CD, flash drive) should then be stored in a secure location separate from the laptop, tablet, or PDA.

- 4.6.4** Files must be uniquely identified and should be stored in the project files on the network. An unedited version of the file must be maintained and all subsequent manipulations tracked.

## **5.0 QUALITY CONTROL**

- 5.1** The field records will be reviewed by the Field Team Leader, or by the Project Manager or his/her designee, for accuracy, completeness, and adherence to the requirements of this SOP. At a minimum, this must occur at the end of the field event. For field activities of extended duration, it is recommended that this review occur more frequently (e.g., daily or weekly).
- 5.2** If information recorded in the field is transcribed to another format, the original record must be retained for comparison purposes.
- 5.3** Periodic photocopying of the field records should be considered to ensure against the loss or destruction of the original documents.

## **6.0 RECORDS MANAGEMENT**

At the end of the field program, original field records must be placed in the project files and maintained for a certain retention time. The duration of record retention will be determined by project-specific requirements or, in the absence of project requirements, by ENSR Corporate policy.

## **7.0 TRAINING/QUALIFICATIONS**

The individual recording field data must have read, and be familiar with, the requirements of this SOP.

## **8.0 REFERENCES**

USACE. 2001. Requirements for the Preparation of Sampling and Analysis Plans. EM 200-1-3. United States Army Corps of Engineers. 1 February 2001.

USEPA. 2004. Contract Laboratory Program Guidance for Field Samplers. OSWER 9240.0-35. EPA540-R-00-003. United States Environmental Protection Agency, Office of Superfund Remediation and Technology Innovation. August 2004.

USEPA. 2001. Environmental Investigations Standard Operating Procedures and Quality Assurance Manual. United States Environmental Protection Agency, Region 4, Athens, GA. November 2001.

USEPA. 1998. Test Methods for Evaluating Solid Wastes. Physical/Chemical Methods (SW-846). Third edition, including all final updates.

USEPA. 1992. RCRA Ground-water Monitoring: Draft Technical Guidance. United States Environmental Protection Agency, Office of Solid Waste, Washington, DC. November 1992.

**Table 1 Specific Information to be Recorded**

- Site name and location
- Personnel on site (ENSR, clients, site contacts, regulators, oversight personnel, subcontractors, general public)
- Results of phone calls, conversations
- Chronology of activities, including mobilization, investigatory activities, and demobilization
- Weather conditions (initial and any changes; temperature, barometric pressure, wind conditions, precipitation)
- Tidal stage (if applicable)
- Inspections of equipment, materials, supplies (problems, corrective action)
- Subcontractor name, description of services to be provided, and any issues (problems, stand by time)
- Description of major equipment (drill rigs, backhoe, survey vessels, sampling platforms)
- Field measurements
  - Description of procedure
  - Instruments (make, model, serial number, lamp)
  - Instrument calibration (date, time, personnel, standard, lot number, standard expiration date, true/measured results, units, corrective action, calibration checks and results)
  - Results (including units of measure, any correction factors applied, documentation of calculations (if applicable))
  - Date and time of measurement
  - Identity of person performing the measurements
  - Atmospheric conditions (if applicable)
- Equipment decontamination procedures and materials
- Well information (depth to water, static water depth, condition of well)
- Well purging information (procedure, equipment, volumes, pumping rate, criteria for acceptance, time and date)
- Presence and detection of immiscible layers, detection method, sampling method
- Sampling information
  - Procedures and equipment (type and material)
  - Sample (soil) selection criteria/rationale (PID, staining, water table)
  - Sample location identification (e.g., boring, well identification)
  - Sample location description (sketch, GPS coordinates, compass and distance measurements from fixed points)
  - Sample depth
  - Sample flow rate/drawdown
  - Sample description (recovery, moisture, color, odor, texture, turbidity, artifacts)
  - Sample manipulations (filtration, homogenization, compositing, preservation)
  - Sample date and time
  - Unique sample ID
  - Identity of sampler
  - Sample parameters, containers (size/type), preservation
  - QC samples (field duplicates, trip blanks, field/equipment blanks, MS/MSDs, split samples) – include ID, associated field sample, method of collection
- Any pertinent field observations that could affect data quality (instrument problems, contamination sources)
- Deviations from approved plan (schedule modifications, relocation or elimination of sample locations, change orders), including rationale
- Investigation-derived waste (IDW) types, volumes, storage, and disposal
- Health and safety (H&S) meetings, personal protective equipment (PPE) worn, H&S monitoring

**SOP NUMBER: 7600-04020**

## **Decontamination of Field Equipment**

**Date:** September 22, 2006  
**Revision Number:** 5  
**Author:** Sally Bilodeau  
**Discipline:** Geosciences

### **1.0 PURPOSE AND APPLICABILITY**

#### **1.1 Purpose and Applicability**

This standard operating procedure (SOP) describes the methods to be used for the decontamination of field equipment used in the collection of environmental samples. The list of field equipment may include a variety of items used in the collection of soil and/or water samples, such as split-spoon samplers, trowels, scoops, spoons, bailers, and pumps. Heavy equipment, such as drill rigs and backhoes, also requires decontamination, usually in a specially constructed temporary decontamination area.

Decontamination is performed as a quality assurance measure and a safety precaution. Improperly decontaminated sampling equipment can lead to misinterpretation of environmental data due to interference caused by cross-contamination. Decontamination protects field personnel from potential exposure to hazardous materials. Decontamination also protects the community by preventing transportation of contaminants from a site.

This SOP emphasizes decontamination procedures to be used for decontamination of reusable field equipment. Occasionally, dedicated field equipment such as well construction materials (well screen and riser pipe) or disposable field equipment (bailers or other general sampling implements) may also require decontamination prior to use. The project-specific work plan should indicate the specific decontamination requirements for a particular project.

Respective state or federal agency (regional offices) regulations may require specific types of equipment or procedures for use in decontamination of field equipment. The project manager should review the applicable regulatory requirements, if any, prior to the start of the field investigation program.

#### **1.2 General Principles**

Decontamination is accomplished by manually scrubbing, washing, or spraying equipment with detergent solutions, tap water, distilled/deionized water, steam and/or high pressure water, or solvents. The decontamination method and agents are generally determined on a project-specific basis and must be stated in the Quality Assurance Project Plan (QAPP).

Generally, decontamination of equipment is accomplished at each sampling site between collection points. Waste decontamination materials, such as spent liquids and solids, will be collected and managed as investigation-derived waste (IDW) for later disposal. All decontamination materials, including wastes, should be stored in a central location so as to

maintain control over the quantity of materials used or produced throughout the investigation program.

### **1.3 Quality Assurance Planning Considerations**

#### **1.3.1 General Considerations**

Sampling personnel should follow specific quality assurance guidelines as outlined in the site-specific QAPP. The QAPP guidelines typically require collection of equipment blank samples in order to determine the effectiveness of the decontamination procedure.

The decontamination method, solvent, frequency, location on site, and the method of containment and disposal of decontamination wash solids and solutions are dependent on site logistics, site-specific chemistry, and nature of the contaminated media to be studied and the objectives of the study. Each topic must be considered and addressed during development of a decontamination strategy and should be outlined in the QAPP.

#### **1.3.2 Solvent Selection**

There are several factors that need to be considered when deciding upon a decontamination solvent. The solvent should not be an analyte of interest. The sampling equipment must be resistant to the solvent. The solvent must be evaporative or water soluble or preferably both. The applicable regulatory agency may have specific requirements regarding decontamination solvents. The QAPP should specify the type of solvent to be used for a particular project.

The analytical objectives of the study must also be considered when deciding upon a decontamination solvent. Pesticide-grade methanol is the solvent of choice for general organic analyses. It is relatively safe and effective. Hexane, acetone, and isopropanol are sometimes used as well. A 10% nitric acid in deionized water solution is the solvent of choice for general metals analyses. Nitric acid can be used only on Teflon, plastics, and glass. If used on metal equipment, nitric acid will eventually corrode the metal and lead to the introduction of metals to the collected samples. Dilute hydrochloric acid is usually preferred over nitric acid when cleaning metal sampling equipment.

Equipment decontamination should be performed a safe distance away from the sampling area so as not to interfere with sampling activities but close enough to the sampling area to maintain an efficient working environment. If heavy equipment such as drill rigs or backhoes are to be decontaminated, then a central decontamination station should be constructed with access to a power source and water supply.



## 1.4 Health and Safety Considerations

Decontamination procedures may involve chemical exposure hazards associated with the type of contaminants encountered or solvents employed and may involve physical hazards associated with decontamination equipment. When decontamination is performed on equipment that has been in contact with hazardous materials or when the quality assurance objectives of the project require decontamination with chemical solvents, the measures necessary to protect personnel must be addressed in the project Health and Safety Plan (HASP). This plan must be approved by the project Health and Safety Officer before work commences, must be distributed to all personnel performing equipment decontamination, and must be adhered to as field activities are performed.

## 2.0 RESPONSIBILITIES

### 2.1 Sampling Technician

It is the responsibility of the sampling technician to be familiar with the decontamination procedures outlined within this SOP, and with specific quality assurance and health and safety requirements outlined within project-specific work plans (HASP, QAPP). The sampling technician is responsible for decontamination of field equipment and for proper documentation of decontamination activities. The sampling technician is also responsible for ensuring that decontamination procedures are followed by subcontractors when heavy equipment requires decontamination.

### 2.2 Field Project Manager

The field project manager is responsible for ensuring that the required decontamination procedures are followed at all times. The project manager is also responsible for ensuring that subcontractors construct and operate their decontamination facilities according to project specifications. The project manager is responsible for collection and control of IDW in accordance with project specifications.

## 3.0 REQUIRED MATERIALS

- Decontamination agents (per work plan requirements)
- Simple-green or other phosphate-free, perchlorate-free biodegradable detergent (note: ALCONOX may contain perchlorate so should not be used at the Tronox site.)
- Tap water
- Distilled/deionized water
- Nitric acid and/or hydrochloric acid
- Methanol and/or hexane, acetone, isopropanol
- Health and Safety equipment
- Chemical-free paper towels
- Waste storage containers: drums, 5-gallon pails with covers, plastic bags

- Cleaning containers: plastic buckets or tubs, galvanized steel pans, pump cleaning cylinder
- Cleaning brushes
- Pressure sprayers
- Squeeze bottles
- Plastic sheeting
- Aluminum foil
- Field project logbook/pen
- Personal protective equipment (as required by HASP)

## 4.0 METHODS

### 4.1 General Preparation

- 4.1.1** It should be assumed that all sampling equipment, even new items, are contaminated until the proper decontamination procedures have been performed on them or unless a certificate of analysis is available that demonstrates the item's cleanliness.

Field equipment that is not frequently used should be wrapped in aluminum foil, shiny side out, and stored in a designated "clean" area. Small field equipment can also be stored in plastic bags to eliminate the potential for contamination. Field equipment should be inspected and decontaminated prior to use if the equipment appears contaminated and/or has been stored for long periods of time. Unless customized procedures are stated in the QAPP for decontamination of equipment, the standard procedures specified in this SOP shall be followed.

- 4.1.2** Establish the decontamination station within an area that is convenient to the sampling location. If single samples will be collected from multiple locations, then a centralized decontamination station or a portable decontamination station should be established.
- 4.1.3** An IDW containment station should be established at this time also. The project-specific work plan should specify the requirements for IDW containment. In general, decontamination solutions are discarded as IDW between sampling locations. Solid waste is disposed of as it is generated.

### 4.2 Decontamination for Organic Analyses

- 4.2.1** This procedure applies to soil sampling and groundwater sampling equipment used in the collection of environmental samples submitted for organic constituents analysis. Examples of relevant items of equipment include split-spoons, trowels, scoops/spoons, bailers, and other small items. Submersible pump decontamination procedures are outlined in Section 4.4.

- 4.2.2 Decontamination is to be performed before sampling events and between sampling points.
- 4.2.3 After a sample has been collected, remove all gross contamination from the equipment or material by brushing and then rinsing with available tap water. This initial step may be completed using a 5-gallon pail filled with tap water. Steam or a high-pressure water rinse may also be conducted to remove solids and/or other contamination.
- 4.2.4 Wash the equipment with a phosphate-free detergent and tap water solution. This solution should be kept in a 5-gallon pail with its own brush.
- 4.2.5 Rinse with tap water or distilled/deionized water until all detergent and other residue is washed away. This step can be performed over an empty bucket using a squeeze bottle or pressure sprayer.
- 4.2.6 Rinse with methanol or other appropriate solvent using a squeeze bottle or pressure sprayer. Rinsate should be collected in a waste bucket.
- 4.2.7 Rerinse with deionized water to remove any residual solvent. Rinsate should be collected in the solvent waste bucket.
- 4.2.8 Allow the equipment to air-dry in a clean area or blot with chemical-free paper towels before reuse. Wrap the equipment in tin foil and/or seal it in a plastic bag if it will not be reused for a while.
- 4.2.9 Dispose of soiled materials and spent solutions in the designated IDW disposal containers.

#### **4.3 Decontamination for Inorganic (Metals) Analyses**

- 4.3.1 This procedure applies to soil sampling equipment used primarily in the collection of environmental samples submitted for inorganic constituents analysis. Examples of relevant items of equipment include split-spoons, trowels, scoops/spoons, bailers, and other small items.
- 4.3.2 For plastic and glass sampling equipment, follow the steps outlined in 4.2 above, however, use a 10% nitric acid solution (acid in water) in place of the solvent rinse in Section 4.2.6.
- 4.3.3 For metal sampling equipment, follow the steps outlined in 4.2 above, however, use a 10% hydrochloric acid solution (acid in water) in place of the solvent rinse in Section 4.2.6.

#### 4.4 Decontamination of Submersible Pumps

- 4.4.1** This procedure will be used to decontaminate submersible pumps before and between groundwater sample collection points. This procedure applies to both electric submersible and bladder pumps. This procedure also applies to discharge tubing if it will be reused between sampling points.
- 4.4.2** Prepare the decontamination area if pump decontamination will be conducted next to the sampling point. If decontamination will occur at another location, the pump and tubing may be removed from the well and placed into a clean trash bag for transport to the decontamination area. Pump decontamination is easier with the use of 3-foot tall pump cleaning cylinders (i.e., Nalgene cylinder) for the various cleaning solutions, although the standard bucket rinse equipment may be used.
- 4.4.3** Once the decontamination station is established, the pump should be removed from the well and the discharge tubing and power cord coiled by hand as the equipment is removed. If any of the equipment needs to be put down temporarily, place it on a plastic sheet (around well) or in a clean trash bag. If a disposable discharge line is used, it should be removed and discarded at this time.
- 4.4.4** As a first step in the decontamination procedure, use a pressure sprayer with tap water to rinse the exterior of the pump, discharge line, and power cord as necessary. Collect the rinsate and handle as IDW.
- 4.4.5** Place the pump into a pump-cleaning cylinder or bucket containing a detergent solution (detergent in tap water). Holding the tubing/power cord, pump solution through the pump system. A minimum of one gallon of detergent solution should be pumped through the system. Collect the rinsate and handle as IDW.
- 4.4.6** Place the pump into another cylinder/bucket containing a 10% solution of solvent (methanol or other designated solvent) in distilled/deionized water. Pump until the detergent solution is removed. Collect the rinsate and handle as IDW.
- 4.4.7** Place the pump into another cylinder/bucket containing distilled/deionized water. Pump a minimum of 3 to 5 pump system volumes (pump and tubing) of water through the system. Collect the rinsate and handle as IDW.
- 4.4.8** Remove the pump from the cylinder/bucket, and if the pump is reversible, place the pump in the reverse mode to discharge all removable water from the system. If the pump is not reversible, the pump and discharge line should be drained by hand as much as possible. Collect the rinsate and handle as IDW.
- 4.4.9** Using a pressure sprayer with distilled/deionized water, rinse the exterior of the pump, discharge line, and power cord thoroughly, shake all excess water, then place the pump system into a clean trash bag for storage. If the pump system will not be

used again right away, the pump itself should also be wrapped with aluminum foil before placing it into the bag.

#### **4.5 Decontamination of Large Equipment**

**4.5.1** Consult the QAPP for instruction on the location of the decontamination station and the method of containment of the wash solutions. On large projects, usually a temporary decontamination facility (decontamination pad) is required that may include a membrane-lined and bermed area large enough to drive heavy equipment (drill rig, backhoe) onto with enough space to spread other equipment and to contain overspray. Usually a small sump with pump is necessary to collect and contain rinsate. A water supply and power source is also necessary to run steam cleaning and/or pressure washing equipment.

**4.5.2** Upon arrival and prior to leaving a sampling site, all heavy equipment such as drill rigs, trucks, and backhoes should be thoroughly cleaned, and then the parts of the equipment that come in contact or in close proximity to sampling activity should be decontaminated. This can be accomplished in two ways, steam cleaning or high pressure water wash and manual scrubbing. Following this initial cleaning, only those parts of the equipment that come in close proximity to the sampling activities (i.e., auger stems, rods, backhoe bucket) must be decontaminated in between sampling events.

Occasionally, well construction materials such as well screen and riser pipe may require decontamination before the well materials are used. These materials may be washed in the decontamination pad, preferably on a raised surface above the pad (i.e., on sawhorses), with clean plastic draped over the work surfaces. Well materials usually do not require a multistep cleaning process as they generally arrive clean from the manufacturer. Usually, a thorough steam-cleaning of the interior/exterior of the well materials will be sufficient. The QAPP should provide specific guidance regarding decontamination of well materials.

### **5.0 QUALITY CONTROL**

#### **5.1 Field Blank Sample Collection**

General guidelines for quality control check of field equipment decontamination usually require the collection of one field blank from the decontaminated equipment per day. The QAPP should specify the type and frequency of collection of each type of quality assurance sample.

Field blanks are generally made by pouring laboratory-supplied deionized water into, over, or through the freshly decontaminated sampling equipment and then transferring this water into a sample container. Field blanks should then be labeled as a sample and submitted to the laboratory to be analyzed for the same parameters as the associated sample. Field blank

sample numbers, as well as collection method, time, and location, should be recorded in the field logbook.

## 6.0 DOCUMENTATION

Specific information regarding decontamination procedures should be documented in the project-specific field logbook. Documentation within the logbook should thoroughly describe the construction of each decontamination facility and the decontamination steps implemented in order to show compliance with the project work plan. Decontamination events should be logged when they occur with the following information documented:

- Date, time, and location of each decontamination event
- Equipment decontaminated
- Method
- Solvents
- Notable circumstances
- Identification of field blanks and decontamination rinsates
- Method of blank and rinsate collection
- Date, time, and location of blank and rinsate collection
- Disposition of IDW

Repetitive decontamination of small items of equipment does not need to be logged each time the item is cleaned.

## 7.0 TRAINING/QUALIFICATIONS

All sampling technicians performing decontamination must be properly trained in the decontamination procedures employed, the project data quality objectives, health and safety procedures, and the project quality assurance procedures. Specific training or orientation will be provided for each project to ensure that personnel understand the special circumstances and requirements of that project. Field personnel should be health and safety certified as specified by the Occupational Safety and Health Administration (OSHA; [29 CFR 1910.120(e)(3)(i)]) to work on sites where hazardous materials may be present.

## 8.0 REFERENCES

Not applicable.

SOP NUMBER: 7720-04020

## Hydraulic Conductivity Tests – Pressure Transducer Method

**Date:** September 22, 2006

**Revision Number:** 4

**Author:** Sally Bilodeau

**Discipline:** Water

### 1.0 PURPOSE AND APPLICABILITY

This Standard Operating Procedure (SOP) describes the procedures for conducting rising head and falling head hydraulic conductivity tests (slug tests). Rising head/falling head tests are performed to determine the hydraulic conductivity of the soil or rock surrounding a monitoring well.

#### 1.1 Hydraulic conductivity values are used for many purposes, including:

- to estimate rates of groundwater flow;
- to estimate responses of aquifers to applied stresses, such as pumping;
- to estimate the rate of movement of various chemicals in subsurface zones; and
- to construct and calibrate groundwater flow models.

In-situ tests to determine hydraulic conductivity can be conducted in open boreholes or in monitoring wells, and they can be variable-head tests or constant-head tests. The initial change in water levels required to begin the test can be produced by adding or removing a known volume of water using a pump or bailer, displacing water with a solid slug, or changing head conditions using pressurized gas. The water levels can be monitored using a water level tape or with a transducer. For the purpose of this SOP, the method to perform a variable-head test in a monitoring well using a slug and transducer is outlined. Use of other test options must be fully described in the project-specific work plan.

Wells that contain high concentrations of contaminants or non-aqueous phase liquids may require specialized equipment that will not be damaged by the contaminants. Slug tests should not be performed in wells with non-aqueous phase liquid present.

#### 1.2 General Principles

Hydraulic conductivity is a measure of the ability of a specific porous medium to transmit a specific fluid. Variable-head tests are performed by causing a sudden (instantaneous) rise or drop of the static water level in a well. Water levels are then monitored and recorded until the water level has returned to the condition prior to slug removal or insertion (i.e., static conditions) or sufficient data are collected to perform the hydraulic conductivity calculations.

#### 1.3 Definitions

**1.3.1 Hydraulic Conductivity:** The measure of the ability of a specific porous medium to transmit a specific fluid.

- 1.3.2 Slug:** Solid cylinder of Teflon, polyvinyl chloride (PVC), or other material that is either lowered into the water inside the well to produce a temporary rise in the water level or removed to produce a temporary fall in the water level. If the cylinder is not solid, it should be sealed to prevent water leaking into the slug.
- 1.3.3 Data Logger:** A data logger is a computerized device that records in electronic memory the hydrostatic pressure (i.e., water level) measured by the transducer at specific, user-defined time intervals. The data logger and transducer may be combined in one device.
- 1.3.4 Transducer:** A probe lowered into a well that measures hydrostatic pressure, which can be used to calculate the water level. The data logger and transducer may be combined in one device.
- 1.3.5 Falling Head Test:** Following the instantaneous rise in the static water level by inserting a slug, the drop in water level with respect to time is measured.
- 1.3.6 Rising Head Test:** Following the instantaneous lowering of the static water by extracting the slug, the rise of the water level with respect to time is measured.

#### **1.4 Quality Assurance Planning Considerations**

Personnel shall follow specific quality assurance guidelines as outlined in the site-specific work plan and/or Quality Assurance Project Plan (QAPP), hereafter referred to as the project plan. Proper quality assurance requirements shall be provided that will allow project objectives to be met. Quality assurance requirements typically require the collection of both the rising head and falling head data for comparison or performing the same test twice, although falling head tests may not be required for monitoring wells screened in a water table aquifer. The minimum initial change in well or borehole water level achieved by the slug should be a minimum of 1 foot to ensure that the formation is sufficiently stressed so that meaningful hydraulic conductivity values can be determined.

The data collected during slug tests shall be reviewed and analyzed by a hydrogeologist or similarly qualified personnel. Many factors affect the appropriate interpretation of slug test data.

#### **1.5 Health and Safety Considerations**

Hydraulic conductivity testing may involve chemical hazards associated with the potentially contaminated groundwater the testing equipment comes in contact with. Adequate health and safety measures must be taken to protect project personnel from potential chemical exposures or other hazards. The health and safety considerations for the site, including both potential physical and chemical hazards, shall be addressed in the site-specific Health and Safety Plan (HASP).



## 2.0 RESPONSIBILITIES

### 2.1 Field Technician

It is the responsibility of the field technician to be familiar with the general principles of hydraulic conductivity testing and the testing equipment. The field technician is responsible for verifying that the equipment is in proper operating condition prior to use and for implementing the measurement procedures in accordance with this SOP and the project plan.

### 2.2 Project Hydrogeologist

It is the responsibility of the project hydrogeologist to provide guidance to the field technician necessary to perform the measurements in accordance with this SOP and the project plan, and to perform and/or supervise the analysis of the data collected.

### 2.3 Project Manager

The project manager is responsible for ensuring that project-specific requirements are communicated to the project team and for providing the materials, resources, and guidance necessary to perform the measurements in accordance with this SOP and the project plan.

## 3.0 REQUIRED MATERIALS

- Well records (boring, well logs, and well construction diagrams), if available.
- Data logger(s).
- Transducer(s) with cable wire length sufficient to reach target depth and to reach from the well to the computer used to download data.
- Computer – with appropriate software and cables to download data from data logger.
- Slugs – diameter dependent upon well diameter; the slug length is dependent on the length of the water column in the well but should provide a minimum of 1 foot displacement of the water column; slug materials may be specified by the project plan.
- Nylon string.
- Water level meter or steel tape.
- Health and safety supplies.
- Equipment decontamination supplies – Liquinox, buckets, brushes, plastic sheeting (around well to keep equipment clean), solvent (e.g., methanol), deionized (DI) water, Kimwipes, and aluminum foil.
- Field logbook/standardized forms.
- Pen.

## 4.0 METHOD

### 4.1 Office Preparation

- 4.1.1 Review boring, well logs, and well construction diagrams to determine the geologic medium to be tested (sand, silt, clay, etc.) and well depth, depth-to-water, and screen placement.
- 4.1.2 Determine what slug diameter and length are to be used on the well. The larger the slug, the greater the water displacement, which results in more comprehensive data capture. The diameter of the well, the length of the water column, and the medium to be tested will determine which slug to use. The slug must be short enough to be completely submerged beneath the static water level, thin enough to be placed in the well and have sufficient room for the transducer cable, and there must be room beneath the bottom of the slug for the transducer.
- 4.1.3 Procure appropriate supplies based on well construction (transducer, cable length, slug sizes).

### 4.2 General Site Preparation

- 4.2.1 The monitoring wells to be tested should have been previously developed and had sufficient time to equilibrate before the hydraulic conductivity testing is conducted. The water level in tightly sealed wells may need to equilibrate once opened and exposed to the atmosphere. Well construction diagrams are necessary to determine the well diameter, sand pack thickness, the depth of the monitoring well, and the screened interval.
- 4.2.2 Measure the static water level and well depth in each well to be tested and record the level in the field logbook or on the standard form.
- 4.2.3 Confirm slug diameter and length to use in well. Record the slug length and diameter in the field logbook or on the standard form for use during data evaluation.
- 4.2.4 Record make and serial number of transducer and data logger in field logbook or on the standard form. If data logger saves to an electronic file, record specified file name in field logbook. File name protocols may be specified in the project plan.
- 4.2.5 Connect the transducer cable to the data logger, and program the logger in accordance with manufacturer's instructions. If using a device where the transducer and logger are combined in one unit, connect the unit to the computer and program it in accordance with manufacturer's instructions. A logarithmic time or very short time interval (typically 3 seconds or less) should be used for recording slug test data. The specified time interval should be outlined in the project plan, and the transducer should have sufficient memory to record data for the entire test duration.

- 4.2.6** Lower the transducer into the well. The transducer must be set at a level that will not be disturbed during the test, especially at the insertion or removal of the slug. Ideally, the entire slug length should be below the water surface; however, due to well geometry, this may not be possible. Also, if possible, the transducer should be set a few feet above the base of the well, above the level of any sediment that may be present and may potentially interfere with transducer readings. If these ideal conditions are not present, appropriate notes shall be recorded in the field logbook or on the standard form.
- 4.2.7** The cable of the transducer should be fixed (e.g., with tape or a clamp) at the top of the well to stabilize it and hold it in place.
- 4.2.8** Allow the water level to equilibrate to the static level (i.e., the water level observed prior to installing the transducer). Monitor with the transducer and/or the water level meter.
- 4.2.9** When the water has returned to the static water level following installation of the transducer, measure the depth to water using a water level meter and record in the field logbook or on the standard form. Also, measure and record an instantaneous pressure reading, if possible. This allows pressure readings to be tied to hydraulic head values. If the data logger requires input of a reference elevation, enter into the data logger an appropriate reference elevation that corresponds to the measured depth to water. Reference elevations may be set to zero, to the depth to water, or to a calculated hydraulic head (preferred). Record the reference elevation method in the field logbook or on the standard form.
- 4.2.10** Tie nylon string to the slug and cut it to a length that will allow the top of the slug to be submerged beneath the static water level. The length of the string should not allow the slug to touch the transducer.

### **4.3 Falling Head Test**

- 4.3.1** Lower the slug into the well so that the bottom of the slug is just above the water surface.
- 4.3.2** Start the data logger recording and immediately lower the slug into the water in the well. The data logger should record a few measurements of static water level in the few seconds it takes to lower the slug. Care should be taken to lower the slug fast enough to produce a nearly instantaneous rise in the water level, but not so fast as to produce a wave when the slug enters the water. The top of the slug should be below the static water level, completely submerged.
- 4.3.3** Monitor the data logger so that when the water level returns to the static level, the rising head test can be started (Section 4.4).

- 4.3.4** If the hydraulic conductivity is low, it may take hours or more for the water level to return to static. In this situation, the project hydrogeologist should determine a maximum duration for each test (typically 30 minutes).

#### **4.4 Rising Head Test**

- 4.4.1** When the falling head test is over, reset the data logger to begin a new test sequence. There should be no reason to re-set the reference elevation, unless the transducer moved during testing.
- 4.4.2** Start the data logger recording. The data logger should record a few measurements of static water level prior to removal of the slug. The slug should be removed quickly so that an instantaneous fall in the water level occurs. Take care not to disturb the transducer when removing the slug.
- 4.4.3** Terminate the rising head test when the water has returned to a static condition or the maximum test length duration determined by the project hydrogeologist has elapsed.
- 4.4.4** If the hydraulic conductivity is low, it may take hours or more for the water level to return to static. In this situation, the project hydrogeologist should determine a maximum duration for each test (typically 30 minutes).

#### **4.5 Data Review and Download**

- 4.5.1** Some data logging equipment allows collected data to be reviewed and plotted on a graph in the field. Prior to moving to the next well location, it is beneficial to review the collected data to see if it appears acceptable. Common problems are that a well was insufficiently stressed (i.e., water level change from static less than 1 foot) or the transducer moved. Contact the project hydrogeologist if uncertain on the acceptability of test results. If the data are not acceptable or the project plan requires it, the test should be repeated. Make appropriate notes in field logbook or on standard form.

The collected data from all tests must be downloaded into a computer for quantitative analysis. This may be performed in the field or in the office, but in the field is preferred. If renting equipment, do not return until the project hydrogeologist can preliminarily review downloaded data for completeness. Follow manufacturer's instructions.

#### **4.6 Equipment Decontamination**

All equipment that comes into contact with the groundwater (slugs, transducer, and water level tape) shall be decontaminated in accordance with the project plan before moving to the next location. The string, plastic sheeting, and any health and safety supplies (e.g., gloves) shall be properly disposed of in accordance with site requirements.

## 5.0 DATA ANALYSIS

Several methods are available for analyzing data obtained from hydraulic conductivity tests. Most methods incorporate graphical techniques, such as semi-log and log-log plots, to evaluate the data and select values for the calculations. Computer software is available to aid in evaluation.

Inherent in all analytical methods are simplifying assumptions concerning the aquifer properties and test methods. When selecting a particular analytical method, it is important to consider the basic assumptions that underlie the mathematical expressions. In many cases it may be advisable to evaluate the data using several methods and examine the range of hydraulic conductivities that are obtained. When reporting a calculated in-situ hydraulic conductivity, the analytical method(s) used should be referenced.

One of the major issues in determining the method to use is whether the aquifer is a water table (unconfined) aquifer or a confined aquifer. Falling head tests may overestimate hydraulic conductivity in water table aquifers if the screened interval is not fully submerged. Although the tests may be performed under such conditions and analyzed for comparative purposes to rising head tests, the limitations of falling head tests conducted in a water table aquifer should be appropriately considered and noted when reporting results or computing average values.

## 6.0 QUALITY CONTROL

The slug test and data analysis shall be performed under the supervision of a hydrogeologist or other qualified personnel. A hydrogeologist shall review all calculations and results.

Both rising and falling head tests or replicate tests may be conducted for quality control. If the rising and falling head results are not comparable, assess whether the transducer recorded accurate data. Knowledge of the boring logs is essential to assessing whether the measured response is consistent with the expected response. If not, the tests should be performed again.

The falling head test is not accurate for wells with screens that bracket the stabilized water table because it will overestimate hydraulic conductivity. These tests may be performed in water table wells, but the results should not be used quantitatively.

## 7.0 DOCUMENTATION

Documentation for the field component of hydraulic conductivity tests shall include a minimum of the following:

- Project and site identification
- Measured groundwater levels (with water level tape and/or electronic files from the data logger)
- Slug dimensions
- Data logger/transducer number or instrument identification number/model
- Reference elevations, if available

- Other data logger programming inputs
- Relevant dates and times for start/finish and subsequent water-level measurements
- Weather conditions
- Identities of personnel performing the measurements
- Description of any events or conditions that could impact the quality of the test results

The information shall be recorded in a field logbook or on a standard field form (see Figure 1). Analysis and results of the tests shall be documented in a technical memorandum and/or report as specified in the project plan.

## **8.0 TRAINING/QUALIFICATIONS**

The field technician shall be properly trained in the process of hydraulic conductivity measurement and shall have specialized training and supervision in using the transducer and data loggers.

The slug test and data analysis shall be performed by or under the supervision of a hydrogeologist or other qualified personnel. A hydrogeologist shall review all calculations and results.

Figure 1



Well ID: \_\_\_\_\_

**HYDRAULIC CONDUCTIVITY TEST LOG**

Client: \_\_\_\_\_ Date: \_\_\_\_\_ Time: Start \_\_\_\_\_ am/pm  
 Project No: \_\_\_\_\_ Finish \_\_\_\_\_ am/pm  
 Site Location: \_\_\_\_\_  
 Weather Conds: \_\_\_\_\_ Tester (s): \_\_\_\_\_

**1. WELL INFORMATION**

a. Ref. Point Elev. \_\_\_\_\_ e. Total Well Depth \_\_\_\_\_ i. Screen Length \_\_\_\_\_  
 b. Static Depth to GW \_\_\_\_\_ f. Gravel Pack Diameter \_\_\_\_\_ j. Geology of Screened Interval \_\_\_\_\_  
 c. Time of GW reading \_\_\_\_\_ g. Water Column Height \_\_\_\_\_ (e-b) \_\_\_\_\_  
 d. Static GW Elev.(Ho) \_\_\_\_\_ (a-b) h. Casing Diameter \_\_\_\_\_

**2. SLUG INFORMATION** (see back for volume calculation)

a. Slug Length \_\_\_\_\_  
 b. Slug Diameter \_\_\_\_\_

**3. DATA COLLECTION**

a. Method of Data Collection: Manual \_\_\_\_\_ Electronic \_\_\_\_\_  
 (see back)

b. Transducer Information  
 Make \_\_\_\_\_  
 Model \_\_\_\_\_  
 Serial Number \_\_\_\_\_  
 Offset \_\_\_\_\_  
 Linearity \_\_\_\_\_  
 Scale \_\_\_\_\_  
 Coefficient \_\_\_\_\_  
 Diameter/Length \_\_\_\_\_

c. Data Logging Information  
 Make \_\_\_\_\_  
 Model \_\_\_\_\_  
 Serial Number \_\_\_\_\_  
 Mode \_\_\_\_\_ (linear or logarithmic)  
 Ref. Point (designation) \_\_\_\_\_ (TOC, Ground Surface, actual el)  
 Ref. Point value (if elev.) \_\_\_\_\_  
 Positive numbers indicate increase or decrease in water level  
 (circle one)

**4. HYDRAULIC TEST INFORMATION**

| Start Time | Test Type (rising, falling) | Electronic File Name | Comments | End Time |
|------------|-----------------------------|----------------------|----------|----------|
| _____      | _____                       | _____                | _____    | _____    |
| _____      | _____                       | _____                | _____    | _____    |
| _____      | _____                       | _____                | _____    | _____    |

**5. MANUAL WATER LEVEL READINGS** (as needed for control)

| Time  | Location | Depth to Water | Time  | Location | Depth to Water |
|-------|----------|----------------|-------|----------|----------------|
| _____ | _____    | _____          | _____ | _____    | _____          |
| _____ | _____    | _____          | _____ | _____    | _____          |
| _____ | _____    | _____          | _____ | _____    | _____          |
| _____ | _____    | _____          | _____ | _____    | _____          |

Signature \_\_\_\_\_ Date \_\_\_\_\_

Q:\mw97\sops\7720\hydraulicconductivitytestlog.xls, page 1

