

Appendix A

LOU Roadmap

TABLE A-1. ROADMAP OF SITE SOIL AND SOIL GAS INVESTIGATIONS
Nevada Environmental Response Trust Site; Henderson, Nevada

| LOU | | Soil Investigations | | | | | | | | Soil Gas Investigations | | |
|-----|---|---------------------|----------------------|---|---|---|--------------------------|--------------------------|----------------------------|--|---|--|
| # | Name | IA | Parcel | Investigation Work Plan | Reporting of Results | HRA | RZ ^a | ECA | Soil Category ^b | Investigation Work Plan | Reporting of Results | HRA |
| 1 | Trade Effluent Settling Ponds | I | -- | 1) Phase B Source Area I WP (ENSR 2008b) <i>NDEP conditional approval: 5/6/08</i> 2) Revised Phase B WP Areas I-IV (AECOM 2009b) <i>NDEP approval: 1/16/09</i> 3) Scope for Additional Sampling Area I (Northgate 2009a) <i>NDEP approval: 11/24/09</i> 4) Pre-Confirmation WP (Northgate 2010e) <i>NDEP approval: 3/30/10</i> | 1) Revised DVSR Area I (Northgate 2010g,m) <i>NDEP approval: 1/20/10</i> 2) DVSR Shallow Supplemental Sampling Areas I and II (Neptune and Company 2010) <i>NDEP approval: 7/28/10</i> | HRA WP (Northgate 2010f) <i>NDEP approval: 3/16/10</i> | RZ-D | D3 | Category 1 | Phase B Soil Gas WP (ENSR 2008a) <i>NDEP approval: 3/08</i> | 1) Revised DVSR Soil Gas Survey (ENSR 2008f) <i>NDEP approval: 10/20/08</i> 2) Draft Report Soil Gas Survey Results (AECOM 2009a) | 1) HRA WP (Northgate 2010f) <i>NDEP Approval: 3/16/10</i> 2) Site-Wide Soil Gas HRA (Northgate 2010k) <i>Not reviewed by NDEP</i> |
| 2 | Open Area South of Trade Effluent Settling Ponds area | I | -- | 1) Phase B Source Area I WP (ENSR 2008b) <i>NDEP conditional approval: 5/6/08</i> 2) Revised Phase B WP Areas I-IV (AECOM 2009b) <i>NDEP approval: 1/16/09</i> 3) Scope for Additional Sampling Area I (Northgate 2009a) <i>NDEP approval: 11/24/09</i> 4) Pre-Confirmation WP (Northgate 2010e) <i>NDEP approval: 3/30/10</i> | 1) Revised DVSR Area I (Northgate 2010g,m) <i>NDEP approval: 1/20/10</i> 2) DVSR Shallow Supplemental Sampling Areas I and II (Neptune and Company 2010) <i>NDEP approval: 7/28/10</i> | HRA WP (Northgate 2010f) <i>NDEP approval: 3/16/10</i> | RZ-D | D3 | Category 1 | Phase B Soil Gas WP (ENSR 2008a) <i>NDEP approval: 3/08</i> | 1) Revised DVSR Soil Gas Survey (ENSR 2008f) <i>NDEP approval: 10/20/08</i> 2) Draft Report Soil Gas Survey Results (AECOM 2009a) | 1) HRA WP (Northgate 2010f) <i>NDEP Approval: 3/16/10</i> 2) Site-Wide Soil Gas HRA (Northgate 2010k) <i>Not reviewed by NDEP</i> |
| 3 | Air Pollution Emissions Associated with Industrial Processes | -- | N/A, throughout site | N/A, throughout site | N/A, throughout site | N/A, throughout site | N/A, throughout site | N/A, throughout site | N/A, throughout site | N/A, throughout site | N/A, throughout site | N/A, throughout site |
| 4 | Former Hardesty Chemical Company Site | IV | -- | 1) Phase B Source Area IV WP (ENSR 2008e) <i>NDEP conditional approval: 6/18/08</i> 2) Revised Phase B WP Areas I-IV (AECOM 2009b) <i>NDEP approval: 1/16/09</i> 3) Pre-Confirmation WP (Northgate 2010e) <i>NDEP approval: 3/30/10</i> | Revised DVSR Area IV (Northgate 2010c,h) <i>NDEP approval: 3/29/10</i> | HRA WP (Northgate 2010f) <i>NDEP approval: 3/16/10</i> | RZ-B | B4 | Category 1 | Phase B Soil Gas WP (ENSR 2008a) <i>NDEP approval: 3/08</i> | 1) Revised DVSR Soil Gas Survey (ENSR 2008f) <i>NDEP approval: 10/20/08</i> 2) Draft Report Soil Gas Survey Results (AECOM 2009a) | 1) HRA WP (Northgate 2010f) <i>NDEP Approval: 3/16/10</i> 2) Site-Wide Soil Gas HRA (Northgate 2010k) <i>Not reviewed by NDEP</i> |
| 5 | On-Site Portion of Beta Ditch Including the Small Diversion Ditch | II | -- | 1) Phase B Source Area II WP (ENSR 2008c) <i>NDEP conditional approval: 7/21/08</i> 2) Revised Phase B WP Areas I-IV (AECOM 2009b) <i>NDEP approval: 1/16/09</i> 3) Area II Supplemental Sampling (Northgate 2009b) <i>NDEP approval: 11/24/09</i> 4) Pre-Confirmation WP (Northgate 2010e) <i>NDEP approval: 3/30/10</i> | 1) DVSR Area II (Northgate 2010a) <i>NDEP approval: 2/18/10</i> 2) DVSR Shallow Supplemental Sampling Areas I and II (Neptune and Company 2010) <i>NDEP approval: 7/28/10</i> | HRA WP (Northgate 2010f) <i>NDEP approval: 3/16/10</i> | RZ-E | E2 | Category 1 | Phase B Soil Gas WP (ENSR 2008a) <i>NDEP approval: 3/08</i> | 1) Revised DVSR Soil Gas Survey (ENSR 2008f) <i>NDEP approval: 10/20/08</i> 2) Draft Report Soil Gas Survey Results (AECOM 2009a) | 1) HRA WP (Northgate 2010f) <i>NDEP Approval: 3/16/10</i> 2) Site-Wide Soil Gas HRA (Northgate 2010k) <i>Not reviewed by NDEP</i> |
| 6 | Unnamed Drainage Ditch Segment (BMI Landfill) | -- | -- | N/A, offsite common area | N/A, offsite common area | N/A, offsite common area | N/A, offsite common area | N/A, offsite common area | N/A, offsite common area | N/A, offsite common area | N/A, offsite common area | N/A, offsite common area |
| 7 | Old Pond P-2 and Associated Conveyance Facilities | II | -- | 1) Phase B Source Area II WP (ENSR 2008c) <i>NDEP conditional approval: 7/21/08</i> 2) Revised Phase B WP Areas I-IV (AECOM 2009b) <i>NDEP approval: 1/16/09</i> 3) Area II Supplemental Sampling (Northgate 2009b) <i>NDEP approval: 11/24/09</i> 4) Pre-Confirmation WP (Northgate 2010e) <i>NDEP approval: 3/30/10</i> | 1) DVSR Area II (Northgate 2010a) <i>NDEP approval: 2/18/10</i> 2) DVSR Shallow Supplemental Sampling Areas I and II (Neptune and Company 2010) <i>NDEP approval: 7/28/10</i> | HRA WP (Northgate 2010f) <i>NDEP approval: 3/16/10</i> | RZ-C | C9 | Category 1 | Phase B Soil Gas WP (ENSR 2008a) <i>NDEP approval: 3/08</i> | 1) Revised DVSR Soil Gas Survey (ENSR 2008f) <i>NDEP approval: 10/20/08</i> 2) Draft Report Soil Gas Survey Results (AECOM 2009a) | 1) HRA WP (Northgate 2010f) <i>NDEP Approval: 3/16/10</i> 2) Site-Wide Soil Gas HRA (Northgate 2010k) <i>Not reviewed by NDEP</i> |

TABLE A-1. ROADMAP OF SITE SOIL AND SOIL GAS INVESTIGATIONS
Nevada Environmental Response Trust Site; Henderson, Nevada

| LOU | | Soil Investigations | | | | | | | | Soil Gas Investigations | | |
|-----|---|---------------------|--------|---|---|---|-----------------|-----|----------------------------|--|---|--|
| # | Name | IA | Parcel | Investigation Work Plan | Reporting of Results | HRA | RZ ^a | ECA | Soil Category ^b | Investigation Work Plan | Reporting of Results | HRA |
| 8 | Old Pond P-3 and Associated Conveyance Facilities | II | -- | 1) Phase B Source Area II WP (ENSR 2008c) <i>NDEP conditional approval: 7/21/08</i> 2) Revised Phase B WP Areas I-IV (AECOM 2009b) <i>NDEP approval: 1/16/09</i> 3) Area II Supplemental Sampling (Northgate 2009b) <i>NDEP approval: 1/24/09</i> 4) Pre-Confirmation WP (Northgate 2010e) <i>NDEP approval: 3/30/10</i> | 1) DVSR Area II (Northgate 2010a) <i>NDEP approval: 2/18/10</i> 2) DVSR Shallow Supplemental Sampling Areas I and II (Neptune and Company 2010) <i>NDEP approval: 7/28/10</i> | HRA WP (Northgate 2010f) <i>NDEP approval: 3/16/10</i> | RZ-C | -- | Categories 2 and 3 | Phase B Soil Gas WP (ENSR 2008a) <i>NDEP approval: 3/08</i> | 1) Revised DVSR Soil Gas Survey (ENSR 2008f) <i>NDEP approval: 10/20/08</i> 2) Draft Report Soil Gas Survey Results (AECOM 2009a) | 1) HRA WP (Northgate 2010f) <i>NDEP Approval: 3/16/10</i> 2) Site-Wide Soil Gas HRA (Northgate 2010k) <i>Not reviewed by NDEP</i> |
| 9 | New Pond P- 2 and Associated Piping | II | -- | 1) Phase B Source Area II WP (ENSR 2008c) <i>NDEP conditional approval: 7/21/08</i> 2) Revised Phase B WP Areas I-IV (AECOM 2009b) <i>NDEP approval: 1/16/09</i> 3) Area II Supplemental Sampling (Northgate 2009b) <i>NDEP approval: 1/24/09</i> 4) Pre-Confirmation WP (Northgate 2010e) <i>NDEP approval: 3/30/10</i> | 1) DVSR Area II (Northgate 2010a) <i>NDEP approval: 2/18/10</i> 2) DVSR Shallow Supplemental Sampling Areas I and II (Neptune and Company 2010) <i>NDEP approval: 7/28/10</i> | HRA WP (Northgate 2010f) <i>NDEP approval: 3/16/10</i> | RZ-C | C10 | Category 1 | Phase B Soil Gas WP (ENSR 2008a) <i>NDEP approval: 3/08</i> | 1) Revised DVSR Soil Gas Survey (ENSR 2008f) <i>NDEP approval: 10/20/08</i> 2) Draft Report Soil Gas Survey Results (AECOM 2009a) | 1) HRA WP (Northgate 2010f) <i>NDEP Approval: 3/16/10</i> 2) Site-Wide Soil Gas HRA (Northgate 2010k) <i>Not reviewed by NDEP</i> |
| 10 | On-Site Hazardous Waste Landfill | I | -- | 1) Phase B Source Area I WP (ENSR 2008b) <i>NDEP conditional approval: 5/6/08</i> 2) Revised Phase B WP Areas I-IV (AECOM 2009b) <i>NDEP approval: 1/16/09</i> 3) Scope for Additional Sampling Area I (Northgate 2009a) <i>NDEP approval: 11/24/09</i> 4) Pre-Confirmation WP (Northgate 2010e) <i>NDEP approval: 3/30/10</i> | 1) Revised DVSR Area I (Northgate 2010g,m) <i>NDEP approval: 1/20/10</i> 2) DVSR Shallow Supplemental Sampling Areas I and II (Neptune and Company 2010) <i>NDEP approval: 7/28/10</i> | HRA WP (Northgate 2010f) <i>NDEP approval: 3/16/10</i> | RZ-D | -- | Category 2 | -- | -- | -- |
| 11 | Sodium Chlorate Filter Cake Holding Area | II | -- | 1) Phase B Source Area II WP (ENSR 2008c) <i>NDEP conditional approval: 7/21/08</i> 2) Revised Phase B WP Areas I-IV (AECOM 2009b) <i>NDEP approval: 1/16/09</i> 3) Area II Supplemental Sampling (Northgate 2009b) <i>NDEP approval: 1/24/09</i> 4) Pre-Confirmation WP (Northgate 2010e) <i>NDEP approval: 3/30/10</i> | 1) DVSR Area II (Northgate 2010a) <i>NDEP approval: 2/18/10</i> 2) DVSR Shallow Supplemental Sampling Areas I and II (Neptune and Company 2010) <i>NDEP approval: 7/28/10</i> | HRA WP (Northgate 2010f) <i>NDEP approval: 3/16/10</i> | RZ-B | B5 | Category 1 | -- | -- | -- |
| 12 | Hazardous Waste Storage Area | II | -- | 1) Phase B Source Area II WP (ENSR 2008c) <i>NDEP conditional approval: 7/21/08</i> 2) Revised Phase B WP Areas I-IV (AECOM 2009b) <i>NDEP approval: 1/16/09</i> 3) Area II Supplemental Sampling (Northgate 2009b) <i>NDEP approval: 1/24/09</i> 4) Pre-Confirmation WP (Northgate 2010e) <i>NDEP approval: 3/30/10</i> | 1) DVSR Area II (Northgate 2010a) <i>NDEP approval: 2/18/10</i> 2) DVSR Shallow Supplemental Sampling Areas I and II (Neptune and Company 2010) <i>NDEP approval: 7/28/10</i> | HRA WP (Northgate 2010f) <i>NDEP approval: 3/16/10</i> | RZ-B | B1 | Category 1 | Phase B Soil Gas WP (ENSR 2008a) <i>NDEP approval: 3/08</i> | 1) Revised DVSR Soil Gas Survey (ENSR 2008f) <i>NDEP approval: 10/20/08</i> 2) Draft Report Soil Gas Survey Results (AECOM 2009a) | 1) HRA WP (Northgate 2010f) <i>NDEP Approval: 3/16/10</i> 2) Site-Wide Soil Gas HRA (Northgate 2010k) <i>Not reviewed by NDEP</i> |
| 13 | Pond S-1 | II | -- | 1) Phase B Source Area II WP (ENSR 2008c) <i>NDEP conditional approval: 7/21/08</i> 2) Revised Phase B WP Areas I-IV (AECOM 2009b) <i>NDEP approval: 1/16/09</i> 3) Area II Supplemental Sampling (Northgate 2009b) <i>NDEP approval: 1/24/09</i> 4) Pre-Confirmation WP (Northgate 2010e) <i>NDEP approval: 3/30/10</i> | 1) DVSR Area II (Northgate 2010a) <i>NDEP approval: 2/18/10</i> 2) DVSR Shallow Supplemental Sampling Areas I and II (Neptune and Company 2010) <i>NDEP approval: 7/28/10</i> | HRA WP (Northgate 2010f) <i>NDEP approval: 3/16/10</i> | RZ-C | C11 | Category 1 | Phase B Soil Gas WP (ENSR 2008a) <i>NDEP approval: 3/08</i> | 1) Revised DVSR Soil Gas Survey (ENSR 2008f) <i>NDEP approval: 10/20/08</i> 2) Draft Report Soil Gas Survey Results (AECOM 2009a) | 1) HRA WP (Northgate 2010f) <i>NDEP Approval: 3/16/10</i> 2) Site-Wide Soil Gas HRA (Northgate 2010k) <i>Not reviewed by NDEP</i> |

TABLE A-1. ROADMAP OF SITE SOIL AND SOIL GAS INVESTIGATIONS
Nevada Environmental Response Trust Site; Henderson, Nevada

| LOU | | Soil Investigations | | | | | | | | Soil Gas Investigations | | |
|---------|--|---------------------|--------|---|--|---|-----------------|-----|----------------------------|--|---|--|
| # | Name | IA | Parcel | Investigation Work Plan | Reporting of Results | HRA | RZ ^a | ECA | Soil Category ^b | Investigation Work Plan | Reporting of Results | HRA |
| 14 | Pond P-1 and Associated Conveyance Piping | II | -- | 1) Phase B Source Area II WP (ENSR 2008c) <i>NDEP conditional approval: 7/21/08</i> 2) Revised Phase B WP Areas I-IV (AECOM 2009b) <i>NDEP approval: 1/16/09</i> 3) Area II Supplemental Sampling (Northgate 2009b) <i>NDEP approval: 1/24/09</i> 4) Pre-Confirmation WP (Northgate 2010e) <i>NDEP approval: 3/30/10</i> | 1) DVSR Area II (Northgate 2010a) <i>NDEP approval: 2/18/10</i> 2) DVSR Shallow Supplemental Sampling Areas I and II (Neptune and Company 2010) <i>NDEP approval: 7/28/10</i> | HRA WP (Northgate 2010f) <i>NDEP approval: 3/16/10</i> | RZ-C | C8 | Category 1 | Phase B Soil Gas WP (ENSR 2008a) <i>NDEP approval: 3/08</i> | 1) Revised DVSR Soil Gas Survey (ENSR 2008f) <i>NDEP approval: 10/20/08</i> 2) Draft Report Soil Gas Survey Results (AECOM 2009a) | 1) HRA WP (Northgate 2010f) <i>NDEP Approval: 3/16/10</i> 2) Site-Wide Soil Gas HRA (Northgate 2010k) <i>Not reviewed by NDEP</i> |
| 15 | Platinum Drying Unit | II | -- | 1) Phase B Source Area II WP (ENSR 2008c) <i>NDEP conditional approval: 7/21/08</i> 2) Revised Phase B WP Areas I-IV (AECOM 2009b) <i>NDEP approval: 1/16/09</i> 3) Area II Supplemental Sampling (Northgate 2009b) <i>NDEP approval: 1/24/09</i> 4) Pre-Confirmation WP (Northgate 2010e) <i>NDEP approval: 3/30/10</i> | 1) DVSR Area II (Northgate 2010a) <i>NDEP approval: 2/18/10</i> 2) DVSR Shallow Supplemental Sampling Areas I and II (Neptune and Company 2010) <i>NDEP approval: 7/28/10</i> | HRA WP (Northgate 2010f) <i>NDEP approval: 3/16/10</i> | RZ-B | -- | Category 2 | -- | -- | -- |
| 16 / 17 | Ponds AP-1, AP-2, and AP-3 and Associated Transfer Lines | II | -- | 1) Phase B Source Area II WP (ENSR 2008c) <i>NDEP conditional approval: 7/21/08</i> 2) Revised Phase B WP Areas I-IV (AECOM 2009b) <i>NDEP approval: 1/16/09</i> 3) Area II Supplemental Sampling (Northgate 2009b) <i>NDEP approval: 1/24/09</i> 4) Pre-Confirmation WP (Northgate 2010e) <i>NDEP approval: 3/30/10</i> | 1) DVSR Area II (Northgate 2010a) <i>NDEP approval: 2/18/10</i> 2) DVSR Shallow Supplemental Sampling Areas I and II (Neptune and Company 2010) <i>NDEP approval: 7/28/10</i> | HRA WP (Northgate 2010f) <i>NDEP approval: 3/16/10</i> | RZ-C | -- | Category 2 | Phase B Soil Gas WP (ENSR 2008a) <i>NDEP approval: 3/08</i> | 1) Revised DVSR Soil Gas Survey (ENSR 2008f) <i>NDEP approval: 10/20/08</i> 2) Draft Report Soil Gas Survey Results (AECOM 2009a) | 1) HRA WP (Northgate 2010f) <i>NDEP Approval: 3/16/10</i> 2) Site-Wide Soil Gas HRA (Northgate 2010k) <i>Not reviewed by NDEP</i> |
| 18 | Pond AP-4 | II | -- | 1) Phase B Source Area II WP (ENSR 2008c) <i>NDEP conditional approval: 7/21/08</i> 2) Revised Phase B WP Areas I-IV (AECOM 2009b) <i>NDEP approval: 1/16/09</i> 3) Area II Supplemental Sampling (Northgate 2009b) <i>NDEP approval: 1/24/09</i> 4) Pre-Confirmation WP (Northgate 2010e) <i>NDEP approval: 3/30/10</i> | 1) DVSR Area II (Northgate 2010a) <i>NDEP approval: 2/18/10</i> 2) DVSR Shallow Supplemental Sampling Areas I and II (Neptune and Company 2010) <i>NDEP approval: 7/28/10</i> | HRA WP (Northgate 2010f) <i>NDEP approval: 3/16/10</i> | RZ-C | -- | Category 3 | Phase B Soil Gas WP (ENSR 2008a) <i>NDEP approval: 3/08</i> | 1) Revised DVSR Soil Gas Survey (ENSR 2008f) <i>NDEP approval: 10/20/08</i> 2) Draft Report Soil Gas Survey Results (AECOM 2009a) | 1) HRA WP (Northgate 2010f) <i>NDEP Approval: 3/16/10</i> 2) Site-Wide Soil Gas HRA (Northgate 2010k) <i>Not reviewed by NDEP</i> |
| 19 | Ponds AP-5 & AP-6 | II | -- | 1) Phase B Source Area II WP (ENSR 2008c) <i>NDEP conditional approval: 7/21/08</i> 2) Revised Phase B WP Areas I-IV (AECOM 2009b) <i>NDEP approval: 1/16/09</i> 3) Area II Supplemental Sampling (Northgate 2009b) <i>NDEP approval: 1/24/09</i> 4) Pre-Confirmation WP (Northgate 2010e) <i>NDEP approval: 3/30/10</i> | 1) DVSR Area II (Northgate 2010a) <i>NDEP approval: 2/18/10</i> 2) DVSR Shallow Supplemental Sampling Areas I and II (Neptune and Company 2010) <i>NDEP approval: 7/28/10</i> | HRA WP (Northgate 2010f) <i>NDEP approval: 3/16/10</i> | RZ-D | D8 | Category 1 | -- | -- | -- |
| 20 | Pond C-1 and Associated Piping | II | -- | 1) Phase B Source Area II WP (ENSR 2008c) <i>NDEP conditional approval: 7/21/08</i> 2) Revised Phase B WP Areas I-IV (AECOM 2009b) <i>NDEP approval: 1/16/09</i> 3) Area II Supplemental Sampling (Northgate 2009b) <i>NDEP approval: 1/24/09</i> 4) Pre-Confirmation WP (Northgate 2010e) <i>NDEP approval: 3/30/10</i> | 1) DVSR Area II (Northgate 2010a) <i>NDEP approval: 2/18/10</i> 2) DVSR Shallow Supplemental Sampling Areas I and II (Neptune and Company 2010) <i>NDEP approval: 7/28/10</i> | HRA WP (Northgate 2010f) <i>NDEP approval: 3/16/10</i> | RZ-C RZ-E | -- | Category 2 | -- | -- | -- |

TABLE A-1. ROADMAP OF SITE SOIL AND SOIL GAS INVESTIGATIONS
Nevada Environmental Response Trust Site; Henderson, Nevada

| LOU | | Soil Investigations | | | | | | | | Soil Gas Investigations | | |
|-----|------------------------------------|---------------------|--------|---|---|---|-----------------|-----|----------------------------|-------------------------|----------------------|-----|
| # | Name | IA | Parcel | Investigation Work Plan | Reporting of Results | HRA | RZ ^a | ECA | Soil Category ^b | Investigation Work Plan | Reporting of Results | HRA |
| 20 | Associated Piping | III | -- | 1) Phase B Source Area III WP (ENSR 2008d) <i>NDEP conditional approval: 7/21/08</i> 2) Revised Phase B WP Areas I-IV (AECOM 2009b) <i>NDEP approval: 1/16/09</i> 3) Pre-Confirmation WP (Northgate 2010e) <i>NDEP approval: 3/30/10</i> | Revised DVSR Area III (Northgate 2010b,l) <i>NDEP approval: 3/17/10</i> | HRA WP (Northgate 2010f) <i>NDEP approval: 3/16/10</i> | RZ-B RZ-C | -- | Category 2 | -- | -- | -- |
| 21 | Pond Mn-1 and Associated Piping | III | -- | 1) Phase B Source Area III WP (ENSR 2008d) <i>NDEP conditional approval: 7/21/08</i> 2) Revised Phase B WP Areas I-IV (AECOM 2009b) <i>NDEP approval: 1/16/09</i> 3) Pre-Confirmation WP (Northgate 2010e) <i>NDEP approval: 3/30/10</i> | Revised DVSR Area III (Northgate 2010b,l) <i>NDEP approval: 3/17/10</i> | HRA WP (Northgate 2010f) <i>NDEP approval: 3/16/10</i> | RZ-C | C17 | Category 1 | -- | -- | -- |
| 22 | Pond WC-West and Associated Piping | I | -- | 1) Phase B Source Area I WP (ENSR 2008b) <i>NDEP conditional approval: 5/6/08</i> 2) Revised Phase B WP Areas I-IV (AECOM 2009b) <i>NDEP approval: 1/16/09</i> 3) Scope for Additional Sampling Area I (Northgate 2009a) <i>NDEP approval: 11/24/09</i> 4) Pre-Confirmation WP (Northgate 2010e) <i>NDEP approval: 3/30/10</i> | 1) Revised DVSR Area I (Northgate 2010g,m) <i>NDEP approval: 1/20/10</i> 2) DVSR Shallow Supplemental Sampling Areas I and II (Neptune and Company 2010) <i>NDEP approval: 7/28/10</i> | HRA WP (Northgate 2010f) <i>NDEP approval: 3/16/10</i> | RZ-D | D3 | Category 1 | -- | -- | -- |
| 22 | Pond WC-West and Associated Piping | II | -- | 1) Phase B Source Area II WP (ENSR 2008c) <i>NDEP conditional approval: 7/21/08</i> 2) Revised Phase B WP Areas I-IV (AECOM 2009b) <i>NDEP approval: 1/16/09</i> 3) Area II Supplemental Sampling (Northgate 2009b) <i>NDEP approval: 1/24/09</i> | 1) DVSR Area II (Northgate 2010a) <i>NDEP approval: 2/18/10</i> 2) DVSR Shallow Supplemental Sampling Areas I and II (Neptune and Company 2010) <i>NDEP approval: 7/28/10</i> | HRA WP (Northgate 2010f) <i>NDEP approval: 3/16/10</i> | RZ-C RZ-E | -- | Category 1 | -- | -- | -- |
| 22 | Pond WC-West and Associated Piping | III | -- | 1) Phase B Source Area III WP (ENSR 2008d) <i>NDEP conditional approval: 7/21/08</i> 2) Revised Phase B WP Areas I-IV (AECOM 2009b) <i>NDEP approval: 1/16/09</i> | Revised DVSR Area III (Northgate 2010b,l) <i>NDEP approval: 3/17/10</i> | HRA WP (Northgate 2010f) <i>NDEP approval: 3/16/10</i> | RZ-B RZ-C | -- | Category 1 | -- | -- | -- |
| 23 | Pond WC-East and Associated Piping | I | -- | 1) Phase B Source Area I WP (ENSR 2008b) <i>NDEP conditional approval: 5/6/08</i> 2) Revised Phase B WP Areas I-IV (AECOM 2009b) <i>NDEP approval: 1/16/09</i> 3) Scope for Additional Sampling Area I (Northgate 2009a) <i>NDEP approval: 11/24/09</i> 4) Pre-Confirmation WP (Northgate 2010e) <i>NDEP approval: 3/30/10</i> | 1) Revised DVSR Area I (Northgate 2010g,m) <i>NDEP approval: 1/20/10</i> 2) DVSR Shallow Supplemental Sampling Areas I and II (Neptune and Company 2010) <i>NDEP approval: 7/28/10</i> | HRA WP (Northgate 2010f) <i>NDEP approval: 3/16/10</i> | RZ-D | D3 | Category 1 | -- | -- | -- |
| 23 | Pond WC-East and Associated Piping | II | -- | 1) Phase B Source Area II WP (ENSR 2008c) <i>NDEP conditional approval: 7/21/08</i> 2) Revised Phase B WP Areas I-IV (AECOM 2009b) <i>NDEP approval: 1/16/09</i> 3) Area II Supplemental Sampling (Northgate 2009b) <i>NDEP approval: 1/24/09</i> | 1) DVSR Area II (Northgate 2010a) <i>NDEP approval: 2/18/10</i> 2) DVSR Shallow Supplemental Sampling Areas I and II (Neptune and Company 2010) <i>NDEP approval: 7/28/10</i> | HRA WP (Northgate 2010f) <i>NDEP approval: 3/16/10</i> | RZ-C RZ-E | -- | Category 1 | -- | -- | -- |
| 23 | Pond WC-East and Associated Piping | III | -- | 1) Phase B Source Area III WP (ENSR 2008d) <i>NDEP conditional approval: 7/21/08</i> 2) Revised Phase B WP Areas I-IV (AECOM 2009b) <i>NDEP approval: 1/16/09</i> | Revised DVSR Area III (Northgate 2010b,l) <i>NDEP approval: 3/17/10</i> | HRA WP (Northgate 2010f) <i>NDEP approval: 3/16/10</i> | RZ-B RZ-C | -- | Category 1 | -- | -- | -- |

TABLE A-1. ROADMAP OF SITE SOIL AND SOIL GAS INVESTIGATIONS
Nevada Environmental Response Trust Site; Henderson, Nevada

| LOU | | Soil Investigations | | | | | | | | Soil Gas Investigations | | |
|-----|---|---------------------|--------|---|--|---|-----------------|-----|----------------------------|--|---|--|
| # | Name | IA | Parcel | Investigation Work Plan | Reporting of Results | HRA | RZ ^a | ECA | Soil Category ^b | Investigation Work Plan | Reporting of Results | HRA |
| 24 | Leach Beds, Associated Conveyance Facilities and Former Manganese Tailings Area | III | -- | 1) Phase B Source Area III WP (ENSR 2008d) <i>NDEP conditional approval: 7/21/08</i> 2) Revised Phase B WP Areas I-IV (AECOM 2009b) <i>NDEP approval: 1/16/09</i> 3) Pre-Confirmation WP (Northgate 2010e) <i>NDEP approval: 3/30/10</i> | Revised DVSR Area III (Northgate 2010b,i) <i>NDEP approval: 3/17/10</i> | HRA WP (Northgate 2010f) <i>NDEP approval: 3/16/10</i> | RZ-C | C8 | Category 1 | Phase B Soil Gas WP (ENSR 2008a) <i>NDEP approval: 3/08</i> | 1) Revised DVSR Soil Gas Survey (ENSR 2008f) <i>NDEP approval: 10/20/08</i> 2) Draft Report Soil Gas Survey Results (AECOM 2009a) | 1) HRA WP (Northgate 2010f) <i>NDEP Approval: 3/16/10</i> 2) Site-Wide Soil Gas HRA (Northgate 2010k) <i>Not reviewed by NDEP</i> |
| 25 | Process Hardware Storage Area | IV | -- | 1) Phase B Source Area IV WP (ENSR 2008e) <i>NDEP conditional approval: 6/18/08</i> 2) Revised Phase B WP Areas I-IV (AECOM 2009b) <i>NDEP approval: 1/16/09</i> 3) Pre-Confirmation WP (Northgate 2010e) <i>NDEP approval: 3/30/10</i> | Revised DVSR Area IV (Northgate 2010c,h) <i>NDEP approval: 3/29/10</i> | HRA WP (Northgate 2010f) <i>NDEP approval: 3/16/10</i> | RZ-B | B1 | Category 1 | -- | -- | -- |
| 26 | Trash Storage Area | IV | -- | 1) Phase B Source Area IV WP (ENSR 2008e) <i>NDEP conditional approval: 6/18/08</i> 2) Revised Phase B WP Areas I-IV (AECOM 2009b) <i>NDEP approval: 1/16/09</i> 3) Pre-Confirmation WP (Northgate 2010e) <i>NDEP approval: 3/30/10</i> | Revised DVSR Area IV (Northgate 2010c,h) <i>NDEP approval: 3/29/10</i> | HRA WP (Northgate 2010f) <i>NDEP approval: 3/16/10</i> | RZ-B | B1 | Category 1 | -- | -- | -- |
| 27 | PCB Storage Area | IV | -- | 1) Phase B Source Area IV WP (ENSR 2008e) <i>NDEP conditional approval: 6/18/08</i> 2) Revised Phase B WP Areas I-IV (AECOM 2009b) <i>NDEP approval: 1/16/09</i> 3) Pre-Confirmation WP (Northgate 2010e) <i>NDEP approval: 3/30/10</i> | Revised DVSR Area IV (Northgate 2010c,h) <i>NDEP approval: 3/29/10</i> | HRA WP (Northgate 2010f) <i>NDEP approval: 3/16/10</i> | RZ-B | B1 | Category 1 | -- | -- | -- |
| 28 | Hazardous Waste Storage Area | IV | -- | 1) Phase B Source Area IV WP (ENSR 2008e) <i>NDEP conditional approval: 6/18/08</i> 2) Revised Phase B WP Areas I-IV (AECOM 2009b) <i>NDEP approval: 1/16/09</i> 3) Pre-Confirmation WP (Northgate 2010e) <i>NDEP approval: 3/30/10</i> | Revised DVSR Area IV (Northgate 2010c,h) <i>NDEP approval: 3/29/10</i> | HRA WP (Northgate 2010f) <i>NDEP approval: 3/16/10</i> | RZ-B | B4 | Category 1 | -- | -- | -- |
| 29 | Solid Waste Dumpsters | II | -- | 1) Phase B Source Area II WP (ENSR 2008c) <i>NDEP conditional approval: 7/21/08</i> 2) Revised Phase B WP Areas I-IV (AECOM 2009b) <i>NDEP approval: 1/16/09</i> 3) Area II Supplemental Sampling (Northgate 2009b) <i>NDEP approval: 1/24/09</i> 4) Pre-Confirmation WP (Northgate 2010e) <i>NDEP approval: 3/30/10</i> | 1) DVSR Area II (Northgate 2010a) <i>NDEP approval: 2/18/10</i> 2) DVSR Shallow Supplemental Sampling Areas I and II (Neptune and Company 2010) <i>NDEP approval: 7/28/10</i> | HRA WP (Northgate 2010f) <i>NDEP approval: 3/16/10</i> | RZ-B | -- | Category 2 | Phase B Soil Gas WP (ENSR 2008a) <i>NDEP approval: 3/08</i> | 1) Revised DVSR Soil Gas Survey (ENSR 2008f) <i>NDEP approval: 10/20/08</i> 2) Draft Report Soil Gas Survey Results (AECOM 2009a) | 1) HRA WP (Northgate 2010f) <i>NDEP Approval: 3/16/10</i> 2) Site-Wide Soil Gas HRA (Northgate 2010k) <i>Not reviewed by NDEP</i> |
| 30 | Ammonium Perchlorate Plant Area - Pad 35 | II | -- | 1) Phase B Source Area II WP (ENSR 2008c) <i>NDEP conditional approval: 7/21/08</i> 2) Revised Phase B WP Areas I-IV (AECOM 2009b) <i>NDEP approval: 1/16/09</i> 3) Area II Supplemental Sampling (Northgate 2009b) <i>NDEP approval: 1/24/09</i> 4) Pre-Confirmation WP (Northgate 2010e) <i>NDEP approval: 3/30/10</i> | 1) DVSR Area II (Northgate 2010a) <i>NDEP approval: 2/18/10</i> 2) DVSR Shallow Supplemental Sampling Areas I and II (Neptune and Company 2010) <i>NDEP approval: 7/28/10</i> | HRA WP (Northgate 2010f) <i>NDEP approval: 3/16/10</i> | RZ-D | D8 | Category 1 | -- | -- | -- |
| 31 | Drum Recycling Area | II | -- | 1) Phase B Source Area II WP (ENSR 2008c) <i>NDEP conditional approval: 7/21/08</i> 2) Revised Phase B WP Areas I-IV (AECOM 2009b) <i>NDEP approval: 1/16/09</i> 3) Area II Supplemental Sampling (Northgate 2009b) <i>NDEP approval: 1/24/09</i> 4) Pre-Confirmation WP (Northgate 2010e) <i>NDEP approval: 3/30/10</i> | 1) DVSR Area II (Northgate 2010a) <i>NDEP approval: 2/18/10</i> 2) DVSR Shallow Supplemental Sampling Areas I and II (Neptune and Company 2010) <i>NDEP approval: 7/28/10</i> | HRA WP (Northgate 2010f) <i>NDEP approval: 3/16/10</i> | RZ-D | D8 | Category 1 | -- | -- | -- |

TABLE A-1. ROADMAP OF SITE SOIL AND SOIL GAS INVESTIGATIONS
Nevada Environmental Response Trust Site; Henderson, Nevada

| LOU | | Soil Investigations | | | | | | | | Soil Gas Investigations | | |
|-----|--|---------------------|--------|---|---|--|------------------|-----|----------------------------|---|--|--|
| # | Name | IA | Parcel | Investigation Work Plan | Reporting of Results | HRA | RZ ^a | ECA | Soil Category ^b | Investigation Work Plan | Reporting of Results | HRA |
| 32 | Groundwater Remediation Unit | I | -- | 1) Phase B Source Area I WP (ENSR 2008b) NDEP conditional approval: 5/6/08 2) Revised Phase B WP Areas I-IV (AECOM 2009b) NDEP approval: 1/16/09 3) Scope for Additional Sampling Area I (Northgate 2009a) NDEP approval: 11/24/09 4) Pre-Confirmation WP (Northgate 2010e) NDEP approval: 3/30/10 | 1) Revised DVSR Area I (Northgate 2010g,m) NDEP approval: 1/20/10 2) DVSR Shallow Supplemental Sampling Areas I and II (Neptune and Company 2010) NDEP approval: 7/28/10 | HRA WP (Northgate 2010f) NDEP approval: 3/16/10 | RZ-D | D3 | Category 1 | -- | -- | -- |
| 33 | Sodium Perchlorate Platinum By-Product Filter | III | -- | 1) Phase B Source Area III WP (ENSR 2008d) NDEP conditional approval: 7/21/08 2) Revised Phase B WP Areas I-IV (AECOM 2009b) NDEP approval: 1/16/09 3) Pre-Confirmation WP (Northgate 2010e) NDEP approval: 3/30/10 | Revised DVSR Area III (Northgate 2010b,l) NDEP approval: 3/17/10 | HRA WP (Northgate 2010f) NDEP approval: 3/16/10 | RZ-B | B1 | Category 1 | -- | -- | -- |
| 34E | Former Manganese Tailings Area | III | -- | 1) Phase B Source Area III WP (ENSR 2008d) NDEP conditional approval: 7/21/08 2) Revised Phase B WP Areas I-IV (AECOM 2009b) NDEP approval: 1/16/09 | Revised DVSR Area III (Northgate 2010b,l) NDEP approval: 3/17/10 | HRA WP (Northgate 2010f) NDEP approval: 3/16/10 | N/A, active area | C18 | Category 1 | -- | -- | -- |
| 34W | Former Manganese Tailings Area | III | -- | 1) Phase B Source Area III WP (ENSR 2008d) NDEP conditional approval: 7/21/08 2) Revised Phase B WP Areas I-IV (AECOM 2009b) NDEP approval: 1/16/09 3) Pre-Confirmation WP (Northgate 2010e) NDEP approval: 3/30/10 | Revised DVSR Area III (Northgate 2010b,l) NDEP approval: 3/17/10 | HRA WP (Northgate 2010f) NDEP approval: 3/16/10 | RZ-C | C6 | Category 1 | -- | -- | -- |
| 35 | Truck Emptying/Dumping Site | I | -- | 1) Phase B Source Area I WP (ENSR 2008b) NDEP conditional approval: 5/6/08 2) Revised Phase B WP Areas I-IV (AECOM 2009b) NDEP approval: 1/16/09 3) Scope for Additional Sampling Area I (Northgate 2009a) NDEP approval: 11/24/09 4) Pre-Confirmation WP (Northgate 2010e) NDEP approval: 3/30/10 | 1) Revised DVSR Area I (Northgate 2010g,m) NDEP approval: 1/20/10 2) DVSR Shallow Supplemental Sampling Areas I and II (Neptune and Company 2010) NDEP approval: 7/28/10 | HRA WP (Northgate 2010f) NDEP approval: 3/16/10 | RZ-C | C1 | Category 1 | Phase B Soil Gas WP (ENSR 2008a) NDEP approval: 3/08 | 1) Revised DVSR Soil Gas Survey (ENSR 2008f) NDEP approval: 10/20/08 2) Draft Report Soil Gas Survey Results (AECOM 2009a) | 1) HRA WP (Northgate 2010f) NDEP Approval: 3/16/10 2) Site-Wide Soil Gas HRA (Northgate 2010k) Not reviewed by NDEP |
| 36 | Former Satellite Accumulation Point Unit 3, Maintenance Shop | II | -- | 1) Phase B Source Area II WP (ENSR 2008c) NDEP conditional approval: 7/21/08 2) Revised Phase B WP Areas I-IV (AECOM 2009b) NDEP approval: 1/16/09 3) Area II Supplemental Sampling (Northgate 2009b) NDEP approval: 1/24/09 4) Pre-Confirmation WP (Northgate 2010e) NDEP approval: 3/30/10 | 1) DVSR Area II (Northgate 2010a) NDEP approval: 2/18/10 2) DVSR Shallow Supplemental Sampling Areas I and II (Neptune and Company 2010) NDEP approval: 7/28/10 | HRA WP (Northgate 2010f) NDEP approval: 3/16/10 | RZ-B | B1 | Category 1 | -- | -- | -- |
| 37 | Former Satellite Accumulation Point Unit 3, Maintenance Shop | III | -- | 1) Phase B Source Area III WP (ENSR 2008d) NDEP conditional approval: 7/21/08 2) Revised Phase B WP Areas I-IV (AECOM 2009b) NDEP approval: 1/16/09 | Revised DVSR Area III (Northgate 2010b,l) NDEP approval: 3/17/10 | HRA WP (Northgate 2010f) NDEP approval: 3/16/10 | RZ-B | B1 | Category 1 | -- | -- | -- |
| 38 | Former Satellite Accumulation Point AP Change House & Laboratory | I | -- | 1) Phase B Source Area I WP (ENSR 2008b) NDEP conditional approval: 5/6/08 2) Revised Phase B WP Areas I-IV (AECOM 2009b) NDEP approval: 1/16/09 3) Scope for Additional Sampling Area I (Northgate 2009a) NDEP approval: 11/24/09 4) Pre-Confirmation WP (Northgate 2010e) NDEP approval: 3/30/10 | 1) Revised DVSR Area I (Northgate 2010g,m) NDEP approval: 1/20/10 2) DVSR Shallow Supplemental Sampling Areas I and II (Neptune and Company 2010) NDEP approval: 7/28/10 | HRA WP (Northgate 2010f) NDEP approval: 3/16/10 | RZ-C | -- | Category 2 | Phase B Soil Gas WP (ENSR 2008a) NDEP approval: 3/08 | 1) Revised DVSR Soil Gas Survey (ENSR 2008f) NDEP approval: 10/20/08 2) Draft Report Soil Gas Survey Results (AECOM 2009a) | 1) HRA WP (Northgate 2010f) NDEP Approval: 3/16/10 2) Site-Wide Soil Gas HRA (Northgate 2010k) Not reviewed by NDEP |

TABLE A-1. ROADMAP OF SITE SOIL AND SOIL GAS INVESTIGATIONS
Nevada Environmental Response Trust Site; Henderson, Nevada

| LOU | | Soil Investigations | | | | | | | | Soil Gas Investigations | | |
|-----|---|---------------------|--------|---|---|---|-----------------|-----|----------------------------|--|---|--|
| # | Name | IA | Parcel | Investigation Work Plan | Reporting of Results | HRA | RZ ^a | ECA | Soil Category ^b | Investigation Work Plan | Reporting of Results | HRA |
| 39 | Satellite Accumulation Point AP maintenance shop | I | -- | 1) Phase B Source Area I WP (ENSR 2008b) <i>NDEP conditional approval: 5/6/08</i> 2) Revised Phase B WP Areas I-IV (AECOM 2009b) <i>NDEP approval: 1/16/09</i> 3) Scope for Additional Sampling Area I (Northgate 2009a) <i>NDEP approval: 11/24/09</i> 4) Pre-Confirmation WP (Northgate 2010e) <i>NDEP approval: 3/30/10</i> | 1) Revised DVSR Area I (Northgate 2010g,m) <i>NDEP approval: 1/20/10</i> 2) DVSR Shallow Supplemental Sampling Areas I and II (Neptune and Company 2010) <i>NDEP approval: 7/28/10</i> | HRA WP (Northgate 2010f) <i>NDEP approval: 3/16/10</i> | RZ-C | -- | Category 2 | Phase B Soil Gas WP (ENSR 2008a) <i>NDEP approval: 3/08</i> | 1) Revised DVSR Soil Gas Survey (ENSR 2008f) <i>NDEP approval: 10/20/08</i> 2) Draft Report Soil Gas Survey Results (AECOM 2009a) | 1) HRA WP (Northgate 2010f) <i>NDEP Approval: 3/16/10</i> 2) Site-Wide Soil Gas HRA (Northgate 2010k) <i>Not reviewed by NDEP</i> |
| 40 | PCB Transformer Spill | III | -- | 1) Phase B Source Area III WP (ENSR 2008d) <i>NDEP conditional approval: 7/21/08</i> 2) Revised Phase B WP Areas I-IV (AECOM 2009b) <i>NDEP approval: 1/16/09</i> 3) Pre-Confirmation WP (Northgate 2010e) <i>NDEP approval: 3/30/10</i> | Revised DVSR Area III (Northgate 2010b,l) <i>NDEP approval: 3/17/10</i> | HRA WP (Northgate 2010f) <i>NDEP approval: 3/16/10</i> | RZ-B | B1 | Category 1 | -- | -- | -- |
| 41 | Unit 1 Tenants - Stains | IV | -- | 1) Phase B Source Area IV WP (ENSR 2008e) <i>NDEP conditional approval: 6/18/08</i> 2) Revised Phase B WP Areas I-IV (AECOM 2009b) <i>NDEP approval: 1/16/09</i> 3) Pre-Confirmation WP (Northgate 2010e) <i>NDEP approval: 3/30/10</i> | Revised DVSR Area IV (Northgate 2010c,h) <i>NDEP approval: 3/29/10</i> | HRA WP (Northgate 2010f) <i>NDEP approval: 3/16/10</i> | RZ-B | B1 | Category 1 | -- | -- | -- |
| 42 | Unit 2 Salt Conveyor | IV | -- | 1) Phase B Source Area IV WP (ENSR 2008e) <i>NDEP conditional approval: 6/18/08</i> 2) Revised Phase B WP Areas I-IV (AECOM 2009b) <i>NDEP approval: 1/16/09</i> 3) Pre-Confirmation WP (Northgate 2010e) <i>NDEP approval: 3/30/10</i> | Revised DVSR Area IV (Northgate 2010c,h) <i>NDEP approval: 3/29/10</i> | HRA WP (Northgate 2010f) <i>NDEP approval: 3/16/10</i> | RZ-B | B1 | Category 1 | Phase B Soil Gas WP (ENSR 2008a) <i>NDEP approval: 3/08</i> | 1) Revised DVSR Soil Gas Survey (ENSR 2008f) <i>NDEP approval: 10/20/08</i> 2) Draft Report Soil Gas Survey Results (AECOM 2009a) | 1) HRA WP (Northgate 2010f) <i>NDEP Approval: 3/16/10</i> 2) Site-Wide Soil Gas HRA (Northgate 2010k) <i>Not reviewed by NDEP</i> |
| 43 | Unit 4 and Old Sodium Chlorate Plant Decommissioning | II | -- | 1) Phase B Source Area II WP (ENSR 2008c) <i>NDEP conditional approval: 7/21/08</i> 2) Revised Phase B WP Areas I-IV (AECOM 2009b) <i>NDEP approval: 1/16/09</i> 3) Area II Supplemental Sampling (Northgate 2009b) <i>NDEP approval: 1/24/09</i> 4) Pre-Confirmation WP (Northgate 2010e) <i>NDEP approval: 3/30/10</i> | 1) DVSR Area II (Northgate 2010a) <i>NDEP approval: 2/18/10</i> 2) DVSR Shallow Supplemental Sampling Areas I and II (Neptune and Company 2010) <i>NDEP approval: 7/28/10</i> | HRA WP (Northgate 2010f) <i>NDEP approval: 3/16/10</i> | RZ-B | B6 | Category 1 | Phase B Soil Gas WP (ENSR 2008a) <i>NDEP approval: 3/08</i> | 1) Revised DVSR Soil Gas Survey (ENSR 2008f) <i>NDEP approval: 10/20/08</i> 2) Draft Report Soil Gas Survey Results (AECOM 2009a) | 1) HRA WP (Northgate 2010f) <i>NDEP Approval: 3/16/10</i> 2) Site-Wide Soil Gas HRA (Northgate 2010k) <i>Not reviewed by NDEP</i> |
| 44 | Unit 6 Basement | III | -- | 1) Phase B Source Area III WP (ENSR 2008d) <i>NDEP conditional approval: 7/21/08</i> 2) Revised Phase B WP Areas I-IV (AECOM 2009b) <i>NDEP approval: 1/16/09</i> 3) Pre-Confirmation WP (Northgate 2010e) <i>NDEP approval: 3/30/10</i> | Revised DVSR Area III (Northgate 2010b,l) <i>NDEP approval: 3/17/10</i> | HRA WP (Northgate 2010f) <i>NDEP approval: 3/16/10</i> | RZ-B | B1 | Category 1 | -- | -- | -- |
| 45 | Diesel Storage Tanks | II | -- | 1) Phase B Source Area II WP (ENSR 2008c) <i>NDEP conditional approval: 7/21/08</i> 2) Revised Phase B WP Areas I-IV (AECOM 2009b) <i>NDEP approval: 1/16/09</i> 3) Area II Supplemental Sampling (Northgate 2009b) <i>NDEP approval: 1/24/09</i> 4) Pre-Confirmation WP (Northgate 2010e) <i>NDEP approval: 3/30/10</i> | 1) DVSR Area II (Northgate 2010a) <i>NDEP approval: 2/18/10</i> 2) DVSR Shallow Supplemental Sampling Areas I and II (Neptune and Company 2010) <i>NDEP approval: 7/28/10</i> | HRA WP (Northgate 2010f) <i>NDEP approval: 3/16/10</i> | RZ-C | C5 | Category 1 | Phase B Soil Gas WP (ENSR 2008a) <i>NDEP approval: 3/08</i> | 1) Revised DVSR Soil Gas Survey (ENSR 2008f) <i>NDEP approval: 10/20/08</i> 2) Draft Report Soil Gas Survey Results (AECOM 2009a) | 1) HRA WP (Northgate 2010f) <i>NDEP Approval: 3/16/10</i> 2) Site-Wide Soil Gas HRA (Northgate 2010k) <i>Not reviewed by NDEP</i> |
| 46 | Former Old Main Cooling Tower and Recirculation Lines | III | -- | 1) Phase B Source Area III WP (ENSR 2008d) <i>NDEP conditional approval: 7/21/08</i> 2) Revised Phase B WP Areas I-IV (AECOM 2009b) <i>NDEP approval: 1/16/09</i> 3) Pre-Confirmation WP (Northgate 2010e) <i>NDEP approval: 3/30/10</i> | Revised DVSR Area III (Northgate 2010b,l) <i>NDEP approval: 3/17/10</i> | HRA WP (Northgate 2010f) <i>NDEP approval: 3/16/10</i> | RZ-C | -- | Category 2 | -- | -- | -- |

TABLE A-1. ROADMAP OF SITE SOIL AND SOIL GAS INVESTIGATIONS
Nevada Environmental Response Trust Site; Henderson, Nevada

| LOU | | Soil Investigations | | | | | | | | Soil Gas Investigations | | |
|-----|---|---------------------|--------|---|---|--|------------------|-----|----------------------------|---|--|--|
| # | Name | IA | Parcel | Investigation Work Plan | Reporting of Results | HRA | RZ ^a | ECA | Soil Category ^b | Investigation Work Plan | Reporting of Results | HRA |
| 47 | Leach Plant Area Manganese Ore Piles (current and historic) | III | -- | 1) Phase B Source Area III WP (ENSR 2008d) NDEP conditional approval: 7/21/08 2) Revised Phase B WP Areas I-IV (AECOM 2009b) NDEP approval: 1/16/09 | Revised DVSR Area III (Northgate 2010b,l) NDEP approval: 3/17/10 | HRA WP (Northgate 2010f) NDEP approval: 3/16/10 | N/A, active area | C18 | Category 1 | -- | -- | -- |
| 48 | Leach Plant Analyte Tanks | III | -- | 1) Phase B Source Area III WP (ENSR 2008d) NDEP conditional approval: 7/21/08 2) Revised Phase B WP Areas I-IV (AECOM 2009b) NDEP approval: 1/16/09 | Revised DVSR Area III (Northgate 2010b,l) NDEP approval: 3/17/10 | HRA WP (Northgate 2010f) NDEP approval: 3/16/10 | N/A, active area | C18 | Category 1 | -- | -- | -- |
| 49 | Leach Plant Area Sulfuric Acid Storage Tank | III | -- | 1) Phase B Source Area III WP (ENSR 2008d) NDEP conditional approval: 7/21/08 2) Revised Phase B WP Areas I-IV (AECOM 2009b) NDEP approval: 1/16/09 | Revised DVSR Area III (Northgate 2010b,l) NDEP approval: 3/17/10 | HRA WP (Northgate 2010f) NDEP approval: 3/16/10 | N/A, active area | C18 | Category 1 | -- | -- | -- |
| 50 | Leach Plant Area Leach Lines | III | -- | 1) Phase B Source Area III WP (ENSR 2008d) NDEP conditional approval: 7/21/08 2) Revised Phase B WP Areas I-IV (AECOM 2009b) NDEP approval: 1/16/09 | Revised DVSR Area III (Northgate 2010b,l) NDEP approval: 3/17/10 | HRA WP (Northgate 2010f) NDEP approval: 3/16/10 | N/A, active area | C18 | Category 1 | -- | -- | -- |
| 51 | Leach Plant Area Transfer Lines | III | -- | 1) Phase B Source Area III WP (ENSR 2008d) NDEP conditional approval: 7/21/08 2) Revised Phase B WP Areas I-IV (AECOM 2009b) NDEP approval: 1/16/09 3) Pre-Confirmation WP (Northgate 2010e) NDEP approval: 3/30/10 | Revised DVSR Area III (Northgate 2010b,l) NDEP approval: 3/17/10 | HRA WP (Northgate 2010f) NDEP approval: 3/16/10 | N/A, active area | C18 | Category 1 | -- | -- | -- |
| 52 | AP Plant Area Screening Building, Dryer Building, and Associated Sump | II | -- | 1) Phase B Source Area II WP (ENSR 2008c) NDEP conditional approval: 7/21/08 2) Revised Phase B WP Areas I-IV (AECOM 2009b) NDEP approval: 1/16/09 3) Area II Supplemental Sampling (Northgate 2009b) NDEP approval: 1/24/09 4) Pre-Confirmation WP (Northgate 2010e) NDEP approval: 3/30/10 | 1) DVSR Area II (Northgate 2010a) NDEP approval: 2/18/10 2) DVSR Shallow Supplemental Sampling Areas I and II (Neptune and Company 2010) NDEP approval: 7/28/10 | HRA WP (Northgate 2010f) NDEP approval: 3/16/10 | RZ-C | -- | Category 3 | -- | -- | -- |
| 53 | AP Plant Area Tank Farm | II | -- | 1) Phase B Source Area II WP (ENSR 2008c) NDEP conditional approval: 7/21/08 2) Revised Phase B WP Areas I-IV (AECOM 2009b) NDEP approval: 1/16/09 3) Area II Supplemental Sampling (Northgate 2009b) NDEP approval: 1/24/09 4) Pre-Confirmation WP (Northgate 2010e) NDEP approval: 3/30/10 | 1) DVSR Area II (Northgate 2010a) NDEP approval: 2/18/10 2) DVSR Shallow Supplemental Sampling Areas I and II (Neptune and Company 2010) NDEP approval: 7/28/10 | HRA WP (Northgate 2010f) NDEP approval: 3/16/10 | RZ-C | -- | Category 2 | -- | -- | -- |
| 54 | AP Plant Area Change House/Laboratory and Septic Tank | I | -- | 1) Phase B Source Area I WP (ENSR 2008b) NDEP conditional approval: 5/6/08 2) Revised Phase B WP Areas I-IV (AECOM 2009b) NDEP approval: 1/16/09 3) Scope for Additional Sampling Area I (Northgate 2009a) NDEP approval: 11/24/09 4) Pre-Confirmation WP (Northgate 2010e) NDEP approval: 3/30/10 | 1) Revised DVSR Area I (Northgate 2010g,m) NDEP approval: 1/20/10 2) DVSR Shallow Supplemental Sampling Areas I and II (Neptune and Company 2010) NDEP approval: 7/28/10 | HRA WP (Northgate 2010f) NDEP approval: 3/16/10 | RZ-C | -- | Category 2 | Phase B Soil Gas WP (ENSR 2008a) NDEP approval: 3/08 | 1) Revised DVSR Soil Gas Survey (ENSR 2008f) NDEP approval: 10/20/08 2) Draft Report Soil Gas Survey Results (AECOM 2009a) | 1) HRA WP (Northgate 2010f) NDEP Approval: 3/16/10 2) Site-Wide Soil Gas HRA (Northgate 2010k) Not reviewed by NDEP |

TABLE A-1. ROADMAP OF SITE SOIL AND SOIL GAS INVESTIGATIONS
Nevada Environmental Response Trust Site; Henderson, Nevada

| LOU | | Soil Investigations | | | | | | | | Soil Gas Investigations | | |
|-----|---|---------------------|--------|---|---|---|-----------------|----------------------|----------------------------|---|--|--|
| # | Name | IA | Parcel | Investigation Work Plan | Reporting of Results | HRA | RZ ^a | ECA | Soil Category ^b | Investigation Work Plan | Reporting of Results | HRA |
| 55 | Area Affected by July 1990 Fire | II | -- | 1) Phase B Source Area II WP (ENSR 2008c) NDEP conditional approval: 7/21/08 2) Revised Phase B WP Areas I-IV (AECOM 2009b) NDEP approval: 1/16/09 3) Area II Supplemental Sampling (Northgate 2009b) NDEP approval: 1/24/09 4) Pre-Confirmation WP (Northgate 2010e) NDEP approval: 3/30/10 | 1) DVSR Area II (Northgate 2010a) NDEP approval: 2/18/10 2) DVSR Shallow Supplemental Sampling Areas I and II (Neptune and Company 2010) NDEP approval: 7/28/10 | HRA WP (Northgate 2010f) NDEP approval: 3/16/10 | RZ-D | D7 | Category 1 | Phase B Soil Gas WP (ENSR 2008a) NDEP approval: 3/08 | 1) Revised DVSR Soil Gas Survey (ENSR 2008f) NDEP approval: 10/20/08 2) Draft Report Soil Gas Survey Results (AECOM 2009a) | 1) HRA WP (Northgate 2010f) NDEP Approval: 3/16/10 2) Site-Wide Soil Gas HRA (Northgate 2010k) Not reviewed by NDEP |
| 56 | AP Plant Area Old Building D-1 Washdown | II | -- | 1) Phase B Source Area II WP (ENSR 2008c) NDEP conditional approval: 7/21/08 2) Revised Phase B WP Areas I-IV (AECOM 2009b) NDEP approval: 1/16/09 3) Area II Supplemental Sampling (Northgate 2009b) NDEP approval: 1/24/09 4) Pre-Confirmation WP (Northgate 2010e) NDEP approval: 3/30/10 | 1) DVSR Area II (Northgate 2010a) NDEP approval: 2/18/10 2) DVSR Shallow Supplemental Sampling Areas I and II (Neptune and Company 2010) NDEP approval: 7/28/10 | HRA WP (Northgate 2010f) NDEP approval: 3/16/10 | RZ-D | D6 | Category 1 | -- | -- | -- |
| 57 | AP Plant Area Transfer Lines to Sodium Chlorate Process | II | -- | 1) Phase B Source Area II WP (ENSR 2008c) NDEP conditional approval: 7/21/08 2) Revised Phase B WP Areas I-IV (AECOM 2009b) NDEP approval: 1/16/09 3) Area II Supplemental Sampling (Northgate 2009b) NDEP approval: 1/24/09 4) Pre-Confirmation WP (Northgate 2010e) NDEP approval: 3/30/10 | 1) DVSR Area II (Northgate 2010a) NDEP approval: 2/18/10 2) DVSR Shallow Supplemental Sampling Areas I and II (Neptune and Company 2010) NDEP approval: 7/28/10 | HRA WP (Northgate 2010f) NDEP approval: 3/16/10 | RZ-D | D8 | Category 1 | -- | -- | -- |
| 58 | AP Plant Area New D-1 Building Washdown | I | -- | 1) Phase B Source Area I WP (ENSR 2008b) NDEP conditional approval: 5/6/08 2) Revised Phase B WP Areas I-IV (AECOM 2009b) NDEP approval: 1/16/09 3) Scope for Additional Sampling Area I (Northgate 2009a) NDEP approval: 11/24/09 4) Pre-Confirmation WP (Northgate 2010e) NDEP approval: 3/30/10 | 1) Revised DVSR Area I (Northgate 2010g,m) NDEP approval: 1/20/10 2) DVSR Shallow Supplemental Sampling Areas I and II (Neptune and Company 2010) NDEP approval: 7/28/10 | HRA WP (Northgate 2010f) NDEP approval: 3/16/10 | RZ-D | -- | Category 2 | Phase B Soil Gas WP (ENSR 2008a) NDEP approval: 3/08 | 1) Revised DVSR Soil Gas Survey (ENSR 2008f) NDEP approval: 10/20/08 2) Draft Report Soil Gas Survey Results (AECOM 2009a) | 1) HRA WP (Northgate 2010f) NDEP Approval: 3/16/10 2) Site-Wide Soil Gas HRA (Northgate 2010k) Not reviewed by NDEP |
| 59 | Storm Sewer System | II | -- | 1) Phase B Source Area II WP (ENSR 2008c) NDEP conditional approval: 7/21/08 2) Revised Phase B WP Areas I-IV (AECOM 2009b) NDEP approval: 1/16/09 3) Area II Supplemental Sampling (Northgate 2009b) NDEP approval: 1/24/09 | 1) DVSR Area II (Northgate 2010a) NDEP approval: 2/18/10 2) DVSR Shallow Supplemental Sampling Areas I and II (Neptune and Company 2010) NDEP approval: 7/28/10 | HRA WP (Northgate 2010f) NDEP approval: 3/16/10 | RZ-B RZ-C | N/A, throughout site | N/A, throughout site | -- | -- | -- |
| 59 | Storm Sewer System | III | -- | 1) Phase B Source Area III WP (ENSR 2008d) NDEP conditional approval: 7/21/08 2) Revised Phase B WP Areas I-IV (AECOM 2009b) NDEP approval: 1/16/09 | Revised DVSR Area III (Northgate 2010b,l) NDEP approval: 3/17/10 | HRA WP (Northgate 2010f) NDEP approval: 3/16/10 | RZ-B RZ-C | N/A, throughout site | N/A, throughout site | -- | -- | -- |
| 59 | Storm Sewer System | IV | -- | 1) Phase B Source Area IV WP (ENSR 2008e) NDEP conditional approval: 6/18/28 2) Revised Phase B WP Areas I-IV (AECOM 2009b) NDEP approval: 1/16/09 | Revised DVSR Area IV (Northgate 2010c,h) NDEP approval: 3/29/10 | 1) HRA WP (Northgate 2010f) NDEP approval: 3/16/10 2) Revised HRA for RZ-A (Northgate 2010d) NDEP approval 8/20/10 | RZ-A RZ-B | N/A, throughout site | N/A, throughout site | -- | -- | -- |

TABLE A-1. ROADMAP OF SITE SOIL AND SOIL GAS INVESTIGATIONS
Nevada Environmental Response Trust Site; Henderson, Nevada

| LOU | | Soil Investigations | | | | | | | | Soil Gas Investigations | | |
|-----------------|--|---------------------|--------|---|--|--|------------------------------|----------------------|----------------------------|---|--|--|
| # | Name | IA | Parcel | Investigation Work Plan | Reporting of Results | HRA | RZ ^a | ECA | Soil Category ^b | Investigation Work Plan | Reporting of Results | HRA |
| 60 | Acid Drain System | I | -- | 1) Phase B Source Area I WP (ENSR 2008b) NDEP conditional approval: 5/6/08 2) Revised Phase B WP Areas I-IV (AECOM 2009b) NDEP approval: 1/16/09 3) Scope for Additional Sampling Area I (Northgate 2009a) NDEP approval: 11/24/09 | 1) Revised DVSR Area I (Northgate 2010g,m) NDEP approval: 1/20/10 2) DVSR Shallow Supplemental Sampling Areas I and II (Neptune and Company 2010) NDEP approval: 7/28/10 | HRA WP (Northgate 2010f) NDEP approval: 3/16/10 | RZ-C RZ-D | N/A, throughout site | N/A, throughout site | Phase B Soil Gas WP (ENSR 2008a) NDEP approval: 3/08 | 1) Revised DVSR Soil Gas Survey (ENSR 2008f) NDEP approval: 10/20/08 2) Draft Report Soil Gas Survey Results (AECOM 2009a) | 1) HRA WP (Northgate 2010f) NDEP Approval: 3/16/10 2) Site-Wide Soil Gas HRA (Northgate 2010k) Not reviewed by NDEP |
| 60 | Acid Drain System | II | -- | 1) Phase B Source Area II WP (ENSR 2008c) NDEP conditional approval: 7/21/08 2) Revised Phase B WP Areas I-IV (AECOM 2009b) NDEP approval: 1/16/09 3) Area II Supplemental Sampling (Northgate 2009b) NDEP approval: 1/24/09 4) Pre-Confirmation WP (Northgate 2010e) NDEP approval: 3/30/10 | 1) DVSR Area II (Northgate 2010a) NDEP approval: 2/18/10 2) DVSR Shallow Supplemental Sampling Areas I and II (Neptune and Company 2010) NDEP approval: 7/28/10 | HRA WP (Northgate 2010f) NDEP approval: 3/16/10 | RZ-B RZ-C RZ-D RZ-D | N/A, throughout site | N/A, throughout site | Phase B Soil Gas WP (ENSR 2008a) NDEP approval: 3/08 | 1) Revised DVSR Soil Gas Survey (ENSR 2008f) NDEP approval: 10/20/08 2) Draft Report Soil Gas Survey Results (AECOM 2009a) | 1) HRA WP (Northgate 2010f) NDEP Approval: 3/16/10 2) Site-Wide Soil Gas HRA (Northgate 2010k) Not reviewed by NDEP |
| 60 | Acid Drain System | III | -- | 1) Phase B Source Area III WP (ENSR 2008d) NDEP conditional approval: 7/21/08 2) Revised Phase B WP Areas I-IV (AECOM 2009b) NDEP approval: 1/16/09 | Revised DVSR Area III (Northgate 2010b,l) NDEP approval: 3/17/10 | HRA WP (Northgate 2010f) NDEP approval: 3/16/10 | RZ-B RZ-C | N/A, throughout site | N/A, throughout site | Phase B Soil Gas WP (ENSR 2008a) NDEP approval: 3/08 | 1) Revised DVSR Soil Gas Survey (ENSR 2008f) NDEP approval: 10/20/08 2) Draft Report Soil Gas Survey Results (AECOM 2009a) | 1) HRA WP (Northgate 2010f) NDEP Approval: 3/16/10 2) Site-Wide Soil Gas HRA (Northgate 2010k) Not reviewed by NDEP |
| 60 ^c | Acid Drain System | IV | -- | 1) Phase B Source Area IV WP (ENSR 2008e) NDEP conditional approval: 6/18/28 2) Revised Phase B WP Areas I-IV (AECOM 2009b) NDEP approval: 1/16/09 | Revised DVSR Area IV (Northgate 2010c,h) NDEP approval: 3/29/10 | 1) HRA WP (Northgate 2010f) NDEP approval: 3/16/10 2) Revised HRA for RZ-A (Northgate 2010d) NDEP approval 8/20/10 | RZ-A RZ-B | N/A, throughout site | N/A, throughout site | Phase B Soil Gas WP (ENSR 2008a) NDEP approval: 3/08 | 1) Revised DVSR Soil Gas Survey (ENSR 2008f) NDEP approval: 10/20/08 2) Draft Report Soil Gas Survey Results (AECOM 2009a) | 1) HRA WP (Northgate 2010f) NDEP Approval: 3/16/10 2) Site-Wide Soil Gas HRA (Northgate 2010k) Not reviewed by NDEP |
| 61 | Unit 5 Basement & Old Sodium Chlorate Plant Decommission | III | -- | 1) Phase B Source Area III WP (ENSR 2008d) NDEP conditional approval: 7/21/08 2) Revised Phase B WP Areas I-IV (AECOM 2009b) NDEP approval: 1/16/09 3) Pre-Confirmation WP (Northgate 2010e) NDEP approval: 3/30/10 | Revised DVSR Area III (Northgate 2010b,l) NDEP approval: 3/17/10 | HRA WP (Northgate 2010f) NDEP approval: 3/16/10 | RZ-B | B7 | Category 1 | Phase B Soil Gas WP (ENSR 2008a) NDEP approval: 3/08 | 1) Revised DVSR Soil Gas Survey (ENSR 2008f) NDEP approval: 10/20/08 2) Draft Report Soil Gas Survey Results (AECOM 2009a) | 1) HRA WP (Northgate 2010f) NDEP Approval: 3/16/10 2) Site-Wide Soil Gas HRA (Northgate 2010k) Not reviewed by NDEP |
| 62 | State Industries, Inc. Site (Kerr-McGee tenant) | IV | -- | 1) Phase B Source Area IV WP (ENSR 2008e) NDEP conditional approval: 6/18/28 2) Revised Phase B WP Areas I-IV (AECOM 2009b) NDEP approval: 1/16/09 | Revised DVSR Area IV (Northgate 2010c,h) NDEP approval: 3/29/10 | 1) HRA WP (Northgate 2010f) NDEP approval: 3/16/10 2) Revised HRA for RZ-A (Northgate 2010d) NDEP approval 8/20/10 | RZ-A | -- | ? | Phase B Soil Gas WP (ENSR 2008a) NDEP approval: 3/08 | 1) Revised DVSR Soil Gas Survey (ENSR 2008f) NDEP approval: 10/20/08 2) Draft Report Soil Gas Survey Results (AECOM 2009a) | 1) HRA WP (Northgate 2010f) NDEP Approval: 3/16/10 2) Site-Wide Soil Gas HRA (Northgate 2010k) Not reviewed by NDEP |
| 63 | J.B. Kelley Trucking Inc. Site (Kerr-McGee tenant) | -- | F | 1) Phase 2 SAP Parcels C, D, F (BEC 2007d) NDEP approval: 11/20/07 2) Supplemental SAP Parcels C, D, F, G, and H (BEC 2008b) NDEP approval: 6/5/08 3) RAW Parcels C, D, F, G, and H (BEC 2008a) NDEP approval: 7/2/08 | 1) DVSR Parcels C, D, F, G, and H (ERM 2008) NDEP approval: 4/3/08 2) DVSR Parcels C, D, F, G, and H Supplemental Investigations (ERM 2009) NDEP approval: 1/12/09 3) Revised DVSR Parcels C, D, F, G, and H Soil Confirmation (Northgate 2010i) NDEP approval: 7/28/10 | Revised Closure and Post-Remediation HRA for Parcels C, D, F, G, and H (Northgate 2012) NDEP requested revised deliverable by 8/21/2012 | N/A, not in a zone | -- | N/A, not in a zone | -- | -- | No samples collected in Parcel F for Soil Gas HRA (Northgate 2010k) |
| 64 | Koch Materials Company Site (Kerr-McGee tenant) | I | -- | 1) Phase B Source Area I WP (ENSR 2008b) NDEP conditional approval: 5/6/08 2) Revised Phase B WP Areas I-IV (AECOM 2009b) NDEP approval: 1/16/09 3) Scope for Additional Sampling Area I (Northgate 2009a) NDEP approval: 11/24/09 4) Pre-Confirmation WP (Northgate 2010e) NDEP approval: 3/30/10 | 1) Revised DVSR Area I (Northgate 2010g,m) NDEP approval: 1/20/10 2) DVSR Shallow Supplemental Sampling Areas I and II (Neptune and Company 2010) NDEP approval: 7/28/10 | HRA WP (Northgate 2010f) NDEP approval: 3/16/10 | RZ-C | C2 | Category 1 | Phase B Soil Gas WP (ENSR 2008a) NDEP approval: 3/08 | 1) Revised DVSR Soil Gas Survey (ENSR 2008f) NDEP approval: 10/20/08 2) Draft Report Soil Gas Survey Results (AECOM 2009a) | 1) HRA WP (Northgate 2010f) NDEP Approval: 3/16/10 2) Site-Wide Soil Gas HRA (Northgate 2010k) Not reviewed by NDEP |

TABLE A-1. ROADMAP OF SITE SOIL AND SOIL GAS INVESTIGATIONS
Nevada Environmental Response Trust Site; Henderson, Nevada

| LOU | | Soil Investigations | | | | | | | | Soil Gas Investigations | | |
|-----|---|---------------------|-------------------------|--|---|--|--------------------|-----|----------------------------|---|--|---|
| # | Name | IA | Parcel | Investigation Work Plan | Reporting of Results | HRA | RZ ^a | ECA | Soil Category ^b | Investigation Work Plan | Reporting of Results | HRA |
| 65a | Ebony Construction Sites (Kerr-McGee tenant) | IV | -- | 1) Phase B Source Area IV WP (ENSR 2008e) NDEP conditional approval: 6/18/08 2) Revised Phase B WP Areas I-IV (AECOM 2009b) NDEP approval: 1/16/09 3) Pre-Confirmation WP (Northgate 2010e) NDEP approval: 3/30/10 | Revised DVSR Area IV (Northgate 2010c,h) NDEP approval: 3/29/10 | HRA WP (Northgate 2010f) NDEP approval: 3/16/10 | RZ-B | -- | Category 1 | -- | -- | -- |
| 65b | Buckles Construction Company (Kerr-McGee tenant) | IV | -- | 1) Phase B Source Area IV WP (ENSR 2008e) NDEP conditional approval: 6/18/08 2) Revised Phase B WP Areas I-IV (AECOM 2009b) NDEP approval: 1/16/09 3) Pre-Confirmation WP (Northgate 2010e) NDEP approval: 3/30/10 | Revised DVSR Area IV (Northgate 2010c,h) NDEP approval: 3/29/10 | HRA WP (Northgate 2010f) NDEP approval: 3/16/10 | RZ-B | -- | Category 1 | -- | -- | -- |
| 65c | Nevada Precast Concrete Products (Kerr-McGee tenant) | -- | F | 1) Phase 2 SAP Parcels C, D, F (BEC 2007d) NDEP approval: 11/20/07 2) Supplemental SAP Parcels C, D, F, G, and H (BEC 2008b) NDEP approval: 6/5/08 3) RAW Parcels C, D, F, G, and H (BEC 2008a) NDEP approval: 7/2/08 | 1) DVSR Parcels C, D, F, G, and H (ERM 2008) NDEP approval: 4/3/08 2) DVSR Parcels C, D, F, G, and H Supplemental Investigations (ERM 2009) NDEP approval: 1/12/09 3) Revised DVSR Parcels C, D, F, G, and H Soil Confirmation (Northgate 2010i) NDEP approval: 7/28/10 | Revised Closure and Post-Remediation HRA for Parcels C, D, F, G, and H (Northgate 2012) NDEP requested revised deliverable by 8/21/2012 | N/A, not in a zone | -- | N/A, not in a zone | -- | -- | No samples collected in Parcel F for Soil Gas HRA (Northgate 2010k) |
| 65d | Green Ventures International (Kerr-McGee tenant) | -- | G | 1) Phase 2 SAP Parcel G (BEC 2007c) NDEP approval: 10/29/07 2) Supplemental SAP Parcels C, D, F, G, and H (BEC 2008b) NDEP approval: 6/5/08 3) RAW Parcels C, D, F, G, and H (BEC 2008a) NDEP approval: 7/2/08 | 1) DVSR Parcels C, D, F, G, and H (ERM 2008) NDEP approval: 4/3/08 2) DVSR Parcels C, D, F, G, and H Supplemental Investigations (ERM 2009) NDEP approval: 1/12/09 3) Revised DVSR Parcels C, D, F, G, and H Soil Confirmation (Northgate 2010i) NDEP approval: 7/28/10 | Revised Closure and Post-Remediation HRA for Parcels C, D, F, G, and H (Northgate 2012) NDEP requested revised deliverable by 8/21/2012 | N/A, not in a zone | -- | N/A, not in a zone | -- | -- | -- |
| 66 | Above-Ground Diesel Storage Tank Leased by Flintkote Company on Chemstar Property (Kerr-McGee tenant) | IV | -- | 1) Phase B Source Area IV WP (ENSR 2008e) NDEP conditional approval: 6/18/28 2) Revised Phase B WP Areas I-IV (AECOM 2009b) NDEP approval: 1/16/09 | Revised DVSR Area IV (Northgate 2010c,h) NDEP approval: 3/29/10 | HRA WP (Northgate 2010f) NDEP approval: 3/16/10 | N/A, Chemstar site | -- | N/A, Chemstar site | -- | -- | -- |
| 67 | Delbert Madsen and Estate of Delbert Madsen Site (Kerr-McGee tenant) | -- | A | Phase 2 SAP Parcels A/B (BEC 2007b) NDEP Approved: 8/24/07 | 1) DVSR Parcels A/B (ERM 2007) NDEP approval: 12/6/07 2) Technical Memorandum Data Review Investigation Parcels A/B (BEC 2008c), Asbestos Data Review (BEC 2007a) & Uranium Data Review (BEC 2007e) NDEP Approved and Issued NFA: 4/8/08 | Technical Memorandum Data Review Investigation Parcels A/B (BEC 2008c) NDEP Issued NFA: 4/8/08 | N/A, not in a zone | -- | N/A, not in a zone | Phase B Soil Gas WP (ENSR 2008a) NDEP approval: 3/08 | 1) Revised DVSR Soil Gas Survey (ENSR 2008f) NDEP approval: 10/20/08 2) Draft Report Soil Gas Survey Results (AECOM 2009a) | 1) HRA WP (Northgate 2010f) NDEP Approval: 3/16/10 2) Site-Wide Soil Gas HRA (Northgate 2010k) Not reviewed by NDEP 3) Revised Indoor Air HRA Parcels A/B (Northgate 2010j) NDEP response: 8/31/10 NDEP Meeting Minutes: 9/7/10 |
| 68 | Southern Nevada Auto Parts Site (Kerr-McGee tenant) | -- | Portions of B, D, and I | 1) Phase 2 SAP Parcels A and B (BEC 2007b) NDEP Approved: 8/24/07 2) Phase 2 SAP Parcels C, D, F (BEC 2007d) NDEP approval: 11/20/07 3) Supplemental SAP Parcels C, D, F, G, and H (BEC 2008b) NDEP approval: 6/5/08 | 1) DVSR Parcels A/B (ERM 2007) NDEP approval: 12/6/07 2) Technical Memorandum Data Review Investigation Parcels A/B (BEC 2008c), Asbestos Data Review (BEC 2007a) & Uranium Data Review (BEC 2007e) NDEP Approved and Issued NFA: 4/8/08 3) DVSR Parcels C, D, F, G, and H (ERM 2008) NDEP approval: 4/3/08 4) DVSR Parcels C, D, F, G, and H Supplemental Investigations (ERM 2009) NDEP approval: 1/12/09 5) Revised DVSR Parcels C, D, F, G, and H Soil Confirmation (Northgate 2010i) NDEP approval: 7/28/10 | N/A, sold to Rolly Properties LLC in 2008 (as cited by ENVIRON 2012) and subsequently remediated (as cited by NDEP 2010) | N/A, not in a zone | -- | N/A, not in a zone | Phase B Soil Gas WP (ENSR 2008a) NDEP approval: 3/08 | 1) Revised DVSR Soil Gas Survey (ENSR 2008f) NDEP approval: 10/20/08 2) Draft Report Soil Gas Survey Results (AECOM 2009a) | 1) HRA WP (Northgate 2010f) NDEP Approval: 3/16/10 2) Site-Wide Soil Gas HRA (Northgate 2010k) Not reviewed by NDEP |

**TABLE A-1. ROADMAP OF SITE SOIL AND SOIL GAS INVESTIGATIONS
Nevada Environmental Response Trust Site; Henderson, Nevada**

| LOU | | Soil Investigations | | | | | | | | Soil Gas Investigations | | |
|-----|--|---------------------|--------|--|---|---|--------------------|-----|----------------------------|---|--|--|
| # | Name | IA | Parcel | Investigation Work Plan | Reporting of Results | HRA | RZ ^a | ECA | Soil Category ^b | Investigation Work Plan | Reporting of Results | HRA |
| 69 | Dillon Potter Site (Kerr-McGee tenant) | -- | J | N/A, sold to Robert and Sandra Ellis in 2008 (as cited by ENVIRON 2012) | N/A, sold to Robert and Sandra Ellis in 2008 (as cited by ENVIRON 2012) | N/A, sold to Robert and Sandra Ellis in 2008 (as cited by ENVIRON 2012) | N/A, not in a zone | -- | N/A, not in a zone | Phase B Soil Gas WP (ENSR 2008a) NDEP approval: 3/08 | 1) Revised DVSR Soil Gas Survey (ENSR 2008f) NDEP approval: 10/20/08 2) Draft Report Soil Gas Survey Results (AECOM 2009a) | 1) HRA WP (Northgate 2010f) NDEP Approval: 3/16/10 2) Site-Wide Soil Gas HRA (Northgate 2010k) Not reviewed by NDEP |
| 70 | US Vanadium Leasehold | III | -- | 1) Phase B Source Area III WP (ENSR 2008d) NDEP conditional approval: 7/21/08 2) Revised Phase B WP Areas I-IV (AECOM 2009b) NDEP approval: 1/16/09 | Revised DVSR Area III (Northgate 2010b,l) NDEP approval: 3/17/10 | HRA WP (Northgate 2010f) NDEP approval: 3/16/10 | N/A, active area | C18 | Category 1 | -- | -- | -- |

Notes:

-- = no value

The total risk estimates highlighted light gray in **bold** exceed 1×10^{-6} and the total risk estimates highlighted dark gray in **bold** exceed 1×10^{-5} .

AECOM = AECOM Inc.
 BCL = Basic comparison level
 BEC = Basic Environmental Company
 BMI = Black Mountain Industrial complex
 DVSR = Data validation summary report
 ECA = Excavation control area
 ENSR = ENSR Corporation
 ERM = ERM-West
 HRA = Health risk assessment
 IA = Investigation area
 LOU = Letter of understanding
 N/A = Not applicable
 NDEP = Nevada Division of Environmental Protection
 NFA = No further action
 Northgate = Northgate Environmental Management, Inc.
 RAW = Removal action work plan
 RZ = Remediation zone
 SAP = Sampling and analysis plan
 SMP = Site management plan
 WP = Work plan

Remediation Zones:

RZ-A = Area on the southern portion of the site
 RZ-B = Area around the Unit buildings
 RZ-C = Ammonia perchlorate production area, Koch Materials area, pond and diesel storage tank area, and manganese tailings area
 RZ-D = Trade Effluent ponds and ammonium perchlorate pad/drum recycling area (including the hazardous waste landfill)
 RZ-E = Beta Ditch

Soil Categories:

Category 1 = soils in ECAs (risks managed through SMP, quantitative risk assessment not required)
 Category 2 = soil concentrations less than BCLs at 0-10 feet below ground surface and not identified as an ECA (quantitative risk assessment not required)
 Category 3 = soil concentrations greater than BCLs at 0-10 feet below ground surface at excavation areas that were not backfilled to original grade and not identified as an ECA (quantitative risk evaluation required for soil 'pathways)
 Category 4 = soils not previously sampled or available information considered inadequate (risk assessment approach to be determined)

^a Certain former tenant areas are not within the designated Remediation Zones.

^b Surface and near surface soils (0-10 feet below ground surface following soil removal actions) were placed into one of four categories.

^c Soil gas sample number SG45 was assigned to Area IV for analysis purposes since this sample was collected in the acid drain system west of Area IV.

References:

AECOM Inc. (AECOM). 2009a. Draft Report: Phase B Source Area Investigation Soil Gas Survey Results for the Tronox Facility, Henderson, Nevada. May 15.
 AECOM, 2009b. Response-to-Comments (RTC) to NDEP Response to Revised Phase B Site Investigation Work Plan, Text, Tables, and Figures, Tronox LLC Facility Henderson, Nevada, Dated January 16.
 BEC (Basic Environmental Company), 2007a. Asbestos Data Review for 2007 Tronox Parcels A/B Investigation, BMI Industrial Complex, Clark County, Nevada. December 17.
 BEC, 2007b. Phase 2 Sampling and Analysis Plan to Conduct Soil Characterization, Tronox Parcels "A" and "B" Site, Henderson, Nevada (Revision 1). August 14.
 BEC, 2007c. Phase 2 Sampling and Analysis Plan to Conduct Soil Characterization, Tronox Parcel "G" Site, Henderson, Nevada. September 27.
 BEC, 2007d. Phase 2 Sampling and Analysis Plan to Conduct Soil Characterization, Tronox Parcel "H" Site and Errata Pages for Phase 2 Sampling and Analysis Plans to Conduct Soil Characterization, Tronox Parcels "C", "D" and "F" Sites, Henderson, Nevada. November 8.
 BEC, 2007e. Uranium Isotope Data Review for 2007 Tronox Parcels A/B Investigation, BMI Industrial Complex, Clark County, Nevada. December 18.
 BEC, 2008a. Removal Action Workplan for Soil, Tronox Parcels "C", "D", "F", "G", and "H" Sites, Henderson Nevada. July 1.
 BEC, 2008b. Sampling and Analysis Plan to Conduct Supplemental Soil Characterization, Tronox Parcels "C", "D", "F", "G", and "H", Henderson, Nevada, Dated May 28, 2008. June 5.
 BEC, 2008c. Technical Memorandum - Data Review for 2007 Tronox Parcels A/B Investigation, BMI Industrial Complex, Clark County, Nevada. February 11.

**TABLE A-1. ROADMAP OF SITE SOIL AND SOIL GAS INVESTIGATIONS
Nevada Environmental Response Trust Site; Henderson, Nevada**

ENSR Corporation (ENSR), 2008a. Phase B Source Area Investigation Soil Gas Survey Work Plan Tronox LLC Facility Henderson, Nevada. March
ENSR, 2008b. Phase B Source Area Investigation Work Plan Area I (Northern LOUs) Tronox LLC Facility Henderson, Nevada. April
ENSR, 2008c. Phase B Source Area Investigation Work Plan Area II (Central LOUs) Tronox LLC Facility Henderson, Nevada. June.
ENSR, 2008d. Phase B Source Area Investigation Work Plan Area III (Eastern LOUs) Tronox LLC Facility Henderson, Nevada. June.
ENSR, 2008e. Phase B Source Area Investigation Work Plan Area IV (Western and Southern LOUs) Tronox LLC Facility Henderson, Nevada. May.
ENSR, 2008f. Phase B Source Area Investigation Revisions to Area I through IV Work Plans Draft Text/Drawing Submittal - November 10, 2008. November 7.
ENSR, 2008f. Revised Data Validation Summary Report Phase B Source Area Investigation Soil Gas Survey - Tronox LLC Facility Henderson, Nevada. Octobe
ENVIRON. 2011. Phase I Environmental Site Assessment of Tronox LLC Clark County, Nevada. January.
ENVIRON. 2012. Site Management Plan (SMP) Nevada Environmental Response Trust Site, Clark County, Nevada. May 30
ERM-West (ERM), 2007. Data Validation Summary Report (DVSR) Tronox Parcels A/B Investigation, August-September 2007 (Dataset 47), BMI Industrial Complex, Clark County, Nevada. November
ERM, 2008. Data Validation Summary Report (DVSR) Tronox Parcels C, D, F, G, and H Investigation, November 2007, BMI Industrial Complex, Clark County, Nevada, (Revised) Dated March, 28, 2008. April 3
ERM, 2009. Data Validation Summary Report (DVSR) Tronox Parcels C, D, F, G, and H Supplemental Investigations, June-July 2008, BMI Industrial Complex, Clark County, Nevada, Dated January 7, 2009. January 12
Neptune and Company. 2010. Revised Data Validation Summary Report For Shallow Supplemental Soil Sampling in Areas I and II. July 21
Nevada Division of Environmental Protection (NDEP), 1994. Phase II Letter of Understanding Between NDEP and Kerr-McGee Chemical Corporation (KMCC). August 15
Nevada Division of Environmental Protection (NDEP), 2007a. NDEP Response to: Data Validation Summary Report, Parcels A/B Investigation, August - September 2007, BMI Industrial Complex, Clark County, Nevada, Dated November 28, 2007. December 6
NDEP, 2007b. NDEP Response to: Phase 2 Sampling and Analysis Plan to Conduct Soil Characterization, Tronox Parcels "A" and "B" Site, Henderson, Nevada dated August 14, 2007. August 24
NDEP, 2007c. NDEP Response to: Phase 2 Sampling and Analysis Plan to Conduct Soil Characterization, Tronox Parcel "G" Site, Henderson, Nevada, Revision 1, Dated September 27, 2007. October 29
NDEP, 2007d. NDEP Response to: Phase 2 Sampling and Analysis Plan to Conduct Soil Characterization, Tronox Parcel "H" Site and Errata Pages for Phase 2 Sampling and Analysis Plans to Conduct Soil Characterization, Tronox Parcels "C", "D", and "F" Sites, Henderson, Nevada, Dated November 8, 2007. November 2
NDEP, 2007e. NDEP Response to: Phase 2 Sampling and Analysis Plan to Conduct Soil Characterization, Tronox Parcel "H" Site, Henderson, Nevada, Revision 1, Dated December 12, 2007. December 17
NDEP, 2008a. NDEP Response to: Data Validation Summary Report (DVSR) for the Tronox Parcels C, D, F, and G Investigation, November 2007, BMI Industrial Complex, Clark County, Nevada (Revised), Dated March 28, 2008. April 3
NDEP, 2008b. NDEP Response to: Phase B Source Area Investigation Soil Gas Survey Work Plan Tronox LLC Facility Henderson, Nevada, Dated March. March
NDEP, 2008c. NDEP Response to: Phase B Source Area Investigation Work Plan Area I (Northern LOUs). Tronox LLC Facility, Henderson, Nevada Dated April 3, 2008. May 6
NDEP, 2008d. NDEP Response to: Phase B Source Area Investigation Work Plan Area II (Central LOUs). Tronox LLC Facility, Henderson, Nevada Dated June 27, 2008. July 21
NDEP, 2008e. NDEP Response to: Phase B Source Area Investigation Work Plan Area III (Eastern LOUs). Tronox LLC Facility, Henderson, Nevada Dated June 27, 2008. July 21
NDEP, 2008f. NDEP Response to: Phase B Source Area Investigation Work Plan Area IV (Western and Southern LOUs). Tronox LLC Facility, Henderson, Nevada Dated May 16, 2008. June 18
NDEP, 2008g. NDEP Response to: Removal Action Workplan for Soil, Tronox Parcels "C", "D", "F", "G", and "H" Sites, Henderson, Nevada, Dated July 1, 2008. July 2
NDEP, 2008h. NDEP Response to: Revised Data Validation Summary Report (DVSR), Phase B Source Area Investigation Soil Gas Survey - Tronox LLC Facility, Henderson, Nevada, Dated October 13, 2008. October 20
NDEP, 2008i. NDEP Response to: Sampling and Analysis Plan to Conduct Supplemental Soil Characterization, Tronox Parcels "C", "D", "F", "G", and "H", Henderson, Nevada, Dated May 28, 2008. June 5
NDEP, 2008j. NDEP Response (Part 1) to: Technical Memorandum Data Review for 2007 Tronox Parcels A/B Investigation Dated December 6, 2007 And Asbestos Data Review for 2007 Tronox A/B Investigation dated December 17, 2007 And Uranium Isotope Data Review for 2007 Tronox A/B Investigation date
December 18, 2007 And Asbestos Data Review for 2007 Tronox A/B Investigation Dated January 9, 2008 And Supplemental information provided via electronic mail various dates. January 17
NDEP, 2008k. NDEP Response to: Technical Memorandum Data Review for 2007 Tronox Parcels A/B Investigation, Dated February 11, 2008. April 8
NDEP, 2009a. NDEP Response to: Data Validation Summary Report (DVSR) Tronox Parcels C, D, F, G, and H Supplemental Investigations, June-July 2008, BMI Industrial Complex, Clark County, Nevada, Dated January 7, 2009. January 12
NDEP, 2009b. NDEP Response to: Memorandum: Scope for Additional Sampling - Phase B Investigation, Area I (including subsequently submitted supporting data and figures) Dated November 19, 2009. November 24
NDEP, 2009c. Quality Assurance Project Plan (QAPP) Tronox LLC Facility, Henderson, Nevada, Dated July, 20 2009 (Revised). July 27
NDEP, 2009c. NDEP Response to: Response-to-Comments (RTC) to NDEP Response to Revised Phase B Site Investigation Work Plan, Text, Tables, and Figures, Tronox LLC Facility Henderson, Nevada (includes revised Field Tables for Areas I - IV and revised Figure 4), Dated January 16, 2009. January 16
NDEP, 2009d. NDEP Response to: Tronox Area II Supplemental Sampling (email), Dated December 14, 2009. January 14
NDEP, 2010a. NDEP Response to: Data Validation Summary Report for Shallow Supplemental Soil Sampling in Areas I and II, Tronox LLC Facility, Henderson, Nevada, Dated July 21, 2010. July 28
NDEP, 2010b. NDEP Response to: Data Validation Summary Report, Phase B Investigation Area II Soil, Tronox LLC, Henderson, Nevada, Dated February 12, 2010. February 18
NDEP, 2010c. NDEP Response to: Errata to Revised RZ-A Human Health Risk Assessment, Tronox LLC, Henderson, Nevada, Dated: July 23, 2010. August 20
NDEP, 2010d. NDEP Response to: Final Revised Pre-Confirmation Sampling Work Plan, Remediation Zones RZ-A through RZ-E, Phase B Investigation, Tronox Facility, Henderson Nevada, Dated: March 25, 2010. March 30
NDEP, 2010e. NDEP Response to: Health Risk Assessment Work Plan, Phase B Investigation, Tronox LLC, Henderson, Nevada, Dated March 9, 2012. March 16
NDEP, 2010f. NDEP Response to: Revised Electronic Data Deliverable for Data Validation Summary Report: Parcel "C", "D", "F", "G" and "H" Soil Confirmation, Tronox LLC, Henderson, Nevada, Dated July 21. July 28
NDEP, 2010g. NDEP Response to: Revised Data Validation Summary Report, Phase B Investigation Area I Soil, Tronox LLC, Henderson, Nevada, Dated January 15, 2010. January 20
NDEP, 2010h. NDEP Response to: Revised Data Validation Summary Report Phase B Investigation Area IV Soil, Dated March 19, 2010. March 29
NDEP, 2010i. NDEP Response to: Revised Technical Memorandum: Screening-Level Indoor Air Health Assessment for the 2008 Tronox Parcels A/B Soil Gas Investigation, Tronox LLC, Henderson, Nevada, Dated: June 29, 2010. August 31
NDEP, 2010j. NDEP Response to: Technical Memorandum – Screening-Level Indoor Air Health Risk Assessment for the 2008 Tronox Parcels A/B Soil Gas Investigation, BMI Industrial Complex, Clark County, Nevada Dated
March 30, 2010. May 13.
NDEP, 2010j. NDEP Response to: Tronox Letter Re: Status of Remediation Activities Parcels "C", "D", "F", "G", and "H," Dated March 24, 2010. March 26
NDEP, 2010j. Tronox (TRX) Project Meeting Minutes. September 7.
NDEP, 2010k. NDEP Response to: Tronox Response to NDEP 2-26-10 Comments Regarding: Tronox's Data Validation Summary Report, Phase B Investigation Area III Soil, Tronox LLC, Henderson, Nevada, Dated February 18, 2010. March 17
NDEP, 2010m. TRX Sale Parcels A through K. January 7.
NDEP, 2011. Action Memorandum: Removal Actions, Nevada Environmental Response Trust Site, Clark County, Nevada. July 21.
Northgate Environmental Management, Inc. (Northgate). 2009a. Memorandum: Scope for Additional Sampling - Phase B Investigation, Area I. November 19
Northgate, 2009b. Tronox Area II Supplemental Sampling (email). December 14.
Northgate, 2010a. Data Validation Summary Report, Phase B Investigation Area II Soil, Tronox LLC, Henderson, Nevada. February 12
Northgate, 2010b. Data Validation Summary Report, Phase B Investigation Area III Soil, Tronox LLC, Henderson, Nevada. February 18
Northgate, 2010c. Data Validation Summary Report, Phase B Investigation Area IV Soil, Tronox LLC, Henderson, Nevada. February 18
Northgate, 2010d. Errata to Revised Human Health Risk Assessment for Remediation Zone A, Tronox LLC, Henderson, Nevada. July 23.
Northgate, 2010e. Final Revised Pre-Confirmation Sampling Work Plan Remediation Zones RZ-A through RZ-E Phase B Investigation, Tronox Facility, Henderson, Nevada. March 25
Northgate, 2010f. Health Risk Assessment Work Plan, Tronox LLC Facility, Henderson, Nevada. March 9.
Northgate, 2010g. Revised Data Validation Summary Report, Phase B Investigation Area I Soil, Tronox LLC, Henderson, Nevada. January 15
Northgate, 2010h. Revised Data Validation Summary Report Phase B Investigation Area IV Soil. March 19.
Northgate, 2010i. Revised Electronic Data Deliverable (EDD) for the Data Validation Summary Report for Parcel "C", "D", "F", "G" and "H" Soil Confirmation, Tronox LLC, Henderson, Nevada, Dated June 15, 2010. July 21
Northgate, 2010j. Revised Technical Memorandum: Screening-Level Indoor Air Health Risk Assessment for the 2008 Tronox Parcels A/B Soil Gas Investigation, BMI Industrial Complex, Clark County, Nevada. November 12
Northgate, 2010k. Site-Wide Soil Gas Human Health Risk Assessment Tronox LLC Henderson, Nevada. November 22.
Northgate, 2010l. Tronox Response to NDEP 2-26-10 Comments Regarding: Tronox's Data Validation Summary Report, Phase B Investigation Area III Soil, Tronox LLC, Henderson, Nevada, Dated February 18, 2010. March 10
Northgate, 2010m. Tronox Response to NDEP 1-20-10 Comments Regarding: Tronox's Revised Data Validation Summary Report Phase B Investigation Area I Soil, Dated January 15, 2010. February 11
Northgate, 2012. Revised Closure and Post-Remediation Screening Health Risk Assessment Report for Parcels C, D, F, G, and H, Nevada Environmental Response Trust Site, Henderson, Nevada. May 18

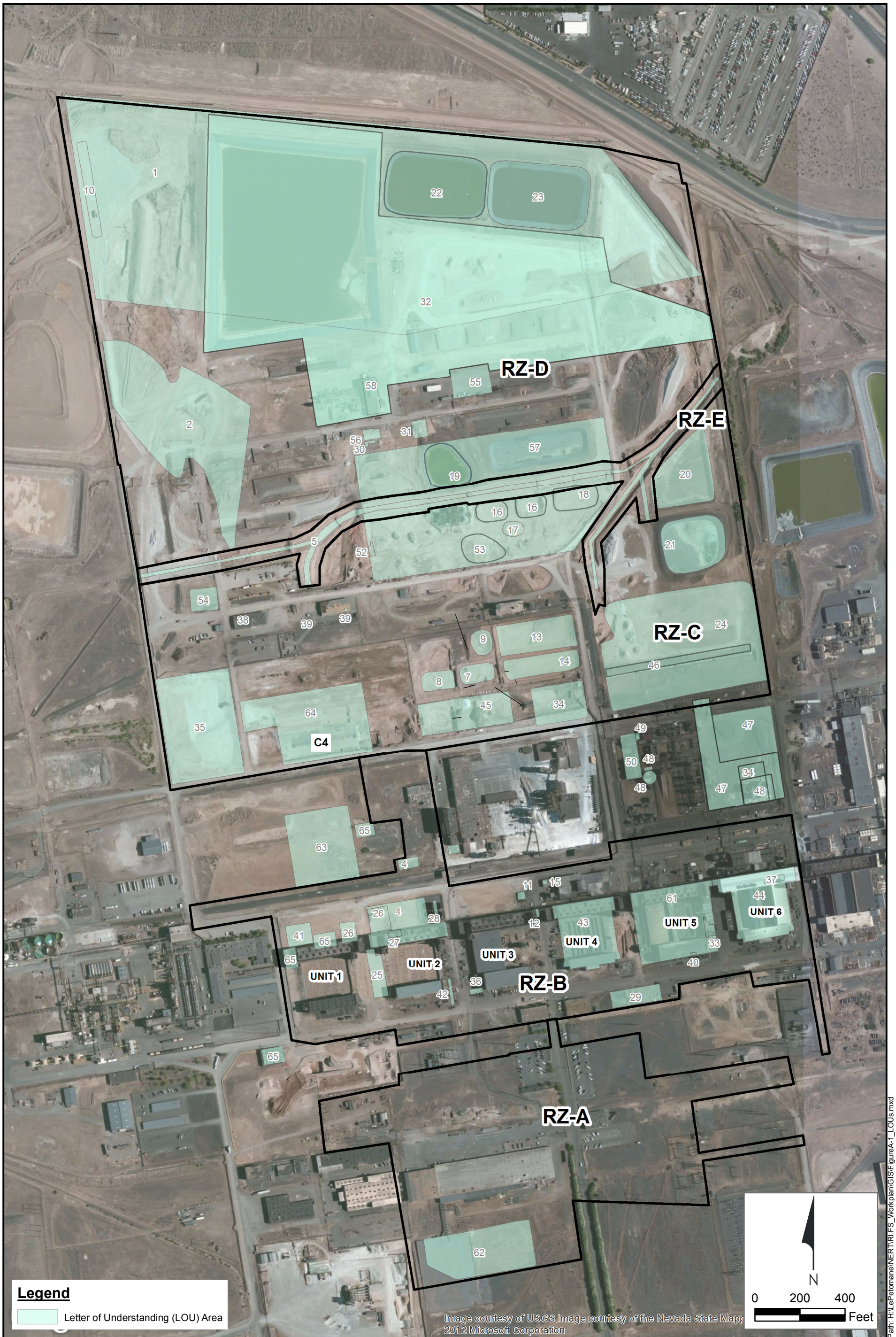

Path: H:\LePatomane\NERT\RFIS_Workplan\GIS\FigureA-1_LOUs.mxd

Legend
 Letter of Understanding (LOU) Area

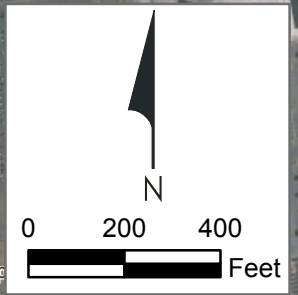

Image courtesy of USGS Image courtesy of the Nevada State Map 2012 Microsoft Corporation

| LOU # | LOU Description |
|-------|---|
| 1 | Trade Effluent Settling Ponds |
| 2 | Open Area Due South of Trade Effluent Settling Ponds |
| 3 | Air Pollution Emissions Associated with Industrial Processes |
| 4 | Former Hardesty Chemical Company Site |
| 5 | On-Site Portion of Beta Ditch Including the Small Diversion Ditch |
| 6 | Unnamed Drainage Ditch Segment |
| 7 | Old P-2 Surface Impoundment |
| 8 | Old P-3 Surface Impoundment |
| 9 | New P-2 Pond and Associated Piping |
| 10 | On-Site Hazardous Landfill |
| 11 | Sodium Chlorate Filter Cake Area North of Unit 3 |
| 12 | Hazardous Waste Storage Area Between Units 3 and 4 |
| 13 | Closed Surface Impoundment S-1 |
| 14 | Closed Surface Impoundment P-1 |
| 15 | Platinum Drying Unit North of Unit 4 |
| 16 | Ponds AP-1, AP-2 and AP-3 and Associated Transfer Lines |
| 17 | Ponds AP-1, AP-2 and AP-3 and Associated Transfer Lines |
| 18 | Pond AP-4 |
| 19 | Pond AP-5 |
| 20 | Pond C-1 and Associated Piping |
| 21 | Pond MN-1 and Associated Piping |
| 22 | Ponds WC-West and Associated Piping |
| 23 | Ponds WC-East and Associated Piping |
| 24 | Leach Beds, Associated Conveyance Facilities and Former Manganese Tailings Area |
| 25 | Process Hardware Storage Area Between Units 1 and 2 |
| 26 | Trash Storage Area North of Units 1 and 2 |
| 27 | PCB Storage Area - Unit 2 |
| 28 | Hazardous Waste Storage Area North of Unit 2 |
| 29 | Solid Waste Dumpsters |
| 30 | Ammonium Perchlorate Area- Pad 35 |
| 31 | Drum Crushing and Recycling Area |
| 32 | Groundwater Remediation Unit |
| 33 | Sodium Perchlorate Platinum By-Product Filter |
| 34 | Manganese Tailings Area |
| 35 | Truck Unloading Area |
| 36 | Former Satellite Accumulation Point - Unit 3, Maintenance Shop |
| 37 | Former Satellite Accumulation Point - Unit 6, Maintenance Shop |
| 38 | Former Satellite Accumulation Point - AP Laboratory |
| 39 | Former Satellite Accumulation Point - AP Maintenance Shop |
| 40 | PCB Transformer Spill |
| 41 | Unit 1 Tenants - Stains |
| 42 | Unit 2 Salt Redler |
| 43 | Unit 4 and 5 Basements |
| 44 | Unit 6 Basements |
| 45 | Diesel Storage Tank Area - Stains |
| 46 | Former Old Main Cooling Tower and Recirculation Lines |
| 47 | Leach Plant Area Manganese Ore Piles |
| 48 | Leach Plant Area Anolyte Tanks |
| 49 | Leach Plant Area Sulfuric Acid Storage Tank |
| 50 | Leach Plant Area Leach Tanks |
| 51 | Leach Plant Area Transfer Lines To/From Unit 6 |
| 52 | AP Plant Area Screening Building, Dryer Building, and Associated Sump |
| 53 | AP Plant Area Tank Farm |
| 54 | AP Plant Area Change House/Laboratory and Septic Tank |
| 55 | AP Plant Area Storage Pads - Fire |
| 56 | AP Plant Area Old Building D-1 Washdown |
| 57 | AP Plant Area New Building D-1 Washdown |
| 58 | AP Plant SI and Transfer Lines To/From AP SI |
| 59 | Storm Sewer System |
| 60 | Acid Drain System |
| 61 | Old Sodium Chlorate Plant Decommissioning |
| 62 | State Industries Inc. Site, Including Impoundments and Catch Basin |
| 63 | J.B. Kellet, Inc. Trucking Site |
| 64 | Koch Materials Company |
| 65 | Assorted KMCC Tenants |
| 66 | Flintkote Company |
| 67 | Delbert Madsen and Estate of Delbery Madsen |
| 68 | Southern Nevada Auto Parts Site |
| 69 | Dillon Potter Site |
| 70 | US Vanadium Leasehold |

LOUs 68 through 70 are not displayed in this map's extent.

Path: H:\LePetomane\NERT\RI_FS_Workplan\GIS\FigureA2_LOUdescription.mxd



2200 Powell St., Suite 700, Emeryville, CA 94608

LOU Locations

Nevada Environmental Response Trust Site, Henderson, Nevada

Figure
A-1

Drafter: EA

Date: 12/17/2012

Contract Number: 21-29100H

Approved by:

Revised:

Appendix B
Soil Remediation Goals for the
2011 Interim Soil Removal Action

Contents

| | | |
|----------|--|----------|
| B | Soil Remediation Goals for the 2011 Interim Soil Removal Action | 1 |
| B.1 | Dioxin | 1 |
| B.2 | Asbestos | 1 |
| B.3 | Arsenic | 1 |
| B.4 | Total Petroleum Hydrocarbons | 2 |
| B.5 | Chemicals with Updated BCLs | 2 |
| B.6 | References | 3 |

List of Tables

| | |
|-----------|-------------------------------|
| Table B-1 | Soil Remediation Goals (SRGs) |
|-----------|-------------------------------|

B Soil Remediation Goals for the 2011 Interim Soil Removal Action

Tronox performed two soil sampling programs (known as Phase A and B Source Area Investigations) that were completed in 2006 and 2008, respectively (ENSR-AECOM, 2006 and 2008). The results of the Phase A and B investigations identified a number of constituents within the upper 10 feet (ft) of soil in excess of Nevada Division of Environmental Protection (NDEP) worker Basic Comparison Levels (BCLs) or modified risk-based goals (as agreed upon by NDEP), which are collectively referred to as "soil remediation goals" (SRGs). The SRGs applied during the soil interim removal action (ENVIRON 2012) were generally taken from the January 2011 BCL Table (NDEP 2011). The identified chemicals of potential concern (COPCs) exceeding SRGs included dioxin toxicity equivalents (TEQs), hexachlorobenzene (HCB), other semivolatile organic compounds (SVOCs), polychlorinated biphenyls (PCBs), asbestos, metals, organochlorine pesticides (OCPs), and perchlorate.

A 2009 Division Order (NDEP 2009) directed Tronox to remove all soil containing COPCs in excess of the SRGs from the Site, thus reducing the human health risks associated with contaminated soil. The SRGs applied at the time of the interim soil removal action are listed in Table B-1.

The following sections summarize the SRGs for specific chemicals that (1) have site-specific values, (2) are based on regional background soil concentrations, or (3) do not have NDEP BCLs (and for which alternative values were used). In addition, Section B.5 identifies BCLs that have been updated (NDEP 2012) since completion of the interim soil removal action. NDEP BCLs current at the time of any future removal or remedial actions will be used for future comparisons.

B.1 Dioxin

The SRG listed in Table B-1 for dioxin toxicity equivalents (TEQ) is 2,700 parts per trillion (ppt). This value was derived based on *Northgate's Bioaccessibility Study for Dioxins/Furans in Soil* (Northgate 2010a) and approved by NDEP as a site-specific risk based concentration for dioxins/furans (in terms of a 2,3,7,8-TCDD TEQ) (NDEP 2010).

B.2 Asbestos

There are no NDEP BCLs for asbestos. For purposes of the interim soil removal action, "contaminated" soil was defined as one or more long amphibole fibers and greater than five long chrysotile fibers counted per sample as indicated in Table B-1.

B.3 Arsenic

For metals where background concentrations exceed NDEP BCLs, "contaminated" soil was defined as concentrations greater than background. Specifically, the arsenic SRG of 7.2 milligrams per kilogram (mg/kg) was based on regional background soil data from the McCullough Range and presented in *Background Shallow Soil Summary Report, BMI Complex and Common Area Vicinity* (Basic Remediation Company and Titanium Metals Corporation [BRC/TIMET] 2007). The arsenic background shallow soil concentration from the Remediation

Zone A (RZ-A) background soil data set is 4.25 mg/kg for 0 to 2 ft below ground surface (bgs) and 3.13 mg/kg for 2 to 10 ft bgs, as presented in *Northgate's Technical Memorandum: Background Comparison for Metals in Remediation Zones B through E, Compared to Remediation Zone A* (Northgate 2010b).

B.4 Total Petroleum Hydrocarbons

Petroleum hydrocarbon mixtures in soils, such as gasoline, kerosene, diesel, or waste oils, are relatively common, and some groups have developed noncancer toxicity criteria based on selected petroleum fractions such as gasoline- or diesel-range hydrocarbons. NDEP does not recommend using these petroleum fraction toxicity criteria and has therefore not developed a BCL (NDEP 2012). In accordance with NDEP guidance (NDEP 2012), the indicator chemicals for common petroleum hydrocarbon mixtures, including benzene, toluene, ethylbenzene, and total xylenes (BTEX); methyl tert-butyl ether (MTBE); and polycyclic aromatic hydrocarbons (PAHs), were compared to their respective SRGs. In addition, as presented in Table B-1, 100 mg/kg was used for the SRG for total petroleum hydrocarbon fractions of oil, gasoline, and diesel.

B.5 Chemicals with Updated BCLs

The BCLs for the following chemicals have been updated since the SRGs were developed: alpha-benzene hydrochloride (alpha-BHC); beta-BHC; gamma-BHC (Lindane); 1,4-dioxane; 1,2,4-trichlorobenzene; and bromodichloromethane. The BCLs used for alpha-BHC, beta-BHC, and Lindane have increased approximately 675-fold, 40-fold, and 5-fold, respectively. The SRG used as the basis for soil remediation for 1,4-dioxane was 174 mg/kg. Since then, the BCL has been lowered nearly 10-fold. The SRG used as the basis for soil remediation for 1,2,4-trichlorobenzene was 759 mg/kg; the BCL was lowered approximately 7-fold. The SRG used as the basis for soil remediation for bromodichloromethane was 51.3 mg/kg; the BCL was lowered almost 15-fold.

B.6 References

- Basic Remediation Company and Titanium Metals Corporation (BRC/TIMET), 2007. Background Shallow Soil Summary Report, BMI Complex and Common Areas Vicinity. March 16. NDEP approval status unknown.
- ENSR-AECOM. 2006. Phase A Source Area Investigation Work Plan, Tronox LLC Facility, Henderson, Nevada. September.
- ENSR-AECOM. 2008. Phase B Source Area Investigation Work Plan, Tronox LLC Facility, Henderson, Nevada. April.
- ENVIRON International Corporation (ENVIRON), 2012. Interim Soil Removal Action Completion Report, Nevada Environmental Response Trust Site, Henderson Nevada, January.
- Nevada Division of Environmental Protection (NDEP). 2009. Letter to Tronox, LLC re: Enforcement Action for Failure to Complete Approved Site Remediation Activities, and Show Cause Meeting, Tronox, LLC, (Tronox) Henderson, Nevada, NDEP Facility ID Number 8-000539. December 14.
- NDEP, 2010. NDEP Response to: Results of Bioaccessibility Study for Dioxin/Furans in Soil, Tronox LLC, Henderson, Nevada (Revised) Dated: May 24, 2010, May 25.
- NDEP, 2011. User's Guide and Background Technical Document for Nevada Division of Environmental Protection (NDEP) Basic Comparison Levels (BCLs) for Human Health for the BMI Complex and Common Areas, Revision 6, January 2011.
- NDEP, 2012. User's Guide and Background Technical Document for the Nevada Division of Environmental Protection (NDEP) Basic Comparison Levels (BCLs) for Human Health for the BMI Complex and Common Areas, Revision 8. May 2012.
- Northgate Environmental Management, Inc. (Northgate), 2010a. Results of Bioaccessibility Study for Dioxin/Furans in Soil, Tronox LLC, Henderson, Nevada. May 24. NDEP approved May 25, 2010.
- Northgate, 2010b. Technical Memorandum: Background Comparison for Metals in Remediation Zones B through E, Compared to Remediation Zone A, July 22. NDEP commented on August 9, 2010.

**TABLE B-1. SOIL REMEDIATION GOALS (SRGs)
Nevada Environmental Response Trust Site; Henderson, Nevada**

| PARAMETER OF INTEREST | CHEMICAL | UNIT | NDEP 2011 WORKER BCL ^a OR SITE-SPECIFIC SCREENING LEVEL | BASIS | |
|----------------------------|---------------------------------|---------------------|--|-------|----|
| Organic Acids | 4-Chlorobenzenesulfonic acid | mg/kg | 117 | sat | |
| | Benzenesulfonic acid | mg/kg | 100,000 | max | |
| | Diethyl phosphorodithioic acid | mg/kg | 90,800 | N | |
| | Dimethyl phosphorodithioic acid | mg/kg | 100,000 | max | |
| | Phthalic acid | mg/kg | 100,000 | max | |
| Organophosphate Pesticides | Azinphos-Methyl | mg/kg | -- | -- | |
| | Bolstar | mg/kg | -- | -- | |
| | Chlorpyrifos | mg/kg | 2,050 | N | |
| | Coumaphos | mg/kg | -- | -- | |
| | Demeton-O | mg/kg | -- | -- | |
| | Demeton-S | mg/kg | -- | -- | |
| | Diazinon | mg/kg | 616 | N | |
| | Dichlorvos | mg/kg | 6.6 | C | |
| | Dimethoate | mg/kg | -- | -- | |
| | Disulfoton | mg/kg | 27.4 | N | |
| | EPN | mg/kg | -- | -- | |
| | Ethoprop | mg/kg | -- | -- | |
| | Ethyl Parathion | mg/kg | 4,100 | N | |
| | Famphur | mg/kg | -- | -- | |
| | Fensulfothion | mg/kg | -- | -- | |
| | Fenthion | mg/kg | -- | -- | |
| | Malathion | mg/kg | 13,700 | N | |
| | Merphos | mg/kg | -- | -- | |
| | Methyl Parathion | mg/kg | 171 | N | |
| | Mevinphos | mg/kg | -- | -- | |
| | Naled | mg/kg | 1,370 | N | |
| | Phorate | mg/kg | -- | -- | |
| | Ronnel | mg/kg | 34,200 | N | |
| | Stirophos | mg/kg | 79.8 ^b | N | |
| Sulfotep | mg/kg | -- | -- | | |
| Thionazin | mg/kg | -- | -- | | |
| Tokuthion | mg/kg | -- | -- | | |
| Trichloronate | mg/kg | -- | -- | | |
| Organochlorine Pesticides | 4,4'-DDD | mg/kg | 11.1 | C | |
| | 4,4'-DDE | mg/kg | 7.81 | C | |
| | 4,4'-DDT | mg/kg | 7.81 | C | |
| | Aldrin | mg/kg | 0.113 | C | |
| | Alpha-BHC | mg/kg | 0.399 | C | |
| | Alpha-chlordane | mg/kg | -- | -- | |
| | Beta-BHC | mg/kg | 1.4 | C | |
| | Delta-BHC | mg/kg | -- | -- | |
| | Dieldrin | mg/kg | 0.12 | C | |
| | Endosulfan I | mg/kg | -- | -- | |
| | Endosulfan II | mg/kg | -- | -- | |
| | Endosulfan Sulfate | mg/kg | -- | -- | |
| | Endrin | mg/kg | 205 | N | |
| | Endrin Aldehyde | mg/kg | -- | -- | |
| | Organochlorine Pesticides | Endrin Ketone | mg/kg | -- | -- |
| | | Gamma-BHC (Lindane) | mg/kg | 1.93 | C |
| Gamma-chlordane | | mg/kg | -- | -- | |

**TABLE B-1. SOIL REMEDIATION GOALS (SRGs)
Nevada Environmental Response Trust Site; Henderson, Nevada**

| PARAMETER OF INTEREST | CHEMICAL | UNIT | NDEP 2011 WORKER BCL ^a OR SITE-SPECIFIC SCREENING LEVEL | BASIS |
|---------------------------|--------------------------------|-------|--|-------|
| Organochlorine Pesticides | Heptachlor | mg/kg | 0.426 | C |
| | Heptachlor Epoxide | mg/kg | 0.21 | C |
| | Methoxychlor | mg/kg | 3,420 | N |
| | Tech-Chlordane | mg/kg | 7.19 | C |
| | Toxaphene | mg/kg | 1.74 | C |
| SVOCs | 1,4-Dioxane | mg/kg | 174 | C |
| | 2-Methylnaphthalene | mg/kg | -- | -- |
| | Acenaphthene | mg/kg | 2,560 | N |
| | Acenaphthylene | mg/kg | 147 | sat |
| | Anthracene | mg/kg | 9,920 | N |
| | Benz(a)anthracene | mg/kg | 2.34 | C |
| | Benzo(a)pyrene | mg/kg | 0.234 | C |
| | Benzo(b)fluoranthene | mg/kg | 2.34 | C |
| | Benzo(g,h,i)perylene | mg/kg | 34,100 | N |
| | Benzo(k)fluoranthene | mg/kg | 23.4 | C |
| | bis(2-Ethylhexyl)phthalate | mg/kg | 137 | C |
| | Butyl benzyl phthalate | mg/kg | 240 | sat |
| | Chrysene | mg/kg | 234 | C |
| | Dibenz(a,h)anthracene | mg/kg | 0.234 | C |
| | Diethyl phthalate | mg/kg | 100,000 | max |
| | Dimethyl phthalate | mg/kg | 100,000 | max |
| | Di-N-Butyl phthalate | mg/kg | 68,400 | N |
| | Di-N-Octyl phthalate | mg/kg | -- | -- |
| | Fluoranthene | mg/kg | 24,400 | N |
| | Fluorene | mg/kg | 3,670 | N |
| | Hexachlorobenzene ^c | mg/kg | 1.2 | C |
| | Indeno(1,2,3-cd)pyrene | mg/kg | 2.34 | C |
| | Naphthalene | mg/kg | 17.4 | C |
| | Nitrobenzene | mg/kg | 15.1 | C |
| | Octachlorostyrene | mg/kg | -- | -- |
| | Phenanthrene | mg/kg | 24.5 | sat |
| | Pyrene | mg/kg | 19,300 | N |
| Pyridine | mg/kg | 667 | N | |
| VOCs | 1,1,1,2-Tetrachloroethane | mg/kg | 20.3 | C |
| | 1,1,1-Trichloroethane | mg/kg | 1,390 | sat |
| | 1,1,2,2-Tetrachloroethane | mg/kg | 2.59 | C |
| | 1,1,2-Trichloroethane | mg/kg | 5.8 | C |
| | 1,1-Dichloroethane | mg/kg | 23.3 | C |
| | 1,1-Dichloroethene | mg/kg | 1,400 | N |
| | 1,1-Dichloropropene | mg/kg | -- | -- |
| | 1,2,3-Trichlorobenzene | mg/kg | -- | -- |
| | 1,2,3-Trichloropropane | mg/kg | 0.106 | C |
| | 1,2,4-Trichlorobenzene | mg/kg | 759 | N |
| | 1,2,4-Trimethylbenzene | mg/kg | 671 | N |
| | 1,2-Dibromo-3-chloropropane | mg/kg | 0.0583 | C |
| | 1,2-Dichlorobenzene | mg/kg | 373 | Sat |
| | 1,2-Dichloroethane | mg/kg | 2.41 | C |
| | 1,2-Dichloropropane | mg/kg | 4.54 | C |
| | 1,3,5-Trimethylbenzene | mg/kg | 254 | sat |
| | 1,3-Dichlorobenzene | mg/kg | 373 | Sat |

**TABLE B-1. SOIL REMEDIATION GOALS (SRGs)
Nevada Environmental Response Trust Site; Henderson, Nevada**

| PARAMETER OF INTEREST | CHEMICAL | UNIT | NDEP 2011 WORKER BCL ^a OR SITE-SPECIFIC SCREENING LEVEL | BASIS |
|-----------------------|----------------------------|-------|--|-------|
| VOCs | 1,3-Dichloropropane | mg/kg | 71.6 | N |
| | 1,4-Dichlorobenzene | mg/kg | 14.3 | C |
| | 2,2-Dichloropropane | mg/kg | -- | -- |
| | 2-Butanone | mg/kg | 34,100 | sat |
| | 2-Chlorotoluene | mg/kg | 511 | sat |
| | 2-Hexanone | mg/kg | 2,150 | N |
| | 2-Methoxy-2-methyl-butane | mg/kg | -- | -- |
| | 4-Chlorotoluene | mg/kg | -- | -- |
| | 4-Isopropyltoluene | mg/kg | 647 | Sat |
| | 4-Methyl-2-pentanone | mg/kg | 17,200 | Sat |
| | Acetone | mg/kg | 100,000 | Max |
| | Benzene | mg/kg | 4.5 | C |
| | Bromobenzene | mg/kg | 695 | N |
| | Bromochloromethane | mg/kg | -- | -- |
| | Bromodichloromethane | mg/kg | 51.3 | C |
| | Bromoform | mg/kg | 242 | C |
| | Bromomethane | mg/kg | 42.9 | N |
| | Carbon tetrachloride | mg/kg | 4.07 | C |
| | Chlorobenzene | mg/kg | 695 | Sat |
| | Chloroethane | mg/kg | 1,100 | C |
| | Chloroform | mg/kg | 1.71 | C |
| | Chloromethane | mg/kg | 8.95 | C |
| | cis-1,2-Dichloroethene | mg/kg | 791 | N |
| | cis-1,3-Dichloropropene | mg/kg | -- | -- |
| | Dibromochloromethane | mg/kg | 6.15 | C |
| | Dibromomethane | mg/kg | 210 | N |
| | Dichlorodifluoromethane | mg/kg | 340 | Sat |
| | Ethyl t-butyl ether | mg/kg | -- | -- |
| | Ethylbenzene | mg/kg | 21 | C |
| | Ethylene dibromide | mg/kg | 0.185 | C |
| | Hexachlorobutadiene | mg/kg | 24.6 | C |
| | Isopropyl ether | mg/kg | -- | -- |
| | Isopropylbenzene | mg/kg | 647 | Sat |
| | m p-Xylene | mg/kg | 214 | Sat |
| | Methyl tert butyl ether | mg/kg | 216 | C |
| | Methylene chloride | mg/kg | 60.4 | C |
| | Naphthalene | mg/kg | 17.4 | C |
| | N-Butylbenzene | mg/kg | 237 | Sat |
| | N-Propylbenzene | mg/kg | 237 | Sat |
| | o-Xylene | mg/kg | 282 | Sat |
| | sec-Butylbenzene | mg/kg | 223 | Sat |
| | Styrene | mg/kg | 1,730 | Sat |
| | t-Butyl alcohol | mg/kg | 21,300 | Sat |
| | tert-Butylbenzene | mg/kg | 393 | Sat |
| | Tetrachloroethene | mg/kg | 3.28 | C |
| | Toluene | mg/kg | 521 | Sat |
| | trans-1,2-Dichloroethylene | mg/kg | 600 | N |
| | trans-1,3-Dichloropropene | mg/kg | -- | -- |
| | Trichloroethene | mg/kg | 5.49 | C |
| | Trichlorofluoromethane | mg/kg | 1,980 | Sat |

**TABLE B-1. SOIL REMEDIATION GOALS (SRGs)
Nevada Environmental Response Trust Site; Henderson, Nevada**

| PARAMETER OF INTEREST | CHEMICAL | UNIT | NDEP 2011 WORKER BCL ^a OR SITE-SPECIFIC SCREENING LEVEL | BASIS |
|------------------------|------------------------------|--------------------------|--|------------------------|
| VOCs | Vinyl Chloride | mg/kg | 1.86 | C |
| | Xylenes, total | mg/kg | 214 | Sat |
| TPH | Oil Range Organics (TPH-oil) | mg/kg | 100 ^d | -- |
| | TPH-d | mg/kg | 100 ^d | -- |
| | TPH-g | mg/kg | 100 ^d | -- |
| PCBs | Aroclor-1016 | mg/kg | 23.6 | C |
| | Aroclor-1221 | mg/kg | 0.826 | C |
| | Aroclor-1232 | mg/kg | 0.826 | C |
| | Aroclor-1242 | mg/kg | 0.826 | C |
| | Aroclor-1248 | mg/kg | 0.826 | C |
| | Aroclor-1254 | mg/kg | 0.826 | C |
| | Aroclor-1260 | mg/kg | 0.826 | C |
| | Total PCBs | mg/kg | 0.826 | C |
| | TCDD TEQ ^e | pg/g | 2,700 ^f | C |
| General Chemistry | Cyanide | mg/kg | 13,700 | N |
| | Perchlorate | mg/kg | 795 | N |
| Dioxins/Furans | TCDD TEQ ^g | pg/g | 2,700 ^f | C |
| Metals | Aluminum | mg/kg | 100,000 | Max |
| | Antimony | mg/kg | 454 | N |
| | Arsenic | mg/kg | 7.2 ^h | -- |
| | Barium | mg/kg | 100,000 | Max |
| | Beryllium | mg/kg | 2,230 | N |
| | Boron | mg/kg | 100,000 | Max |
| | Cadmium | mg/kg | 560 | N |
| | Chromium (III) | mg/kg | 100,000 | Max |
| | Chromium (VI) | mg/kg | 1,360 | C |
| | Cobalt | mg/kg | 337 | N |
| | Copper | mg/kg | 42,200 | N |
| | Iron | mg/kg | 100,000 | Max |
| | Lead | mg/kg | 800 ⁱ | -- |
| | Magnesium | mg/kg | 100,000 | Max |
| | Manganese | mg/kg | 100,000 | Max |
| | Mercury | mg/kg | 182 | N |
| | Molybdenum | mg/kg | 5,680 | N |
| | Nickel | mg/kg | 21,800 | N |
| | Platinum | mg/kg | -- | -- |
| | Potassium | mg/kg | -- | -- |
| | Selenium | mg/kg | 5,680 | N |
| | Silver | mg/kg | 5,680 | N |
| | Sodium | mg/kg | -- | -- |
| | Strontium | mg/kg | 100,000 | Max |
| | Thallium | mg/kg | 79.5 ^j | -- |
| | Tin | mg/kg | 100,000 | Max |
| | Titanium | mg/kg | 100,000 | Max |
| | Tungsten | mg/kg | 8,510 | N |
| | Uranium | mg/kg | 3,400 | N |
| | Vanadium | mg/kg | 5,680 | N |
| | Zinc | mg/kg | 100,000 | Max |
| | Asbestos | Long amphibole fibers | fibers | 1 or more ^j |
| Long chrysotile fibers | | More than 5 ^j | | |

**TABLE B-1. SOIL REMEDIATION GOALS (SRGs)
Nevada Environmental Response Trust Site; Henderson, Nevada**

Notes:

- a = From User's Guide and Background Technical Document for Nevada Division of Environmental Protection (NDEP) Basic Comparison Levels (BCLs) for Human Health for the BMI Complex and Common Areas, Revision 6, January 2011 (<http://ndep.nv.gov/bmi/technical.htm>). Values listed are for the outdoor industrial/commercial worker.
- b = BCL based on mixed isomer.
- c = Hexachlorobenzene analyzed using both EPA Methods 8081 and 8270. Data reported based on EPA 8270 as it was deemed to be the superior method.
- d = 100 mg/kg total TPH value used for screening.
- e = TCDD equivalents based on WHO 2005 TEFs for the 12 co-planer PCBs; the detection limit was used for non-detect values.
- f = Site-specific value.
- g = TCDD equivalents based on WHO 2005 TEFs for the 17 dioxin and furan congeners.
- h = Based on regional background concentrations.
- i = A basis for the lead and thallium BCLs are not identified by NDEP.
- j = Site-specific value.
- C = Cancer
- N = Noncancer
- Sat = soil saturation
- Max = risk-based value is greater than 100,000 mg/kg
- = undefined

Appendix C

Background Data Set for Soils

Contents

| | | |
|----------|--------------------------------------|----------|
| C | Soil Background Data Sets | 1 |
| C.1 | RZ-A Background Data Set | 1 |
| C.2 | McCullough Range Background Data Set | 3 |
| C.2.1 | BRC/TIMET Background Data Set | 3 |
| C.2.2 | ENVIRON Background Data Set | 3 |
| C.3 | Summary and Conclusions | 4 |
| C.4 | Bibliography | 5 |

List of Tables

| | |
|-----------|---|
| Table C-1 | RZ-A Background Metal Concentrations for Shallow Soils |
| Table C-2 | McCullough Range Background Radionuclide Concentrations |

C Soil Background Data Sets

This appendix describes the data sets that will be used for evaluating Site concentrations relative to background conditions for purposes of evaluating nature and extent of contamination and for identifying chemicals of potential concern for the Baseline Health Risk Assessment (BHRA). The Nevada Division of Environmental Protection (NDEP) has previously approved for background evaluations, the following two background data sets: (1) soil data from Remediation Zone A (RZ-A) presented in the *Technical Memorandum: Background Comparison for Metals in Remediation Zones B through E, Compared to Remediation Zone A*, (Northgate 2010b), and (2) soil data from the McCullough Range and presented in *Background Shallow Soil Summary Report, BMI Complex and Common Area Vicinity* (Basic Remediation Company and Titanium Metals Corporation [BRC/TIMET] 2007).

As stated in NDEP's August 17, 2010, *Response to Background Issues and Determination of Background Dataset for Tronox* (NDEP 2010a), NDEP has investigated the differences between the data for metals from the RZ-A area and the McCullough Range background samples collected by BRC/TIMET in 2005. (The Black Mountain Industrial (BMI) Complex and Common Areas are located approximately 1 mile north of the McCullough Range, and the northern McCullough Range is the primary source of materials upslope of the BMI Complex [BRC/TIMET 2007]). NDEP has noted that the laboratories that analyzed the samples used various digestion methods that appear to have affected the reported metals results. Further, NDEP observed that not all of the metals analyzed reacted in the same way to the differences in digestion methods and that some of the observed differences between the two data sets may not be due to differences in the digestion method variations. Additionally, there may be other reasons for the observed differences between the data sets (e.g. geologic) that had not been investigated in detail. Based on the observed results and lack of other rationale or investigation, and to further reduce potential for unacceptable exposure to soil contamination, NDEP determined that the RZ-A dataset is appropriate for background comparisons regardless of the laboratory used for analysis.

Based on NDEP's determination, Site soil data for metals will initially be compared with the RZ-A background data set to identify metals and other naturally-occurring constituents above background levels. Depending on the purpose of the background evaluation, metals with concentrations above RZ-A background levels, may be compared to the McCullough Range data set to evaluate the levels within a regional background context. Site soil data for radionuclides will be compared against the BRC/TIMET data set.

The following sections describe the available background soil data sets for the 0 to 10 foot (ft) depth interval.

C.1 RZ-A Background Data Set

For the evaluation of metals for risk assessment purposes, NDEP has requested that the analytical results for RZ-A soils be used as the background data set for comparisons with Site concentrations (NDEP 2010a). The RZ-A soils were collected in November 2006 during the Phase A soil investigation (ENSR 2007) and from June 2008 through November 2009 as part of the Area IV Phase B soil investigation (ENSR 2008). The samples from the Phase A

investigation were analyzed in accordance with the *Phase A Source Area Investigation Work Plan* (ENSR 2006), and the samples from the Phase B investigation were analyzed in accordance with the *Revised Phase B Investigation Work Plan* (AECOM 2008) and the *Revised Phase B Quality Assurance Project Plan, Tronox LLC Facility* (AECOM and Northgate 2009). The samples were evaluated for use as a background data set for the Site in Northgate's *Technical Memorandum: Background Comparison for Metals in Remediation Zones B through E, Compared to Remediation Zone A*, submitted to NDEP on July 22, 2010 (Northgate 2010b); NDEP commented on August 9, 2010 stating that their comments should be incorporated into the HRA(s) prepared for the Site (NDEP 2010b).

Northgate (2010b) separated the RZ-A background data set into three depth intervals (shallow, middle, and deep) and two lithologic units (alluvium and Upper Muddy Creek formation) for comparisons with data collected in RZ-B through RZ-E. The shallow interval is from 0 to 10 feet (ft) below ground surface (bgs) and includes both a 0.5 ft bgs and 10 ft bgs sample. For some chemicals, the shallow interval was further divided into two intervals from 0 to 2 ft bgs and 2 to 10 ft bgs, based on a chemical-specific statistical comparison between the 0.5 ft and 10 ft samples. If this comparison showed that the 0.5 ft bgs and 10 ft bgs samples were consistent with each other, they were grouped into one shallow depth interval (0-10 ft bgs). Otherwise, these samples were separated into two intervals (0-2 and 2-10 ft bgs) for comparison to the other RZs. The metals for which the shallow interval was split into two intervals are: arsenic, chromium (total), magnesium, mercury, molybdenum, potassium, sodium, strontium, and uranium. The middle depth interval includes samples from 10 ft bgs to the top of the Upper Muddy Creek Formation (UMCf) and the deep depth interval includes samples from the UMCf.

Northgate found that one Phase A soil boring (SA02) and five Phase B soil borings (RSAU4, RSAU5, SA28, SA146, and SA147) were located in a boron source area (the former State Industries, Inc. site) in Letter of Understanding (LOU) 62 and contributed to elevated concentrations of boron and other metals, including barium, iron, and sodium. Comparisons of maximum and means from these six borings to the remaining RZ-A data showed differences between the two data sets. Therefore, the data associated with these six borings were removed from the RZ-A data set. As shown in Table C-1, the final "RZ-A background data set" for shallow soils consists of a total of 31 samples collected from 14 borings. The sample quantitation limit (SQL) was used as the detection limit for as per NDEP *Detection Limits and Data Reporting* guidance (NDEP 2008a), and $\frac{1}{2}$ SQL was used for calculating the mean and standard deviation concentrations following *NDEP Guidance on the Development of Summary Statistics Tables at the BMI Complex and Common Areas* (NDEP 2008b). Sixteen samples were collected between 0.5 and 2 ft bgs and 15 samples were collected between 10 and 11.5 ft bgs. Primary samples and field duplicates were treated as independent samples, on the basis of a preliminary evaluation indicating that the variance of the duplicates was similar to the variance of the primary samples, consistent with NDEP guidance (NDEP 2008c). An additional 13 samples were collected from the middle depth interval and 22 samples from the deep depth interval.

C.2 McCullough Range Background Data Set

Based on NDEP's recommendation (NDEP 2009d), a subset of shallow background data identified as being from sediments derived from the McCullough Range and presented in the *Background Shallow Soil Summary Report BMI Complex and Common Areas Vicinity — Basic Remediation Company Titanium Metals Corporation Henderson, Nevada* (Basic Remediation Company and Titanium Metals Corporation [BRC/TIMET 2007]), was identified for use for the evaluation of background concentrations of radionuclides. BRC/TIMET (2007) presents the analytical data for background soil that are considered representative of background conditions at the Basic Management, Inc. (BMI) Complex, in which the Site is located, and Common Areas in Clark County, Nevada. The main objective of the report was to collect and analyze background soil samples for metals and radionuclides that can be used to evaluate whether concentrations of site-related chemicals (SRCs) detected in soil samples statistically exceed concentrations of these chemicals in background soil.

Analytical data from both the BRC/TIMET and ENVIRON (2003) studies were used in BRC/TIMET's (2007) evaluation and were incorporated in the overall "McCullough Range" background data set as discussed below and provided in Table C-2.

C.2.1 BRC/TIMET Background Data Set

BRC/TIMET collected soil samples from 33 initial sampling locations on 11 undeveloped properties near and upgradient from the BMI Complex and Common Areas. At each of the properties, soil samples were collected from three borings drilled approximately 10 to 15 ft apart. As described in the BRC/TIMET report, surface soil is defined as the upper 0.5 ft of the soil horizon and subsurface soil is defined as below 0.5 ft bgs. The BRC/TIMET data set generally consists of 104 samples analyzed for a total of 78 chemicals (43 metals and anions and 35 radionuclides).

Full validation was conducted on 10 percent of the BRC/TIMET data set, and a partial validation was conducted on the remaining 90 percent. Stable chemistry (metals and anions) results for background soil samples were validated in accordance with the USEPA guidance documents *USEPA Contract Laboratory Program National Functional Guidelines for Inorganic Data Review* (USEPA 2004a) and *Region 9 Superfund Data Evaluation/Validation Guidance* (USEPA 2001). In the absence of a standardized process for the validation of radionuclide data, the reviewer relied on professional judgment and other sources for data qualification. Radionuclide data validation was conducted using several documents, including the USEPA document *Multi-Agency Radiological Laboratory Analytical Protocols Manual (MARLAP)* (USEPA 2004b), the United States Department of Energy (USDOE) reference document titled *Evaluation of Radiochemical Data Usability* (USDOE 1997), and quality control requirements and criteria summarized in the applicable methods.

C.2.2 ENVIRON Background Data Set

ENVIRON collected soil samples from eight borings from the City of Henderson. Samples were collected from 0 to 1 and from 3 to 4 ft bgs. The ENVIRON dataset generally consists of 16 samples analyzed for a total of 38 chemicals (23 metals and anions and 15 radionuclides).

A partial validation was conducted on the entire ENVIRON data set by Neptune and Company, NDEP's consultant. Stable chemistry sample results for the ENVIRON background soil samples were validated in accordance with USEPA (2004a). Professional judgment and analytical method requirements were used to validate radionuclides data. Based on data validation and review, Neptune concluded that the validated ENVIRON data set is suitable for inclusion in the overall BRC/TIMET background data set with the provision that results for hexavalent chromium, radium-224, radium-226, and radium-228 are excluded due to analytical considerations (BRC/TIMET 2007).

C.3 Summary and Conclusions

Consistent with direction from NDEP, analytical results for metals in soils will be compared with the RZ-A background data and radionuclides will be compared with the McCullough Range data set. The McCullough Range data set will be used for metals to provide regional context to the concentrations. For radionuclides, Site soil data will be compared against the BRC/TIMET data set.

C.4 Bibliography

- AECOM, Inc. (AECOM), 2008. Revised Phase B Site Investigation Work Plan for Areas I, II, III and IV, Tronox LLC Facility, Henderson, Nevada, December. NDEP approved Response to Comments (dated January 16, 2009) January 16, 2009.
- AECOM and Northgate Environmental Management, Inc. (Northgate), 2009. Revised Phase B Quality Assurance Project Plan Tronox LLC Facility, Henderson, Nevada (QAPP). Revision, July. NDEP approved January 16, 2009.
- Basic Remediation Company and Titanium Metals Corporation (BRC/TIMET). 2007. Background Shallow Soil Summary Report, BMI Complex and Common Areas Vicinity. March 16.
- ENSR Corporation (ENSR), 2006. Phase A Source Area Investigation Work Plan, Tronox LLC Facility, Henderson, Nevada. September. NDEP conditionally approved October 26, 2006.
- ENSR, 2007. Phase A Source Area Investigation Results, Tronox Facility, Henderson, Nevada. September. NDEP approved November 30, 2007.
- ENSR. 2008. Phase B Source Area Investigation Work Plan Area IV (Western and Southern LOUs). Tronox LLC Facility, Henderson, Nevada. May. NDEP conditionally approved June 18, 2008.
- ENVIRON International Corporation (ENVIRON), 2003. Risk Assessment for the Water Reclamation Facility Expansion Site, Henderson, Nevada. Prepared for the City of Henderson, Nevada. October.
- ENVIRON, 2012. Baseline Health Risk Assessment Work Plan. *In preparation.*
- Nevada Division of Environmental Protection (NDEP), 2008a. Detection Limits and Data Reporting, BMI Plant Sites and Common Areas Projects, Henderson, Nevada. December 3.
- NDEP, 2008b. Guidance on the Development of Summary Statistic Tables at the BMI Complex and Common Areas in Henderson, Nevada. December 10.
- NDEP, 2008c. Statistical Analysis Recommendations for Field Duplicates and Field Splits, November 18.
- NDEP, 2009a. Technical Guidance for Evaluating Radionuclide Data for the BMI Plant Sites and Common Areas Projects, Henderson, Nevada, prepared by Neptune and Company Inc, 8550 W. 14th Avenue, Lakewood, CO for the Nevada Division of Environmental Protection, Bureau of Corrective Actions, Special Projects Branch, 2030 East Flamingo Rd, Suite 230, Las Vegas, NV 89119.
- NDEP, 2009b. Guidance for Evaluating Secular Equilibrium at the BMI Complex and Common Areas. February 6.
- NDEP, 2009c. Supplement to the Guidance for Evaluating Radionuclide Data for the BMI Plant Sites and Common Area Projects dated February 6, 2009. BMI Plant Sites and Common Area Projects, Henderson, Nevada. April 29.

NDEP. 2009d. Meeting Minutes: October 7, 2009 NDEP-TRONOX Phase B Area I Meeting. October 7.

NDEP. 2009a. User's Guide and Background Technical Document for Nevada Division of Environmental Protection (NDEP) Basic Comparison Levels (BCLs) for Human Health for the BMI Complex and Common Areas. Revision 4-November.

NDEP, 2010a. NDEP Response to Background Issues and Determination of Background Dataset for TRX. August 17.

NDEP, 2010b. NDEP Nevada Division of Environmental Protection (NDEP) Response to: Technical Memorandum: Background Comparisons for Metals in Remediation Zones B through E, Compared to Remediation Zone A, Dated: July 22, 2010. August 9.

Northgate, 2010a. Health Risk Assessment Work Plan, Tronox LLC Facility, Henderson, Nevada. March 9.

Northgate, 2010b. Technical Memorandum: Background Comparison for Metals in Remediation Zones B through E, Compared to Remediation Zone A, July 22. NDEP commented on August 9, 2010.

U.S. Department of Energy (USDOE), 1997. "Evaluation of Radiochemical Data Usability." Office of Environmental Management. Oak Ridge, Tennessee. April.

U.S. Environmental Protection Agency (USEPA), 1989. Risk Assessment Guidance for Superfund: Volume I—Human Health Evaluation Manual (Part A). Interim Final. Office of Emergency and Remedial Response, Washington, D.C. USEPA/540/1-89/002. December.

USEPA. 1992b. Guidance for Data Usability in Risk Assessment. Part A. Office of Emergency and Remedial Response, Washington D.C. Publication 9285.7-09A. PB92-963356. April.

USEPA. 1992c. Guidance for Data Usability in Risk Assessment. Part B. Office of Emergency.

USEPA. 2001. Region 9 Superfund Data Evaluation/Validation Guidance." Draft. R9QA/006.1. Quality Assurance Office. San Francisco, CA. December.

USEPA. 2002. Guidance for Comparing Background and Chemical Concentrations in Soil for CERCLA Sites. Office of Emergency and Remedial Response, Washington, DC. EPA 540-R-01-003. September.

USEPA, 2004a. USEPA Contract Laboratory Program National Functional Guidelines for Inorganic Data Review." EPA 540/R-04/004. OSWER. Washington, DC. October.

USEPA, 2004b. "Multi-Agency Radiological Laboratory Analytical Protocols Manual (MARLAP)." EPA 402-B-04-001A. Washington, DC. July.

**TABLE C-1. RZ-A BACKGROUND METAL CONCENTRATIONS FOR SHALLOW SOILS
Nevada Environmental Response Trust Site; Henderson, Nevada**

| CHEMICAL | UNIT | DEPTH INTERVAL (feet bgs) ^[1] | NUMBER OF DETECTS | TOTAL SAMPLES | % DETECTS | MINIMUM ND ^[2] | MAXIMUM ND ^[2] | MINIMUM DETECT | MAXIMUM DETECT | MEDIAN DETECT | MEAN DETECT ^[3] | STANDARD DEVIATION ^[3] |
|------------------|-------|--|-------------------|---------------|-----------|---------------------------|---------------------------|----------------|----------------|---------------|----------------------------|-----------------------------------|
| Aluminum | mg/kg | 0 - 10 | 31 | 31 | 100% | NA | NA | 7340 | 11400 | 8970 | 9020 | 890 |
| Antimony | mg/kg | 0 - 10 | 3 | 31 | 10% | 0.50 | 2.20 | 0.6 | 3.4 | 0.9 | 0.644 | 0.636 |
| Arsenic | mg/kg | 0 - 2 | 16 | 16 | 100% | NA | NA | 1.6 | 4.25 | 2 | 2.19 | 0.645 |
| Arsenic | mg/kg | 2 - 10 | 15 | 15 | 100% | NA | NA | 2.05 | 3.13 | 2.54 | 2.59 | 0.321 |
| Barium | mg/kg | 0 - 10 | 31 | 31 | 100% | NA | NA | 111 | 213 | 162 | 166 | 22.4 |
| Beryllium | mg/kg | 0 - 10 | 31 | 31 | 100% | NA | NA | 0.362 | 0.588 | 0.459 | 0.464 | 0.0475 |
| Boron | mg/kg | 0 - 10 | 7 | 31 | 23% | 10.20 | 11.00 | 3.6 | 11.7 | 6.2 | 5.59 | 1.34 |
| Cadmium | mg/kg | 0 - 10 | 25 | 31 | 81% | 0.04 | 0.04 | 0.11 | 0.48 | 0.19 | 0.163 | 0.104 |
| Chromium (Total) | mg/kg | 0 - 2 | 16 | 16 | 100% | NA | NA | 5.57 | 8.63 | 7.24 | 7.11 | 0.718 |
| Chromium (Total) | mg/kg | 2 - 10 | 15 | 15 | 100% | NA | NA | 5.6 | 10.7 | 8.12 | 8.43 | 1.23 |
| Chromium (VI) | mg/kg | 0 - 10 | 1 | 31 | 3% | 0.18 | 0.24 | 0.29 | 0.29 | 0.29 | 0.102 | 0.0352 |
| Cobalt | mg/kg | 0 - 10 | 31 | 31 | 100% | NA | NA | 5.4 | 9.1 | 7.3 | 7.34 | 0.758 |
| Copper | mg/kg | 0 - 10 | 31 | 31 | 100% | NA | NA | 15.8 | 140 | 19.1 | 23.1 | 21.8 |
| Iron | mg/kg | 0 - 10 | 31 | 31 | 100% | NA | NA | 11300 | 20600 | 15700 | 15500 | 2140 |
| Lead | mg/kg | 0 - 10 | 31 | 31 | 100% | NA | NA | 7.1 | 72.8 | 8.9 | 11.3 | 11.6 |
| Magnesium | mg/kg | 0 - 2 | 16 | 16 | 100% | NA | NA | 7700 | 11500 | 9120 | 9300 | 1110 |
| Magnesium | mg/kg | 2 - 10 | 15 | 15 | 100% | NA | NA | 9230 | 13000 | 10500 | 10700 | 1140 |
| Manganese | mg/kg | 0 - 10 | 31 | 31 | 100% | NA | NA | 262 | 537 | 360 | 366 | 61.3 |
| Mercury | mg/kg | 0 - 2 | 16 | 16 | 100% | NA | NA | 0.012 | 0.362 | 0.0175 | 0.0479 | 0.0871 |
| Mercury | mg/kg | 2 - 10 | 11 | 15 | 73% | 0.02 | 0.02 | 0.006 | 0.094 | 0.012 | 0.0165 | 0.0216 |
| Molybdenum | mg/kg | 0 - 2 | 15 | 16 | 94% | 0.31 | 0.31 | 0.31 | 32.7 | 0.43 | 2.41 | 8.08 |
| Molybdenum | mg/kg | 2 - 10 | 15 | 15 | 100% | NA | NA | 0.34 | 2.83 | 0.6 | 0.791 | 0.603 |
| Nickel | mg/kg | 0 - 10 | 31 | 31 | 100% | NA | NA | 12.7 | 21.4 | 15.6 | 15.9 | 1.78 |
| Platinum | mg/kg | 0 - 10 | 19 | 31 | 61% | 0.10 | 0.11 | 0.006 | 0.046 | 0.01 | 0.0278 | 0.0214 |
| Potassium | mg/kg | 0 - 2 | 16 | 16 | 100% | NA | NA | 1830 | 4210 | 2280 | 2510 | 726 |
| Potassium | mg/kg | 2 - 10 | 15 | 15 | 100% | NA | NA | 1450 | 2420 | 1740 | 1830 | 333 |
| Selenium | mg/kg | 0 - 10 | 3 | 31 | 10% | 0.70 | 4.30 | 0.8 | 0.9 | 0.8 | 0.576 | 0.543 |
| Silver | mg/kg | 0 - 10 | 0 | 31 | 0% | 0.20 | 0.20 | NA | NA | NA | 0.1 | 4.23E-17 |
| Sodium | mg/kg | 0 - 2 | 16 | 16 | 100% | NA | NA | 307 | 864 | 468 | 533 | 181 |
| Sodium | mg/kg | 2 - 10 | 15 | 15 | 100% | NA | NA | 474 | 1050 | 729 | 714 | 166 |
| Strontium | mg/kg | 0 - 2 | 16 | 16 | 100% | NA | NA | 129 | 299 | 186 | 189 | 46.8 |
| Strontium | mg/kg | 2 - 10 | 15 | 15 | 100% | NA | NA | 177 | 339 | 255 | 257 | 45.3 |
| Thallium | mg/kg | 0 - 10 | 31 | 31 | 100% | NA | NA | 0.071 | 0.193 | 0.092 | 0.107 | 0.0329 |
| Tin | mg/kg | 0 - 10 | 0 | 31 | 0% | 10.20 | 11.00 | NA | NA | NA | 5.28 | 0.0831 |
| Titanium | mg/kg | 0 - 10 | 31 | 31 | 100% | NA | NA | 480 | 1080 | 829 | 793 | 162 |
| Tungsten | mg/kg | 0 - 10 | 30 | 31 | 97% | 0.11 | 0.11 | 0.12 | 0.62 | 0.17 | 0.209 | 0.111 |
| Uranium | mg/kg | 0 - 2 | 16 | 16 | 100% | NA | NA | 0.655 | 1.01 | 0.829 | 0.817 | 0.116 |
| Uranium | mg/kg | 2 - 10 | 15 | 15 | 100% | NA | NA | 0.913 | 1.94 | 1.34 | 1.34 | 0.332 |
| Vanadium | mg/kg | 0 - 10 | 31 | 31 | 100% | NA | NA | 28 | 54.9 | 46 | 43.8 | 7.58 |
| Zinc | mg/kg | 0 - 10 | 31 | 31 | 100% | NA | NA | 25.8 | 254 | 33.3 | 40.4 | 39.9 |

Notes:

Background dataset is from RZ-A, excluding the 6 borings in LOU 62 as described in Section C.1.

[1] Depth Intervals (measured from ground surface to the top of samples):

0 - 2 = 0 feet below ground surface (bgs) to 2 feet bgs

2 - 10 = greater than 2 feet bgs to 10 feet bgs

0 - 10 = 0 feet bgs to 10 feet bgs

[2] The SQL was used as the detection limit following NDEP guidance (NDEP 2008a).

[3] The mean and standard deviation were calculated using one half of the SQL following NDEP guidance (NDEP 2008b).

**TABLE C-1. RZ-A BACKGROUND METAL CONCENTRATIONS FOR SHALLOW SOILS
Nevada Environmental Response Trust Site; Henderson, Nevada**

Abbreviations:

bgs = below ground surface

mg/kg = milligrams per kilogram

NA = value not available

NDEP = Nevada Division of Environmental Protection

SQL = sample quantitation limit

References:

Nevada Division of Environmental Protection (NDEP), 2008a. Detection Limits and Data Reporting, BMI Plant Sites and Common Areas Projects, Henderson, Nevada. December 3.

NDEP, 2008b. Guidance on the Development of Summary Statistic Tables at the BMI Complex and Common Areas in Henderson, Nevada. December 10.

**TABLE C-2. McCullough Range Background Radionuclide Concentrations
Nevada Environmental Response Trust Site; Henderson, Nevada**

| CHEMICAL | DEPTH INTERVAL | NUMBER OF DETECTS | TOTAL SAMPLES | % DETECTS | MINIMUM CONCENTRATION | MAXIMUM CONCENTRATION | MEDIAN CONCENTRATION | MEAN CONCENTRATION | STANDARD DEVIATION |
|----------|----------------|-------------------|---------------|-----------|-----------------------|-----------------------|----------------------|--------------------|--------------------|
| Th-232 | 0 - 10 | 101 | 101 | 100% | 1.22 | 2.23 | 1.66 | 1.66 | 0.255 |
| Ra-228 | 0 - 10 | 81 | 81 | 100% | 0.946 | 2.92 | 1.93 | 1.89 | 0.39 |
| Th-228 | 0 - 10 | 101 | 101 | 100% | 1.15 | 2.28 | 1.78 | 1.74 | 0.262 |
| U-235 | 0 - 6 | 71 | 71 | 100% | 0.042 | 0.13 | 0.081 | 0.0809 | 0.0286 |
| U-235 | 6 - 10 | 30 | 30 | 100% | 0.037 | 0.21 | 0.1 | 0.111 | 0.047 |
| U-238 | 0 - 6 | 71 | 71 | 100% | 0.65 | 1.95 | 1.01 | 1.03 | 0.227 |
| U-238 | 6 - 10 | 30 | 30 | 100% | 0.85 | 2.37 | 1.39 | 1.46 | 0.432 |
| U-234 | 0 - 6 | 71 | 71 | 100% | 0.63 | 2.44 | 0.98 | 1.03 | 0.288 |
| U-234 | 6 - 10 | 30 | 30 | 100% | 0.85 | 2.84 | 1.34 | 1.55 | 0.566 |
| Th-230 | 0 - 6 | 71 | 71 | 100% | 0.73 | 2.44 | 1.18 | 1.19 | 0.276 |
| Th-230 | 6 - 10 | 30 | 30 | 100% | 0.81 | 3.01 | 1.56 | 1.54 | 0.498 |
| Ra-226 | 0 - 6 | 65 | 65 | 100% | 0.494 | 1.82 | 1.06 | 1.07 | 0.244 |
| Ra-226 | 6 - 10 | 30 | 30 | 100% | 0.507 | 2.36 | 1.25 | 1.33 | 0.442 |

Notes:

Background dataset is from BRC/TIMET's (2007) McCullough Range dataset.

The summary statistic tables that will be presented in the Baseline Health Risk Assessment (ENVIRON 2012) will be revised in accordance with NDEP guidance (NDEP 2008b).

[1] Depth Intervals (measured from ground surface to the top of samples):

0 - 6 = 0 feet below ground surface (bgs) to 6 feet bgs

6 - 10 = greater than 6 feet bgs to 10 feet bgs

0 - 10 = 0 feet bgs to 10 feet bgs

Abbreviations:

bgs = below ground surface

BRC = Basic Remediation Company

ENVIRON = ENVIRON International Corporation

NDEP = Nevada Division of Environmental Protection

TIMET = Titanium Metals Corporation

References:

Basic Remediation Company and Titanium Metals Corporation (BRC/TIMET). 2007. Background Shallow Soil Summary Report, BMI Complex and Common Areas Vicinity. March 16.

ENVIRON International Corporation (ENVIRON), 2012. Baseline Health Risk Assessment. In preparation.

Nevada Division of Environmental Protection (NDEP), 2008b. Guidance on the Development of Summary Statistic Tables at the BMI Complex and Common Areas in Nevada. December 10.

Appendix D
PRB Treatability and Bench Scale
Test Study Work Plan



**Treatability Study Work Plan
Permeable Reactive Barrier Pilot
Nevada Environmental Response Trust Site,
Henderson, Nevada**

Prepared for:
Nevada Environmental Response Trust

Prepared by:
**ENVIRON International Corporation
Chicago, Illinois**

Date:
December 17, 2012

Project Number:
21-29100H H06



Treatability Study Work Plan Permeable Reactive Barrier Pilot

**Nevada Environmental Response Trust
(Former Tronox LLC Site)
Henderson, Nevada**

Nevada Environmental Response Trust (NERT) Representative Certification

I certify that this document and all attachments submitted to the Division were prepared at the request of, or under the direction or supervision of the Trust. Based on my own involvement and/or my inquiry of the person or persons who manage the system(s) or those directly responsible for gathering the information or prepared the document, or the immediate supervisor of such person(s), the information submitted and provided herein is, to the best of my knowledge and belief, true, accurate, and complete in all material respects.

Le Petomane XXVII, Inc., not individually, but solely in its representative capacity as the Nevada Environmental Response Trust Trustee

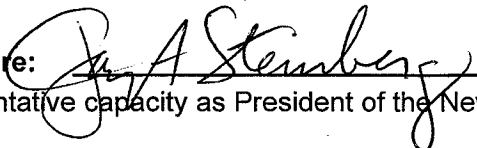
Signature: , not individually, but solely in his representative capacity as President of the Nevada Environmental Response Trust Trustee

Name: Jay A. Steinberg, not individually, but solely in his representative capacity as President of the Nevada Environmental Response Trust Trustee

Title: Solely as President and not individually

Company: Le Petomane XXVII, Inc., not individually, but solely in its representative capacity as the Nevada Environmental Response Trust Trustee

Date: 12/14/12

Contents

| | Page |
|--|-------------|
| 1 Introduction | 1 |
| 1.1 Background and Regulatory Status | 1 |
| 1.1.1 Groundwater Contamination | 1 |
| 1.2 Work Plan Organization | 2 |
| 2 Purpose and Objectives | 2 |
| 2.1 Purpose | 2 |
| 2.2 Objectives | 2 |
| 2.2.1 Bench Study Objectives | 2 |
| 2.2.2 Field-Scale Pilot Objectives | 2 |
| 2.3 Work Performed By Others | 3 |
| 3 Site Conditions | 4 |
| 3.1 Geology | 4 |
| 3.2 Hydrology | 4 |
| 3.3 Groundwater Quality | 5 |
| 4 Technology Overview and Rationale | 6 |
| 4.1 PRB Functional Description | 6 |
| 4.2 PRB Case Study Review | 7 |
| 5 PRB Pilot Design | 8 |
| 5.1 Candidate Installation Location | 8 |
| 5.2 Preliminary Activities | 9 |
| 5.2.1 Soil Boring and Well Installation | 9 |
| 5.2.2 Groundwater Sampling and Analysis | 9 |
| 5.2.3 Management of Investigation-Derived Wastes | 10 |
| 5.3 Bench Scale Testing | 10 |
| 5.3.1 Microcosm (Serum Bottle) Testing | 11 |
| 5.3.2 Column Testing | 13 |
| 5.3.3 Establishment of Parameters for Field-Scale Design | 15 |
| 5.3.4 Reporting | 16 |
| 5.3.5 Final Design and Permitting | 16 |
| 6 Monitoring | 17 |
| 6.1 Preliminary Groundwater Monitoring Plan | 17 |
| 6.2 Monitoring Well Locations | 17 |

| | | |
|----------|-------------------|-----------|
| 7 | Schedule | 18 |
| 8 | References | 19 |

List of Figures

| | |
|-----------|--|
| Figure 1: | Site Location Map and Candidate PRB Test Location |
| Figure 2: | Proposed PRB Test Area |
| Figure 3: | Cross Section A - A' |
| Figure 4: | Cross Section B - B' |
| Figure 5: | Cross Section C - C' |
| Figure 6: | Conceptual Pilot Layout of Pilot Scale PRB |
| Figure 7: | Preliminary Time Schedule for PRB Treatability Study |

List of Tables

| | |
|----------|---|
| Table 1 | Summary of Work Performed by Others |
| Table 2: | Well Construction Details for Existing Wells, Candidate PRB Pilot Scale Test Location |
| Table 3: | Summary of Ground Water Indicator Parameters, Vicinity of Candidate Field-Scale PRB Test Location |
| Table 4: | Summary of Ground Water Quality Results (Northgate, December 2010) |
| Table 5: | Summary of Selected PRB Case Studies |
| Table 6: | Analytical Parameters for PRB Monitoring - PRB Field-Scale Pilot |

List of Appendices

| | |
|-------------|---|
| Appendix A: | Boring Logs and Well Construction Diagrams |
| Appendix B: | Standard Operating Procedures |
| Appendix C: | Research Laboratory Bench-Scale Testing Protocols |

Acronyms and Abbreviations

| | |
|----------|---|
| AWF | Athens Road Well Field |
| bgs | below ground surface |
| BMI | Black Mountain Industrial |
| COPCs | Chemicals of Potential Concern |
| DO | Dissolved oxygen |
| EDs | electron donors |
| EDD | electron donor demand |
| ENVIRON | ENVIRON International Corporation |
| ESTCP | U.S. Department of Defense, Environmental Security Technology Certification Program |
| FRTR | Federal Remediation Technologies Roundtable |
| ft | feet |
| ft/ft | feet per foot |
| GC-FID | Gas chromatograph – flame ionization |
| gpd | gallons per day |
| GWETS | Groundwater Extraction and Treatment System |
| IC-MS/MS | Ion chromatography-mass spectroscopy-mass spectroscopy |
| ITRC | Interstate Technology & Regulatory Council |
| lpm | liters per minute |
| IWF | Interceptor Well Field |
| µg/L | micrograms per liter |
| mg/L | milligrams per liter |
| mL | milliliter |
| NDWR | Nevada Division of Water Resources |
| NAC | Nevada Administrative Code |
| NDEP | Nevada Division of Environmental Protection |
| NERT | Nevada Environmental Response Trust |
| NOI | Notice of Intent |
| ORP | Oxidation-Reduction Potential |
| PID | Photoionization detector |
| PPE | Personal Protective Equipment |
| PRB | Permeable Reactive Barrier |

| | |
|--------|--|
| PVC | polyvinyl chloride |
| RAOs | Remedial Action Objectives |
| RIBs | Rapid Infiltration Basins |
| RI/FS | Remedial Investigation/Feasibility Study |
| SERDP | Strategic Environmental Research & Development Program |
| Shaw | Shaw Environmental Inc. |
| SOPs | Standard Operating Procedures |
| SWF | Seep Area Well Field |
| Tronox | Tronox, LLC |
| Trust | Nevada Environmental Response Trust |
| UIC: | Underground Injection Control |
| UMCf | Upper Muddy Creek Formation |
| USA | Underground Service Alert |
| USDW | Underground Source of Drinking Water |
| USEPA | U.S. Environmental Protection Agency |
| WBZs | water-bearing zones |

1 Introduction

ENVIRON International Corporation (ENVIRON) on behalf of the Nevada Environmental Response Trust (the Trust) has prepared this Treatability Study Work Plan for a Permeable Reactive Barrier Pilot for the Nevada Division of Environmental Protection (NDEP). This Treatability Study Work Plan provides a scope of work including bench-scale testing to enable the design of a field-scale pilot for a permeable reactive barrier (PRB) at the Nevada Environmental Response Trust Site in Clark County, Nevada (“NERT Site” or the “Site”). The Site is located approximately 13 miles southeast of the city of Las Vegas in an unincorporated area of Clark County, Nevada, within Sections 1, 12 and 13 of Township 22 S, Range 62 E. The location of the Site and the candidate PRB pilot test location are shown in Figure 1. As part of a Remedial Investigation/Feasibility Study (RI/FS), ENVIRON is currently investigating potentially feasible technologies to meet Remedial Action Objectives (RAOs) at the NERT Site. Various in-situ and ex-situ technologies are under consideration to mitigate the migration of perchlorate in groundwater. Of the technologies currently under consideration, PRBs appear to represent a particularly promising method to achieve RAOs and potentially reduce current costs of the existing Groundwater Extraction and Treatment System (GWETS). If effective, a PRB could help to reduce or potentially eliminate the need for downgradient extraction of groundwater and treatment in the GWETS as is currently performed at the NERT Site.

1.1 Background and Regulatory Status

1.1.1 Groundwater Contamination

The Site has been undergoing active remediation to manage hexavalent chromium groundwater contamination (since 1986) and perchlorate contamination of groundwater (since 1998), under consent orders issued by NDEP to the Kerr McGee Chemical Corporation. Both contaminants are treated by means of a groundwater extraction system and on-site treatment facilities, collectively referred to as the GWETS. Groundwater is collected at three well fields: the on-site Interceptor well field (IWF), the off-site Athens Road well field (AWF), and the off-site Seep Area well field (SWF). Groundwater collected from the IWF is first treated to reduce hexavalent chromium to trivalent chromium through a ferrous sulfate treatment system. After the ferrous sulfate treatment process, perchlorate is treated using perchlorate-reducing bacteria in a series of fluidized bed reactors (FBRs). Groundwater extracted from the AWF and SWF is discharged directly to the FBR process for perchlorate removal. Following treatment, groundwater is discharged to the Las Vegas Wash under a National Pollutant Discharge Elimination System (NPDES) permit.

The on-site IWF also includes a bentonite-slurry barrier wall which was constructed as a physical barrier across the higher concentration portion of the on-site perchlorate groundwater plume in 2001. The barrier is approximately 1,600 feet (ft) in length and 60 ft deep, constructed to tie into approximately 30 ft of the underlying Upper Muddy Creek Formation (UMCf).

Although the current GWETS has effectively removed substantial amounts of perchlorate (and hexavalent chromium) from groundwater, elevated concentrations persist in groundwater at the Site.

1.2 Work Plan Organization

This Work Plan relates to the proposed bench scale and field scale trials for installation of a permeable reactive barrier (PRB) and is organized as follows:

- Section 2 presents the purpose and objectives of the proposed PRB;
- Section 3 presents the Site conditions in the candidate location of the proposed PRB;
- Section 4 presents an overview of PRB technology and the rationale for the proposed PRB;
- Section 5 presents the proposed approach for design of the pilot-scale PRB, including up-front soil boring and well installation and performance of bench-scale studies, establishment of design parameters and reporting;
- Section 6 presents the monitoring to be undertaken for the proposed PRB treatability study;
- Section 7 presents the proposed schedule for the studies; and
- Section 8 details the references used in compiling this Work Plan.

Figures and tables are presented at the back of the report text, followed by the Appendices.

2 Purpose and Objectives

2.1 Purpose

As described in Section 1.2, the GWETS is currently in operation at the Site. The GWETS extracts and treats groundwater impacted with perchlorate and hexavalent chromium to control the migration of these chemicals of potential concern (COPCs) in groundwater and to limit the discharge of COPCs to the Las Vegas Wash. The purpose of this Work Plan is to evaluate the technical feasibility and overall effectiveness of an in-situ PRB in treating perchlorate to levels that will achieve RAOs for perchlorate in groundwater at the Site. To properly evaluate this technology, ENVIRON proposes to conduct bench-scale microcosm and column studies, followed by installation and operation of a field-scale pilot at the Site. The specific objectives for these studies including a summary of work done to date (by others) are provided below.

2.2 Objectives

The ultimate objective of both the bench scale tests and field scale trial is to evaluate the effectiveness of using PRB technology as a component of the ultimate remedy at the Site. The study will develop necessary information required for the design and implementation of a full scale PRB at the Site for sustained in-situ treatment of perchlorate in groundwater to meet RAOs. This will be achieved by the specific objectives presented below.

2.2.1 Bench Study Objectives

The objectives of operation of the bench-scale study are as follows:

- Using site-specific groundwater and soil cuttings, perform bench-scale testing, using microcosm jar tests and column studies, to evaluate a variety of materials and to select the appropriate amendments tailored to the Site conditions; and
- Develop the necessary parameters from the observed reaction kinetics to enable the selection of the morphology (e.g., trench PRB, injected PRB) and the sizing for design of the field-scale PRB.

2.2.2 Field-Scale Pilot Objectives

The objectives of operation of the field-scale PRB pilot are as follows:

- Determine the optimum electron donor substrate mixture and the means of delivery to groundwater (i.e., by injection or by installation of a treatment wall) considering the site-specific geology and hydrogeology to achieve degradation of perchlorate consistent with RAOs for Site groundwater;
- Evaluate the conditions in operation of the PRB to minimize the potential for biofouling;
- Determine the impact of operation of the PRB on the solubility and mobilization of metals within the aquifer; and
- Develop design parameters necessary for implementation of a full-scale PRB at the Site.

2.3 Work Performed By Others

Between 2000 and 2010, a series of studies were undertaken and plans were prepared relevant to the application of PRB technology including the following:

| Date | Type of Study or Plan | Performed by |
|-------------|--|--|
| 12/19/2000 | Hydrogeologic | Errol L. Montgomery and Associates Inc. |
| 1/18/2001 | Seep Groundwater Characterization | Kerr-McGee Chemical, LLC |
| 2/14/2010 | Work Plan for PRB Pilot Testing | Shaw Environmental, Inc. |
| 10/25/2010 | Emulsion Retention Testing and Bench-Scale Jar Testing | Northgate Environmental Management, Inc. |

A detailed summary of the work performed to date by others related to the proposed PRB pilot are summarized in Table 1.

3 Site Conditions

3.1 Geology

From review of available borehole logs (Northgate 2011) and as is described in the following, the geology of the area of the proposed PRB is comprised of the following three units: general fill, quaternary alluvium (Qal) and a Tertiary Upper Muddy Creek formation (UMCf).

- **Fill Material** is not generally present in the area of the proposed PRB, the exceptions being in borehole MW-K5 (northeastern corner of the proposed PRB area) and PC-103 (adjacent to the southwestern corner of the proposed PRB). In these areas, fill is described as a silty sand (3.5 ft thick) overlying a clayey, sandy gravel to 8 ft below ground surface (bgs) (MW-K5); and as “construction material” (taken to refer to demolition rubble) extending to 6 ft bgs (PC-103).
- **Quaternary Alluvium** is present in each of the seven locations drilled to date in the area of the proposed PRB and generally comprises a reddish-brown heterogeneous mixture of well-graded sand and gravel with lesser amounts of silt and clay. The gravel comprises the aforementioned Tertiary volcanic rocks with rare cobbles encountered (PC-98R at 29-30 ft bgs). Caliches (hardened deposits of calcium carbonate) are also known to be present in the area and were recorded as a band of gravel from 16-20 ft bgs in PC-98R. The alluvial deposits extend to between 29 and 40.5 ft bgs with thicknesses ranging between 23 and 40.5 ft. These alluvial deposits are further described as being loose and coarse (Errol L. Montgomery & Associates, 2000).

A major feature of the alluvial deposits is the stream-deposited sands and gravels that were laid down within paleochannels that were eroded into the surface of the UMCf during infrequent flood runoff periods. These deposits vary in thickness and are narrow and linear. These generally uniform sand and gravel deposits exhibit higher permeability than the adjacent, well-graded deposits. In general, these paleochannels trend northeastward (ENSR, 2006).

- **Tertiary UMCf** underlies the alluvial deposits and is comprised generally of gray/green sandy and silty clay to clayey sand with gypsum crystals which was encountered in all but one of the boreholes drilled in the proposed PRB area (the one exception being borehole I-2 drilled by Northgate as a PRB test bore in 2011 which terminated in the alluvial deposits). Referencing the available borehole logs for the proposed PRB area (Northgate, 2011), the UMCf was encountered between 29 and 40.5 ft bgs. The full thickness of the UMCf was not determined as all the boreholes drilled into it terminated within the first few feet.

Soil boring logs and well construction diagrams for wells in the vicinity of the candidate PRB location are included in Appendix A. A table of well construction details is provided in Table 2. Cross sections showing the detailed geology in the area of the proposed PRB are presented in Figures 3 to 5.

3.2 Hydrology

Depth to groundwater in the candidate PRB pilot area ranges from about 21 to 24 ft bgs. The groundwater gradient averages 0.02 ft/ft south of the AWF, flattening to 0.007 ft/ft just south of

the SWF (ENVIRON, 2011b, 2012). The groundwater flow direction at the Site is generally north to north-northwesterly. This generally uniform flow pattern may be modified locally by subsurface alluvial channels cut into the underlying UMCf, the on-site bentonite-slurry groundwater barrier wall, on- and off-site artificial groundwater highs or “mounds” created around the on-site recharge trenches and City of Henderson Water Reclamation Facility Rapid Infiltration Basins (RIBs), and by depressions created by the groundwater extraction wells at the three groundwater recovery well fields (Northgate, 2010).

As stated above in Section 2.3.1, the rate of groundwater movement in the PRB area is in the range of 30 to 45 ft/day, aquifer thickness is approximately 25 ft, transmissivity is approximately 55,000 gpd/ft and hydraulic conductivity is approximately 2,200 gpd/ft².

NDEP has defined three water-bearing zones (WBZs) that are of interest in the BMI complex: the Shallow Zone, which extends to approximately 90 ft bgs, is unconfined to partially confined, and is considered the “water table aquifer”; the Middle Zone, from approximately 90 to 300 ft bgs; and the Deep Zone, which is defined as the contiguous water-bearing zone that is generally encountered between 300 to 400 ft bgs (NDEP, 2009a). The Shallow Zone will be the focus of the PRB field pilot test.

3.3 Groundwater Quality

Within the candidate PRB pilot area, perchlorate concentrations in groundwater samples range from 3 to 18 mg/L (ENVIRON, 2011b, 2012). During the pump test of PC-98R, Errol L. Montgomery & Associates, observed the following conditions with respect to general groundwater quality parameters.

- Temperature (ranged from 23° to 24°C)
- Specific Conductivity ranged from 12,300 to 13,500 microSiemens per centimeter (µSm/cm); and
- pH ranged from 6.90 to 7.70 (Errol L. Montgomery & Associates, 2000).

Water quality analyses performed by Northgate in 2010 included dissolved metals and anionic species. The results showed a high concentration of sulfate is present in shallow groundwater at 1,400 mg/L. A summary of groundwater indicator parameters and water quality conditions in the candidate location for the field-scale PRB pilot is presented in Table 3 and Table 4.

To further establish groundwater quality in the vicinity of the proposed PRB pilot location and as is discussed further in Section 5 below, baseline groundwater sampling and analysis is proposed as part of design activities for the field-scale pilot.

4 Technology Overview and Rationale

PRB technology for the removal of perchlorate involves the creation of conditions in the subsurface environment which are conducive to the growth of biological communities that are able to use perchlorate as an electron acceptor in biological growth. The conditions required for such a reaction to occur include the presence of a suitable electron donor (or carbon source), appropriate redox potential, and the presence of other agents necessary for biological growth (e.g., trace nutrients). Specific areas of the subsurface environment where these conditions are created are referred to as reactive or treatment zones and constitute the active portion of the PRB. The treatment zones are placed in the path of groundwater flow such that perchlorate in groundwater is removed biologically as it moves through the zone. Remediation of perchlorate in groundwater at the Site using an in-situ technology such as a PRB includes the following challenges:

- High groundwater velocities (i.e., on the order of 4 to 30 ft per day)
- Natural competition in the aquifer for electron donor (i.e., electron donor demand (EDD))
- Controlling conditions (e.g., redox potential, concentration of electron donor) to limit biofouling
- Sustained long-term operation

The design of the PRB will depend upon various parameters including the characteristics of the formation, the type of amendment (i.e., electron donor) to be deployed, and the resulting time necessary to degrade perchlorate to the desired concentration in groundwater (FRTR, 2005). In addition to the amount of amendment necessary to accomplish biodegradation of perchlorate, dosing of the selected electron donor needs to account for other, abiotic processes that would consume the donor and reduce their bioavailability to degrade perchlorate (SERDP, 2009).

System design typically requires an estimate of groundwater flow, solute transport and biodegradation processes that are involved in the application of a bioremediation system. Specifically, these estimates are used to ensure that the treatment system will 1) biologically degrade perchlorate within the treatment zone, and 2) limit excess delivery of electron donor. Using electron donor biological decay rates measured in laboratory microcosm and/or column experiments, the fate and transport of injected electron donor can be estimated. Thus, electron donor delivery can be optimized to limit downgradient migration (and subsequent secondary impacts such as metals mobilization) while still providing a sufficiently large biological treatment zone, and reducing the potential for biofouling.

4.1 PRB Functional Description

PRBs typically follow two treatment strategies: passive and semi-passive. Passive PRBs include the installation of either solid electron donor material or the placement of liquid or slurry electron donor within wells screened below the groundwater table and within the desired zone of treatment within the aquifer. To prolong conditions within the PRB that promote degradation of contaminants, slow release compounds are often employed. Semi-passive PRBs deliver electron donor material by means of injection wells at either a continuous or periodic dose rate.

4.2 PRB Case Study Review

A literature review was performed to obtain currently available information on the efficacy of field-scale pilot tests and full-scale installations of PRBs for treatment of perchlorate and other similar contaminants in groundwater. Perchlorate reductions were reported in the range of 86% to 97%. Passive PRBs were successful in treating perchlorate concentrations from 170,000 micrograms per liter ($\mu\text{g/L}$) to non-detect levels. The performance of semi passive systems reviewed indicated reduction in perchlorate concentrations from a range of 2,230 to 9,000 $\mu\text{g/L}$, down to a range of non-detect to 90 $\mu\text{g/L}$. Semi passive systems have shown to be as effective as passive systems, however performance data for full-scale, long-term operation of PRBs was very limited. The reduction of perchlorate can also cause the bacteria to reduce other available constituents in the groundwater (e.g., stable metals compounds containing manganese and iron were studied and monitored for mobilization due to the stimulation of bacteria). Mobilization of iron and manganese was noted in one of the larger pilot studies performed in Rancho Cordova, California. A summary of the selected PRB case studies reviewed is presented in Table 5.

5 PRB Pilot Design

As described previously, ENVIRON proposes treatability studies at both the bench-scale and pilot-scale to gather the necessary information and to evaluate the technical feasibility and overall effectiveness of using PRB technology for the sustained treatment of perchlorate in groundwater at the Site. Specifically, ENVIRON intends to:

1. Install soil borings and monitoring wells in an area designated for the field-scale pilot while also collecting the necessary groundwater and soil cuttings to enable bench-scale testing;
2. Conduct a bench-scale test program to test the efficiency of various electron donors, establish optimal dosing rates, and to develop kinetic parameters to enable field-scale design; and
3. Complete a final design of the field-scale pilot installation at the candidate location at the Site.

5.1 Candidate Installation Location

ENVIRON is proposing to locate the field pilot test PRB in the location identified by Shaw and Northgate, i.e. approximately 2,000 ft down-gradient of the AWF, approximately mid-way between the AWF and SWF (as shown on Figure 2). The in-situ PRB will be located to intersect the flow of groundwater in the saturated alluvium overlying the UMCf. The property in the proposed installation location is owned by the City of Henderson. Arrangements for access for installation and monitoring of the field-scale PRB will be required.

This candidate location has been proposed based on the following:

- The area is far enough from the extraction well fields, such that the injected substrate will not be affected by pumping gradients;
- The area is located within the paleochannels in the UMCf which appear to influence the direction of groundwater flow from the Site and transport of perchlorate from the Site to the Las Vegas Wash (refer to cross sections on Figures 3 to 5, and Section 3);
- Perchlorate concentrations are elevated (>10 mg/L), making observation of reductions easier and (if successful) effecting a significant mass removal of perchlorate, while not being so high as to prevent effective treatment via the PRB;
- There is sufficient distance down-gradient of the test area prior to the Las Vegas Wash to monitor for degradation by-products, dissolution/release of compounds that may adversely affect water quality, and unconsumed substrate; and
- The area is not occupied by existing structures or in close proximity to drainage features/other factors which might influence surface or groundwater flow or access/transportation routes.

5.2 Preliminary Activities

To enable collection of site-specific groundwater and soil cuttings necessary to perform the bench-scale testing, soil borings and monitoring well installation will be performed. The newly installed monitoring wells are also planned for use in monitoring of the field-scale PRB during operation. Prior to installation of soil borings or groundwater monitoring wells, land access to the area for installation will need to be obtained from the City of Henderson. No less than 48 hours prior to the planned drilling activities, the Underground Service Alert (USA) will be notified to identify any possible subsurface utilities or piping that may be in the area of the planned installation. Following installation, the newly installed monitoring wells will be developed, purged and sampled. Both the groundwater sampled and the soil cuttings from within the aquifer from the well installation will be shipped to the laboratory for use in the bench-scale testing program (i.e., microcosm (serum bottle) testing and columns studies). These activities are discussed in further detail below.

5.2.1 Soil Boring and Well Installation

Eight monitoring wells will be drilled in accordance with Nevada Division of Water Resources (NDWR) requirements outlined in Nevada Administrative Code (NAC) Chapter 534, and notices of intent to drill will be submitted to the DWR for each of the eight new wells.

Three soil borings will be installed using a Mini Sonic drilling rig up-gradient from the candidate PRB pilot area. Soil cores will be described in the field by an experienced field geologist. Soil borings will be advanced through the alluvium and will be terminated at the contact of the alluvium and UMCf. Samples of groundwater and soil from the soil borings will be collected from each boring for use in bench-scale testing. Bench-scale testing is described in Section 5.3, below. The sample will be collected from the zone of saturation at each boring location.

Upon reaching the target depth at the top of the UMCf, the three soil borings will be converted to permanent monitoring wells. The monitoring wells will be constructed using 25-foot long, 2-inch diameter slotted polyvinyl chloride (PVC) screen and 2-inch diameter schedule 40 PVC riser to the ground surface. A filter pack of washed sand will be placed around the well screen to approximately 2 to 3 ft above the top of the screen. A seal consisting of approximately 2 to 3 ft of hydrated bentonite chips will be placed above the filter pack followed by bentonite/cement grout to the surface.

Following installation, the monitoring wells will be developed using a submersible pump. Well development will consist of removal of approximately 10 well volumes of groundwater from the monitoring wells. Standard Operating Procedures (SOPs) for photoionization detector (PID) screening for environmental sampling, soil sampling, and monitoring well installation and development are provided in Appendix B.

5.2.2 Groundwater Sampling and Analysis

Prior to groundwater sampling, water level measurements will be collected prior to the purging and sampling of the monitoring wells. The depth-to-water and the total well depth will be measured using an electronic water level meter. The water levels will be determined to the nearest 0.01 of a foot with an accuracy of ± 0.02 ft and the total well depth will be determined to the nearest 0.1 of a foot with an accuracy of ± 0.2 ft.

Monitoring wells will be purged and sampled using submersible pumps. Well purging will be conducted at a flow rate of approximately 0.5 liters per minute (lpm) to produce minimum drawdown within the well (i.e., less than 0.5 ft). After the first five to ten minutes of purging, a pumping depth to groundwater measurement will be collected to determine drawdown. If excessive drawdown is occurring, the purging rate will be reduced (i.e., 0.25 lpm).

In-line water quality parameters will be monitored during purging using a Horiba U-52 water quality meter, or equivalent, with a flow-through cell. Temperature, pH, conductivity, oxidation-reduction potential (ORP), turbidity, and dissolved oxygen (DO) measurements will be collected approximately every five minutes and recorded in a field notebook and/or groundwater sampling log forms along with the pumping rate, depth to water, and other observations. Purging will continue until pH, conductivity and turbidity readings have stabilized over three consecutive readings. The in-line water quality meter will be disconnected prior to sampling. At each well location, the groundwater samples will be obtained following the sampling SOPs of Appendix B and analyzed for the baseline parameters listed in Table 6.

Additionally and over the course of the performance of the column testing (described in Section 5.3.2 below), groundwater will be collected from well PC-98R, and collected in drums for shipment to the laboratory. Well PC-98R was chosen based on its vicinity to the candidate PRB location and the yield of this well observed during pump testing (Errol L. Montgomery & Associates, 2000).

5.2.3 Management of Investigation-Derived Wastes

In obtaining soil and groundwater for the bench scale tests, investigation-derived wastes including leftover soil cuttings (from drilling of boreholes), groundwater (from purging/development of monitoring wells), and spent personal protective equipment (PPE) will be generated.

Consistent with current management practices and pending waste characterization, waste soil and spent PPE will be stored in 55-gallon drums staged in a temporary holding area on the NERT Site located away from surface water features and storm drains. The drums will be labeled with a drum identification number, the description of the contents, the date generated, and the point of contact to be reached regarding questions. Based on the results of waste characterization samples, arrangements will be made for disposal.

Purged groundwater will be temporarily stored in suitable containers prior to being transferred to the on-site GWETS where it will undergo treatment before discharge to the Las Vegas Wash.

5.3 Bench Scale Testing

Bench-scale testing will provide information to enable selection of electron donors (EDs) and dosing rates and to identify the geometry and sizing of the PRB for field-scale pilot testing. The rationale for performing bench-scale testing, how information gained from bench-scale testing will be used to implement the field-scale pilot, and the schedule for performing testing is presented below.

The specific objectives of the proposed bench-scale treatability study are:

1. Identification of suitable EDs for perchlorate reduction.
2. Establish kinetic and hydraulic parameters required to design a field-scale PRB pilot.

The bench scale testing will be performed in two stages at an off-site laboratory. First, a microcosm study will be performed using jar tests that will enable the assessment of a wide variety of potential EDs. Based on the results of the microcosm studies, candidate ED would be selected for column studies. Flow-through column studies will be conducted using site-specific aquifer materials and water from the Site to mimic the conditions present at the candidate PRB location. A description of the bench-scale testing activities is provided in the sections that follow. Laboratory protocols for bench scale testing are provided in Appendix C.

5.3.1 Microcosm (Serum Bottle) Testing

Up to five, soluble, slow-release and solid EDs at two different doses will be tested in serum bottles to establish candidate amendments for perchlorate reduction. The serum bottles will be prepared using the site-specific soils and groundwater obtained during the initial well installation and the preliminary field activities at the candidate field-scale PRB location (described in Section 5.1 above), and spiked with an electron donor. The following is a list of EDs identified for testing:

1. Soluble EDs:
 - a. Lactate
 - b. Acetate
2. Proprietary slow-release electron donor:
 - a. Regenes HRC® or FMC EHC® or Duramend®)
3. Solid carbon EDs:
 - a. Compost and peat
 - b. Mulch mixed with sand or pea gravel

The above EDs were selected based on their ability to be applied to a variety of potential PRB morphologies (e.g., via direct injection, passive diffusion wells or within a trenched wall), their demonstrated success in similar environments based on review of case studies and published research, and cost-effectiveness in full-scale application. Acetate was selected as it can be readily metabolized by a variety of microflora and requires relatively low energy to be utilized. Lactate ferments directly to acetate, and has been used in PRBs such as the case study at the Naval Surface Warfare Center in Indian Head, Maryland, summarized in Table 5. Proprietary EDs, Regenes HRC®, FMC EHC® and Duramend®, have been identified for testing as these products provide the advantage of slow release to extend the longevity of the PRB between dosings along with the associated efficiencies of application. Each of these proprietary products has been specifically formulated for use in in-situ anaerobic degradation of halogenated organic compounds, and would be effective at reducing perchlorate. Following approval of this Work Plan, a vendor will be selected to supply one of these proprietary EDs for testing. The solid carbon EDs, hard wood mulch, peat, and compost, have been chosen based on their common availability and extended release properties. Each of these solid substrates has advantages and disadvantages. For example, the lignins in mulch are not readily available for

biodegradation as a carbon source, and thereby mulch can be less efficient as a substrate compared to peat. Compost and peat may be less commercially available than mulch and therefore can be more expensive. The addition of gravel or sand and peat to these substrates will provide the necessary structure to achieve the desired hydraulic characteristics for flow of groundwater through the PRB. As summarized in Table 5, the use of mulch, compost and peat as EDs in PRBs has been demonstrated at sites such as the Naval Weapons Industrial Reserve Plant in McGregor, Texas and Whiteman Air Force Base near Kansas City, Missouri.

Based on the results of the microcosm testing, selection of the amendments for follow-on testing in columns constructed with soil cuttings from the aquifer matrix will be made. To establish effectiveness, serum bottle testing will be conducted on mixtures of Site aquifer material, Site groundwater, and two different concentrations of the candidate donors. Materials will be assembled in a glove box in 160 milliliter serum bottles sealed with Teflon-lined septa and crimp caps (Tan et al., 2004 and Jackson et al., 2004). A summary of sampling parameters and frequency is provided below.

Microcosm (serum bottle) Testing - Summary of Testing Parameters and Frequency

| Parameter (Analytical Method) ^{1,2} | Frequency |
|---|--|
| Perchlorate by IC-MS/MS ¹ Nitrate/nitrate (USEPA Method 300.0), Conductivity (microelectrode) | Weekly for 8 weeks |
| Redox indicators plus Chloride Dissolved oxygen (microelectrode), Chloride, sulfate, (USEPA Method 300.0), Sulfide (HACH Method 8131 (USEPA Methylene Blue Method)), Ferric and ferrous iron (HACH Method 8008 and 8147), Methane in headspace (GC-FID (Kampbell and Vandegrift, 1998) ²). | Bi-weekly (due to limited volume of water in serum bottle) |
| Dissolved Metals (Ag, As, B, Ba, Be, Ca, Cd, Cr, Co, Cu, Fe, Hg, K, Mo, Mg, Mn, Na, Ni, Pb, Sb, Se, Ti, Zn, and U) (USEPA Methods 6010/6020/7400/200.8) | At termination of the study |
| QA/QC | Duplicates will be run on 5% of the samples. Typical runs will consist of blanks, daily calibration check samples, and runs of standard reference materials, when available. |

¹ [ClO4- concentrations will be measured by sequential ion chromatography-mass spectroscopy-mass spectroscopy \(IC-MS/MS\). ClO4- will be quantified using a Dionex LC 20 ion chromatography system consisting of GP50 pump, CD25 conductivity detector, AS40 automated sampler and Dionex IonPac AS16 \(250 X 2 mm\) analytical column. A hydroxide \(NaOH\) eluent at 0.3 milliliters per minute \(mL min-1\) is followed by 90% acetonitrile \(0.3 mL min-1\) as a post-column solvent. To overcome matrix effects, all samples are spiked with Cl18O3 or Cl18O4 internal standards.](#)

² [Kampbell, D.H. and S.A. Vandegrift. 1998. Analysis of Dissolved Methane, Ethane, and Ethylene in Ground Water by a Standard Gas Chromatographic Technique. J. of Chromatographic Sci. 36:253-256.](#)

Bottles will be repetitively sampled over time to establish the kinetics of perchlorate reduction. In addition to perchlorate, concentrations of redox pairs will be measured as the changes in the aquifer material/groundwater systems progress. These will include oxygen, nitrate/nitrite, ferric/ferrous iron, sulfate/sulfide and methane. The microcosm studies will be run for a period of approximately 6 to 8 weeks or until target perchlorate reductions in the serum bottles are achieved. EDs that are successful at perchlorate reduction in the serum bottles will be selected for further evaluation in column testing.

5.3.2 Column Testing

Column studies will be performed on the EDs selected from the results of the microcosm study. The column study will be used to test the effectiveness of donors in a flow-through mode simulating field conditions of the Site. Successful donors will be those that reduce perchlorate but also maintain the hydraulic properties of the formation (minimize biofouling). A schematic diagram of the 1-D column system is shown in the laboratory column setup illustration below.

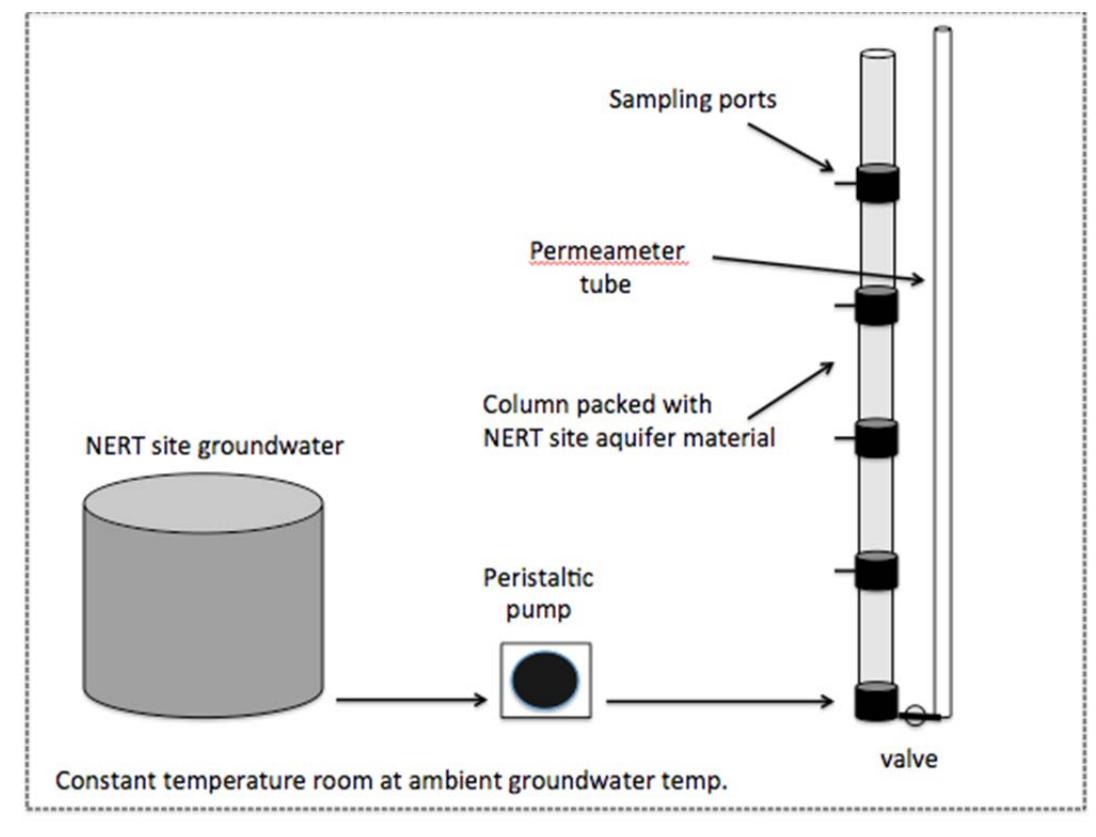

Column experiments will be performed in three, 5-foot long, 2-inch diameter columns with five equally spaced sampling ports located along their lengths. The columns will be packed with aquifer matrix material from the candidate PRB location at the NERT Site. A 5-centimeter layer of fine gravel will be placed at the bottom to equalize the distribution of flow through the column. Glass wool will be inserted in the inner side of sampling ports to avoid dead zones and clogging of sampling ports. Immediately after establishment of the columns, the hydraulic conductivity of

the test columns will be assessed by connecting a falling head permeameter to the column. Hydraulic conductivity will be measured using the falling head method and compared to existing data for the Site.

Laboratory Column Set-up

Groundwater collected from the candidate PRB location at the Site will be shipped to the off-site laboratory and introduced through 2 millimeter stainless steel tubing in up-flow mode. A peristaltic pump with Viton tubing will be used to convey water through the column at groundwater velocities representative of conditions at the candidate location for the field-scale PRB. The experiment will be set-up in a constant temperature room so that groundwater and the test columns will be maintained at the same ambient temperature as present at the candidate PRB location.

The influent concentrations will be monitored three times a week to track changes in perchlorate concentration. Influent samples for all column experiments will be collected at the sampling ports on the delivery side of the pump. Samples from each sample port will be collected with a 5 mL pre-rinsed airtight glass syringe fitted with luer-lock and injected into 2 mL glass vials. Sampling will be performed after every three to four days for determination of perchlorate concentration, nitrate/nitrite concentrations and conductivity. On a weekly basis, additional redox indicators will be measured including dissolved oxygen, nitrite, nitrate, ferrous iron, ferric iron, sulfate and sulfide, and methane. Oxidation-reduction characteristics of each sampled zone will be determined from the water chemistry parameter results. Additional samples will be collected from the columns for metals analysis at an external certified laboratory. Column studies will be run for a period of approximately 12 weeks, subject to extension if additional information is desired. Following the termination of the studies, the falling head permeameter study will be repeated and the hydraulic conductivity measured again to assess the effect on aquifer hydraulic properties. Declines in conductivity over the 12 weeks will provide an evidence of conditions that may be conducive to biofouling. If conductivity declines significantly (e.g., greater than 5 to 10 times the initially measured hydraulic conductivity), column materials will be removed and total carbon measured on the aquifer material to determine the amount of biomass accumulated along the flow path.

Analytical Procedures

Major anions (Cl^- , NO_3^- , and SO_4^{2-}) will be analyzed by ion chromatography following U.S. Environmental Protection Agency (USEPA) Method 300.0. Perchlorate concentrations will be separately measured by sequential ion chromatography-mass spectroscopy-mass spectroscopy (IC-MS/MS). Redox parameters will be measured using standard methods for DO (by microelectrode), nitrite, nitrate, ferrous and ferric iron, sulfate, sulfide (by ion chromatograph), and methane in pore water (by GC-FID). To assess the liberation of metals from the aquifer matrix, samples will also be collected for metals analysis over the course of the column testing. Below is a summary of the testing parameters, analytical methods and frequency for the column testing.

Column Testing - Summary of Testing Parameters and Frequency

| Location | Parameter (Analytical Method) | Frequency |
|------------------|---|---|
| Column influent | Perchlorate by IC-MS/MS ³ | 3 times/week for 12 weeks |
| Sample ports | Perchlorate by IC-MS/MS ¹ , Nitrate/nitrite (USEPA Method 300.0), Conductivity (microelectrode) | Every 3 to 4 days |
| All Sample Ports | Redox indicators plus Chloride <ul style="list-style-type: none"> • Dissolved oxygen (microelectrode), • Chloride, nitrite, nitrate, ferrous and ferric iron, sulfate, sulfide (USEPA Method 300.0), • Sulfide (HACH Method 8131 (USEPA Methylene Blue Method)) • Ferric and ferrous iron (HACH Method 8008 and 8147) • Methane in pore water (GC-FID⁴) | Weekly |
| Column Effluent | Dissolved Metals (Ag, As, B, Ba, Be, Ca, Cd, Cr, Co, Cu, Fe, Hg, K, Mo, Mg, Mn, Na, Ni, Pb, Sb, Se, Ti, Zn, and U) (USEPA Methods 6010/6020/7400/200.8) | Every two weeks |
| Each Column | Hydraulic conductivity (Falling Head Permeability Test (ASTM D5084-10)) | At beginning and after termination of study |

QA/QC

Duplicates will be run on 5% of the samples. Typical runs will consist of blanks, daily calibration check samples, and runs of standard reference materials, when available. Split samples can be provided for analysis upon request.

5.3.3 Establishment of Parameters for Field-Scale Design

Column data for removal of perchlorate will be assessed using 1-D reactive-transport models. To assess the kinetics of perchlorate degradation, concentrations of perchlorate will be measured along the length of the columns over time. Flow of groundwater from the candidate PRB location at the Site will be added at a controlled rate so as to maintain a constant velocity. The temperature of the laboratory where the columns will be located will be maintained at the same temperature as the aquifer at the Site.

³ ClO₄⁻ concentrations will be measured by sequential ion chromatography-mass spectroscopy-mass spectroscopy (IC-MS/MS). ClO₄⁻ will be quantified using a Dionex LC 20 ion chromatography system consisting of GP50 pump, CD25 conductivity detector, AS40 automated sampler and Dionex IonPac AS16 (250 X 2 mm) analytical column. A hydroxide (NaOH) eluent at 0.3 milliliters per minute (mL min⁻¹) is followed by 90% acetonitrile (0.3 mL min⁻¹) as a post-column solvent. To overcome matrix effects, all samples are spiked with Cl¹⁸O₃ or Cl¹⁸O₄ internal standards.

⁴ Kampell, D.H. and S.A. Vandegrift. 1998. Analysis of Dissolved Methane, Ethane, and Ethylene in Ground Water by a Standard Gas Chromatographic Technique. J. of Chromatographic Sci. 36:253-256.

5.3.4 Reporting

At the conclusion of the column studies and completion of the bench-scale testing activities, a report of the bench-scale testing will be prepared and submitted to the NDEP.

5.3.5 Final Design and Permitting

Utilizing the results of the bench-scale testing, a Design Report for the Final Field-Scale PRB Pilot will be prepared and submitted to the NDEP. The Design Report will include the detailed plans and specifications for the field-scale construction, along with operation and monitoring plans.

Installation of the PRB will require obtaining a General Permit as a Class V Underground Injection Control (UIC) well, if an injectable amendment is selected. Class V UIC wells are non-hazardous wells that inject fluids above the underground source of drinking water (USDW). The injected PRB qualifies for a general permit under the Nevada regulation NAC 445A.891. This regulation states that Class V “[w]ells used to inject remediation enhancement products at remediation sites” are eligible for a general permit.

Following NDEP approval of this Treatability Study Work Plan, an application for a UIC General Permit for Short-Term Remediation will be filed. UIC General Permits for Short-Term Remediation only allow for a one-time injection of electron donor amendments, and are valid for a period of less than six months. As it is anticipated that the field-scale PRB may operate for a period in excess of six months, application for a UIC General Permit for Long-Term Remediation may be necessary at that time.

The permitting process for either Long-Term or Short-Term Remediation Permits requires the submission of the project work plan, a letter of concurrence, UIC Form 200, Notice of Intent (NOI) Form U210, and the respective fees for each permit. General UIC permits are typically issued within 60 days of submission.

Additional permits may be required for construction and will be identified as part of the final design for the PRB field-scale pilot.

6 Monitoring

6.1 Preliminary Groundwater Monitoring Plan

Groundwater sampling frequency during the pilot test will be established based on the reaction rates observed in the bench scale tests. From the case study review, a potential sampling frequency could be every two weeks for the first sixty days, with the frequency decreasing to a monthly sampling rate after the sixty day mark. This sampling frequency was utilized at the Aerojet General Corporation's site in Rancho Cordova, California and was effective in evaluation of perchlorate removal efficiencies in this application. A monthly sampling frequency, as done in the Charleston Naval Weapons Station PRB installation, has shown to provide sufficient data to demonstrate efficacy of the PRB treatment.

A suite of groundwater sampling parameters envisioned for monitoring the performance of the field-scale PRB pilot is included in Table 6. Baseline sampling would be performed for all of the newly installed monitoring wells, existing monitoring wells and piezometers identified in Section 6.2 below prior to the installation of the field-scale PRB, and would be sampled monthly thereafter during operation of the PRB. Based on the results observed certain parameters could be reduced in frequency or dropped from the monitoring program, as appropriate. Performance monitoring would be performed based on observed results and Site conditions, but is anticipated to be performed after the installation and commencement of operation of the PRB and monthly thereafter during PRB operations.

6.2 Monitoring Well Locations

A conceptual layout of the monitoring wells and piezometers for the field-scale PRB installation is illustrated in Figure 6. A staggered well layout was selected to provide for monitoring of the groundwater conditions both laterally and downgradient of the field-scale PRB. The illustrated spacing of the monitoring wells was based on an assumed hydraulic conductivity of approximately 35 ft/day and the results of the Northgate bench-scale study that indicated successful perchlorate reductions within 14 days. Existing wells (PC-98R and MW-K5) will also be used to provide information on upgradient groundwater quality and elevations. A monitoring well located within the PRB itself is included to provide information on the geochemistry within the barrier and to provide a means to observe signs of potential biofouling. Piezometers are included to monitor for changes in groundwater elevations as impacts to groundwater flow, or reductions in hydraulic conductivity that could signal biofouling of the PRB.

7 Schedule

A preliminary schedule for implementing the activities presented in this Work Plan is provided in Figure 7. The duration of the microcosm and columns studies is based on experience and the time necessary for acclimation of the microflora and for adjustments in dosing rates. Based on the results of the bench-scale testing, the design for the field-scale pilot would be finalized, along with a schedule for installation and associated plans (e.g., final operations and monitoring plans). A preliminary schedule for construction and operation of the field-scale pilot is included in the time schedule of Figure 7, however, the time frame presented may need to be adjusted based on the field-scale pilot design.

8 References

- CH2MHill. 2010. The Evolution of a Field Application of nano Scale Zero Valent Iron (nZVI) in a Deep Low Permeability Aquifer. February.
- ENVIRON. 2011a. Phase I Environmental Site Assessment of Tronox LLC, Clark County, Nevada. January.
- ENVIRON. 2011b. Annual Remedial Performance Report for Chromium and Perchlorate, NERT Site, Henderson, Nevada July 2010 – June 2011. August 26.
- ENVIRON. 2012. Semi-Annual Remedial Performance Report for Chromium and Perchlorate, NERT Site, Henderson, Nevada, July 2011 – June 2012 December 2011. August 31 February 29.
- Errol L. Montgomery & Associates Inc. 2000. Analysis of Rate of Groundwater Movement Based on Results of Tracer and Hydraulic Tests Conducted Between Pittman Lateral and Seep Area Henderson, Nevada. December 19.
- ESTCP (U.S. Department of Defense, Environmental Security Technology Certification Program). 2010. Cost and Performance Report (ER-0221), Edible Oil Barriers for Treatment of Chlorinated Solvent and Perchlorate-Contaminated Groundwater. February.
- FRTR (Federal Remediation Technologies Roundtable). 2005. Federal Remediation Technologies Reference Guide and Screening Manual, Version 4.0. February 1. Available at: http://www.frtr.gov/matrix2/top_page.html
- ITRC (Interstate Technology & Regulatory Council). 2008. Remediation Technologies for Perchlorate Contamination in Water and Soil. PERC-2. Washington, D.C.: Interstate Technology & Regulatory Council, Perchlorate Team. March. Available at: www.itrcweb.org
- Jackson, W. Andrew, M. Jeon, J. H. Pardue, and T. Anderson. 2004. Enhanced Natural Attenuation of Perchlorate in Soils Using Electrokinetic Injection. Bioremediation Journal. 8(1-2):65-79.
- Kampell, D.H. and S.A. Vandegrift. 1998. Analysis of Dissolved Methane, Ethane, and Ethylene in Ground Water by a Standard Gas Chromatographic Technique. J. of Chromatographic Sci. 36:253-256.
- Kerr-McGee Chemical LLC. 2001. Seep Area Groundwater Characterization Report, Henderson Nevada Facility January 18.
- NDEP (Nevada Division of Environmental Protection). 2010. Letter to Tronox LLC, Response to Shaw's proposal for demonstration of perchlorate treatment within groundwater using an injected PRB. April 15.

- Northgate (Northgate Environmental Management, Inc.). 2010. Work Plan to Conduct In-Situ Permeable Reactive Barrier Pilot Test for Perchlorate-Impacted Groundwater, Tronox LLC, Henderson, Nevada October 25.
- Northgate. 2011. Bench-Scale Experiments in Support of an In Situ Permeable Reactive Barrier Pilot Test: Effective Oil Retention, Biological Reduction of Perchlorate, and Metals Mobilization Using Site-Specific Soils and Groundwater, Nevada Environmental Response Trust Site, Henderson, Nevada. March 28.
- SERDP (U.S. Department of Defense Strategic Environmental Research & Development Program). 2009. "In-Situ Bioremediation of Perchlorate in Groundwater". Springer Science+Business Media, LLC.
- Shaw (Shaw Environmental Inc.). 2010. Proposal for Demonstration of Perchlorate Treatment within Groundwater Using an Injected Permeable Reactive Barrier. February 14.
- Shaw Environmental. 2009. Final Report, In Situ Bioremediation of Perchlorate in Groundwater, ESTCP Project ER-0224. July.
- Solutions-IES, Inc. 2008. Final Report, Edible Oil Barriers for Treatment of Chlorinated Solvent and Perchlorate-Contaminated Groundwater, ESTCP Project ER-0221. February.
- Solutions-IES, Inc. 2010. Final Report, Evaluation of Potential for Monitored Natural Attenuation of Perchlorate in Groundwater (Indian Head), ESTCP Project ER-200428. July.
- Tan, K., T.A. Anderson and W.A. Jackson. 2004. Degradation Kinetics of Perchlorate in Sediments and Soils. *Water, Air, and Soil Pollution*. 151:245-259.
- USEPA (U.S. Environmental Protection Agency). 2006. Contaminated Site Clean-up Information, Technology News and Trends Newsletter, November 2006 Issue. (<http://clu.in.org/products/newsletters/tnandt/view.cfm?issue=1106.cfm> last accessed August 25, 2012). November.

Figures



Legend

- ▬ Approximate Site Boundary
- ▬ Assessor Parcel Boundaries

Source of parcel info: Clark County Tax Assessor
 (<http://www.clarkcountynv.gov/depts/assessor/pages/default.aspx>); last accessed 11/29/2012

Image courtesy of USGS Image courtesy of the Nevada State Mapping Advisory Committee © 2012
 Microsoft Corporation

Path: H:\LePétomane\NERT\Soil_Excavation\GIS\Maps\Other Figures\Figure2_SiteFeatures_working.mxd

Site Location Map and Candidate PRB Test Location
 Nevada Environmental Response Trust Site, Henderson, Nevada

Figure
1

Drafter: EA Date: 12/7/2012 Contract Number: 21-29100H Approved by: BSK Revised:



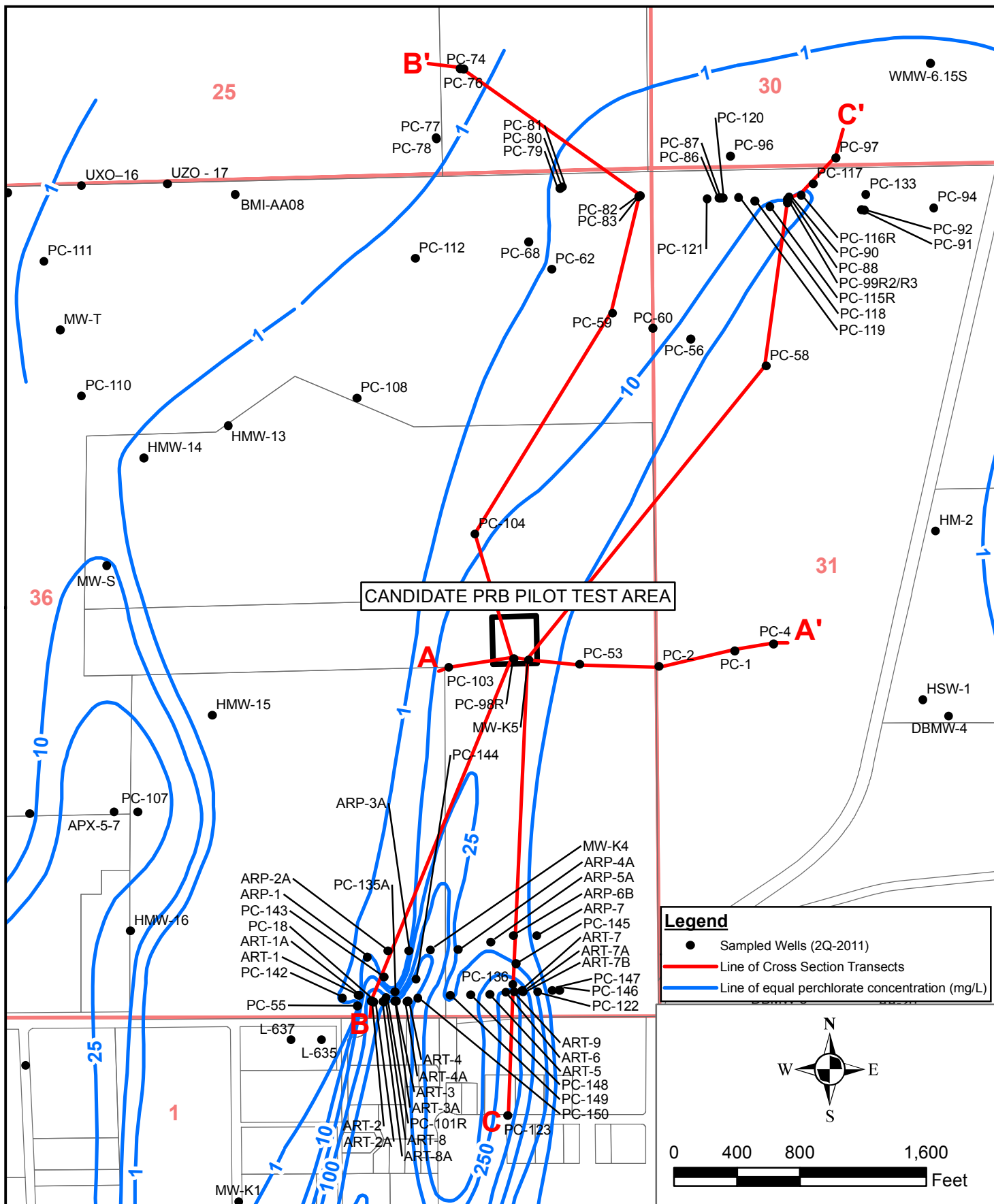

L:\Loop Project Files\00_CAD FILES\21\Lept XXVII\NERT Remediation 21-29100H\GIS\MXDs\PRB_Work_Plan\Figure2_PRB_PlotiesArea.mxd



PROPOSED PRB PILOT TEST LOCATION

Nevada Environmental Response Trust Site, Henderson, Nevada

Figure

2

Drafter: CCS

Date: 11/29/2012

Contract Number: 21-29100H

Approved by: BSK

Revised:

CROSS-SECTION LOCATIONS

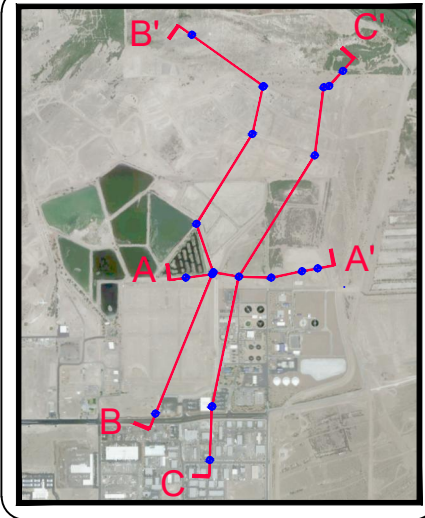

Notes:

1. Perchlorate concentration in mg/L.
2. Groundwater levels and perchlorate concentrations for PC-1, PC-2, and PC-4 were collected on May 3, 2011.
3. Groundwater levels and perchlorate concentrations for PC-103, PC-98R, MW-K5, and PC-53 were collected on December 13, 2011.
4. PC-1 was dry and no sample was collected.
5. Groundwater level perchlorate concentration not available for PC-100R.
6. Groundwater levels and perchlorate concentrations are from Appendix A in the *Semi-Annual Remedial Performance Report for Chromium & Perchlorate*, February 2012.
7. Lithology and well construction details from site boring logs and are included in Appendix A.

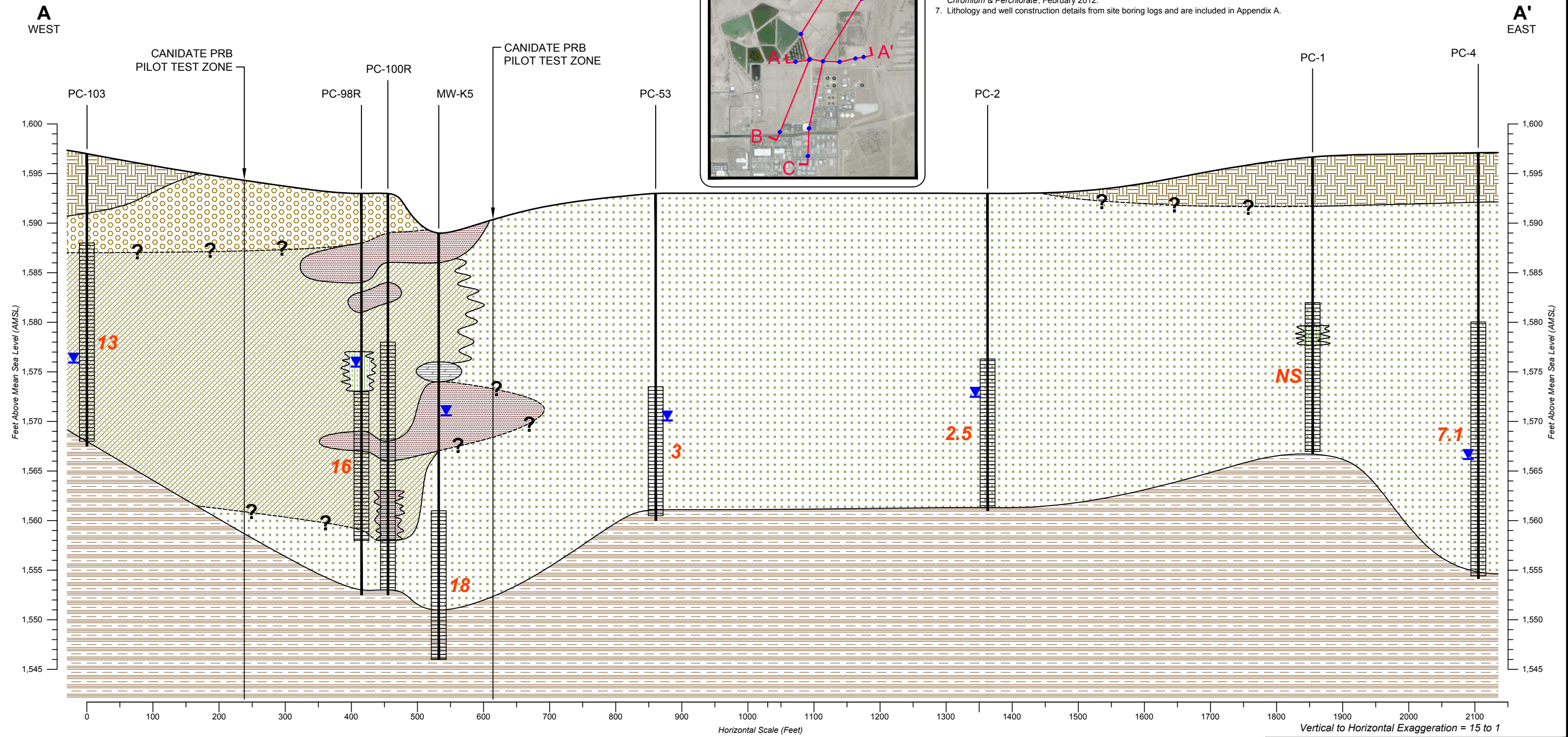

LEGEND

| | | | | | | | | | | | | | | | | | |
|--|---------------------------|--|------|--|---------------|--|------|--|---------------------|--|-----------------------|--|------------|--|---------|--|------------|
| | MONITORING WELL | | FILL | | GRAVELLY SAND | | SAND | | SILTY SAND / GRAVEL | | GRAVEL / SANDY GRAVEL | | SANDY CLAY | | CALICHE | | SILTY CLAY |
| | WATER LEVEL | | | | | | | | | | | | | | | | |
| | WELL SCREEN | | | | | | | | | | | | | | | | |
| | PERCHLORATE SAMPLE (mg/L) | | | | | | | | | | | | | | | | |

CROSS-SECTION A - A'
NEVADA ENVIRONMENTAL
RESPONSE TRUST
HENDERSON, NEVADA



FIGURE
3

DRAFTED BY: ELS

DATE: 12/17/12

21-9100H

L:\Loop Project Files\00_CAD FILES\21\Leper XXVII NERT Remediation 21-29100H\Completion of Tech Screen\03_Cross-Section A-A'.dwg

L:\Loop Project Files\00_CAD FILES\21\Leper XXVII NERT Remediation 21-29100H\Completion of Tech Screen\04_Cross-Section B-B'.dwg

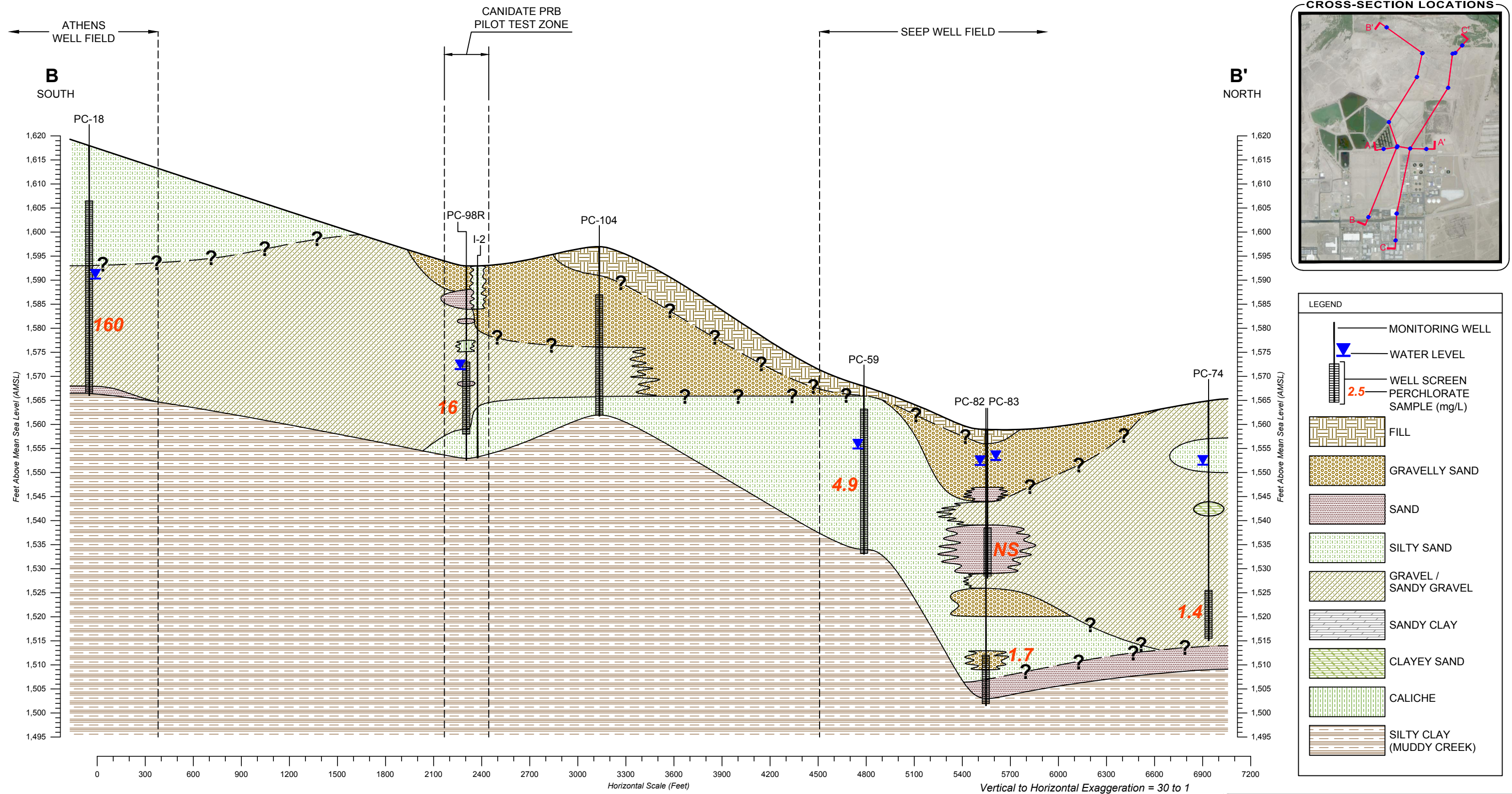

Notes:

1. Perchloration concentration in mg/L.
2. Groundwater levels and perchloration concentrations for PC-74, PC-82, and PC-83 were collected on May 2-3, 2011.
3. Groundwater levels and perchloration concentrations for PC-18, PC-59, and PC-98R were collected on December 12-13, 2011.
4. No sample was collected at PC-83.
5. Groundwater level perchloration concentration not available for PC-104.
6. Groundwater levels and perchloration concentrations are from Appendix A in the *Semi-Annual Remedial Performance Report for Chromium & Perchloration*, February 2012.
7. Lithology and well construction details from site boring logs and are included in Appendix A.

CROSS-SECTION B - B'
 NEVADA ENVIRONMENTAL
 RESPONSE TRUST
 HENDERSON, NEVADA



FIGURE
4

DRAFTED BY: ELS

DATE: 12/17/12

21-9100H

L:\Loop Project Files\00_CAD FILES\21\Leper XXVII NERT Remediation 21-29100H\Completion of Tech Screen\05_Cross-Section C-C'.dwg

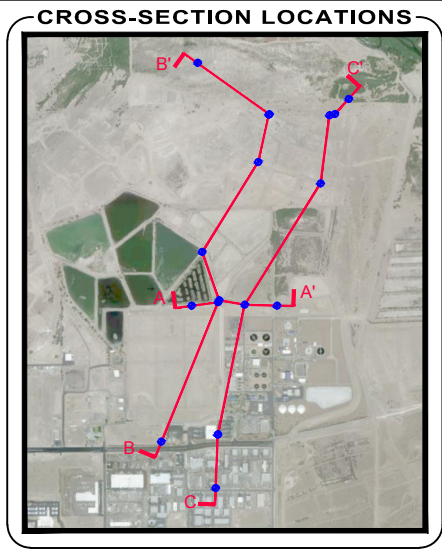
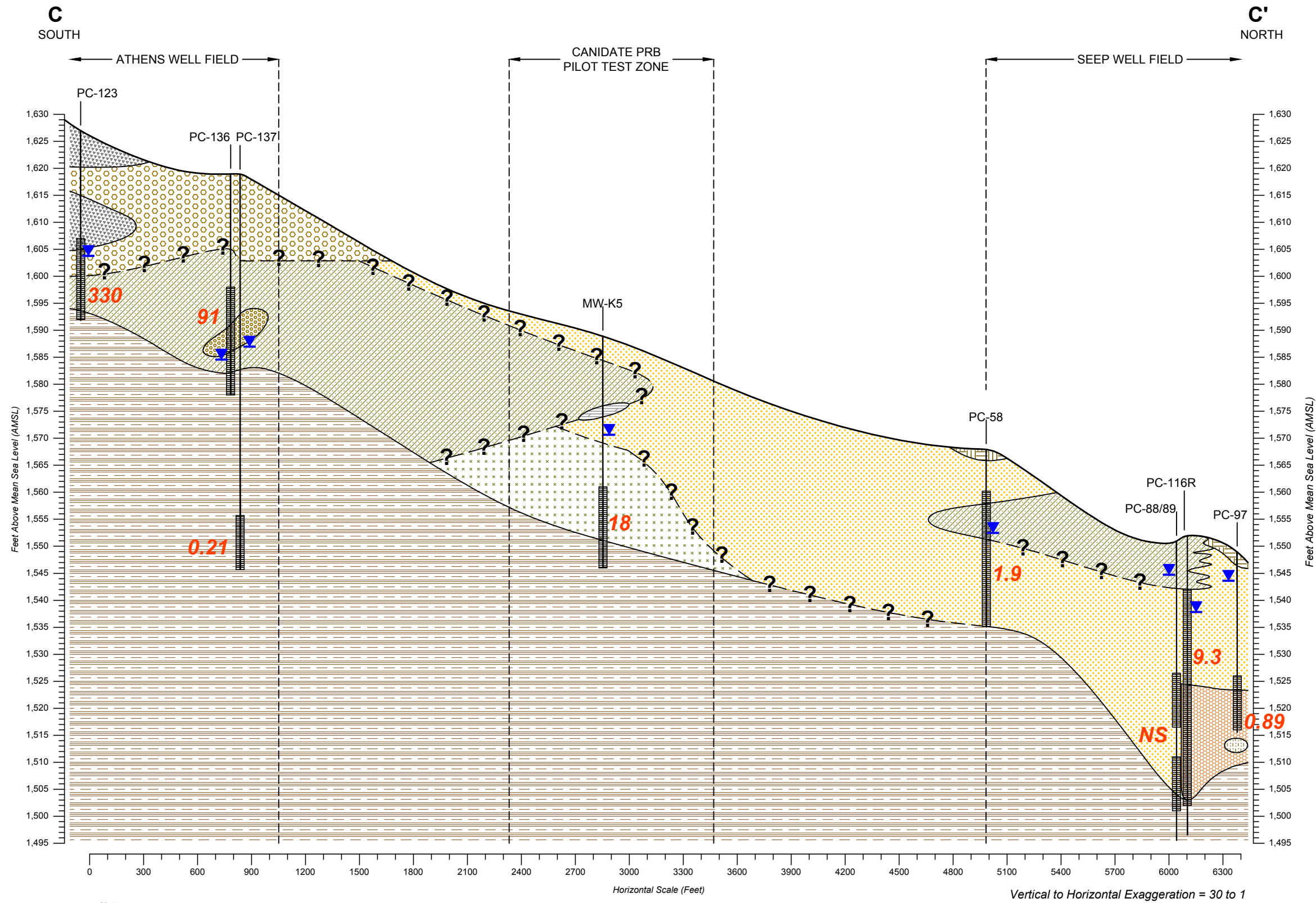

LEGEND

| | |
|--|---------------------------|
| | MONITORING WELL |
| | WATER LEVEL |
| | WELL SCREEN |
| | PERCHLORATE SAMPLE (mg/L) |
| | FILL |
| | GRAVELLY / SAND |
| | GRAVEL |
| | GRAVEL / SANDY GRAVEL |
| | SILTY GRAVELLY SAND |
| | SANDY SILTY GRAVEL |
| | SANDY CLAY |
| | SILTY SAND |
| | SILTY SAND / GRAVEL |
| | SILTY CLAY (MUDDY CREEK) |

- Notes:**
1. Perchlorate concentration in mg/L.
 2. Groundwater levels and perchlorate concentrations for PC-88 were collected on May 2, 2011.
 3. Groundwater levels and perchlorate concentrations for PC-123, PC-136, and PC-137 were collected October 31-November 1, 2011.
 4. Groundwater levels and perchlorate concentrations for MW-K5, PC-97, and PC-116R were collected December 5-31, 2011.
 5. No sample was collected at PC-88.
 6. Groundwater levels and perchlorate concentration not available for PC-89.
 7. Groundwater level perchlorate concentrations are from Appendix A in the *Semi-Annual Remedial Performance Report for Chromium & Perchlorate*, February 2012.
 8. Lithology and well construction details from site boring logs are included in Appendix A.

CROSS-SECTION C - C'
NEVADA ENVIRONMENTAL
RESPONSE TRUST
HENDERSON, NEVADA

| | |
|-----------------|----------------|
| | FIGURE |
| | 5 |
| DRAFTED BY: ELS | DATE: 12/17/12 |
| | 21-29100H |

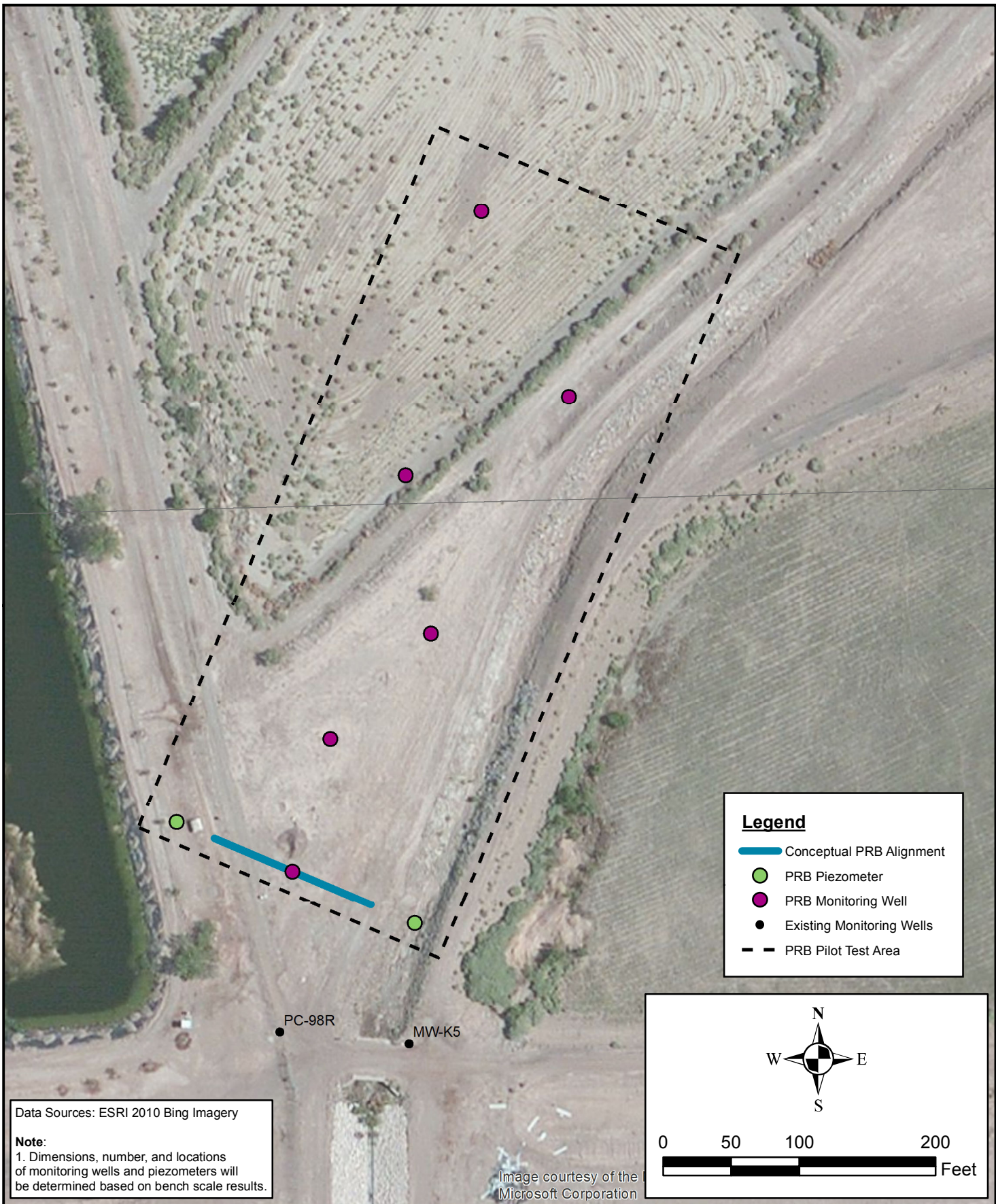

Data Sources: ESRI 2010 Bing Imagery

Note:
 1. Dimensions, number, and locations of monitoring wells and piezometers will be determined based on bench scale results.

Image courtesy of the Microsoft Corporation

Legend

- Conceptual PRB Alignment
- PRB Piezometer
- PRB Monitoring Well
- Existing Monitoring Wells
- PRB Pilot Test Area

0 50 100 200 Feet



CONCEPTUAL LAYOUT OF PILOT SCALE PRB
 Nevada Environmental Response Trust Site, Henderson, Nevada

Figure
6

L:\Loop Project Files\00_CAD FILES\21\Leperet XXVII NERT Remediation 21-29100H\GIS\MXDs\PRB_Work_Plan\Figure6_ConceptualLayout\PilotScalePRB_r3.mxd

Figure 7. Preliminary Time Schedule for PRB Treatability Study

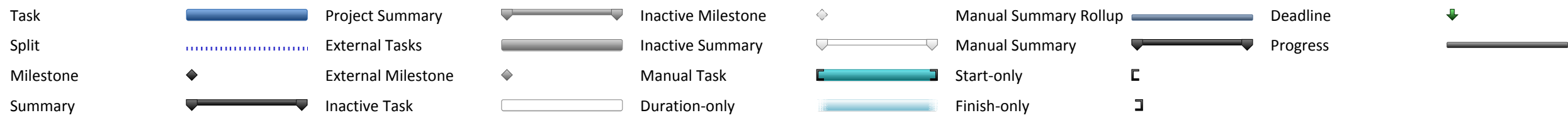
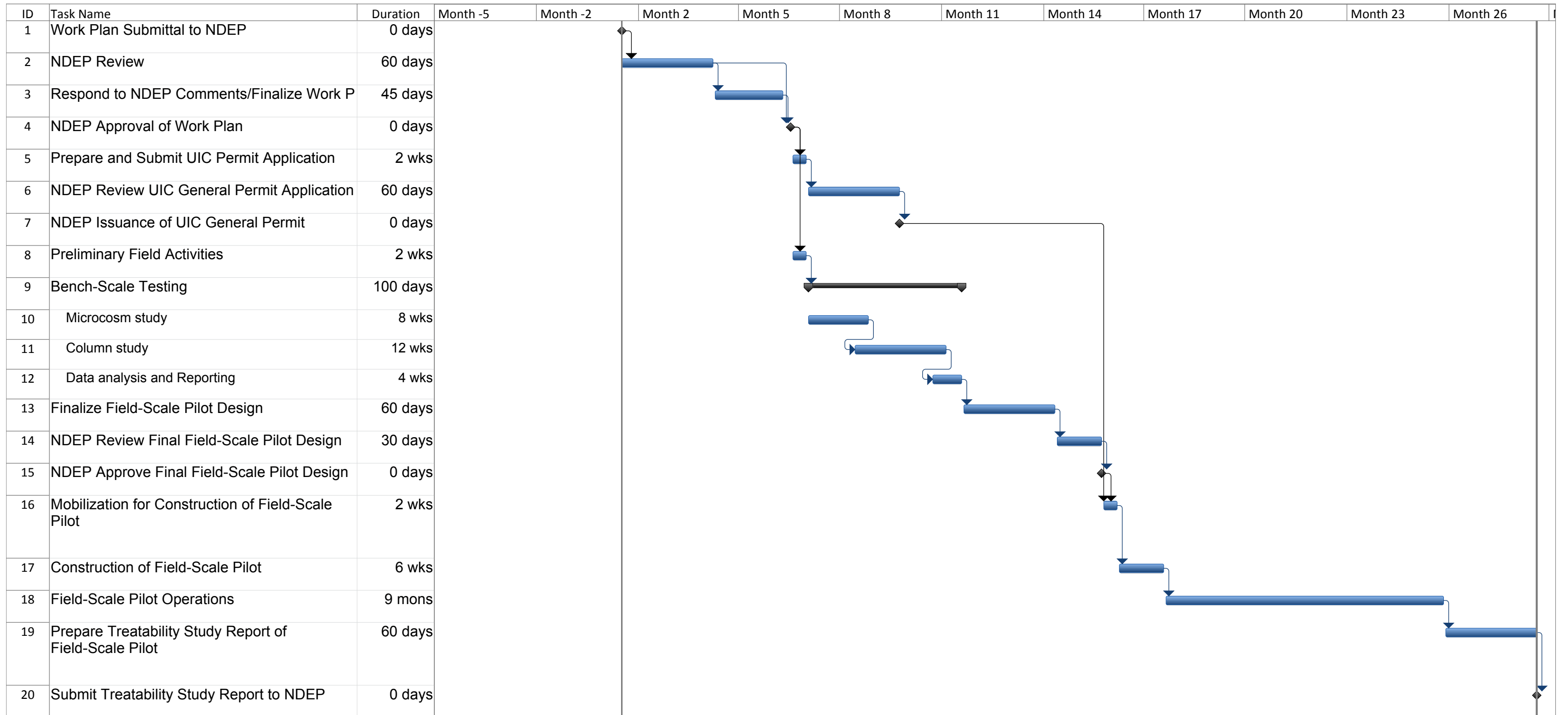

Tables

**TABLE 1
Summary of Work Performed by Others**

| Date of Study | Type of Study | Performed by | Details of Testing/Observations | Conclusions/Results |
|---------------|--|--|---|--|
| 12/19/2000 | Hydrogeologic | Errol L. Montgomery and Associates Inc. | In 2000, Errol L. Montgomery and Associates Inc. performed an assessment on the siteSite titled "Analysis of Rate of Groundwater Movement Based on Results of Tracer and Hydraulic Tests Conducted between Pittman Lateral and Seep Area, Henderson, Nevada (Errol L. Montgomery & Associates, 2000). This assessment was undertaken prior to establishment of the existing GWETS system, therefore the conclusions of the study may not be entirely representative of current hydrogeological conditions. The assessment was undertaken in order to determine the rate of groundwater flow across the Site area which in turn could be used to estimate the rate of perchlorate transport within groundwater across the Site. The assessment comprised three study areas one of which, Area B (near monitoring well MW-K5) being in the area of the proposed PRB field scale trial. . The assessment comprised tracer testing using bromide and deionized water and hydraulic tests. | The assessment determined the following with respect to Area B: <ul style="list-style-type: none"> • Rate of groundwater movement was in the range of 30 to 45 ft(ft)/day; and • Aquifer thickness was 25 ft, transmissivity was 55,000 gallons per day (gpd)/ft and hydraulic conductivity was 2,200 gpd/ft2. The report also noted that the lower parts of the aquifer (i.e.i.e., the alluvium) comprise coarser grained sediments which appear to facilitate more rapid groundwater movement. Specifically, the results of a pump test, performed at monitoring well PC-98R and within the candidate PRB pilot area, wereas reported. The pump test ran for 29.9 hours and the average pumping rate was circa 52 gallons per minute. The results of the pump test were: <ul style="list-style-type: none"> • Transmissivity was circa 60,000 gpd/ft; • Hydraulic conductivity was estimated at 2,400 gpd/ft2; and • Storativity was approximately 0.08 (Errol L. Montgomery & Associates, 2000). |
| 1/18/2001 | Seep Groundwater Characterization | Kerr-McGee Chemical, LLC | Work was undertaken to provide supplementary information in the design of the GWETS system. The specific objectives of the assessment were to: <ul style="list-style-type: none"> • Determine the hydrogeologic regime in the area between the Pittman lateral and the Seep; • Determine the representative perchlorate concentration in the saturated thickness of the alluvial aquifer near the Seep; • Determine if any additional pathways exist along the Las Vegas Wash for other significant perchlorate contribution; • Determine the rate of movement and the residence time for perchlorate and groundwater between the Pittman lateral and the Seep; and • Determine potential groundwater pumping strategies. | The results of the investigation indicated: <ul style="list-style-type: none"> • The BMI Lower Ponds area (encompassing the Seep) was the only identified groundwater discharge containing significant perchlorate concentrations entering the Las Vegas Wash; • In the Lower Ponds area, the main north/northeast trending alluvial paleochannel coalesces with a second poorly defined paleochannel entering the area from the southwest; • In the Lower Ponds area, where the two paleochannels coalesce, the entire saturated interval of the alluvial aquifer contained perchlorate >10 milligrams per liter (mg/L) over a width of approximately 2,200 feetft; • The COH-RIB facility contributed significant amounts of treated wastewater at random times for random periods of time and directly contributed to daylighting of groundwater in the Lower Ponds area and to wide fluctuations in both the flow volume and perchlorate content of the Seep; and • The rate of movement for groundwater and perchlorate between the Pittman Lateral and the Seep averaged 35 ft/day and the residence time was approximately six months. |
| 2/14/2010 | Work Plan for PRB Pilot Testing | Shaw Environmental, Inc. | A Work Plan was prepared to undertake a field-scale trial of a PRB comprising the injection of slow release, edible oil organic substrate (EOS®598) into the saturated alluvium overlying the Muddy Creek Formation. . The PRB would be formed using a series of fixed point injection locations installed to a depth of 40 ft bgs. | In an NDEP letter to Shaw dated April 15, 2010), the Department commented that other, pertinent assessments had been carried out in the proposed PRB area employing aquifer tests, natural gradient tracer tests and injected/pump-back tracer tests (Kerr-McGee, 2001 and Errol Montgomery and Associates, 2000) and that these should be considered in justifying the proposed location of the PRB. Shaw did not progress to actually undertaking the field scale trial. |
| 10/25/2010 | Emulsion Retention Testing and Bench-Scale Jar Testing | Northgate Environmental Management, Inc. | Northgate produced a Work Plan to conduct an in-situ PRB pilot test for perchlorate impacted groundwater at the Site. The scope of the Work Plan was to perform both laboratory bench-scale testing and a field-scale pilot test. The overall objective of the proposed pilot test was to examine the feasibility of the use of emulsified oil substrate injected into the subsurface as a PRB to degrade perchlorate in the groundwater; the rationale being that PRBs using edible oil-based electron donor substrates have been shown to be effective in remediation of perchlorate contaminated groundwater. Northgate referenced the Provisional Standard for perchlorate set by NDEP of 18 µg/L as a target for groundwater perchlorate concentrations following treatment by the proposed PRB, the distance from the PRB at which this would be achieved would be dependent upon the results of the field-scale pilot testing. The tests were conducted with the following specific objectives: <ul style="list-style-type: none"> • To determine the effective retention of EOS® 598B42 and lecithin-modified EOS® 598B42 emulsified oil onto Site-specific soils; • To chemically analyze the Site soil and groundwater to determine concentrations of metals and competing electron acceptors; • To perform leachability tests on the Site derived soil using deionized water to determine a baseline for adsorbed metals stability; • To establish the change in oxidation-reduction potential by adding EOS® 598B42 electron donor substrate to the Site derived soil and groundwater in the presence of indigenous bacteria, perchlorate and competing electron acceptors; • To determine the rate of perchlorate reduction in the test reactors; and • To determine the effect of oxidation-reduction potential on metals stability. | Northgate drilled one borehole in the location of the proposed PBR (I-2) to a depth of 40 ft bgs and recovered both soil cuttings and groundwater from the open borehole for use in the bench scale tests. The untreated groundwater was analyzed for metals and perchlorate concentrations and found to contain 25.7 mg/L perchlorate. Northgate concluded that a maximum effective oil retention ratio of 0.02 g/g for EOS® 598B42 and 0.06 g/g for lecithin –modified EOS® 598B42, which exceeded the minimum retention of 0.001 g/g, was required to achieve the pilot test objectives. Batch tests were then undertaken to assess the behavior of metals when the soil, saturated with groundwater was exposed to EOS® 598B42 in the presence of perchlorate and competing electron acceptors. Northgate concluded that the addition of EOS® 598B42 stimulated indigenous bacteria to anaerobically biodegrade perchlorate without significant mobilization of arsenic. The additon of 2 to 4 milliliter (mL) of EOS® 598B42 per liter of groundwater led to removal of perchlorate to below the laboratory reporting limit within 14 days. Northgate asserted that the evolution of dissolved arsenic would not be expected to occur in the field due to a constant flux of dissolved oxygen, nitrate, chlorate and perchlorate entering the PRB, a condition that was not possible to be created in the jar testing that was performed. Northgate did not progress to a field-scale trial of a PRB. |

TABLE 2
Well Construction Details for Existing Wells
Candidate Field-Scale PRB Pilot Test Location

| Monitoring Well ID | Well Diameter (inches) | Drilling Method | Well Material | Screened Zone | Date Completed | Total Depth (feet bgs) | Top of Screen Screen Depth (feet bgs) |
|--------------------|------------------------|-------------------|---------------|---------------|----------------|------------------------|---------------------------------------|
| MW-K5 | 2 | Unknown | Unknown | 28.5-43.5 | 4/2/1998 | 43.5 | 28.5 |
| PC-100 | 2 | Hollow Stem Auger | PVC | 8.5-38.5 | 5/18/2000 | 39 | 8.5 |
| PC-100R | 2 | Unknown | PVC | 15-40 | 8/16/2000 | 40.5 | 15 |
| PC-103 | 2 | Unknown | PVC | 9-29 | 2/3/2001 | 29.5 | 9 |
| PC-2 | 2 | Hollow Stem Auger | PVC | 16.7-31.7 | 3/13/1998 | 32 | 16.7 |
| PC-53 | 2 | Hollow Stem Auger | PVC | 13-32.5 | 5/4/1998 | 33 | 13 |
| PC-98 | 4 | Hollow Stem Auger | PVC | 13.5-33 | 5/17/2000 | 33.5 | 13.5 |
| PC-98R | 4 | Unknown | PVC | 20-35 | 8/8/2000 | 40.5 | 20 |
| PC-1 | 2 | Hollow Stem Auger | PVC | 14.7-29.7 | 3/24/1998 | 32 | 29.7 |
| PC-4 | 2 | Hollow Stem Auger | PVC | 17.7-42.7 | 3/24/1998 | 45 | 42.7 |

TABLE 3
Summary of Ground Water Indicator Parameters
Vicinity of Candidate Field-Scale PRB Test Location

| | Well | Water Level (ft msl) | Chlorate (mg/L) | Nitrate (mg/L) | Sulfate (mg/L) | DO (mg/L) | ORP (mV) | pH (s.u.) | TOC (ug/L) | Alkalinity (ug/L as CaCO ₃) | Perchlorate (mg/L) | TDS (mg/L) | Cr Total (mg/L) |
|-----------------------|-------------------|----------------------|-----------------|----------------|----------------|------------|-------------|-----------|------------|---|--------------------|------------|-----------------|
| NORTH OF BARRIER WALL | M-98 | 184 | 25 | 9.4 | 0.3418 | 2.6 as N | 1100 | | 7.4 to 8 | 474 | 2473 | | |
| | M-100 | 79.6 to 92.9 | 85 to 108 | 94 | 0.3418 to 3.4 | 12.85 as N | 3520 | | 7.1 to 8 | 474 | 2473 | | |
| | M-155 | | 1.94 | 86.1 | 8.07 | | | | | | | | |
| | Regional Values** | | <100 to 500 | <25 to 50 | | 0.1 – 1 | -100 to 100 | | | | 100 to 250 | 5000 | 0.1 to 1 |
| SOUTH OF PRB LOCATION | ARP-4A | 1587.04 | | | | | | | | | 27 | 4600 | 0.013 |
| | ARP-5A | 1583.73 | | | | | | | | | 22 | 6600 | 0.068 |
| | ARP-6B | 1583.62 | | | | | | | | | 31 | 9500 | 0.18 |
| | ARP-7 | 1583.26 | | | | | | | | | 4.9 | 6700 | 0.038 |
| NEAR PRB LOCATION | MW-K5 | 1567.11 | 23 | 13 | | | | | | | 22 | 7400 | 0.053 |
| | PC-103 | 1575.62 | 2.3 | 5.8 | | | | | | | 18 | 5200 | <0.01 |
| | PC-98R | 1570.46 | | | | | | | | | 26 | 7200 | 0.054 |
| | PC-53 | 1568.43 | | | | | | | | | 3.3 | 4900 | 0.046 |
| | PC-2 | 1572.47 | 18 | 13 | | | | 7.4 | | | 3.35 | 5100 | 0.0075 |
| | Regional Values** | | 10 to 50 | 5 to ~10 | | | | | | | 1 to 20 | 5000 | 0.02 to 0.05 |
| NORTH OF PRB LOCATION | PC-56 | 1554.52 | | | | | | | | | 16 | 5200 | 0.1 |
| | PC-58 | 1554.01 | | | | | | | | | 6.9 | 6100 | 0.085 |
| | PC-59 | 1554.92 | | | | | | | | | 7.3 | 4000 | 0.034 |
| | PC-60 | 1554.86 | | | | | | | | | 7.3 | 3400 | 0.032 |
| | PC-62 | 1555.38 | | | | | | | | | 2.6 | 3400 | 0.0083 |
| | PC-68 | 1555.87 | | | | | | | | | 0.58 | 2500 | 0.045 |

Notes:

Chlorate & nitrate data is taken from ENVIRON's 2011 Annual Performance Report.

Cr and TDS values are from the ENVIRON 2012 Annual Report.

Highest concentrations over sampling period are presented.

**Interpreted from map isoconcentration lines.

TABLE 4
Summary of Ground Water Quality Results
(Northgate, December 2010)

| Parameter | Units | Results |
|---|-------|------------|
| <i>Dissolved Metals</i> | | |
| Antimony | mg/L | < 0.005 |
| Arsenic (tot) | mg/L | 0.034 |
| Arsenic (recoverable) | mg/L | 0.0378 |
| Arsenic (III) | mg/L | < 0.000074 |
| Arsenic (V) | mg/L | 0.0319 |
| Beryllium | mg/L | < 0.004 |
| Cadmium | mg/L | < 0.005 |
| Chromium (total) | mg/L | < 0.005 |
| Chromium (VI) | mg/L | < 0.001 |
| Copper | mg/L | < 0.01 |
| Iron (tot) | mg/L | 1.6 |
| Iron (II) | mg/L | 0.11 |
| Lead | mg/L | < 0.005 |
| Mercury | mg/L | < 0.001 |
| Nickel | mg/L | 0.014 |
| Selenium | mg/L | 0.01 |
| Silver | mg/L | < 0.005 |
| Thallium | mg/L | < 0.002 |
| Zinc | mg/L | < 0.1 |
| <i>Anionic Species and Other Parameters</i> | | |
| Chloride | mg/L | 2200 |
| Chlorate | mg/L | 28 |
| Perchlorate | mg/L | 25.7 |
| Nitrate | mg/L | 8.1 |
| Sulfate | mg/L | 1400 |
| Sulfide | mg/L | < 0.1 |
| DO | mg/L | 8.5 |
| DOC | mg/L | 4.4 |
| ORP | mg/L | 146 |
| pH | mg/L | 7.42 |

**TABLE 5
Summary of Selected PRB Case Studies**

| Site Name | Technology | Hydraulic Details | Location | Contaminants | Pilot/Full Scale | Cost | Performance | Longevity |
|--|---|---|--------------------|--|---|--|---|--|
| Unidynamics Phoenix Inc | Nano Scale Zero Valent Iron injection | Deep injection | Goodyear, AZ | TCE, perchlorate | In field pilot test | N/A | Experienced TCE rebound; hydrogen concentrations increased | Not Available |
| Aerojet General Corporation | In situ horizontal flow treatment barrier wells using citric acid for electron donor to stimulate bioremediation | Used recirculation of water from Deep Aquifer Region to shallower aquifer region back to Deep. Hydraulic conductivity of 15 ft/day Injections occurred from 46-61 ft bls for upper section, and 80-100 ft bls for lower section | Rancho Cordova, CA | Perchlorate impacted groundwater (co-contaminants include nitrate and TCE). There were concerns about mobilizing Mn and Fe. | In field pilot / demonstration scale test | Capital: \$403,205 O&M for 30 yrs: \$784,944 Long term monitoring: \$271,342 | Perchlorate concentrations decreased an average 95% from start to Day 275. Shallow well perchlorate concentrations went from 2230 µg/L to 90 µg/L. Deep well perchlorate concentrations decreased from 3722 µg/L to 1780 µg/L. Mn and Fe were not mobilized. Showed rebound of perchlorate between phased operations. | Long term operation is feasible |
| Alliant Techsystems, Inc | Emulsified Oil Substrate (EOS) Biobarrier | Shallow injections (15 bgs). 50 feet wide GW flow velocity = 100 ft/year, Ground permeability = 29 ft/day | Elkton, MD | Perchlorate and chlorinated solvents | In field pilot study | A 200 ft PRB estimated at \$38,000 or \$19/ft. | Perchlorate concentrations reduced from 9,000 µg/L to <4 µg/L. No rebound of perchlorate noted after initial injection 2.5 years later. Hydraulic conductivity reduced potentially due to biomass growth. | Effectiveness of barrier lasted 2.5 to 3.5 years |
| Naval Weapons Industrial Reserve Plant | Biobarrier (mushroom compost, pine wood chips, soybean oil, and 1" crushed limestone) with injected emulsified oil substrate (EOS) solution | Shallow | McGregor, TX | Perchlorate contaminated ground water | Full scale | \$200 per square foot, or less than \$15 per linear foot | Reduced perchlorate concentration from 1,000 µg/L to <2 µg/L | Not Available |

**TABLE 5
Summary of Selected PRB Case Studies**

| Site Name | Technology | Hydraulic Details | Location | Contaminants | Pilot/Full Scale | Cost | Performance | Longevity |
|---|--|--|----------------------|---|------------------|--|--|---|
| Whiteman AFB | Biobarrier (organic mulch and clean sand) | Shallow (10 to 20 ft deep) | Near Kansas City, MO | CVOCs, primarily TCE (groundwater contaminants) | Full Scale | Total \$74,000 or \$275 per linear foot, less than \$20 per vertical foot | Monitoring shows CVOC degradation within the biobarrier, CVOC concentrations in downgradient wells are 88% lower than in upgradient wells | Continued to show effective treatment after 2 years of operation |
| Confidential Industrial Site research funded by ESTCP | Emulsified oil (EOS) injected to form a Permeable Reactive Barrier (PRB) | Shallow (10 ft deep, 10 ft wide, 50 ft long). Shallow hydraulic gradient of 0.003 ft/ft, hydraulic conductivity averaged between 22 to 40 ft/day. Assuming 30% porosity, ground water velocity was approximately 80 ft/year. Average GW velocity in specific test area calculated to be 400 ft/year. | Eastern Maryland | Perchlorate and TCE plume | Pilot | \$226/cu yd; \$8.39 cu ft Full scale PRB at the site estimated at \$38,000, or \$0.02/gal treated 30 yr life cycle cost estimated at \$161,400 | Dissolved iron increased from non-detect to a maximum of 78 mg/L, manganese also increased. Perchlorate rebound experienced 4 months after injection, but concentrations continued to decrease for 7 more months. Average removal efficiency of perchlorate was 97% (reduced from 10,000 µg/L to <4 µg/L) 10' downgradient of injection wells. | At least 3.5 years (monitoring ended after 3.5 years) |
| Charleston Naval Weapons Station | EOS injection, plus Vitamin B-12. 28 months after initial injection, a buffered EOS was injected. | Shallow (10 ft deep), used a small grid configuration Aquifer between 0.5 ft and 6 ft bgs Hydraulic conductivity of surficial aquifer 1 to 10 ft/day | Goose Creek, S.C. | TCE | Pilot | \$325/ cu yd for direct injection; \$428/ cu yd for a recirculation design | Ground water was oxidative, determined this is not optimal for biodegradation. TCE was reduced by 76 to 86% lower through test cell groundwater than in background groundwater. TCE reduced by up to 96% to 99% after buffered EOS injection. | Initial injection treatment continued to work for at least 28 months, second injection treatment prolonged treatment out to 3.5 years (end of monitoring) |
| Naval Surface Warfare Center | Recirculation treatment using sodium lactate as electron donor, with a sodium bicarbonate buffer | Average hydraulic conductivity of 5.2 ft/day and 2.7 ft/day in Mainland and dLittoral zones | Indian Head, MD | Perchlorate | Pilot | 30 year total cost \$2,243,853 including monitoring. First year cost \$311,837 | Reduced from 170,000 µg/L to below detection (5 µg/L) | Biobarrier can be continually replenished by sodium lactate injection; study lasted 20 weeks |

**TABLE 5
Summary of Selected PRB Case Studies**

| Site Name | Technology | Hydraulic Details | Location | Contaminants | Pilot/Full Scale | Cost | Performance | Longevity |
|------------------------------|--|---|-------------|---|------------------|---|--|--|
| Confidential Industrial Site | Hardwood mulch biowall with pea gravel to reduce compaction (a 50/50 mix) (in situ passive permeable reactive barrier) | PRB installed to a depth of 25 ft bgs to target the permeable gravel zone at that depth. Ground water flow velocity of 25 to 51 ft/year. | Undisclosed | Perchlorate (impacted soil and groundwater) | Full scale | Used one pass trenching, cost \$185/linear foot | Perchlorate reduction seen at least 15 ft downgradient of the PRB. Ferrous Iron measurements increasing since install; reducing conditions have developed. Perchlorate concentrations immediately downgradient or PRBT reduced to non-detect (<4 µg/L) from a range of 8,000 to 13,000 µg/L | Documented operation of 2.5 years, anticipated to work as an effective barrier for "at least the next 3 – 4 years" |
| Grain Silo Facility Kansas | EHC injection from Adventus | Ground water table encountered at 23 ft bgs Ground water velocity averages 1.8 ft/day | Kansas | Carbon tetrachloride and its catabolites | Pilot | \$37/ft ² | Carbon tetrachloride was reduced by up to 99.5%; initial concentration was 1,000 ppb, final concentration measured was 5 ppb | Documented operation of over 4 years with continuous removal of carbon tetrachloride at or over 94% |

TABLE 6
Analytical Parameters PRB Monitoring - PRB Field-Scale Pilot

Baseline and Quarterly Sampling Parameters

| Parameter | Method |
|---|--|
| Temperature, pH, Conductivity, DO and ORP | Portable field instrument |
| Groundwater elevation | Portable field instrument |
| Turbidity | USEPA Method 180.1 |
| Total Organic Carbon (TOC) | USEPA Method 415.1 |
| Dissolved Organic Carbon (DOC) | USEPA Method 415.1 |
| Total Nitrogen | USEPA Method 351.1 |
| Total Phosphorous | USEPA Method 365.1 |
| Alkalinity | USEPA Method 310.2 |
| Hardness | USEPA Method 130.1 |
| Total Dissolved Solids (TDS) | USEPA Method 160.1 |
| Perchlorate | USEPA Method 314 |
| Chlorate / Chlorite | USEPA Method 300.1 |
| Chloride | USEPA Method 300.0 |
| Dissolved Metals (Ag, As, B, Ba, Be, Ca, Cd, Cr, Co, Cu, Fe, Hg, K, Mo, Mg, Mn, Na, Ni, Pb, Sb, Se, Ti, Zn, and U) | USEPA Methods 6010/6020/7400/200.8 |
| Ferrous and Ferric Iron | HACH Method 8008 and 8147 |
| Nitrate / Nitrite | USEPA Method 300.0 |
| Sulfate | USEPA Method 300.0 |
| Sulfide | HACH Method 8131 (USEPA Methylene Blue Method) |
| Methane | |

Parameters for Performance Monitoring

| Parameter | Method |
|---|--|
| Temperature, pH, Conductivity, DO and ORP | Portable field instrument |
| Groundwater Elevation | Portable field instrument |
| Perchlorate | USEPA Method 314 |
| Chlorate / Chlorite | USEPA Method 300.1 |
| Chloride | USEPA Method 300.0 |
| Arsenic | USEPA Method 200.8 |
| Iron | USEPA Method 236.1/236.2 |
| Total Organic Carbon (TOC) | USEPA Method 415.1 |
| Nitrite / Nitrate | USEPA Method 300.0 |
| Sulfate | USEPA Method 300.0 |
| Sulfide | HACH Method 8131 (USEPA Methylene Blue Method) |
| Volatile Fatty Acids | Method SW8015 Modified |
| Hexavalent chromium | USEPA Method 7199 |

Abbreviations:

DO - Dissolved Oxygen

ORP - Oxidation-Reduction Potential

Appendix A

Boring Logs and Well Construction Diagrams

EXPLORATION LOG MW-K5

CONFIDENTIAL

| | |
|--|-----------------------------------|
| PROJECT: <u>FORMER PEPCON FACILITY</u> | PROJECT NO.: <u>97664V1</u> |
| SITE LOCATION: <u>SEE SITE PLAN</u> | EXPLORATION DATE: <u>4-2-98</u> |
| EXPLORATION SIZE (diameter): <u>2" MONITORING WELL</u> | EQUIPMENT: <u>MOBILE B-61-HDX</u> |
| G.S. ELEVATION: <u>1592.49</u> | LOGGED BY: <u>S. JOHNSON</u> |
| INITIAL DEPTH TO WATER: <u>24</u> | DATE MEASURED: <u>4-2-98</u> |
| FINAL DEPTH TO WATER: <u>18.7</u> | DATE MEASURED: <u>4-3-98</u> |

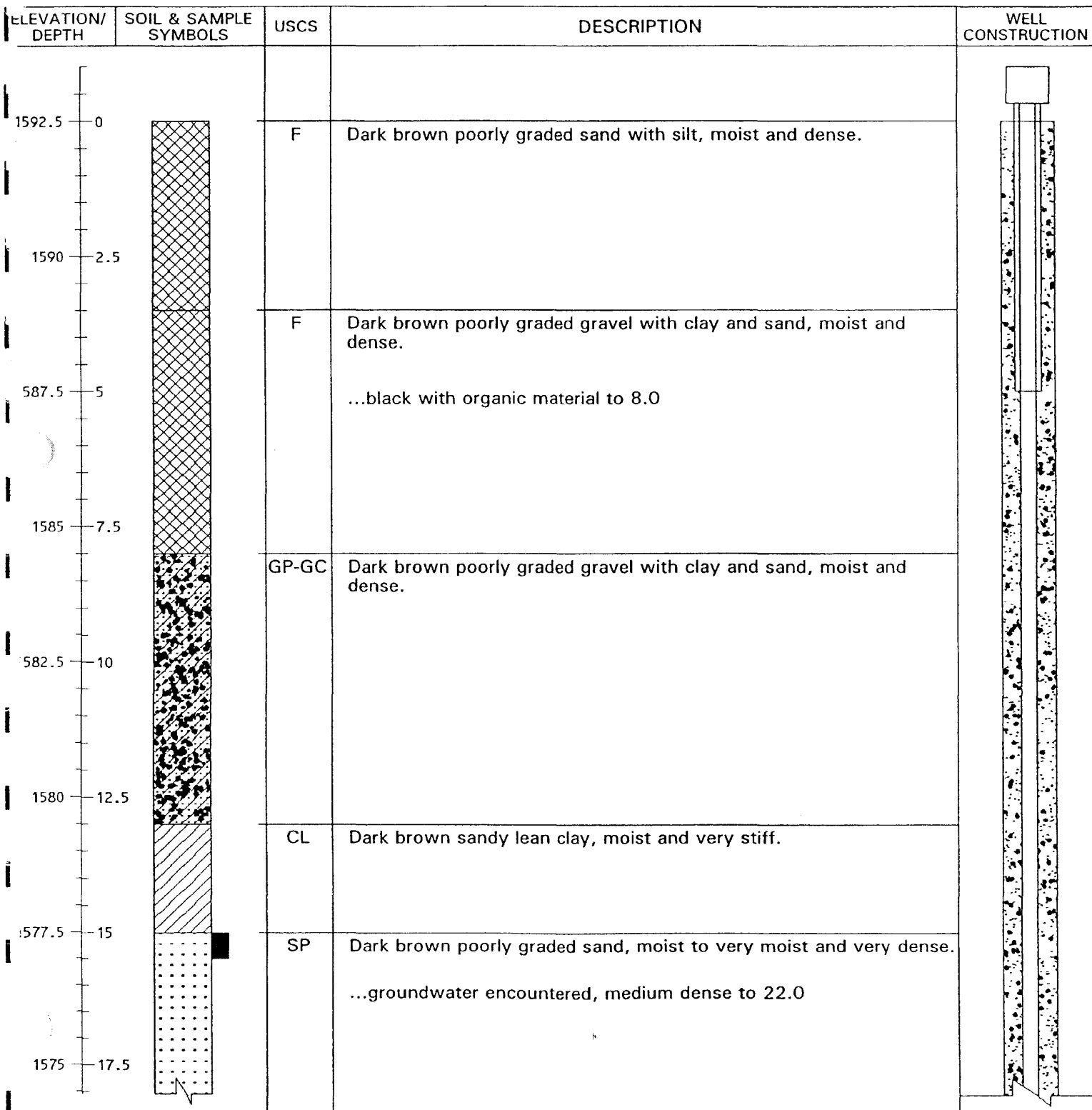

EXPLORATION LOG MW-K5

CONFIDENTIAL

| ELEVATION/ DEPTH | SOIL & SAMPLE SYMBOLS | USCS | DESCRIPTION | WELL CONSTRUCTION |
|---|--------------------------|---|---|----------------------|
| 572.5 — 20 1570 — 22.5 1567.5 — 25 1565 — 27.5 562.5 — 30 1560 — 32.5 1557.5 — 35 1555 — 37.5 1552.5 — 40 | | SP-SC CL | ...gravel lens to 22.0 Dark reddish brown clayey sand, wet and medium dense to dense. ...gravel lens to 27.5 ... dense to 32.5 ...gravel lens to 32.5 ...dense to very dense to 35.0 ...medium dense to 38.0 White and green mottled sandy lean clay, moist to very moist and stiff. | |

EXPLORATION LOG MW-K5

CONFIDENTIAL

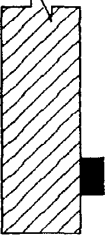
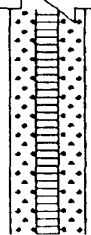
| ELEVATION/ DEPTH | SOIL & SAMPLE SYMBOLS | USCS | DESCRIPTION | WELL CONSTRUCTION |
|--|---|------|-----------------------------------|---|
| <div style="display: flex; flex-direction: column; align-items: center;"> <div style="margin-bottom: 10px;">1550 — 42.5</div> <div style="margin-bottom: 10px;">1547.5 — 45</div> <div style="margin-bottom: 10px;">1545 — 47.5</div> <div style="margin-bottom: 10px;">1542.5 — 50</div> <div style="margin-bottom: 10px;">1540 — 52.5</div> <div style="margin-bottom: 10px;">1537.5 — 55</div> <div style="margin-bottom: 10px;">1535 — 57.5</div> <div style="margin-bottom: 10px;">1532.5 — 60</div> <div style="margin-bottom: 10px;">1530 — 62.5</div> </div> |  | | <p>END OF BORING AT 43.5 FEET</p> |  |

SOIL BORING LOG KM-5655-B

| KERR-McGEE CORPORATION Hydrology Dept. - S&EA Division | | KM SUBSIDIARY KMC LLC | | LOCATION HENDERSON, NV | | BORING NUMBER PC 100 | | | | |
|--|--|---|---|----------------------------------|-----------|--------------------------------|--|------------------------------------|------|-------------------------------|
| DEPTH IN FEET | LITHOLOGIC DESCRIPTION | GRAPHIC LOG | UNIFIED SOIL FIELD CLASS. | BLOWS PER 6" | PID (ppm) | SOIL SAMPLE | | | | REMARKS OR FIELD OBSERVATIONS |
| | | | | | | NO. | TYPE | DEPTH | REC. | |
| 5 | 0-18 gravelly SAND, mod yell brn (10YR 5/4). 10% silt, 25% volc granules & sm pebbles up to 1" | [Symbol] | SW | | | | | | | |
| 10 | | | | | | | | | | |
| 15 | | | | | | | | | | damp @ 16' |
| 20 | 18-29 silty sdy GRAVEL 14 brn (5YR 5/4). 20-25% silt, 20-25% poorly sorted, SA-SF, vf-vc sd | [Symbol] | SW | | | | | | | |
| 25 | 50% volc granules and pebbles to 3" Locally hard thin caliche zones | [Symbol] | | | | | | | | ▽ @ 25' |
| 29 | 29-36 silty SAND, lt. yell brn (10YR 6/4). vf-fg w/com m-cg, SR-SA, 25-30% silt. Very calcareous. Minor m-vc size caliche nodules | [Symbol] | SM | | | | | | | |
| 36 | 36-45 silty grav SAND, mod yell brn (10YR 5/4) 25% silt, 25% volc granules | [Symbol] | SW | | | | | | | |
| EXPLANATION | ▼ Water Table (24 Hour) ▽ Water Table (Time of Boring) PID Photoionization Detection (ppm) NO. Identifies Sample by Number TYPE Sample Collection Method | | GRAPHIC LOG LEGEND [Symbol] CLAY [Symbol] DEBRIS FILL [Symbol] SILT [Symbol] HIGHLY ORGANIC (PEAT) [Symbol] SAND [Symbol] SANDY CLAY [Symbol] GRAVEL [Symbol] CLAYEY SAND [Symbol] SILTY CLAY [Symbol] _____ [Symbol] CLAYEY SILT [Symbol] _____ | | | | DATE DRILLED 5-18-00 PAGE 1 of 2 | | | |
| | [Symbol] SPLIT-BARREL [Symbol] THIN-WALLED TUBE | [Symbol] AUGER [Symbol] CONTINUOUS SAMPLER | [Symbol] ROCK CORE [Symbol] NO RECOVERY | DRILLED BY HSA | | | | DRILLED BY COMPLIANCE | | |
| | | | | LOGGED BY ED KRISH | | | | EXISTING GRADE ELEVATION (FT AMSL) | | |
| | DEPTH Depth Top and Bottom of Sample REC. Actual Length of Recovered Sample in Feet | | | LOCATION OR GRID COORDINATES | | | | | | |

SOIL BORING LOG KM-5655-B

| | | | |
|---|--------------------------|---------------------------|-------------------------|
| KERR-McGEE CORPORATION Hydrology Dept. - S&EA Division | KM SUBSIDIARY KMC LLC | LOCATION HENDERSON, NV | BORING NUMBER PC 100 |
|---|--------------------------|---------------------------|-------------------------|

| DEPTH IN FEET | LITHOLOGIC DESCRIPTION | GRAPHIC LOG | UNIFIED SOIL FIELD CLASS. | BLOWS PER 6" | PID (ppm) | SOIL SAMPLE | | | | REMARKS OR FIELD OBSERVATIONS |
|---------------|---|-------------|---------------------------|--------------|-----------|-------------|------|-------|------|-------------------------------|
| | | | | | | NO. | TYPE | DEPTH | REC. | |
| 45 | and sm pebbles; vf-vc sd 42-45 silty gravelly SAND, gry oran pink (SYR 6/2) 10% clay, 20% silt, 20% volc & ls granules to 1/8"-1/2" dissem throughout Very calcareous w/ minor sm. caliche nodules TD 45' | | SW | | | | | | | MC not reached |

| | | | | | |
|--|---|---------------------------|-----------------------|------------------------------------|-----------------------|
| EXPLANATION | Water Table (24 Hour) | GRAPHIC LOG LEGEND | | DATE DRILLED 5-18-00 | PAGE 2 of 2 |
| | Water Table (Time of Boring) | CLAY | DEBRIS FILL | DRILLING METHOD HSA | |
| | PID NO. Identifies Sample by Number TYPE Sample Collection Method | SILT | HIGHLY ORGANIC (PEAT) | DRILLED BY Compliance | |
| | SPLIT-BARREL | AUGER | SAND | SANDY CLAY | LOGGED BY ED KRISH |
| THIN-WALLED TUBE | CONTINUOUS SAMPLER | GRAVEL | CLAYEY SAND | EXISTING GRADE ELEVATION (FT AMSL) | |
| ROCK CORE | NO RECOVERY | SILTY CLAY | CLAYEY SILT | LOCATION OR GRID COORDINATES | |
| DEPTH: Depth Top and Bottom of Sample REC.: Actual Length of Recovered Sample in Feet | | | | | |

**KERR-McGEE CORPORATION
HYDROLOGY DEPARTMENT
MONITORING WELL INSTALLATION DIAGRAM**

FLUSH
MOUNT

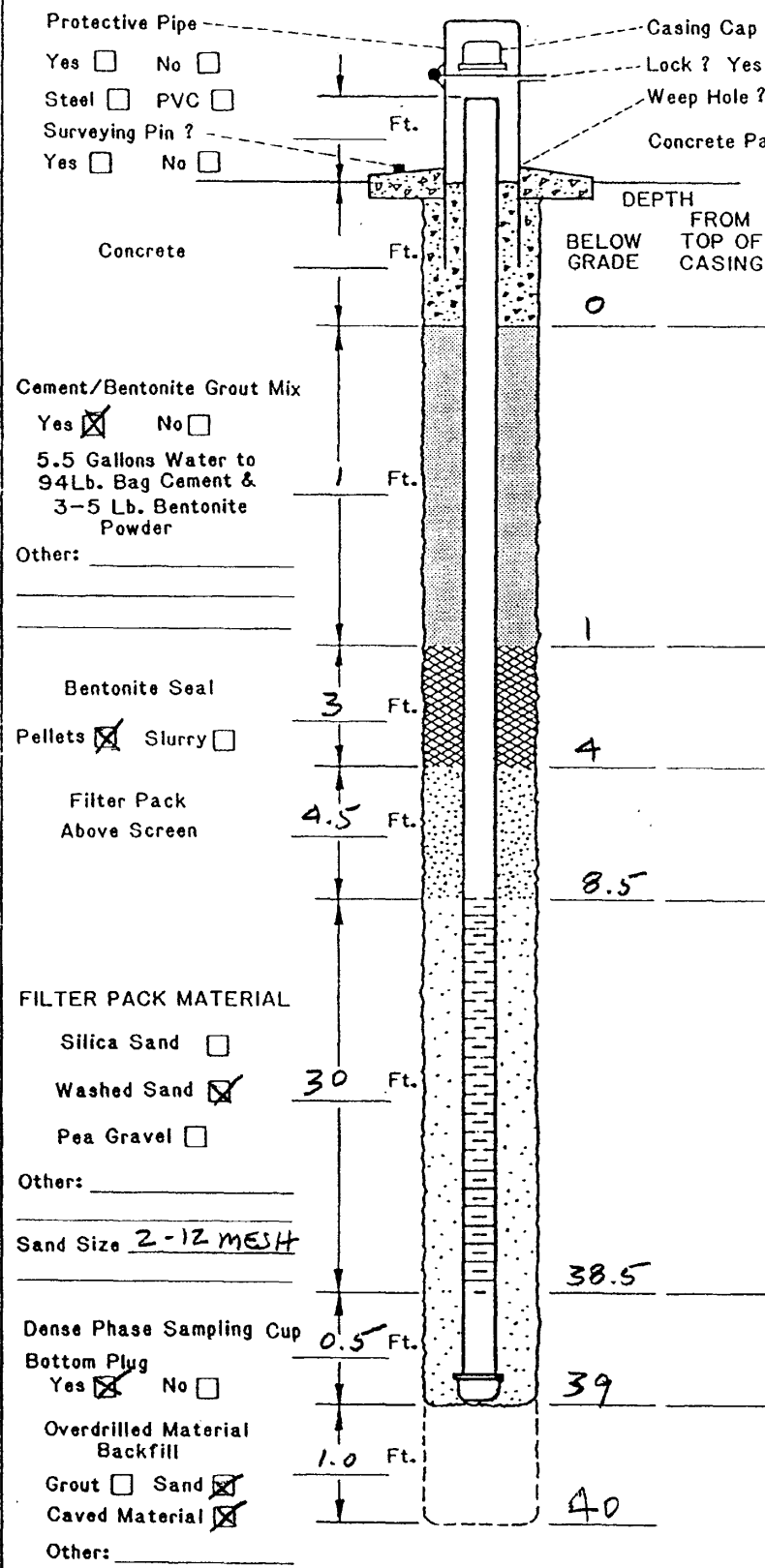

- DRILLING INFORMATION:**
- Borehole Diameter = 8 Inches.
 - Were Drilling Additives Used? Yes No
Revert Bentonite Water
Solid Auger Hollow Stem Auger
 - Was Outer Steel Casing Used? Yes No
Depth = _____ to _____ Feet.
 - Borehole Diameter for Outer Casing _____ Inches.

- WELL CONSTRUCTION INFORMATION:**
- Type of Casing: PVC Galvanized Teflon
Stainless Other _____
 - Type of Casing Joints: Screw-Couple Glue-Couple Other _____
 - Type of Well Screens: PVC Galvanized
Stainless Teflon Other _____
 - Diameter of Casing and Well Screens:
Casing 2 Inches, Screen 2 Inches.
 - Slot Size of Screens: 0.020
 - Type of Screen Perforation: Factory Slotted
Hacksaw Drilled Other _____
 - Installed Protector Pipe w/Lock: Yes No

- WELL DEVELOPMENT INFORMATION:**
- How was Well Developed? Bailing Pumping
Air Surging (Air or Nitrogen) Other _____
 - Time Spent on Well Development? _____
1.60 Minutes/Hours
 - Approximate Water Volume Removed? _____ Gallons
 - Water Clarity Before Development? Clear
Turbid Opaque
 - Water Clarity After Development? Clear
Turbid Opaque
 - Did Water have Odor? Yes No
If Yes, Describe _____
 - Did Water have any Color? Yes No
If Yes, Describe _____

WATER LEVEL INFORMATION:
Water Level Summary (From Top of Casing)
During Drilling 25 Ft. Date 5-18-00
Before Development 14.03 Ft. Date 5-19-00
After Development _____ Ft. Date _____

Driller/Firm COMPLIANCE Drill Rig Type Mobile B-59 Date Installed 5-18-00
Drill Crew LOYA Well No. PC 100 Kerr-McGee Hydrologist ED KRISH

SOIL BORING LOG KM-5655-B

| KERR-MCGEE CORPORATION Hydrology Dept. - S&EA Division | | KM SUBSIDIARY KMC LLC | LOCATION Henderson, NV | | BORING NUMBER PC100R | | | | | |
|---|---|---------------------------------|----------------------------------|--------------|--------------------------------|-------------|------|-------|------|--|
| DEPTH IN FEET | LITHOLOGIC DESCRIPTION | GRAPHIC LOG | UNIFIED SOIL FIELD CLASS. | BLOWS PER 6" | PID (ppm) | SOIL SAMPLE | | | | REMARKS OR FIELD OBSERVATIONS |
| | | | | | | NO. | TYPE | DEPTH | REC. | |
| 4 | 0-4 gravelly SAND, gry brn w/ 10-15% silt. 20-30% volc granules to pea gravel. vf-vc SA sd | | SW | | | | | | | start drilling @ 8:30 am finish @ 9:00 |
| 7 | 4-7 SAND, gry brn w/ 10% silt and 5-10% v. sm granules to 1/10". f-vc SA-SR sand. | | SW | | | | | | | |
| 9 | 7-9 sdy GRAVEL, brn, A-SA to 1". 30-35% vf-vc sand | | GW | | | | | | | |
| 11 | 7-9 sdy GRAVEL, brn, A-SA to 1". 30-35% vf-vc sand | | SW | | | | | | | damp @ 12' |
| 15 | 9-11 SAND, brn, w/ 10% silt + 5-10% v. sm gran. f-vc, SA sand | | GW | | | | | | | ∇ @ 18' |
| 20 | 11-25 sdy GRAVEL brn w/ 5-10% silt + 25-30% vf-vc, SR-SA sd. Grav. up to 2" (ave 1/10" - 3/4") volc w/ minor caliche coatings | | GW | | | | | | | |
| 25 | 25-27 SAND brn, mod silty (15-20%). Calcareous. w/ 10-15% sm volc granules vf-vc, SA-SR | | SW | | | | | | | |
| 27 | 25-27 SAND brn, mod silty (15-20%). Calcareous. w/ 10-15% sm volc granules vf-vc, SA-SR | | GW | | | | | | | |
| 30 | 27-30 sdy GRAVEL, brn, volc up to 2" (ave 3/4") clean, vf-vc sd | | SW | | | | | | | |
| 35 | 30-35 SAND, brn, vf-c w/ minor vc, SA-SR. 10-15% silt, calcareous | | SM | | | | | | | |
| 38 | 35-38 silty SAND/sdy SILT var amts of silt in vf-fg SA-SR sd | | GM/SM | | | | | | | |

EXPLANATION

- Water Table (24 Hour)
- Water Table (Time of Boring)
- PID Photoionization Detection (ppm)
- Identifies Sample by Number
- Sample Collection Method
- SPLIT-BARREL
- AUGER
- ROCK CORE
- THIN-WALLED TUBE
- CONTINUOUS SAMPLER
- NO RECOVERY

DEPTH Depth Top and Bottom of Sample
REC. Actual Length of Recovered Sample in Feet

GRAPHIC LOG LEGEND

- CLAY
- SILT
- SAND
- GRAVEL
- SILTY CLAY
- CLAYEY SILT
- DEBRIS FILL
- HIGHLY ORGANIC (PEAT)
- SANDY CLAY
- CLAYEY SAND

DATE DRILLED **8-16-00** PAGE **1 of 2**

DRILLING METHOD **PERCUSSION**

DRILLED BY **LAYNE**

LOGGED BY **ED KRISH**

EXISTING GRADE ELEVATION (FT. AMSL)

LOCATION OR GRID COORDINATES

SOIL BORING LOG KM-5655-B

| KERR-McGEE CORPORATION Hydrology Dept. - S&EA Division | | KM SUBSIDIARY KMC LLC | | LOCATION HENDERSON, NV | | BORING NUMBER PC100R | | | | |
|---|--|---------------------------------|---------------------------|----------------------------------|-----------|--------------------------------|------|-------|------|-------------------------------|
| DEPTH IN FEET | LITHOLOGIC DESCRIPTION | GRAPHIC LOG | UNIFIED SOIL FIELD CLASS. | BLOWS PER 6" | PID (ppm) | SOIL SAMPLE | | | | REMARKS OR FIELD OBSERVATIONS |
| | | | | | | NO. | TYPE | DEPTH | REC. | |
| 40.5 | 38-40.5 gravelly silty SAND, brn. 20-25% silt and 10-20% volc sm granules. SA-SR vf-vc sd. 40.5-41.5 lt grn silty CLAY w/ gyp xtals TD 41.5' | CL | | | | | | | | MC @ 40.5' |
| 45 | | | | | | | | | | |

| | | | | | | | | |
|--|------------------|---|---------------------------|------------------|------------------|-------------------------------------|------------------|-------------|
| EXPLANATION | ▼ | Water Table (24 Hour) | GRAPHIC LOG LEGEND | | DATE DRILLED | PAGE | | |
| | ▽ | Water Table (Time of Boring) | | | [diagonal lines] | CLAY | [cross-hatch] | DEBRIS FILL |
| | PID | Photoionization Detection (ppm) | [horizontal lines] | SILT | [wavy lines] | HIGHLY ORGANIC (PEAT) | [diagonal lines] | SANDY CLAY |
| | TYPE | Identifies Sample by Number Sample Collection Method | [dots] | SAND | [diagonal lines] | CLAYEY SAND | [empty box] | |
| [diagonal lines] | SPLIT-BARREL | [vertical bar] | AUGER | [diagonal lines] | NO RECOVERY | DRILLED BY LAYNE | | |
| [vertical bar] | THIN-WALLED TUBE | [vertical bar] | CONTINUOUS SAMPLER | [diagonal lines] | NO RECOVERY | LOGGED BY ED KRISH | | |
| [diagonal lines] | ROCK CORE | [diagonal lines] | NO RECOVERY | [diagonal lines] | NO RECOVERY | EXISTING GRADE ELEVATION (FT. AMSL) | | |
| DEPTH Depth Top and Bottom of Sample | | | [diagonal lines] | | CLAYEY SILT | LOCATION OR GRID COORDINATES | | |
| REC. Actual Length of Recovered Sample in Feet | | | [diagonal lines] | | CLAYEY SILT | | | |

DATE DRILLED: 8-16-00
 PAGE: 2 of 2
 DRILLING METHOD: PERCUSSION
 DRILLED BY: LAYNE
 LOGGED BY: ED KRISH
 EXISTING GRADE ELEVATION (FT. AMSL):
 LOCATION OR GRID COORDINATES:

**KERR-McGEE CORPORATION
HYDROLOGY DEPARTMENT
MONITORING WELL INSTALLATION DIAGRAM**

FLUSH MOUNT

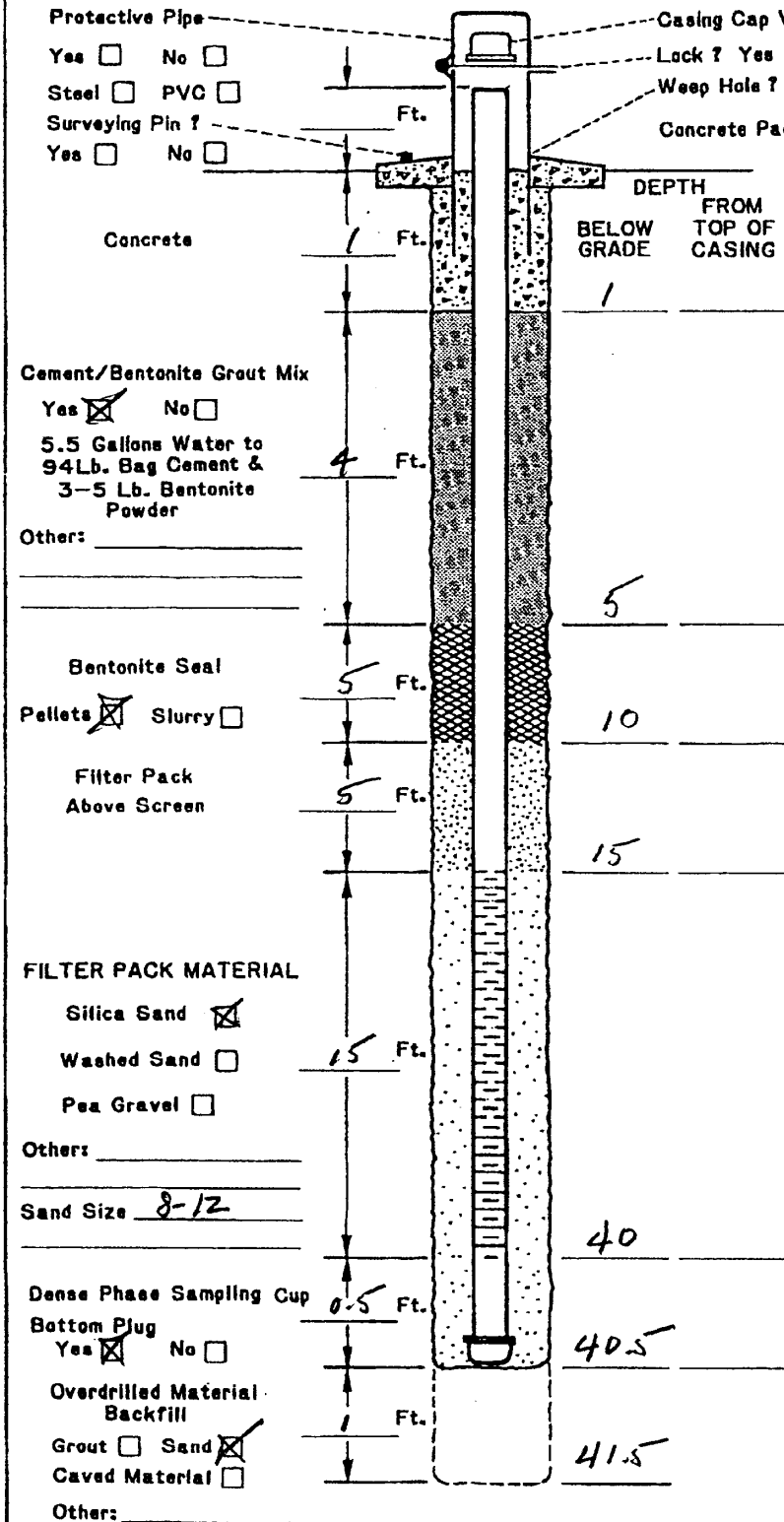

- DRILLING INFORMATION:**
- Borehole Diameter = 9 Inches.
 - Were Drilling Additives Used? Yes No
 Revert Bentonite Water
 Solid Auger Hollow Stem Auger
 - Was Outer Steel Casing Used? Yes No
 Depth = _____ to _____ Feet.
 - Borehole Diameter for Outer Casing _____ Inches.
- WELL CONSTRUCTION INFORMATION:**
- Type of Casings: PVC Galvanized Teflon
 Stainless Other _____
 - Type of Casing Joints: Screw-Couple Glue-Couple Other _____
 - Type of Well Screens: PVC Galvanized
 Stainless Teflon Other _____
 - Diameter of Casing and Well Screen:
 Casing 2 Inches, Screen 2 Inches.
 - Slot Size of Screens: 0.040
 - Type of Screen Perforation: Factory Slotted
 Hackaw Drilled Other _____
 - Installed Protector Pipe w/Locks: Yes No
- WELL DEVELOPMENT INFORMATION:**
- How was Well Developed? Bailing Pumping
 Air Surging (Air or Nitrogen) Other _____
 - Time Spent on Well Development? 2 1 Minutes/Hours
 - Approximate Water Volume Removed? _____ Gallons
 - Water Clarity Before Development? Clear
 Turbid Opaque
 - Water Clarity After Development? Clear
 Turbid Opaque
 - Did Water have Odor? Yes No
 If Yes, Describe Pesticide
 - Did Water have any Color? Yes No
 If Yes, Describe _____
- WATER LEVEL INFORMATION:**
 Water Level Summary (From Top of Casing)
 During Drilling 18' Ft. Date 8-16-00
 Before Development _____ Ft. Date _____
 After Development 13.64 Ft. Date 8-17-00

Driller/Firm HORMANN/LAYNE Drill Rig Type AP-1000 Date Installed 8-16-00
 Drill Crew _____ Well No. PC 100R Kerr-McGee Hydrologist Ed Krish

SOIL BORING LOG KM-5655-B

| KERR-McGEE CORPORATION Hydrology Dept. - S&EA Division | | KM SUBSIDIARY KMC LLC | | LOCATION Henderson NV | | BORING NUMBER PC 103 | | | | |
|---|---|---------------------------------|---------------------------|---------------------------------|-----------|--------------------------------|------|-------|------|-------------------------------|
| DEPTH IN FEET | LITHOLOGIC DESCRIPTION | GRAPHIC LOG | UNIFIED SOIL FIELD CLASS. | BLOWS PER 6" | PID (ppm) | SOIL SAMPLE | | | | REMARKS OR FIELD OBSERVATIONS |
| | | | | | | NO. | TYPE | DEPTH | REC. | |
| 6 | 0-6 BERM. Com construction material | / | | | | | | | | |
| 10 | 6-10 SAND, gravelly, brn (5R5/4), 10-20% volc pea gravel to 1/4" in vf-vc, A-SR sd | [Symbol] | SW | | | | | | | |
| 15 | 10-17' GRAVEL, sdy, silty, brn, 10-20% silt & 20-30% vf-vc, SA-SR sd in volc gravel to 1". Sl. calcareous. [Prob. series of fining-up. alluvial beds] | [Symbol] | GM | | | | | | | damp @ 14' |
| 17 | 16-17' Gravel to 4" | [Symbol] | | | | | | | | ▽ |
| 20 | 17-29 Gravel, sl. sdy tr silt. 10-15% vf-vc sd, A-SR, volc SA-SR pea gravel to 1/2" w/ local thin beds up to 4" | [Symbol] | GP | | | | | | | WTR @ 17' |
| 25 | 25-28' com lg volc gravel to 4" | [Symbol] | | | | | | | | |
| | 28-29' gravel w/ 20-30% silt in matrix | [Symbol] | | | | | | | | |
| 30 | 29-30' CLAY, silty & CLAY, lt grngry (5GY8/1), 10-20% silt in matrix, non-calcareous, tr-sp gypsum | [Symbol] | CL | | | | | | | MC @ 29' |
| | TD 30' | | | | | | | | | |

| | | | | | | | |
|--------------------|--------------------|-------------------------------------|---------------------------|--|------------|--|-----------------------|
| EXPLANATION | | Water Table (24 Hour) | GRAPHIC LOG LEGEND | | CLAY | | DEBRIS FILL |
| | | Water Table (Time of Boring) | | | SILT | | HIGHLY ORGANIC (PEAT) |
| | | PID Photoionization Detection (ppm) | | | SAND | | SANDY CLAY |
| | | Identifies Sample by Number | | | GRAVEL | | CLAYEY SAND |
| | | SPLIT-BARREL | | | SILTY CLAY | | |
| | AUGER | | CLAYEY SILT | | | | |
| | ROCK CORE | | | | | | |
| | THIN-WALLED TUBE | | | | | | |
| | CONTINUOUS SAMPLER | | | | | | |
| | NO RECOVERY | | | | | | |

| | |
|--------------------------------------|-----------------------|
| DATE DRILLED 2-3-01 | PAGE 1 of 1 |
| DRILLING METHOD PERCUSSION | |
| DRILLED BY LAYNE | |
| LOGGED BY ED KRISH | |
| EXISTING GRADE ELEVATION (FT. AMSL) | |
| LOCATION OR GRID COORDINATES | |

**KERR-McGEE CORPORATION
HYDROLOGY DEPARTMENT
MONITORING WELL INSTALLATION DIAGRAM**

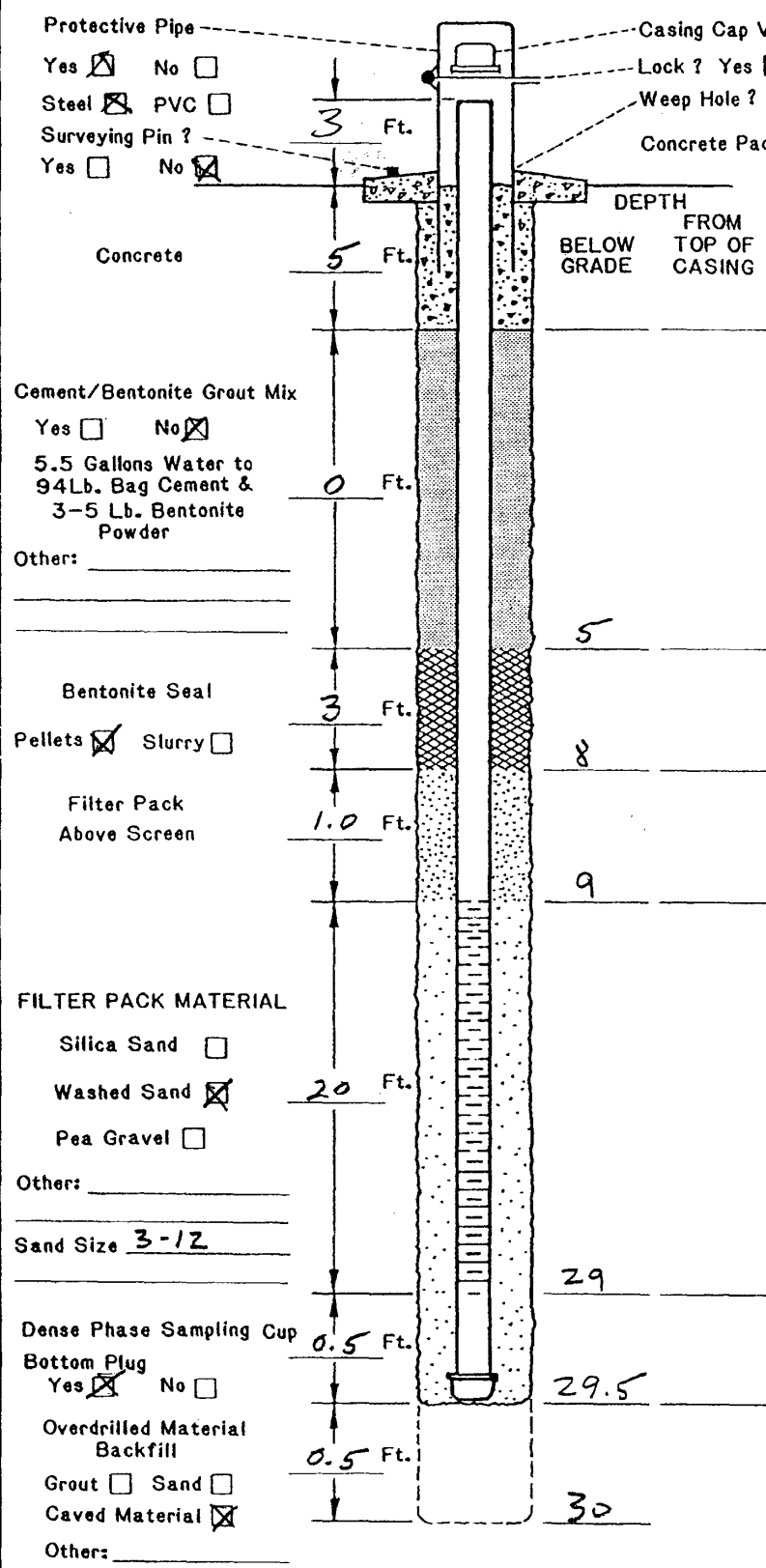

Protective Pipe
 Yes No
 Steel PVC
 Surveying Pin?
 Yes No

Casing Cap Vent? Yes No
 Lock? Yes No
 Weep Hole? Yes No
 Concrete Pad _____ Ft. x _____ Ft. x _____ Inches

Concrete
 5 Ft.
 Cement/Bentonite Grout Mix
 Yes No
 5.5 Gallons Water to
 94Lb. Bag Cement &
 3-5 Lb. Bentonite
 Powder
 Other: _____

Bentonite Seal
 Pellets Slurry
 Filter Pack
 Above Screen
 1.0 Ft.

FILTER PACK MATERIAL
 Silica Sand
 Washed Sand
 Pea Gravel
 Other: _____
 Sand Size 3-12

Dense Phase Sampling Cup
 Bottom Plug
 Yes No
 Overdilled Material
 Backfill
 Grout Sand
 Caved Material
 Other: _____

DEPTH
 FROM
 TOP OF
 CASING

 5

 8

 9

 29

 29.5

 30

DRILLING INFORMATION:

- Borehole Diameter = 9 Inches.
- Were Drilling Additives Used? Yes No
 Revert Bentonite Water
 Solid Auger Hollow Stem Auger
- Was Outer Steel Casing Used? Yes No
 Depth = _____ to _____ Feet.
- Borehole Diameter for Outer Casing _____ Inches.

WELL CONSTRUCTION INFORMATION:

- Type of Casing: PVC Galvanized Teflon
 Stainless Other _____
- Type of Casing Joints: Screw-Couple Glue-Couple Other _____
- Type of Well Screen: PVC Galvanized
 Stainless Teflon Other _____
- Diameter of Casing and Well Screen:
 Casing 2 Inches, Screen 2 Inches.
- Slot Size of Screen: 0.020
- Type of Screen Perforation: Factory Slotted
 Hacksaw Drilled Other _____
- Installed Protector Pipe w/Lock: Yes No

WELL DEVELOPMENT INFORMATION:

- How was Well Developed? Bailing Pumping
 Air Surging (Air or Nitrogen) Other _____
- Time Spent on Well Development?
 _____ / _____ Minutes/Hours
- Approximate Water Volume Removed? _____ Gallons
- Water Clarity Before Development? Clear
 Turbid Opaque
- Water Clarity After Development? Clear
 Turbid Opaque
- Did Water have Odor? Yes No
 If Yes, Describe _____
- Did Water have any Color? Yes No
 If Yes, Describe _____

WATER LEVEL INFORMATION:

Water Level Summary (From Top of Casing)
 During Drilling 17 Ft. Date 2-3-01
 Before Development _____ Ft. Date _____
 After Development _____ Ft. Date _____

Driller/Firm LAYNE Drill Rig Type AP-1000 Date Installed 2-3-01
 Drill Crew Perry Well No. PC-103 Kerr-McGee Hydrologist Ed Krish

SOIL BORING LOG KM-5655-B

| | | | |
|---|--------------------------|---------------------------|-----------------------|
| KERR-McGEE CORPORATION Hydrology Dept. - S&EA Division | KM SUBSIDIARY KMC LLC | LOCATION HENDERSON, NV | BORING NUMBER PC-2 |
|---|--------------------------|---------------------------|-----------------------|

| DEPTH IN FEET | LITHOLOGIC DESCRIPTION | GRAPHIC LOG | UNIFIED SOIL FIELD CLASS. | BLOWS PER 6' | PID (ppm) | SOIL SAMPLE | | | REMARKS OR FIELD OBSERVATIONS | |
|---------------|---|-------------|---------------------------|--------------|-----------|-------------|------|------------|-------------------------------|------|
| | | | | | | NO. | TYPE | DEPTH | | REC. |
| 5 | SAND/SILTY SAND w/ ASD GRAVEL; LT. TAN-BROWN; W/LL - GRAVEL; DRY GRAVEL @ 6-7' | | SM-GM | | | | | | | |
| 10 | SAND AS ABOVE GRAVEL @ 14-15' | | SM-GM | | | | | | | |
| 18' | --- | | Y | | | | | | | |
| 20 | SAND AS ABOVE; SATURATED | | | | | | | | | |
| 25 | | | | | | | | | | |
| 30 | | | | | | | | | | |
| 31 | SILTY CLAY; REDDISH-BROWN GRADING INTO LT. GRAY-GREEN <u>MUDDY CREEK</u> | | CL | 312-27 | | 1 | X | 30 31.5 | 1.4' | |
| 35 | TO 35' | | | | | | | | | |

GROUNDWATER SAMPLE TAKEN @ 30'

| | | | | | |
|-------------|---|---|------------------------------|-------------------------------------|--|
| EXPLANATION | Water Table (24 Hour) | GRAPHIC LOG LEGEND CLAY SILT SAND GRAVEL SILTY CLAY CLAYEY SILT DEBRIS FILL HIGHLY ORGANIC (PEAT) SANDY CLAY CLAYEY SAND | DATE DRILLED 3/23/98 | PAGE 1 of 1 | |
| | Water Table (Time of Boring) | | DRILLING METHOD HSA | DRILLED BY WABER DRILLING | |
| | PID NO. Identifies Sample by Number TYPE Sample Collection Method | SPLIT-BARREL AUGER ROCK CORE THIN-WALLED TUBE CONTINUOUS SAMPLER NO RECOVERY | LOGGED BY T. REED | EXISTING GRADE ELEVATION (FT. AMSL) | |
| | DEPTH RECORD Actual Length of Recovered Sample in Feet | | LOCATION OR GRID COORDINATES | | |

**KERR-McGEE CORPORATION
HYDROLOGY DEPARTMENT
MONITORING WELL INSTALLATION DIAGRAM**

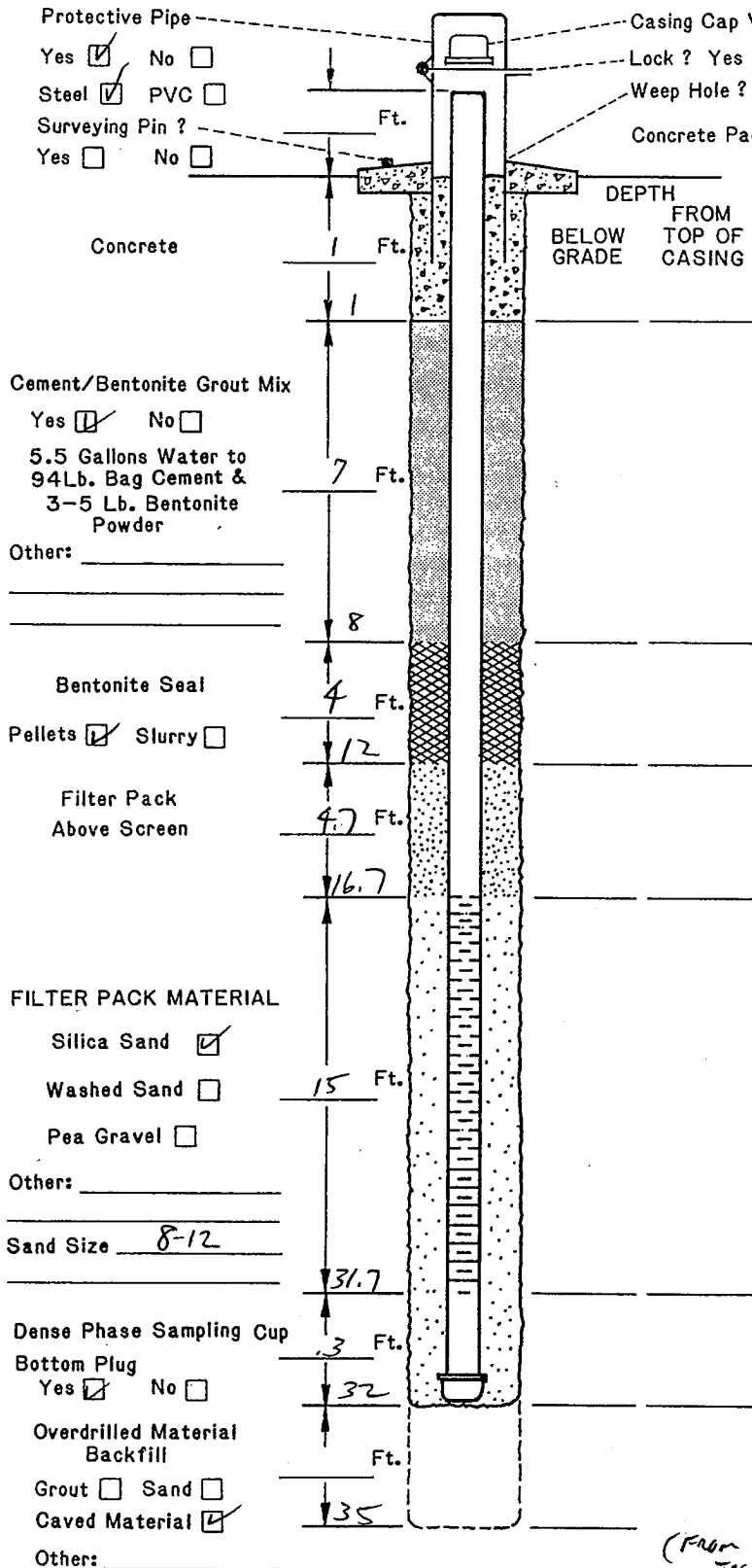

DRILLING INFORMATION:

- Borehole Diameter = 8 Inches.
- Were Drilling Additives Used? Yes No
Revert Bentonite Water
Solid Auger Hollow Stem Auger
- Was Outer Steel Casing Used? Yes No
Depth = _____ to _____ Feet.
- Borehole Diameter for Outer Casing _____ Inches.

WELL CONSTRUCTION INFORMATION:

- Type of Casing: PVC Galvanized Teflon
Stainless Other _____
- Type of Casing Joints: Screw-Couple Glue-Couple Other _____
- Type of Well Screens: PVC Galvanized
Stainless Teflon Other _____
- Diameter of Casing and Well Screens:
Casing 2 Inches, Screen 2 Inches.
- Slot Size of Screen: .020
- Type of Screen Perforations: Factory Slotted
Hacksaw Drilled Other _____
- Installed Protector Pipe w/Lock: Yes No

WELL DEVELOPMENT INFORMATION:

- How was Well Developed? Bailing Pumping
Air Surging (Air or Nitrogen) Other _____
- Time Spent on Well Development?
10 / 1 Minutes/Hours
- Approximate Water Volume Removed? 75 Gallons
- Water Clarity Before Development? Clear
Turbid Opaque
- Water Clarity After Development? Clear
Turbid Opaque
- Did Water have Odor? Yes No
If Yes, Describe _____
- Did Water have any Color? Yes No
If Yes, Describe _____

WATER LEVEL INFORMATION:
Water Level Summary (From Top of Casing)

During Drilling 18' Ft. Date 3/23/98
Before Development _____ Ft. Date _____
After Development 20.01' Ft. Date 3/25/98

Driller/Firm LEE ROBERTSON / WEGEL DRG. Drill Rig Type B-61 Date Installed 3/23/98
Drill Crew L. ROBERTSON / B. JOHNSON Well No. PC-2 Kerr-McGee Hydrologist T. REED

SOIL BORING LOG KM-5655-B

| KERR-McGEE CORPORATION Hydrology Dept. - S&EA Division | | KM SUBSIDIARY KMC-LLC | | LOCATION HENDERSON NV | | | BORING NUMBER PC-52 | | |
|---|---|--------------------------|---------------------------|--------------------------|-----------|-------------|------------------------|-------|--------------------------------------|
| DEPTH IN FEET | LITHOLOGIC DESCRIPTION | GRAPHIC LOG | UNIFIED SOIL FIELD CLASS. | BLOWS PER 6" | PID (ppm) | SOIL SAMPLE | | | REMARKS OR FIELD OBSERVATIONS |
| | | | | | | NO. | TYPE | DEPTH | |
| 5 | SILTY SAND w/ GRAVEL LT TAN - RED BROWN WELL GRADED DRY | SM/Gr | | | | | | | |
| 10 | | | | | | | | | |
| 15 | | | | | | | | | |
| 20 | SAND/GRAVEL DARK BROWN CLAYEY MOIST BEING WET | | | | | | | | GROUND WATER SAMPLE COLLECTED AT 20' |
| 25 | SAND (MS-VCS) DIL BROWN TR GRAVEL | SM | | | | | | | |
| 30 | | | | | | | | | |
| 33 | SILTY CLAY LT GRAY TO OFF WHITE LAM SOFT TO FIRM | CL | | | | | | | 33' T/ MUDDY (REEL) TO 34' |

| | | | | | | | |
|--|--------------------|--|---------------------------|--------|------------------------|------------------------------|-------------------------------------|
| EXPLANATION | ▼ | Water Table (24 Hour) | GRAPHIC LOG LEGEND | | DATE DRILLED 5/4/98 | PAGE 1 of 1 | |
| | ▽ | Water Table (Time of Boring) | | | ▨ | DEBRIS FILL | DRILLING METHOD HSA |
| | PID NO. TYPE | Photoionization Detection (ppm) Identifies Sample by Number Sample Collection Method | ▨ | SILT | ▨ | HIGHLY ORGANIC (PEAT) | DRILLED BY WEBER |
| | ▨ | SPLIT-BARREL | ▨ | SAND | ▨ | SANDY CLAY | LOGGED BY J. Crawford |
| | ▨ | AUGER | ▨ | GRAVEL | ▨ | CLAYEY SAND | EXISTING GRADE ELEVATION (FT. AMSL) |
| ▨ | THIN-WALLED TUBE | ▨ | SILTY CLAY | ▨ | | LOCATION OR GRID COORDINATES | |
| ▨ | CONTINUOUS SAMPLER | ▨ | CLAYEY SILT | ▨ | | | |
| ▨ | ROCK CORE | ▨ | | ▨ | | | |
| ▨ | NO RECOVERY | ▨ | | ▨ | | | |
| DEPTH Depth Top and Bottom of Sample | | | | | | | |
| REC. Actual Length of Recovered Sample in Feet | | | | | | | |

SOIL BORING LOG KM-5655-B

| KERR-McGEE CORPORATION Hydrology Dept. - S&EA Division | | KM SUBSIDIARY KMC-LLC | | LOCATION HENDERSON NV | | BORING NUMBER PC-53 | | | |
|---|---|--------------------------|---------------------------|--------------------------|-----------|------------------------|------|-------|-------------------------------|
| DEPTH IN FEET | LITHOLOGIC DESCRIPTION | GRAPHIC LOG | UNIFIED SOIL FIELD CLASS. | BLOWS PER 6" | PID (ppm) | SOIL SAMPLE | | | REMARKS OR FIELD OBSERVATIONS |
| | | | | | | NO. | TYPE | DEPTH | |
| 5 | SILTY SAND (TO BRN TO TAN GRAVELS WELL GRADED DRY | | | | | | | | |
| 15 | SILTY SAND w/ GRAVEL BENE CLAYEY MOIST DARK BRWN | | | | | | | | |
| 25 | SAND SILTY BRN-DK BRN SL CLAYEY TR GRAVELS CR5-V CR5 GR SAT | | | | | | | | |
| 30 | SILTY CLAY GRN GY TO OFF WH LAM FIRM | | | | | | | | 32' T/ MUDDY REGIL |
| | | | | | | | | | TO 35' |

| | | | | | | |
|--------------------|------------------|---------------------------------|---------------------------|--|------------------------------------|------------------------------|
| EXPLANATION | ▼ | Water Table (24 Hour) | GRAPHIC LOG LEGEND | | DATE DRILLED 5/4/98 | PAGE 1 of 1 |
| | ▽ | Water Table (Time of Boring) | | | | |
| | PID | Photoionization Detection (ppm) | | | DRILLED BY WEBER | |
| | NO. | Identifies Sample by Number | | | LOGGED BY J. GAWFORD | |
| | TYPE | Sample Collection Method | | | EXISTING GRADE ELEVATION (FT AMSL) | |
| | SPLIT-BARREL | | AUGER | | ROCK CORE | LOCATION OR GRID COORDINATES |
| | THIN-WALLED TUBE | | CONTINUOUS SAMPLER | | NO RECOVERY | |

DEPTH Depth Top and Bottom of Sample
 REC. Actual Length of Recovered Sample in Feet

[CASING PROTECTION]
 FLUSH
 MOUNT

KERR-McGEE CORPORATION
 HYDROLOGY DEPARTMENT
 MONITORING WELL INSTALLATION DIAGRAM

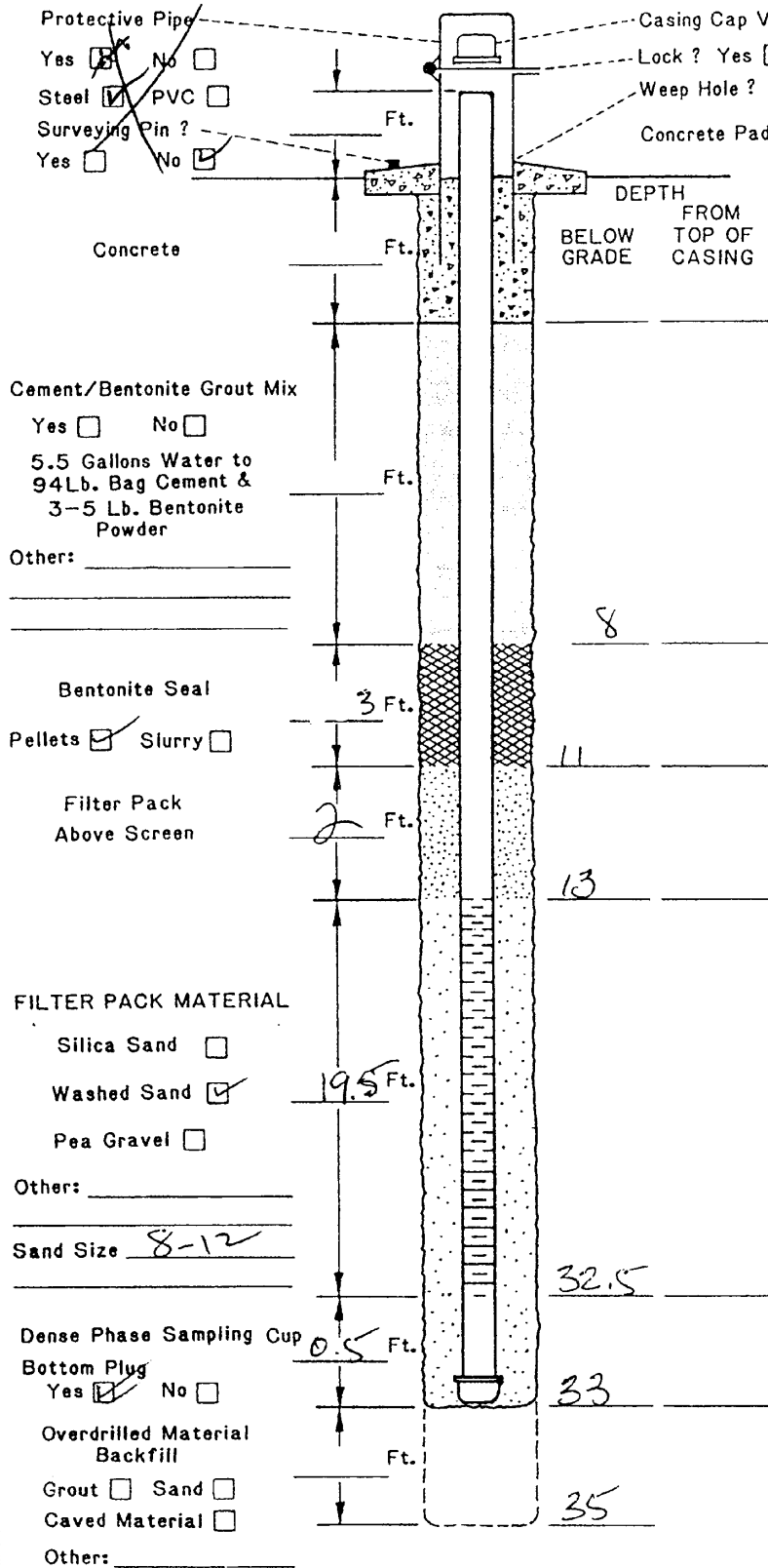

Casing Cap Vent? Yes No
 Lock? Yes No
 Weep Hole? Yes No
 Concrete Pad 1 Ft. x 1 Ft. x 2 Inches

DRILLING INFORMATION:
 1. Borehole Diameter = _____ Inches.
 2. Were Drilling Additives Used? Yes No
 Revert Bentonite Water
 Solid Auger Hollow Stem Auger
 3. Was Outer Steel Casing Used? Yes No
 Depth = _____ to _____ Feet.

WELL CONSTRUCTION INFORMATION:
 1. Type of Casings: PVC Galvanized Teflon
 Stainless Other _____
 2. Type of Casing Joints: Screw-Couple Glue-Couple Other _____
 3. Type of Well Screens: PVC Galvanized
 Stainless Teflon Other _____
 4. Diameter of Casing and Well Screen:
 Casing 2 Inches, Screen 2 Inches.
 5. Slot Size of Screen: .020
 6. Type of Screen Perforation: Factory Slotted
 Hacksaw Drilled Other _____
 7. Installed Protector Pipe w/Lock: Yes No

WELL DEVELOPMENT INFORMATION:
 1. How was Well Developed? Bailing Pumping
 Air Surging (Air or Nitrogen) Other _____
 2. Time Spent on Well Development?
 _____ / _____ Minutes/Hours
 3. Approximate Water Volume Removed? 100 Gallons
 4. Water Clarity Before Development? Clear
 Turbid Opaque
 5. Water Clarity After Development? Clear
 Turbid Opaque
 6. Did Water have Odor? Yes No
 If Yes, Describe _____
 7. Did Water have any Color? Yes No
 If Yes, Describe _____

WATER LEVEL INFORMATION:
 Water Level Summary (From Top of Casing)
 During Drilling _____ Ft. Date _____
 Before Development 18 Ft. Date 5/4/98
 After Development 19.54 Ft. Date 5/12/98

Driller/Firm WEBER Drill Rig Type MOBILE 361 Date Installed 5/4/98
 Drill Crew LEE ROBERTSON Well No. PC-53 Kerr-McGee Hydrologist J. Crawford

SOIL BORING LOG KM-5655-B

| KERR-McGEE CORPORATION Hydrology Dept. - S&EA Division | | KM SUBSIDIARY KMC LLC | | LOCATION HENDERSON NV | | BORING NUMBER PC 98 | | | | |
|---|--|--------------------------|---------------------------|--------------------------|-----------|------------------------|------|-------|------|-------------------------------|
| DEPTH IN FEET | LITHOLOGIC DESCRIPTION | GRAPHIC LOG | UNIFIED SOIL FIELD CLASS. | BLOWS PER 6" | PID (ppm) | SOIL SAMPLE | | | | REMARKS OR FIELD OBSERVATIONS |
| | | | | | | NO. | TYPE | DEPTH | REC. | |
| 5 | 0-12 gravelly SAND, mod yell brn (10YR 5/4), 20-25% granules & sm. pebbles to 1" diam (volc) sp-mod silt in matrix (10-20%). Sand vf-vc, SR-SA | | SP | | | | | | | |
| 16 | 12-16 silty silty GRAVEL H brn (5YR 5/4), 20% silt 25% vf-vc A-SR sand. 50% volc granules to cobbles up to 6" diam Mod com caliche throughout | | GW | | | | | | | damp @ 15' |
| 25 | 16-34 silty gravelly SAND, mod brn (5YR 4/4) 20-25% silt, 20-25% granules and sm pebbles to 3/4". 50% vf-vc A-SR sand | | SW | | | | | | | ▽ @ 22' |
| 37 | 34-37 silty SAND, lt yell brn (10YR 6/4), vf-fg w/ minor mg, SR-SA. 25-30% silt. Mod com m-vc caliche nodules. Very calcareous | | SM GC-ML | | | | | | | |

EXPLANATION

- Water Table (24 Hour)
- Water Table (Time of Boring)
- PID Photoionization Detection (ppm)
- Identifies Sample by Number
- Sample Collection Method
- SPLIT-BARREL
- AUGER
- ROCK CORE
- THIN-WALLED TUBE
- CONTINUOUS SAMPLER
- NO RECOVERY
- DEPTH Depth Top and Bottom of Sample
- REC. Actual Length of Recovered Sample in Feet

GRAPHIC LOG LEGEND

- CLAY
- SILT
- SAND
- GRAVEL
- SILTY CLAY
- CLAYEY SILT
- DEBRIS FILL
- HIGHLY ORGANIC (PEAT)
- SANDY CLAY
- CLAYEY SAND

DATE DRILLED: 5-16-00
PAGE: 1 of 2

DRILLING METHOD: HSA

DRILLED BY: COMPLIANCE

LOGGED BY: ED KRISH

EXISTING GRADE ELEVATION (FT AMSL):

LOCATION OR GRID COORDINATES:

SOIL BORING LOG KM-5655-B

| KERR-McGEE CORPORATION Hydrology Dept. - S&EA Division | | KM SUBSIDIARY KMC LLC | | LOCATION HENDERSON, NV | | | BORING NUMBER PC 98 | | | |
|---|--|---------------------------------|---------------------------|----------------------------------|-----------|-------------|-------------------------------|-------|------|-------------------------------|
| DEPTH IN FEET | LITHOLOGIC DESCRIPTION | GRAPHIC LOG | UNIFIED SOIL FIELD CLASS. | BLOWS PER 6" | PID (ppm) | SOIL SAMPLE | | | | REMARKS OR FIELD OBSERVATIONS |
| | | | | | | NO. | TYPE | DEPTH | REC. | |
| 41 | 37- 41 sdy grav SILT/silty grav SAND w/ 15% dissem granules to 1/8-1/4", mod gry orange pink (5YR 6/2). Contains 25-50% v-f sd in silt/clay matrix. 10-20% vblc + 1s granules to 1/8-1/4". Very calcareous w/ mod c-vc caliche nodules. 41-45 silty CLAY, lt gm gry (5G 8/1) and yell gry (5G 8/1). 25% silt, v. calcareous w/ minor m-vc sized caliche nodules dissem. | CL | | | | | | | | MC @ 41' |
| 45 | | 45' TD | | | | | | | | |

EXPLANATION

| | | |
|-----------------------|------------------------------|--------------|
| Water Table (24 Hour) | Water Table (Time of Boring) | PID NO. TYPE |
| SPLIT-BARREL | AUGER | ROCK CORE |
| THIN-WALLED TUBE | CONTINUOUS SAMPLER | NO RECOVERY |

DEPTH Depth Top and Bottom of Sample
 REC. Actual Length of Recovered Sample in Feet

GRAPHIC LOG LEGEND

| | |
|-------------|-----------------------|
| CLAY | DEBRIS FILL |
| SILT | HIGHLY ORGANIC (PEAT) |
| SAND | SANDY CLAY |
| GRAVEL | CLAYEY SAND |
| SILTY CLAY | |
| CLAYEY SILT | |

DATE DRILLED
5-16-00

PAGE
2 of 2

DRILLING METHOD
HSA

DRILLED BY
COMPLIANCE

LOGGED BY
ED KRISH

EXISTING GRADE ELEVATION (FT AMSL)

LOCATION OR GRID COORDINATES

**KERR-McGEE CORPORATION
HYDROLOGY DEPARTMENT
MONITORING WELL INSTALLATION DIAGRAM**

FLUSH
Mount

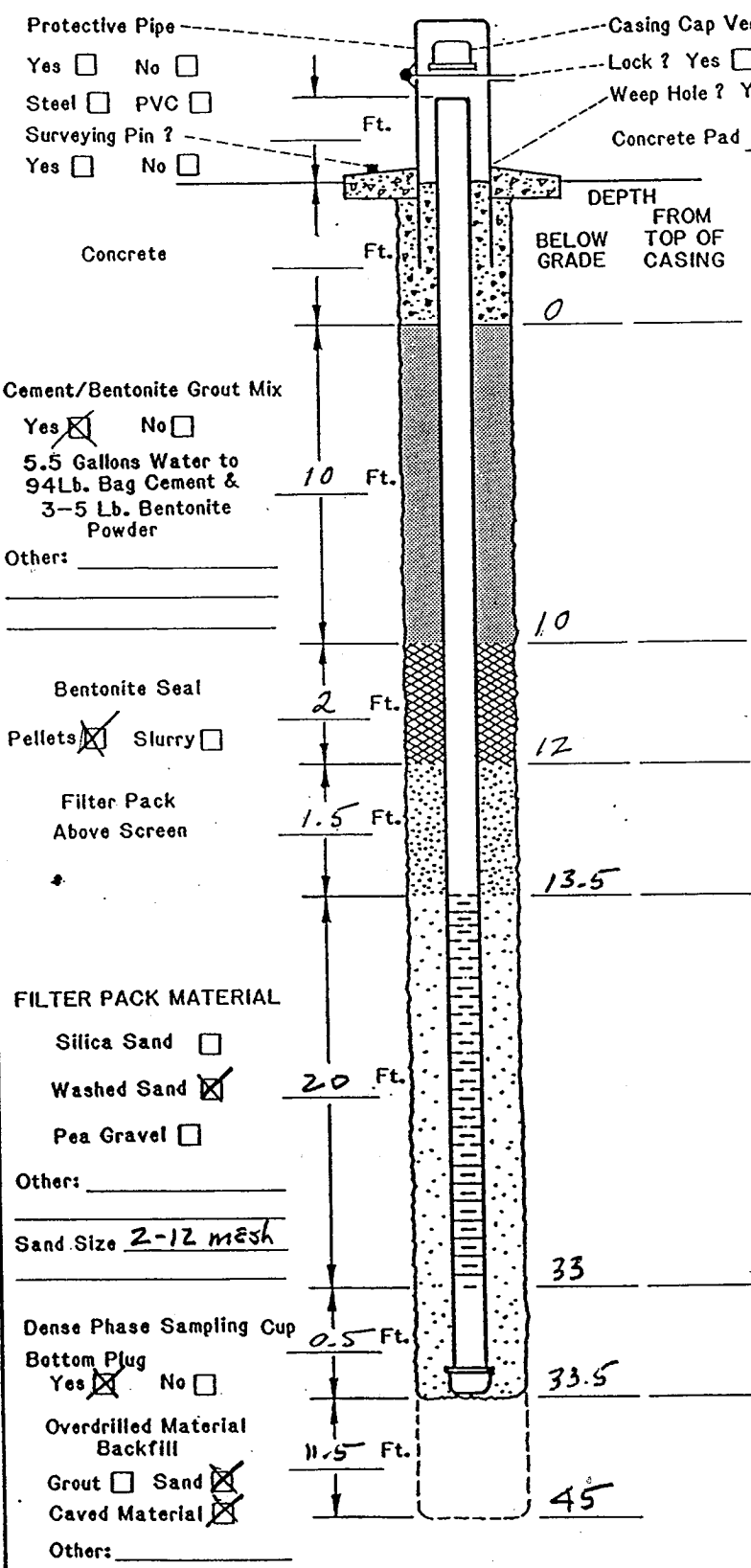

DRILLING INFORMATION:

- Borehole Diameter = 10.5 Inches.
- Were Drilling Additives Used? Yes No
Revert Bentonite Water
Solid Auger Hollow Stem Auger
- Was Outer Steel Casing Used? Yes No
Depth = _____ to _____ Feet.
- Borehole Diameter for Outer Casing _____ Inches.

WELL CONSTRUCTION INFORMATION:

- Type of Casing: PVC Galvanized Teflon
Stainless Other _____
- Type of Casing Joints: Screw-Couple Glue-Couple Other _____
- Type of Well Screens: PVC Galvanized
Stainless Teflon Other _____
- Diameter of Casing and Well Screens:
Casing 4 Inches, Screen 4 Inc
- Slot Size of Screens: _____
- Type of Screen Perforation: Factory Slotted
Hacksaw Drilled Other _____
- Installed Protector Pipe w/Lock: Yes No

WELL DEVELOPMENT INFORMATION:

- How was Well Developed? Bailing Pumping
Air Surging (Air or Nitrogen) Other _____
- Time Spent on Well Development?
1 60 (Minutes) / Hours
- Approximate Water Volume Removed? _____ Gallons
- Water Clarity Before Development? Clear
Turbid Opaque
- Water Clarity After Development? Clear
Turbid Opaque
- Did Water have Odor? Yes No
If Yes, Describe _____
- Did Water have any Color? Yes No
If Yes, Describe _____

WATER LEVEL INFORMATION:

Water Level Summary (From Top of Casing)
During Drilling 22 Ft. Date 5-16-00
Before Development 14.01 Ft. Date 5-17-00
After Development _____ Ft. Date _____

Driller/Firm COMPLIANCE Drill Rig Type Mobil B-59 Date Installed 5-17-00
Drill Crew Loya Well No. PC 98 Kerr-McGee Hydrologist ED KRISH

SOIL BORING LOG KM-5655-B

| KERR-McGEE CORPORATION Hydrology Dept. - S&EA Division | | KM SUBSIDIARY KMCC | | LOCATION Henderson NV | | BORING NUMBER PC 98R | | | |
|---|--|---|---------------------------|---|-----------|---|------|-------|-------------------------------|
| DEPTH IN FEET | LITHOLOGIC DESCRIPTION | GRAPHIC LOG | UNIFIED SOIL FIELD CLASS. | BLOWS PER 6" | PID (ppm) | SOIL SAMPLE | | | REMARKS OR FIELD OBSERVATIONS |
| | | | | | | NO. | TYPE | DEPTH | |
| 5 | 0-5 gravelly SAND gryish brn w/10% silt, 20-30% granules - pea gravel to 3/4". vf-vc SA sd | | SP | | | | | | |
| 9 | 5-9 SAND, gry brn w/10% silt and 5-10% volc granules to 1/4". f-vc SA sand | | SW | | | | | | |
| 12 | 9-10 sdy GRAVEL (to 1") 25-35% vf-vc sd | | SW | | | | | | damp @ 12' |
| 15 | 10-12 SAND, brn, 10% silt, 5% granules. f-vc volc, SA sand | | | | | | | | |
| 20 | 12-24 sdy GRAVEL brn. w/5-10% silt, 25% vf-vc, SA-A sand. Granules to pea gravel, A-SA. 1/2" - 3/4" w/ minor 3/4" - 2" Locally caliche. cemented. | | GW | | | | | | ▽ @ 18' |
| 24 | 16'-20' hard. Com caliche cement | | SP | 29 30 | | | | | |
| 26 | 24-26 SAND. gry brn. SR, clean, f-mg w/c-vcg | | | | | | | | |
| 30 | 26-34 sdy GRAVEL gry brn, 10-15% silt, 25- 30% vf-vc, SA sand in granule - pea gravel to 1/2" - 3/4" | | GW | 22 29 30 | | | | | |
| 34 | 29-30 - cobbles up to 7" 34-40.5 gravelly silty SAND 20-30% silt and 10-15% volc granules to 1/4", brn. Com. dissem sd-size | | GM SM | 12 13 31 | | | | | |
| | | <p>▼ Water Table (24 Hour)</p> <p>▽ Water Table (Time of Boring)</p> <p>PID Photoionization Detection (ppm)</p> <p>NO. Identifies Sample by Number</p> <p>TYPE Sample Collection Method</p> | | <p>GRAPHIC LOG LEGEND</p> <p> CLAY</p> <p> SILT</p> <p> SAND</p> <p> GRAVEL</p> <p> SILTY CLAY</p> <p> CLAYEY SILT</p> <p> DEBRIS FILL</p> <p> HIGHLY ORGANIC (PEAT)</p> <p> SANDY CLAY</p> <p> CLAYEY SAND</p> | | <p>DATE DRILLED 8-8-00</p> <p>PAGE 1 of 2</p> <p>DRILLING METHOD PERCUSSION</p> <p>DRILLED BY LAYNE</p> <p>LOGGED BY ED KRISH</p> <p>EXISTING GRADE ELEVATION (FT AMSL)</p> <p>LOCATION OR GRID COORDINATES</p> | | | |
| <p>EXPLANATION</p> <p> SPLIT-BARREL</p> <p> THIN-WALLED TUBE</p> <p> AUGER</p> <p> CONTINUOUS SAMPLER</p> <p> ROCK CORE</p> <p> NO RECOVERY</p> <p>DEPTH Depth Top and Bottom of Sample</p> <p>REC. Actual Length of Recovered Sample in Feet</p> | | | | | | | | | |

SOIL BORING LOG KM-5655-B

| | | | |
|---|------------------------------|---------------------------------|--------------------------------|
| KERR-McGEE CORPORATION Hydrology Dept. - S&EA Division | KM SUBSIDIARY KMCC | LOCATION HENDERSON NV | BORING NUMBER PC 98R |
|---|------------------------------|---------------------------------|--------------------------------|

| DEPTH IN FEET | LITHOLOGIC DESCRIPTION | GRAPHIC LOG | UNIFIED SOIL FIELD CLASS. | BLOWS PER 6" | PID (ppm) | SOIL SAMPLE | | | | REMARKS OR FIELD OBSERVATIONS |
|---------------|--|-------------|---------------------------|--------------|-----------|-------------|------|-------|------|-------------------------------|
| | | | | | | NO. | TYPE | DEPTH | REC. | |
| 40.5 | caliche nodules. Very calcareous. Sand is vf-f w/minor mg, SA-SR 40.5-41.5 silty CLAY lt grn, w/ dissem sm gypsum x tals TD 41.5' | XV | CL | | | | | | | |

| | | | | | | | |
|--------------------|-------------------------------------|---|-------------------------------------|------------------------------------|--------------------------------------|------------------------------|--|
| EXPLANATION | <input checked="" type="checkbox"/> | Water Table (24 Hour) | GRAPHIC LOG LEGEND | | DATE DRILLED 18-8-00 | PAGE 2 of 2 | |
| | <input checked="" type="checkbox"/> | Water Table (Time of Boring) | CLAY | DEBRIS FILL | DRILLING METHOD PERCUSSION | | |
| | <input checked="" type="checkbox"/> | PID | SILT | HIGHLY ORGANIC (PEAT) | | | |
| | <input checked="" type="checkbox"/> | NO. | <input checked="" type="checkbox"/> | SAND | SANDY CLAY | DRILLED BY LAYNE | |
| | <input checked="" type="checkbox"/> | TYPE | <input checked="" type="checkbox"/> | GRAVEL | CLAYEY SAND | | |
| | SPLIT-BARREL | | AUGER | | ROCK CORE | LOGGED BY ED KRISH | |
| | THIN-WALLED TUBE | | CONTINUOUS SAMPLER | | NO RECOVERY | | |
| DEPTH | | Depth Top and Bottom of Sample | | EXISTING GRADE ELEVATION (FT AMSL) | | LOCATION OR GRID COORDINATES | |
| REC. | | Actual Length of Recovered Sample in Feet | | | | | |

KERR-McGEE CORPORATION
 HYDROLOGY DEPARTMENT
 MONITORING WELL INSTALLATION DIAGRAM

FLUSH
 MOUNT

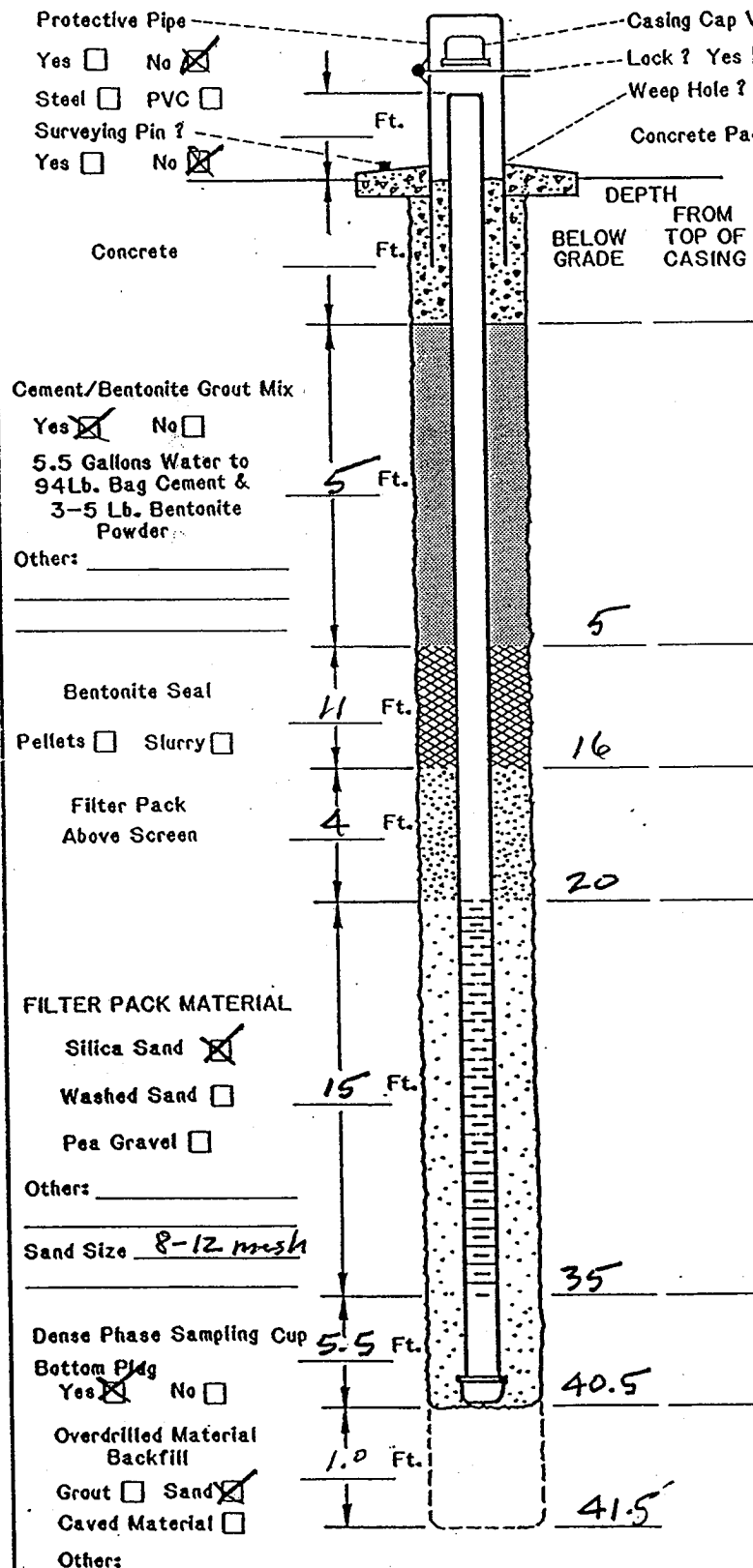

DRILLING INFORMATION:

- Borehole Diameter = 9 Inches.
- Were Drilling Additives Used? Yes No
 Revert Bentonite Water
 Solid Auger Hollow Stem Auger
- Was Outer Steel Casing Used? Yes No
 Depth = _____ to _____ Feet.
- Borehole Diameter for Outer Casing _____ Inches.

WELL CONSTRUCTION INFORMATION:

- Type of Casing: PVC Galvanized Teflon
 Stainless Other _____
- Type of Casing Joints: Screw-Couple Glue-Couple Other _____
- Type of Well Screen: PVC Galvanized
 Stainless Teflon Other _____
- Diameter of Casing and Well Screens:
 Casing 4 Inches, Screen 4 Inches.
- Slot Size of Screens: 0.040
- Type of Screen Perforation: Factory Slotted
 Hacksaw Drilled Other _____
- Installed Protector Pipe w/Locks: Yes No

WELL DEVELOPMENT INFORMATION:

- How was Well Developed? Bailing Pumping
 Air Surging (Air or Nitrogen) Other _____
- Time Spent on Well Development?
120 Minutes/Hours
- Approximate Water Volume Removed? _____ Gallons
- Water Clarity Before Development? Clear
 Turbid Opaque
- Water Clarity After Development? Clear
 Turbid Opaque
- Did Water have Odor? Yes No
 If Yes, Describe faint pesticide
- Did Water have any Color? Yes No
 If Yes, Describe _____

WATER LEVEL INFORMATION:

Water Level Summary (From Top of Casing)
 During Drilling 18 Ft. Date 8-8-00
 Before Development _____ Ft. Date _____
 After Development _____ Ft. Date _____

Driller/Firm _____

Drill Rig Type AP-1000

Date Installed 8-8-00

Drill Crew _____

Well No. PC 98R

Kerr-McGee Hydrologist ED KRISH

| | | | |
|-------------------------------------|-----------------------|--|-----------------|
| Project Number: 2027.11.10 | | Boring ID: PRD-Bench test boring (I 2) | |
| Project Name: Trazox PRD bench test | | Location: Cost/WRF Henderson, NV | |
| Drilling Contractor: Eagle | | Logged By: Patrick Ferringer | |
| Drilling Method: HSA R-51 | Date Started: 12/6/10 | Total Depth: 40' BGS | Depth to Water: |
| Borehole Dia. (in): | Completed: | Surface Elev.: | TOC Elev.: |

Surface Seal Type:
Interval (ft bgs) From: To:

Remarks:
- collect (3) 5 gal. buckets of soil in saturated zone ~ 20'-40'
- collect 10 gal of water w/ bailer from borehole

| Depth (ft) | Sample ID | Sample Time | Recovery % | Blow Count | Graphic Log | USCS Code | Material Description | Water Level | PID (ppm) |
|------------|-----------|-------------|------------|------------|-------------|-----------|--|-------------|-----------|
| 1 | | | | | | SP-SM | Brown (7.5PR 5/4) poorly graded sand w/ silt, trace fine SP-SA gravel, <10% med + coarse sand, 75% v. fine - fine sand, 15% silt, dry and med dense, non plastic, strong HCL rxn. | | |
| 2 | | | | | | | | | |
| 3 | | | | | | | | | |
| 4 | | | | | | | | | |
| 5 | | | | | | | -5': brown (7.5PR 4 1/2), trace fine - med gravel, <15% med - coarse sand, 75% v. fine - fine sand, 10% silt, | | |
| 6 | | | | | | | -7': trace fine gravel | | |
| 7 | | | | | | | | | |
| 8 | | | | | | | | | |
| 9 | | | | | | SP | 9': Brown (7.5PR 4 1/2) poorly graded sand, trace fine gravel SP-SA, ~5% coarse sand, ~20% med sand, ~70% v. fine - fine sand, 5% silt, dry and med dense, strong HCL rxn. non plastic | | |
| 10 | | | | | | | | | |
| 11 | | | | | | | | | |
| 12 | | | | | | | | | |
| 13 | | | | | | | | | |
| 14 | | | | | | | | | |
| 15 | | | | | | | | | |
| 16 | | | | | | | -16.25': ~5% fine gravel | | |
| 17 | | | | | | | | | |
| 18 | | | | | | | -18': 5% fine gravel, 5-10% coarse sand, 20-25% med sand, 60-70% v. fine - fine sand, 5% silt | | |
| 19 | | | | | | | | | |
| 20 | | | | | | | | | |
| 21 | | | | | | | | | |
| 22 | | | | | | | | | |
| 23 | | | | | | | | | |
| 24 | | | | | | | | | |
| 25 | | | | | | | -24.5': moist | | |
| 26 | | | | | | | | | |
| 27 | | | | | | | | | |
| 28 | | | | | | SP-SM | 27': brown (7.5PR 5/3) poorly graded sand w/ silt, ~10% med sand, 70% v. fine - fine sand, 15% silt, <5% clay. w/ + med dense, low plasticity, strong HCL rxn. | | |
| 29 | | | | | | | | | |
| 30 | | | | | | | | | |

Boring Log

Project Number: 2027.11.10 Boring ID: PEB Beach test boring (I-2) 8

Project Name: Trax PEB beach test Location: COM / WRF Henderson, NV

Drilling Contractor: Eagle Logged By: Patrick Ferringer

Remarks:

| Depth (ft) | Sample ID | Sample Time | Recovery % | Blow Count | Graphic Log | USCS Code | Material Description | Water Level | PID (ppm) |
|------------|-----------|-------------|------------|------------|-------------|-----------|-------------------------------------|-------------|-----------|
| 31 | | | | | | | | | |
| 32 | | | | | | | | | |
| 33 | | | | | | | 33'; trace fine - coarse R-A gravel | | |
| 34 | | | | | | | | | |
| 35 | | | | | | | | | |
| 36 | | | | | | | | | |
| 37 | | | | | | | | | |
| 38 | | | | | | | | | |
| 39 | | | | | | | | | |
| 40 | | | | | | | | | |
| 41 | | | | | | | | | |
| 42 | | | | | | | | | |
| 43 | | | | | | | | | |
| 44 | | | | | | | | | |
| 45 | | | | | | | | | |
| 46 | | | | | | | | | |
| 47 | | | | | | | | | |
| 48 | | | | | | | | | |
| 49 | | | | | | | | | |
| 50 | | | | | | | | | |
| 51 | | | | | | | | | |
| 52 | | | | | | | | | |
| 53 | | | | | | | | | |
| 54 | | | | | | | | | |
| 55 | | | | | | | | | |
| 56 | | | | | | | | | |
| 57 | | | | | | | | | |
| 58 | | | | | | | | | |
| 59 | | | | | | | | | |
| 60 | | | | | | | | | |
| 61 | | | | | | | | | |
| 62 | | | | | | | | | |
| 63 | | | | | | | | | |
| 64 | | | | | | | | | |
| 65 | | | | | | | | | |

TD @ 40' BGS

SOIL BORING LOG KM-5655-B

| | | | |
|--|---------------------------------|---------------------------------|-------------------------------|
| KERR-McGEE CORPORATION Hydrology Dept. - S&EA Division | KM SUBSIDIARY KMC-LLC | LOCATION HENDERSON NV | BORING NUMBER PC-18 |
|--|---------------------------------|---------------------------------|-------------------------------|

| DEPTH IN FEET | LITHOLOGIC DESCRIPTION | GRAPHIC LOG | UNIFIED SOIL FIELD CLASS. | BLOWS PER 6" | PID (ppm) | SOIL SAMPLE | | | REMARKS OR FIELD OBSERVATIONS |
|---------------|--|-------------|---------------------------|--------------|-----------|-------------|------|-------|-----------------------------------|
| | | | | | | NO. | TYPE | DEPTH | |
| 5 | SILTY SAND RD BRN DRY WELL GRADED GRAVELS | SM | | | | | | | |
| 10 | | | | | | | | | |
| 15 | | | | | | | | | |
| 20 | | | | | | | | | COLLECT GROUNDWATER SAMPLE AT 22' |
| 25 | SAND/GRAVEL BRN HUMID MOIST WELL GRADED | GM | | | | | | | |
| 30 | SAND/GRAVEL GRAYISH BRWN WELL GRADED SAT SILTY | GM | | | | | | | |

| | | | | | | | |
|--------------------|--------------------|--|---------------------------|-------------|-------------------------------|---------------------------------|-------------------------------------|
| EXPLANATION | ▼ | Water Table (24 Hour) | GRAPHIC LOG LEGEND | | DATE DRILLED 4/2/98 | PAGE 1 of 2 | |
| | ▽ | Water Table (Time of Boring) | ▨ | CLAY | ▩ | DEBRIS FILL | |
| | PID NO. TYPE | Photoionization Detection (ppm) Identifies Sample by Number Sample Collection Method | ▧ | SILT | ▨ | HIGHLY ORGANIC (PEAT) | |
| | ⊗ | SPLIT-BARREL | ▩ | AUGER | ▨ | SANDY CLAY | DRILLING METHOD HSA |
| ▩ | THIN-WALLED TUBE | ▨ | ROCK CORE | ▨ | CLAYEY SAND | DRILLED BY WEDER | |
| ▩ | CONTINUOUS SAMPLER | ▨ | NO RECOVERY | ▨ | CLAYEY SAND | LOGGED BY J. Crawford | |
| — | DEPTH | Depth Top and Bottom of Sample | ▨ | SAND | ▨ | CLAYEY SAND | EXISTING GRADE ELEVATION (FT. AMSL) |
| — | REC. | Actual Length of Recovered Sample in Feet | ▨ | GRAVEL | ▨ | CLAYEY SAND | LOCATION OR GRID COORDINATES |
| — | | | ▨ | SANDY CLAY | ▨ | CLAYEY SAND | |
| — | | | ▨ | SILT CLAY | ▨ | CLAYEY SAND | |
| — | | | ▨ | CLAYEY SILT | ▨ | CLAYEY SAND | |

SOIL BORING LOG KM-5655-B

| KERR-McGEE CORPORATION Hydrology Dept. - S&EA Division | | KM SUBSIDIARY KMC-LLC | | LOCATION HENDERSON NJ | | BORING NUMBER PC-18 | | | | |
|---|---|--------------------------|---------------------------|--------------------------|-----------|------------------------|-------------------------------------|-------|------|-------------------------------|
| DEPTH IN FEET | LITHOLOGIC DESCRIPTION | GRAPHIC LOG | UNIFIED SOIL FIELD CLASS. | BLOWS PER 6" | PID (ppm) | SOIL SAMPLE | | | | REMARKS OR FIELD OBSERVATIONS |
| | | | | | | NO. | TYPE | DEPTH | REC. | |
| 51 | Sand/Gravel BRN WELL GRADED | | GM | | | | <input checked="" type="checkbox"/> | | | SPLIT SPOON AT 42' |
| 50 | SAND BRN F-CRS GR SM 1/4" GRAVEL WELL GRADED SAT LOOSE SILT SILTY | | SW CL | | | | <input checked="" type="checkbox"/> | | | T/MUDDY CREEK 52' |
| T/MC | SILTY CLAY RD BRN W/ SM FINE SAND & SMALL GRAVELS | | | | | | <input checked="" type="checkbox"/> | | | |
| | SILTY CLAY GREENISH GRAY W/ TAN TO BROWN VARIG. BLOCKY | | | | | | <input checked="" type="checkbox"/> | | | DRILL TO 53' |

| | | | | |
|-------------|--|---|--|------------------------------|
| EXPLANATION | Water Table (24 Hour) | GRAPHIC LOG LEGEND | DATE DRILLED 4/2/98 | PAGE 2 of 2 |
| | Water Table (Time of Boring) | | CLAY SILT SAND GRAVEL SILTY CLAY CLAYEY SILT DEBRIS FILL HIGHLY ORGANIC (PEAT) SANDY CLAY CLAYEY SAND | DRILLING METHOD HSA |
| | PID NO. TYPE Photoionization Detection (ppm) Identifies Sample by Number Sample Collection Method | THIN-WALLED TUBE AUGER CONTINUOUS SAMPLER ROCK CORE NO RECOVERY | | DRILLED BY WEISER |
| | DEPTH REC. | Depth Top and Bottom of Sample Actual Length of Recovered Sample in Feet | EXISTING GRADE ELEVATION (FT. AMSL) | LOCATION OR GRID COORDINATES |

FLUSH
MAIN

KERR-McGEE CORPORATION HYDROLOGY DEPARTMENT MONITORING WELL INSTALLATION DIAGRAM

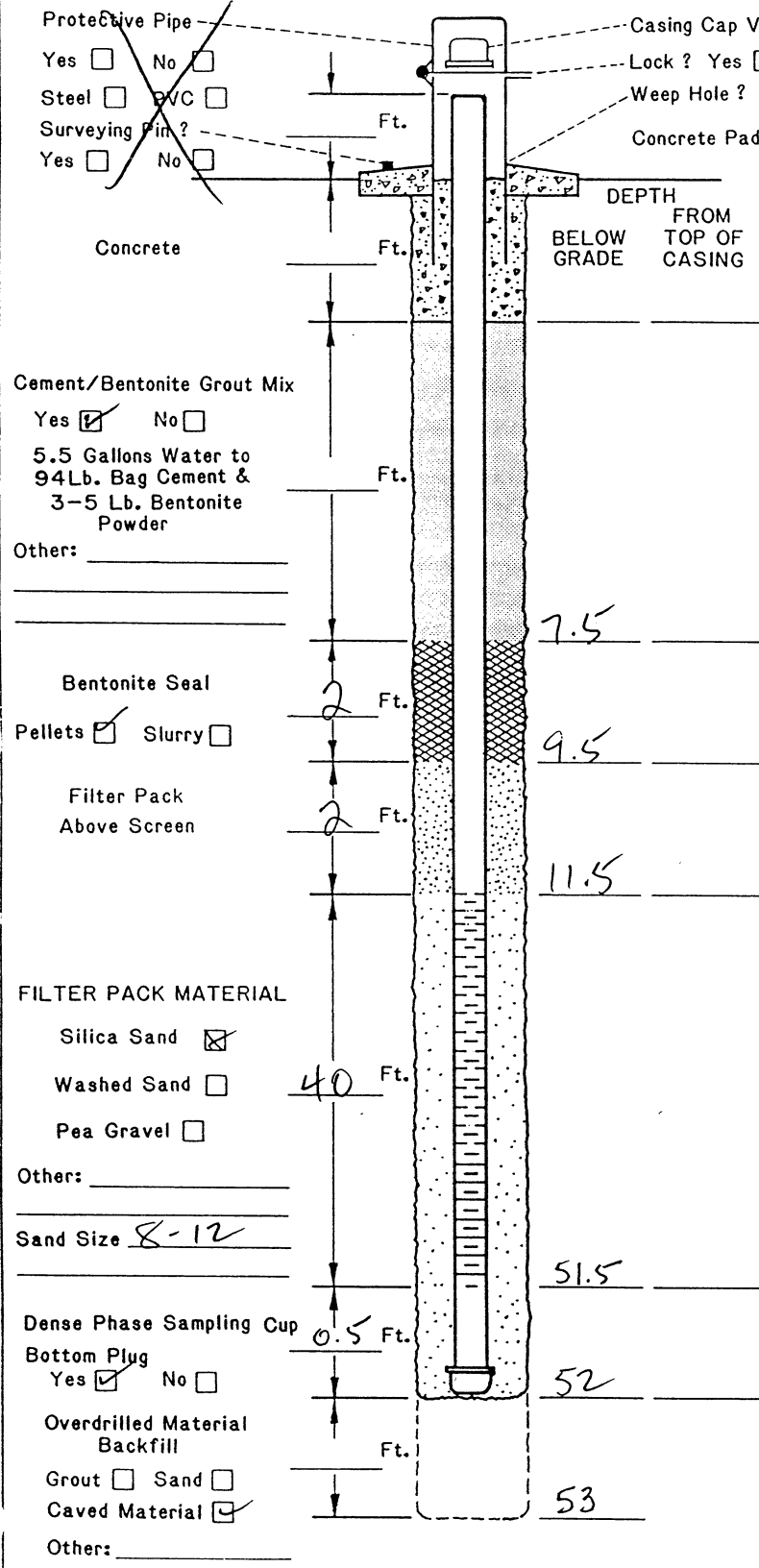

Casing Cap Vent? Yes No
 Lock? Yes No
 Weep Hole? Yes No
 Concrete Pad _____ Ft. x _____ Ft. x _____ Inches

DRILLING INFORMATION:

- Borehole Diameter = 8 Inches.
- Were Drilling Additives Used? Yes No
 Revert Bentonite Water
 Solid Auger Hollow Stem Auger
- Was Outer Steel Casing Used? Yes No
 Depth = _____ to _____ Feet.
- Borehole Diameter for Outer Casing _____ Inches.

WELL CONSTRUCTION INFORMATION:

- Type of Casing: PVC Galvanized Teflon
 Stainless Other _____
- Type of Casing Joints: Screw-Couple Glue-Couple Other _____
- Type of Well Screen: PVC Galvanized
 Stainless Teflon Other _____
- Diameter of Casing and Well Screen:
 Casing 2 Inches, Screen 2 Inches.
- Slot Size of Screens: 10
- Type of Screen Perforation: Factory Slotted
 Hacksaw Drilled Other _____
- Installed Protector Pipe w/Lock: Yes No

WELL DEVELOPMENT INFORMATION:

- How was Well Developed? Bailing Pumping
 Air Surging (Air or Nitrogen) Other _____
- Time Spent on Well Development?
 _____ / _____ Minutes/Hours
- Approximate Water Volume Removed? 110 Gallons
- Water Clarity Before Development? Clear
 Turbid Opaque
- Water Clarity After Development? Clear
 Turbid Opaque
- Did Water have Odor? Yes No
 If Yes, Describe _____
- Did Water have any Color? Yes No
 If Yes, Describe _____

WATER LEVEL INFORMATION:

Water Level Summary (From Top of Casing)
 During Drilling 22 Ft. Date 4/8/98
 Before Development 19.80' Ft. Date 4/17/98
 After Development 19.90' Ft. Date 4/17/98

Driller/Firm WEBER Drill Rig Type MOBILE B-61 XD Date Installed 4/8/98
 Drill Crew LEE ROBERTSON Well No. PC-18 Kerr-McGee Hydrologist J. Crawford

SOIL BORING LOG KM-5655-B

| KERR-McGEE CORPORATION Hydrology Dept. - S&EA Division | | KM SUBSIDIARY KMCLLC | | LOCATION HENDERSON, NV | | BORING NUMBER PC-58 | | | |
|--|---|--------------------------------|---------------------------|----------------------------------|-----------|-------------------------------|------|-------|-------------------------------|
| DEPTH IN FEET | LITHOLOGIC DESCRIPTION | GRAPHIC LOG | UNIFIED SOIL FIELD CLASS. | BLOWS PER 6" | PID (ppm) | SOIL SAMPLE | | | REMARKS OR FIELD OBSERVATIONS |
| | | | | | | NO. | TYPE | DEPTH | |
| 2.5 | BERM : SAND W/ GRAVEL | | | | | | | | |
| 5 | SAND W/ SILT; MED. BROWN; SLI. MOIST; OCC. GRAVEL | | SM | | | | | | |
| 10 | GRAVEL ZONE @ 10-14' | | GM | | | | | | |
| 13 | | | | | | | | | |
| 15 | | | SM | | | | | | |
| 20 | | | SM | | | | | | |
| 25 | GRAVEL ZONE @ 26-28' | | GM | | | | | | |
| 30 | | | SM | | | | | | |
| 34 | SILT CLAY - CLAYEY SILT; GREENISH-WHITE | | CL-ML | | | | | | |
| 35 | U. SLI. PLASTIC; MOOBY CREEK | | CL-ML | | | 1 | X | 35 | 1.5' |
| 36 | TD 36' | | | | | | | 36.5 | |

EXPLANATION

- Water Table (24 Hour)
- Water Table (Time of Boring)
- PID Photoionization Detection (ppm)
- Identifies Sample by Number
- Sample Collection Method
- SPLIT-BARREL
- AUGER
- ROCK CORE
- THIN-WALLED TUBE
- CONTINUOUS SAMPLER
- NO RECOVERY

DEPTH Depth Top and Bottom of Sample
 REC. Actual Length of Recovered Sample in Feet

GRAPHIC LOG LEGEND

- CLAY
- SILT
- SAND
- GRAVEL
- SILTY CLAY
- CLAYEY SILT
- DEBRIS FILL
- HIGHLY ORGANIC (PEAT)
- SANDY CLAY
- CLAYEY SAND

DATE DRILLED: 5/21/98
 PAGE: 1 of 1

DRILLING METHOD: HSA

DRILLED BY: WEBER DRG.

LOGGED BY: T. REED

EXISTING GRADE ELEVATION (FT. AMSL):

LOCATION OR GRID COORDINATES: ~ 500' EAST OF PC-56

**KERR-McGEE CORPORATION
HYDROLOGY DEPARTMENT
MONITORING WELL INSTALLATION DIAGRAM**

FLASH MOUNT

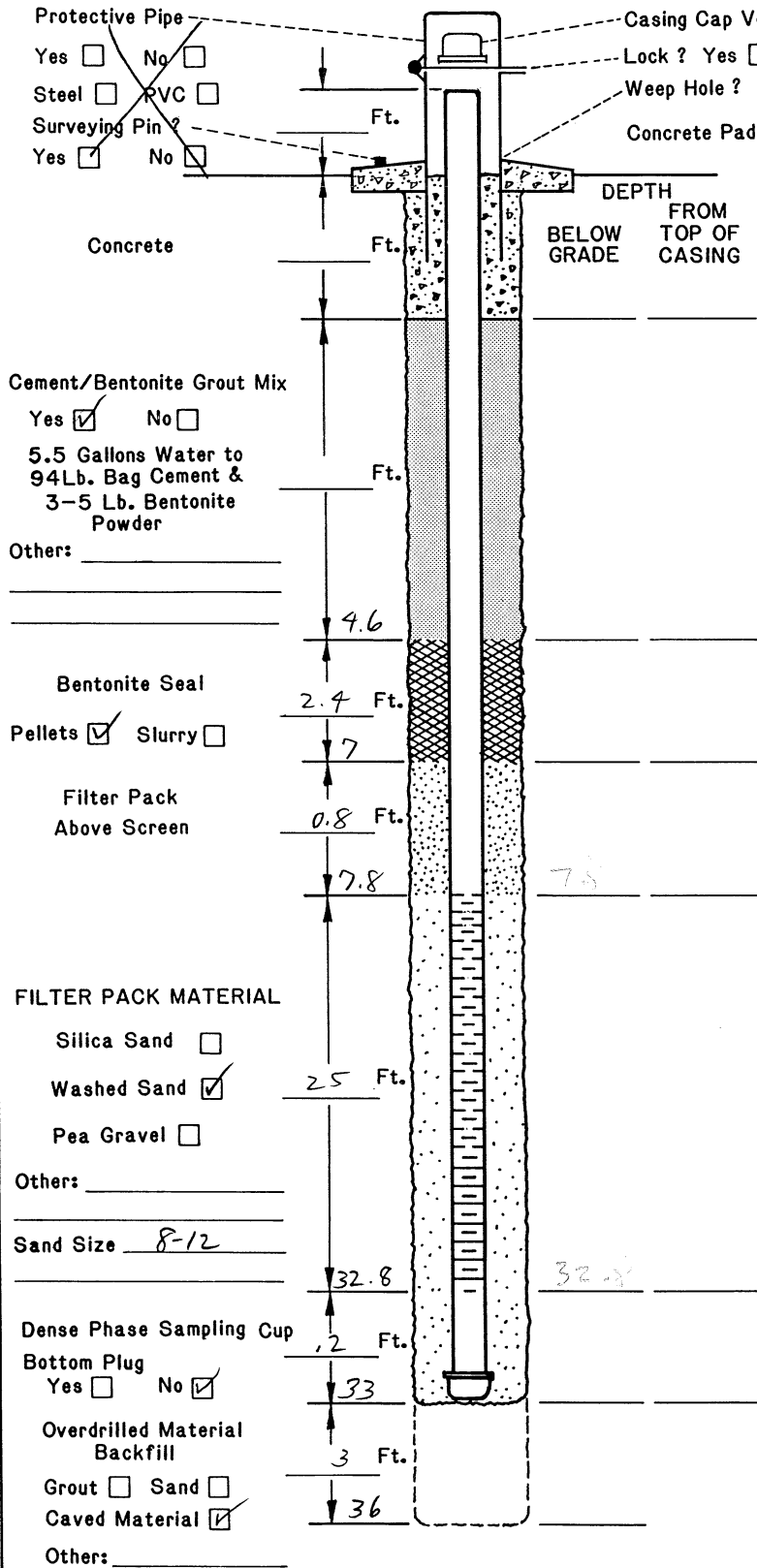

Casing Cap Vent? Yes No
 Lock? Yes No
 Weep Hole? Yes No
 Concrete Pad _____ Ft. x _____ Ft. x _____ Inches

DRILLING INFORMATION:

- Borehole Diameter= 8 Inches.
- Were Drilling Additives Used? Yes No
 Revert Bentonite Water
 Solid Auger Hollow Stem Auger
- Was Outer Steel Casing Used? Yes No
 Depth= _____ to _____ Feet.
- Borehole Diameter for Outer Casing _____ Inches.

WELL CONSTRUCTION INFORMATION:

- Type of Casing: PVC Galvanized Teflon
 Stainless Other _____
- Type of Casing Joints: Screw-Couple Glue-Couple Other _____
- Type of Well Screens: PVC Galvanized
 Stainless Teflon Other _____
- Diameter of Casing and Well Screens:
 Casing 2 Inches, Screen 2 Inches.
- Slot Size of Screens: .020
- Type of Screen Perforations: Factory Slotted
 Hacksaw Drilled Other _____
- Installed Protector Pipe w/Lock: Yes No

WELL DEVELOPMENT INFORMATION:

- How was Well Developed? Bailing Pumping
 Air Surging (Air or Nitrogen) Other _____
- Time Spent on Well Development?
45 10 Minutes/Hours
- Approximate Water Volume Removed? 80 Gallons
- Water Clarity Before Development? Clear
 Turbid Opaque
- Water Clarity After Development? Clear
 Turbid Opaque
- Did Water have Odor? Yes No
 If Yes, Describe _____
- Did Water have any Color? Yes No
 If Yes, Describe _____

WATER LEVEL INFORMATION:
 Water Level Summary (From Top of Casing)

During Drilling 13 Ft. Date 5/21/98
 Before Development _____ Ft. Date _____
 After Development 8.00 Ft. Date 6/15/98

Driller/Firm ROBERTSON / WEBER ORL. Drill Rig Type B-61 HDX Date Installed 5/21/98
 Drill Crew L. ROBERTSON / M. ROBERTSON Well No. PC-58 Kerr-McGee Hydrologist T. REED

SOIL BORING LOG KM-5655-B

| | | | |
|--|--------------------------------|---------------------------------|-------------------------------|
| KERR-McGEE CORPORATION Hydrology Dept. - S&EA Division | KM SUBSIDIARY <i>KMCLLC</i> | LOCATION <i>HENDERSON, N</i> | BORING NUMBER <i>PC-59</i> |
|--|--------------------------------|---------------------------------|-------------------------------|

| DEPTH IN FEET | LITHOLOGIC DESCRIPTION | GRAPHIC LOG | UNIFIED SOIL FIELD CLASS. | BLOWS PER 6" | PID (ppm) | SOIL SAMPLE | | | | REMARKS OR FIELD OBSERVATIONS |
|---------------|---|-------------|---------------------------|--------------|-----------|-------------|-------------------------------------|--------------------|-------------|-------------------------------|
| | | | | | | NO. | TYPE | DEPTH | REC. | |
| 2 | <i>BERM: SAND W/ GRAVEL</i> | | | | | | | | | |
| 5 | <i>SAND W/ SILT; OCC. GRAVEL; MED. BROWN; WELL-GRADED; SLI. MOIST GRAVEL @ 3-4'</i> | | <i>SM</i> | | | | | | | |
| 10 | | | | | | | | | | |
| 15 | | | | | | | | | | |
| 20 | <i>SAND AS ABOVE; SATURATED; OCC. GRAVEL</i> | | <i>SM</i> | | | | | | | |
| 25 | | | | | | | | | | |
| 30 | <i>SANDY SILT; LT. BEIGE; SATURATED; OCC. FINE-MED. SAND</i> | | <i>ML</i> | | | | | | | |
| 34 | | | | | | | | | | |
| 35 | <i>SILTY CLAY; CLAYEY-SILT; MED. GREEN-BEIGE; V. SLI. PLASTIC MUDDY CRACK</i> | | <i>CL-ML</i> | | | | | | | |
| 38 | <i>TD 38'</i> | | | | | <i>1</i> | <input checked="" type="checkbox"/> | <i>38 39.5</i> | <i>1.4'</i> | |

| | | | | |
|--|---|---------------------------|---|----------------------------------|
| EXPLANATION | Water Table (24 Hour) | GRAPHIC LOG LEGEND | DATE DRILLED <i>5/22/93</i> | PAGE <i>1 of 1</i> |
| | Water Table (Time of Boring) | | DRILLING METHOD <i>HSA</i> | |
| | PID NO. Identifies Sample by Number TYPE Sample Collection Method | CLAY | DEBRIS FILL | DRILLED BY <i>WEBER DRUG.</i> |
| | SPLIT-BARREL | SILT | HIGHLY ORGANIC (PEAT) | LOGGED BY <i>T. REED</i> |
| AUGER | SAND | SANDY CLAY | EXISTING GRADE ELEVATION (FT. AMSL) | |
| ROCK CORE | GRAVEL | CLAYEY SAND | LOCATION OR GRID COORDINATES <i>~ 500' WEST OF PC-56</i> | |
| THIN-WALLED TUBE | SILTY CLAY | CLAYEY SILT | | |
| CONTINUOUS SAMPLER | NO RECOVERY | | | |
| DEPTH Depth Top and Bottom of Sample REC. Actual Length of Recovered Sample in Feet | | | | |

FLUSH MOUNT

KERR-McGEE CORPORATION HYDROLOGY DEPARTMENT MONITORING WELL INSTALLATION DIAGRAM

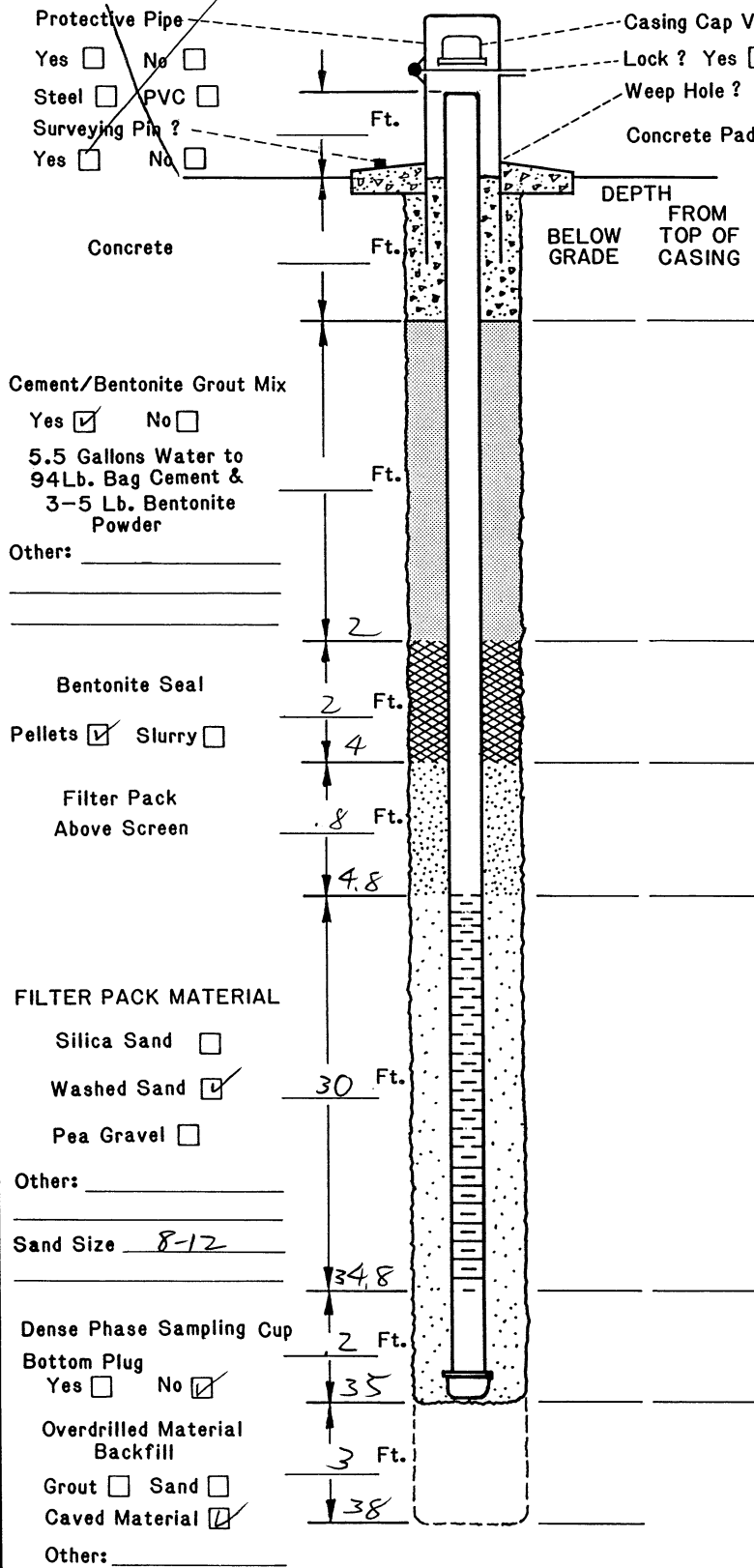

Casing Cap Vent? Yes No
Lock? Yes No
Weep Hole? Yes No

DRILLING INFORMATION:

1. Borehole Diameter= 8 Inches.
2. Were Drilling Additives Used? Yes No
Revert Bentonite Water
Solid Auger Hollow Stem Auger
3. Was Outer Steel Casing Used? Yes No
Depth= _____ to _____ Feet.
4. Borehole Diameter for Outer Casing _____ Inches.

WELL CONSTRUCTION INFORMATION:

1. Type of Casing: PVC Galvanized Teflon
Stainless Other _____
2. Type of Casing Joints: Screw-Couple Glue-Couple Other _____
3. Type of Well Screen: PVC Galvanized
Stainless Teflon Other _____
4. Diameter of Casing and Well Screens:
Casing 2 Inches, Screen 2 Inches.
5. Slot Size of Screens: .020
6. Type of Screen Perforations: Factory Slotted
Hacksaw Drilled Other _____
7. Installed Protector Pipe w/Lock: Yes No

WELL DEVELOPMENT INFORMATION:

1. How was Well Developed? Bailing Pumping
Air Surging (Air or Nitrogen) Other _____
2. Time Spent on Well Development?
15 / 1 Minutes/Hours
3. Approximate Water Volume Removed? 110 Gallons
4. Water Clarity Before Development? Clear
Turbid Opaque
5. Water Clarity After Development? Clear
Turbid Opaque
6. Did Water have Odr? Yes No
If Yes, Describe _____
7. Did Water have any Color? Yes No
If Yes, Describe _____

WATER LEVEL INFORMATION:
Water Level Summary (From Top of Casing)
During Drilling 8 Ft. Date 5/22/98
Before Development _____ Ft. Date _____
After Development 9.14' Ft. Date 6/15/98

Driller/Firm ROBERTSON/WESSER DRG. Drill Rig Type B-61 HDX Date Installed 5/22/98
Drill Crew _____ Well No. PC-59 Kerr-McGee Hydrologist T. REED

SOIL BORING LOG KM-5655-B

| KERR-McGEE CORPORATION Hydrology Dept. - S&EA Division | | KM SUBSIDIARY KMC LLC | | LOCATION Henderson NV | | BORING NUMBER PC 74 | | | | |
|--|--|---------------------------------|---------------------------|---------------------------------|-----------|-------------------------------|------|-------|------|---|
| DEPTH IN FEET | LITHOLOGIC DESCRIPTION | GRAPHIC LOG | UNIFIED SOIL FIELD CLASS. | BLOWS PER 6" | PID (ppm) | SOIL SAMPLE | | | | REMARKS OR FIELD OBSERVATIONS |
| | | | | | | NO. | TYPE | DEPTH | REC. | |
| 5 | 0-8 GRAVEL w/ silty sd, yell orange. 30% gravel + boulders to 2' diam. volcanics 60% vc-vf SA sd 10% silt | | GW | | | | | | | |
| 10 | 8-15 silty SAND w/minor gravel. Inc in silt to 25%. gry brn. sd is vf-vc, SA-A. Gravel up to 2" | | SM | | | | | | | damp @ 7' @ 12.45' ▼ 4-29-00 |
| 15 | 15-21 silty GRAVEL w/minor silt. gry brn volc grav. to 2" w/ sd vc-f SA-A matrix. 10-15% silt | | GW-GM | | | | | | | ▼ WTR @ 16' (Perched) 4-26-00 |
| 20 | 21-24 cly SAND, gry grn, sd f-vc w/ com (40%) clay | | SC | | | | | | | only damp @ 21' ▼ WTR @ 24' 4-26-00 |
| 25 | 24-51 Pea Gravel w/ vc-f sd matrix. gry. st. silty 25% sd 70% pea gravel 27-28.5 w/ com cobbles/ boulders | | GW | | | | | | | |
| 30 | 37-48 boulder zones (thin) scattered throughout | | | | | | | | | |
| 35 | | | | | | | | | | |

| | | | | | | |
|--------------------|------------------|---|---------------------------|-------------------------------------|--------------|-----------------------|
| EXPLANATION | ▼ | Water Table (24 Hour) | GRAPHIC LOG LEGEND | | DATE DRILLED | PAGE |
| | ▽ | Water Table (Time of Boring) | | CLAY | | DEBRIS FILL |
| | PID | Photoionization Detection (ppm) | | SILT | | HIGHLY ORGANIC (PEAT) |
| | NO. | Identifies Sample by Number | | SAND | | SANDY CLAY |
| | TYPE | Sample Collection Method | | GRAVEL | | CLAYEY SAND |
| | SPLIT-BARREL | | AUGER | | ROCK CORE | |
| | THIN-WALLED TUBE | | CONTINUOUS SAMPLER | | NO RECOVERY | |
| DEPTH | | Depth Top and Bottom of Sample | | | | |
| REC. | | Actual Length of Recovered Sample in Feet | | | | |
| | | | | 4-26-00 | | 1 of 2 |
| | | | | DRILLING METHOD | | |
| | | | | HSA | | |
| | | | | DRILLED BY | | |
| | | | | Compliance | | |
| | | | | LOGGED BY | | |
| | | | | E KRISHA | | |
| | | | | EXISTING GRADE ELEVATION (FT. AMSL) | | |
| | | | | LOCATION OR GRID COORDINATES | | |

SOIL BORING LOG KM-5655-B

| KERR-McGEE CORPORATION Hydrology Dept. - S&EA Division | | KM SUBSIDIARY KMC LLC | | LOCATION Henderson NV | | BORING NUMBER PC 74 | | | | |
|---|---|--------------------------|---------------------------|--------------------------|-----------|------------------------|------|-------|------|--|
| DEPTH IN FEET | LITHOLOGIC DESCRIPTION | GRAPHIC LOG | UNIFIED SOIL FIELD CLASS. | BLOWS PER 6" | PID (ppm) | SOIL SAMPLE | | | | REMARKS OR FIELD OBSERVATIONS |
| | | | | | | NO. | TYPE | DEPTH | REC. | |
| 45 | | | GW | | | | | | | SCREENED 40'-50' |
| 51 | 51-56 SAND, m-vc, SA-SR, grn gry, hard. Sl. silty (10%) w/ 10% granules | | SW | | | | | | | WTR S MPL 4-28-00 PH 7.3 TDS 7100 |
| 56 | 56-70 silty sdy CLAY, grn gry & red brn, mottled. Calcareous, sticky, drills slow. w/ 5-15% vf-ma sand in matrix. Contains 10% c-vc-gran sized caliche nodules dissem. throughout | | CL-ML | | | | | | | Muddy Creek @ 56' |
| 70 | TD 70' | | | | | | | | | |

| | | | | | |
|--|-------------------------------------|---------------------------|-----------------------|------------------------------------|------------|
| EXPLANATION | Water Table (24 Hour) | GRAPHIC LOG LEGEND | | DATE DRILLED | PAGE |
| | Water Table (Time of Boring) | CLAY | DEBRIS FILL | 4-26-00 | Z of Z |
| | PID Photoionization Detection (ppm) | SILT | HIGHLY ORGANIC (PEAT) | DRILLING METHOD | HSA |
| | NO. Identifies Sample by Number | SAND | SANDY CLAY | DRILLED BY | Compliance |
| | TYPE Sample Collection Method | GRAVEL | CLAYEY SAND | LOGGED BY | E KRISH |
| | SPLIT-BARREL | AUGER | SILTY CLAY | EXISTING GRADE ELEVATION (FT AMSL) | |
| | THIN-WALLED TUBE | CONTINUOUS SAMPLER | CLAYEY SILT | LOCATION OR GRID COORDINATES | |
| | ROCK CORE | NO RECOVERY | | | |
| DEPTH Depth Top and Bottom of Sample | | | | | |
| REC. Actual Length of Recovered Sample in Feet | | | | | |

**KERR-McGEE CORPORATION
HYDROLOGY DEPARTMENT
MONITORING WELL INSTALLATION DIAGRAM**

FLUSH
MOUNT

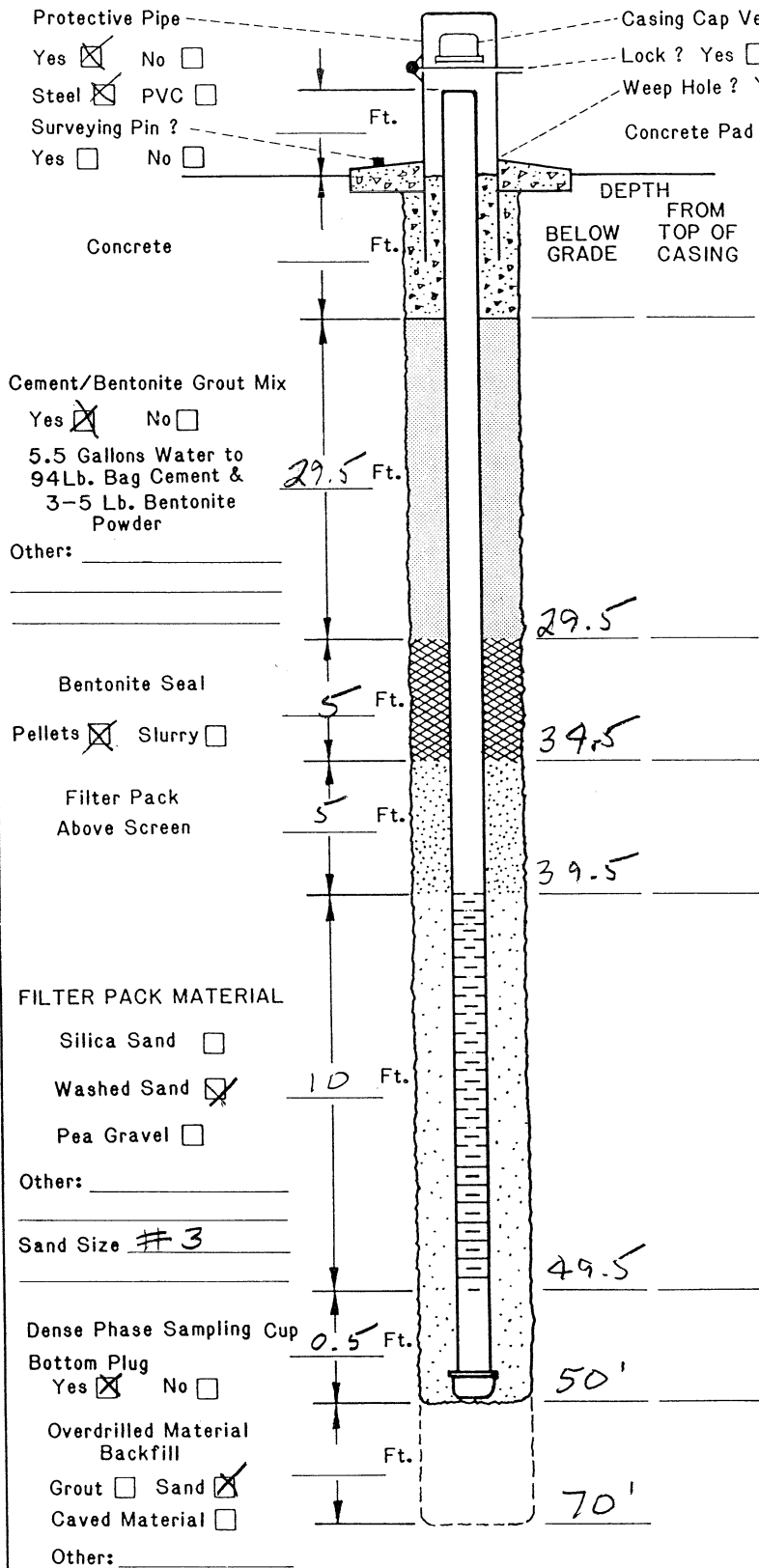

- DRILLING INFORMATION:**
- Borehole Diameter = 1 1/2 Inches.
 - Were Drilling Additives Used? Yes No
Revert Bentonite Water
Solid Auger Hollow Stem Auger
 - Was Outer Steel Casing Used? Yes No
Depth = _____ to _____ Feet.
 - Borehole Diameter for Outer Casing _____ Inches.
- WELL CONSTRUCTION INFORMATION:**
- Type of Casing: PVC Galvanized Teflon
Stainless Other _____
 - Type of Casing Joints: Screw-Couple Glue-Couple Other _____
 - Type of Well Screen: PVC Galvanized
Stainless Teflon Other _____
 - Diameter of Casing and Well Screen:
Casing 2" Inches, Screen 2" Inches.
 - Slot Size of Screen: 0.02
 - Type of Screen Perforation: Factory Slotted
Hacksaw Drilled Other _____
 - Installed Protector Pipe w/Lock: Yes No
- WELL DEVELOPMENT INFORMATION:**
- How was Well Developed? Bailing Pumping
Air Surging (Air or Nitrogen) Other _____
 - Time Spent on Well Development?
1 60 Minutes/Hours
 - Approximate Water Volume Removed? _____ Gallons
 - Water Clarity Before Development? Clear
Turbid Opaque
 - Water Clarity After Development? Clear
Turbid Opaque
 - Did Water have Odor? Yes No
If Yes, Describe _____
 - Did Water have any Color? Yes No
If Yes, Describe _____
- WATER LEVEL INFORMATION:**
Water Level Summary (From Top of Casing)
- During Drilling 24 Ft. Date 4-26-00
Before Development 12.45 Ft. Date 4-29-00
After Development 13.41 Ft. Date 5-11-00

Driller/Firm Compliance Drill Rig Type Mobile 53 Date Installed 4-26-00
Drill Crew Wells, Well No. PC 74 Kerr-McGee Hydrologist Ed Krish

SOIL BORING LOG KM-5655-B

| KERR-McGEE CORPORATION Hydrology Dept. - S&EA Division | | KM SUBSIDIARY KMC LLC | | LOCATION HENDERSON, NV | | BORING NUMBER PC 82 | | | | |
|---|--|--------------------------|---------------------------|---------------------------|-----------|------------------------|------|-------|------|--|
| DEPTH IN FEET | LITHOLOGIC DESCRIPTION | GRAPHIC LOG | UNIFIED SOIL FIELD CLASS. | BLOWS PER 6" | PID (ppm) | SOIL SAMPLE | | | | REMARKS OR FIELD OBSERVATIONS |
| | | | | | | NO. | TYPE | DEPTH | REC. | |
| 0-3 | disturbed berm material silty grav SAND | | SM-GM | | | | | | | @ 2' damp |
| 3-12 | silty gravelly SAND, dk brn, 20% silt, 40% granules & pea gravel (SR) of volc. 40% vf-vc sd, SA-SR | | SM-GM | | | | | | | ▽ @ 5' |
| 12-15 | sdly clay SILT, dk brn, 15-25% vf-m, SA-SR, sd, 20% clay, 10% sm volc granules, sticky | | ML | | | | | | | |
| 15-20 | silty sdly GRAVEL, dk brn, SR-SA, 20% silt, 25% vf-vc sd, SA-SR | | GM | | | | | | | |
| 20-30 | silty gravelly SAND, dk brn, 20% silt, 40% volc granules to pea gravel to 1/2" SR; vf-vc, SR-SA sd | | SM-GM | | | | | | | |
| 30-33 | sdly silty GRAVEL, dk brn, 30% SA-SR, vf-LSd, 20% silt, 50% volc w/ minor ls gravel to 2-3", SR | | GM | | | | | | | |
| 33-39 | silty gravelly SAND, as above | | SM-GM | | | | | | | @ 38'-39' gravel zone, volc SR up to 3" diam |
| 39-46 | silty SAND, brn, | | SM | | | | | | | |

EXPLANATION

- Water Table (24 Hour)
- Water Table (Time of Boring)
- PID Photoionization Detection (ppm) Identifies Sample by Number Sample Collection Method
- SPLIT-BARREL
- AUGER
- ROCK CORE
- THIN-WALLED TUBE
- CONTINUOUS SAMPLER
- NO RECOVERY

DEPTH Depth Top and Bottom of Sample
REC. Actual Length of Recovered Sample in Feet

GRAPHIC LOG LEGEND

- CLAY
- SILT
- SAND
- GRAVEL
- SILTY CLAY
- CLAYEY SILT
- DEBRIS FILL
- HIGHLY ORGANIC (PEAT)
- SANDY CLAY
- CLAYEY SAND

DATE DRILLED 5-4-00
PAGE 1 of 2
DRILLING METHOD HSA
DRILLED BY COMPLIANCE
LOGGED BY ED KRISH
EXISTING GRADE ELEVATION (FT. AMSL)
LOCATION OR GRID COORDINATES

SOIL BORING LOG KM-5655-B

| | | | |
|---|---------------------------|---------------------------|-----------------------|
| KERR-McGEE CORPORATION Hydrology Dept. - S&EA Division | KM SUBSIDIARY KMC LLLC | LOCATION HENDERSON, NV | BORING NUMBER PC82 |
|---|---------------------------|---------------------------|-----------------------|

| DEPTH IN FEET | LITHOLOGIC DESCRIPTION | GRAPHIC LOG | UNIFIED SOIL FIELD CLASS. | BLOWS PER 6' | PID (ppm) | SOIL SAMPLE | | | | REMARKS OR FIELD OBSERVATIONS |
|---------------|--|-------------|---------------------------|--------------|-----------|-------------|------|-------|------|-------------------------------|
| | | | | | | NO. | TYPE | DEPTH | REC. | |
| 45 | SA, 30% silt in 70% vf-f sd w/ minor c-vc grains sticky, calcareous | | SM | | | | | | | |
| 50 | 46-50 silty gravelly SAND, dk brn, as above | | SM-GM | | | | | | | |
| 52 | 50-52 clay, silty SAND, lt. red brn + grn gry. SA-SR vf-fg sd w/ 20% clay + 30% silt. Com sm caliche nodules, calcareous | | SM-SC | | | | | | | |
| 56 | 52-56 silty gravelly SAND, f-c SR-SA w/ 20% silt and 30% volc + ls pebbles to 2" | | SM-GM | | | | | | | Muddy ck @ 56' |
| 60 | 56-67 silty CLAY, lt grn yellow, sticky | | CL | | | | | | | |
| 67 | TD 67' | | | | | | | | | |

| | | | | |
|--|-------------------------------------|---------------------------|-------------------------------------|----------------|
| EXPLANATION | Water Table (24 Hour) | GRAPHIC LOG LEGEND | DATE DRILLED 5-4-00 | PAGE 2 of 2 |
| | Water Table (Time of Boring) | | DRILLING METHOD HSA | |
| | PID Photoionization Detection (ppm) | | DRILLED BY COMPLIANCE | |
| | NO. Identifies Sample by Number | | LOGGED BY ED KRISH | |
| | TYPE Sample Collection Method | | EXISTING GRADE ELEVATION (FT. AMSL) | |
| SPLIT-BARREL | AUGER | ROCK CORE | LOCATION OR GRID COORDINATES | |
| THIN-WALLED TUBE | CONTINUOUS SAMPLER | NO RECOVERY | | |
| DEPTH Depth Top and Bottom of Sample | | | | |
| REC. Actual Length of Recovered Sample in Feet | | | | |

**KERR-McGEE CORPORATION
HYDROLOGY DEPARTMENT
MONITORING WELL INSTALLATION DIAGRAM**

FLUSH
MOUNT

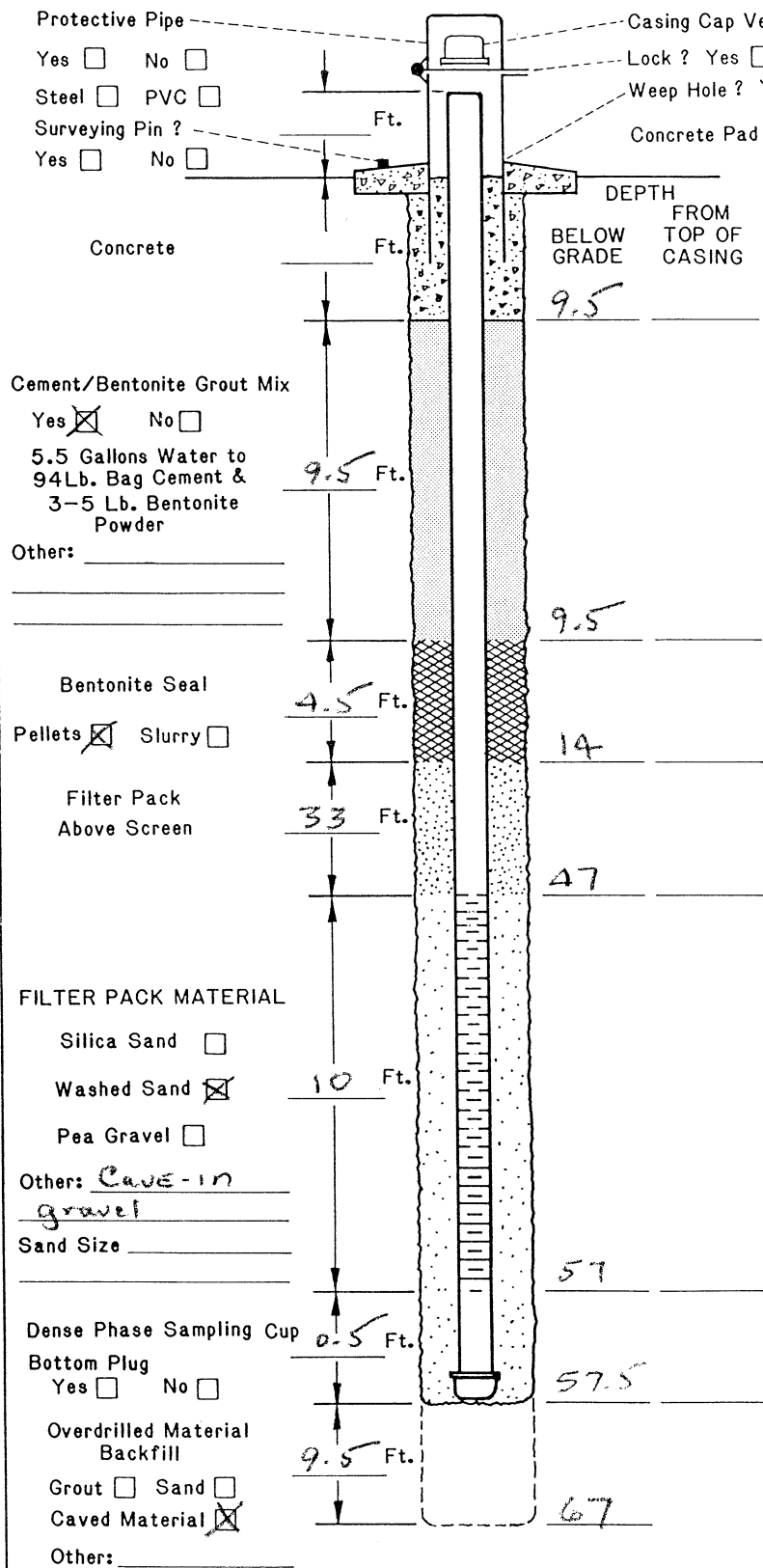

DRILLING INFORMATION:

- Borehole Diameter = 8 Inches.
- Were Drilling Additives Used? Yes No
Revert Bentonite Water
Solid Auger Hollow Stem Auger
- Was Outer Steel Casing Used? Yes No
Depth = _____ to _____ Feet.
- Borehole Diameter for Outer Casing _____ Inches.

WELL CONSTRUCTION INFORMATION:

- Type of Casing: PVC Galvanized Teflon
Stainless Other _____
- Type of Casing Joints: Screw-Couple Glue-Couple Other _____
- Type of Well Screen: PVC Galvanized
Stainless Teflon Other _____
- Diameter of Casing and Well Screens:
Casing 2 Inches, Screen 2 Inches.
- Slot Size of Screens: 0.020
- Type of Screen Perforation: Factory Slotted
Hacksaw Drilled Other _____
- Installed Protector Pipe w/Lock: Yes No

WELL DEVELOPMENT INFORMATION:

- How was Well Developed? Bailing Pumping
Air Surging (Air or Nitrogen) Other _____
- Time Spent on Well Development?
1 60 Minutes/Hours
- Approximate Water Volume Removed? _____ Gallons
- Water Clarity Before Development? Clear
Turbid Opaque
- Water Clarity After Development? Clear
Turbid Opaque
- Did Water have Odor? Yes No
If Yes, Describe _____
- Did Water have any Color? Yes No
If Yes, Describe _____

WATER LEVEL INFORMATION:

Water Level Summary (From Top of Casing)
During Drilling 5' Ft. Date 5-4-00
Before Development 4.91' Ft. Date 5-5-00
After Development 5.42' Ft. Date 5-11-00

Driller/Firm COMPLIANCE

Drill Rig Type MOBILE B-59

Date Installed 5-4-00

Drill Crew WELLS

Well No. PC82

Kerr-McGee Hydrologist ED KRISH

SOIL BORING LOG KM-5655-B

| KERR-McGEE CORPORATION Hydrology Dept. - S&EA Division | | KM SUBSIDIARY KMC LLC | | LOCATION HENDERSON, NV | | BORING NUMBER PC 83 | | | | |
|--|--|---------------------------------|---------------------------|----------------------------------|-------------------------------------|-------------------------------|------------------------------|-------------------|---------------|-------------------------------|
| DEPTH IN FEET | LITHOLOGIC DESCRIPTION | GRAPHIC LOG | UNIFIED SOIL FIELD CLASS. | BLOWS PER 6" | PID (ppm) | SOIL SAMPLE | | | | REMARKS OR FIELD OBSERVATIONS |
| | | | | | | NO. | TYPE | DEPTH | REC. | |
| 5 10 15 20 25 30 35 | PC 83 is 11' NORTH of PC 82. See log for PC 82 for lithology | | | | | | | | | ▽ @ 5' 5-4-00 |
| | 37' TD | | | | | | | | | |
| EXPLANATION | ▼ Water Table (24 Hour) | | GRAPHIC LOG LEGEND | | | | DATE DRILLED | PAGE | | |
| | ▽ Water Table (Time of Boring) | | | | | | CLAY | DEBRIS FILL | 5-4-00 | 1 of 1 |
| | PID NO. TYPE Photoionization Detection (ppm) Identifies Sample by Number Sample Collection Method | | SILT | HIGHLY ORGANIC (PEAT) | DRILLING METHOD | | HSA | | | |
| | SPLIT-BARREL | AUGER | ROCK CORE | SAND | SANDY CLAY | DRILLED BY | | COMPLIANCE | | |
| | THIN-WALLED TUBE | CONTINUOUS SAMPLER | NO RECOVERY | GRAVEL | CLAYEY SAND | LOGGED BY | | ED KRISH | | |
| DEPTH Depth Top and Bottom of Sample REC. Actual Length of Recovered Sample in Feet | | SILTY CLAY | CLAYEY SILT | _____ | EXISTING GRADE ELEVATION (FT. AMSL) | | LOCATION OR GRID COORDINATES | | | |

**KERR-McGEE CORPORATION
HYDROLOGY DEPARTMENT
MONITORING WELL INSTALLATION DIAGRAM**

1-FLUSH MOUNT

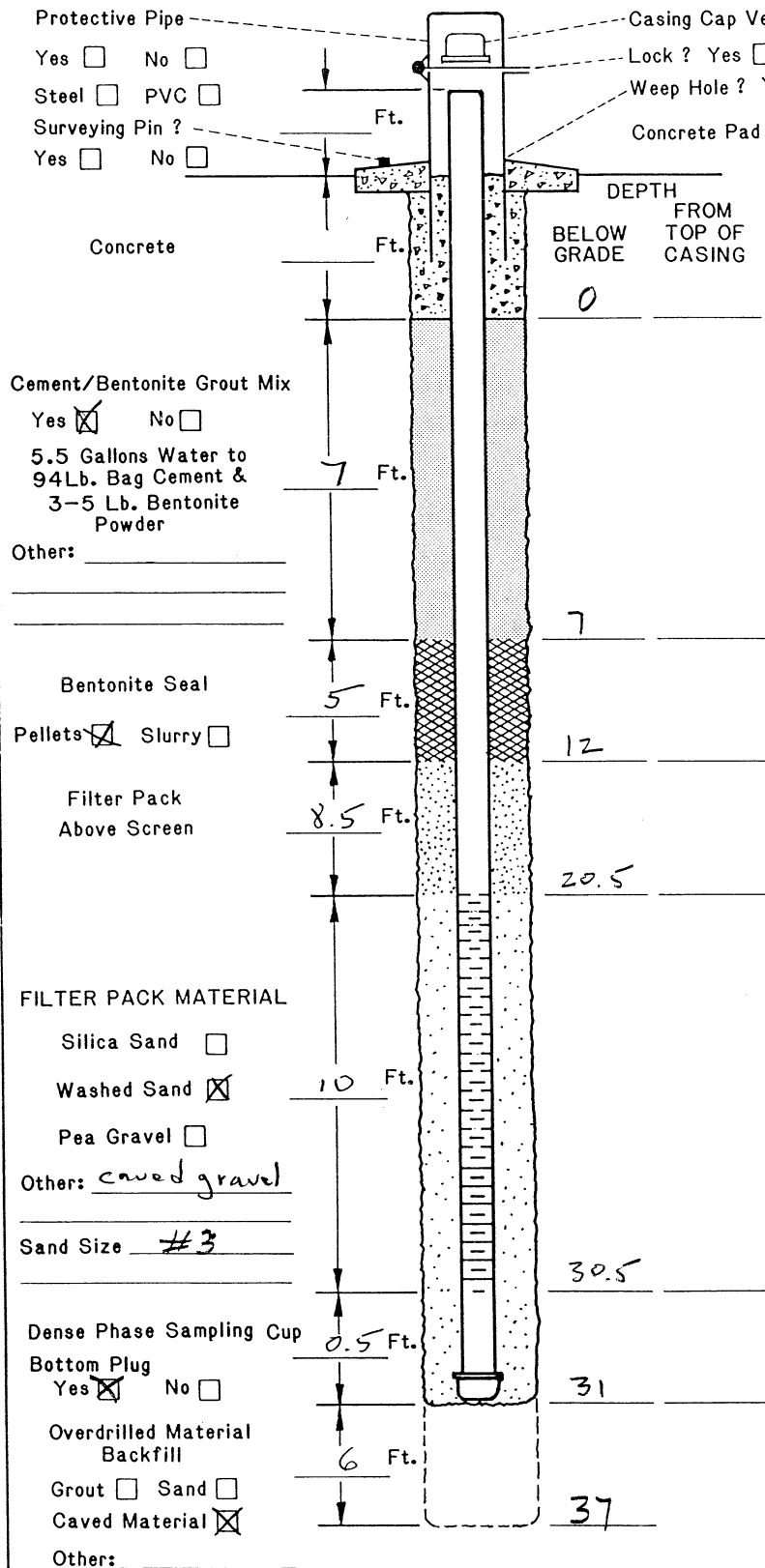

Protective Pipe
Yes No
Steel PVC
Surveying Pin?
Yes No

Casing Cap Vent? Yes No
Lock? Yes No
Weep Hole? Yes No

Concrete Pad _____ Ft. x _____ Ft. x _____ Inches

DRILLING INFORMATION:

- Borehole Diameter = 8 Inches.
- Were Drilling Additives Used? Yes No
Revert Bentonite Water
Solid Auger Hollow Stem Auger
- Was Outer Steel Casing Used? Yes No
Depth = _____ to _____ Feet.
- Borehole Diameter for Outer Casing _____ Inches.

WELL CONSTRUCTION INFORMATION:

- Type of Casing: PVC Galvanized Teflon
Stainless Other _____
- Type of Casing Joints: Screw-Couple Glue-Couple Other _____
- Type of Well Screen: PVC Galvanized
Stainless Teflon Other _____
- Diameter of Casing and Well Screen:
Casing 2 Inches, Screen 2 Inches.
- Slot Size of Screen: 0.020
- Type of Screen Perforation: Factory Slotted
Hacksaw Drilled Other _____
- Installed Protector Pipe w/Lock: Yes No

WELL DEVELOPMENT INFORMATION:

- How was Well Developed? Bailing Pumping
Air Surging (Air or Nitrogen) Other _____
- Time Spent on Well Development?
1.60 Minutes/Hours
- Approximate Water Volume Removed? _____ Gallons
- Water Clarity Before Development? Clear
Turbid Opaque
- Water Clarity After Development? Clear
Turbid Opaque
- Did Water have Odor? Yes No
If Yes, Describe _____
- Did Water have any Color? Yes No
If Yes, Describe _____

WATER LEVEL INFORMATION:

Water Level Summary (From Top of Casing)
During Drilling 5' Ft. Date 5-4-00
Before Development 3.82' Ft. Date 5-11-00
After Development _____ Ft. Date _____

Driller/Firm COMPLIANCE

Drill Rig Type Mobile B-59

Date Installed 5-5-00

Drill Crew WELLS

Well No. PC 83

Kerr-McGee Hydrologist ED KRISH

SOIL BORING LOG KM-5655-B

| KERR-McGEE CORPORATION Hydrology Dept. - S&EA Division | | KM SUBSIDIARY KMC LLC | | LOCATION HENDERSON, NV | | BORING NUMBER PC 88 | | | | |
|---|---|--------------------------|---------------------------|---------------------------|-----------|------------------------|------|-------|------|-------------------------------|
| DEPTH IN FEET | LITHOLOGIC DESCRIPTION | GRAPHIC LOG | UNIFIED SOIL FIELD CLASS. | BLOWS PER 6" | PID (ppm) | SOIL SAMPLE | | | | REMARKS OR FIELD OBSERVATIONS |
| | | | | | | NO. | TYPE | DEPTH | REC. | |
| 5 | 0-12 sdy GRAVEL, pale brn (5YR 5/2). 10% silt, 30% sd (SA-SR, vf-vc) and 60% volc gravel (SA-SR, up to 3" diam. | | GW | | | | | | | damp @ 0' @ 2' |
| 15 | 12-51 silty gravelly SAND. pale yell brn (10YR 6/2). Var. silt 20-40%. 20-30% pea gravel to 3/4" (volc). Sand SA-SR vf-vc | | SM-GM | | | | | | | |
| 20 | 12-21 10-20% silty matrix | | | | | | | | | |
| 25 | 21-51 com silt in matrix 30-40% | | | | | | | | | |
| 30 | 27-33 gravel zone w/ pebbles to 3". Var. caliche cement | | | | | | | | | |
| 35 | 32-33 v. hard. slow drilling abu caliche cement | | | | | | | | | |
| | 37-51 Var. amts of gravel (pebbles to 2") up to 50% | | | | | | | | | |

EXPLANATION

- Water Table (24 Hour)
- Water Table (Time of Boring)
- PID Photoionization Detection (ppm)
- NO. Identifies Sample by Number
- TYPE Sample Collection Method
- SPLIT-BARREL
- AUGER
- ROCK CORE
- THIN-WALLED TUBE
- CONTINUOUS SAMPLER
- NO RECOVERY

DEPTH Depth Top and Bottom of Sample
REC. Actual Length of Recovered Sample in Feet

GRAPHIC LOG LEGEND

- CLAY
- SILT
- SAND
- GRAVEL
- SILTY CLAY
- CLAYEY SILT
- DEBRIS FILL
- HIGHLY ORGANIC (PEAT)
- SANDY CLAY
- CLAYEY SAND

DATE DRILLED 5-11-00 PAGE 1 of 2

DRILLING METHOD HSA

DRILLED BY COMPLIANCE

LOGGED BY ED KRISH

EXISTING GRADE ELEVATION (FT AMSL)

LOCATION OR GRID COORDINATES

SOIL BORING LOG KM-5655-B

| KERR-McGEE CORPORATION Hydrology Dept. - S&EA Division | | KM SUBSIDIARY KMC LLC | | LOCATION HENDERSON, NV | | BORING NUMBER PC 88 | | | | | |
|--|---|--------------------------|---------------------------|---------------------------|-----------|---|------|-------|------|--|--|
| DEPTH IN FEET | LITHOLOGIC DESCRIPTION | GRAPHIC LOG | UNIFIED SOIL FIELD CLASS. | BLOWS PER 6" | PID (ppm) | SOIL SAMPLE | | | | REMARKS OR FIELD OBSERVATIONS | |
| | | | | | | NO. | TYPE | DEPTH | REC. | | |
| 45 | NOTE: Most likely this unit is a series of fluvial fining-upward sediment, from gravels to silts | | SM GM | | | | | | | | |
| 51 | 51-62 silty CLAY, grn gry (5G78/2) and yell gry (5Y8/1) | | CL | | | | | | | MC @ 51' | |
| 55 | | | | | | | | | | | |
| 60 | | | | | | | | | | | |
| 62 | TD 62' | | | | | | | | | | |
| EXPLANATION ▼ Water Table (24 Hour) ▽ Water Table (Time of Boring) PID Photoionization Detection (ppm) NO. Identifies Sample by Number TYPE Sample Collection Method SPLIT. BARREL AUGER ROCK CORE THIN-WALLED TUBE CONTINUOUS SAMPLER NO RECOVERY | | | | | | GRAPHIC LOG LEGEND CLAY DEBRIS FILL SILT HIGHLY ORGANIC (PEAT) SAND SANDY CLAY GRAVEL CLAYEY SAND SILTY CLAY CLAYEY SILT | | | | DATE DRILLED 5-12-00 PAGE 2 of 2 DRILLING METHOD HSA DRILLED BY COMPLIANCE LOGGED BY ED KRISH EXISTING GRADE ELEVATION (FT AMSL) LOCATION OR GRID COORDINATES | |

**KERR-McGEE CORPORATION
HYDROLOGY DEPARTMENT
MONITORING WELL INSTALLATION DIAGRAM**

FLUSH MOUNT

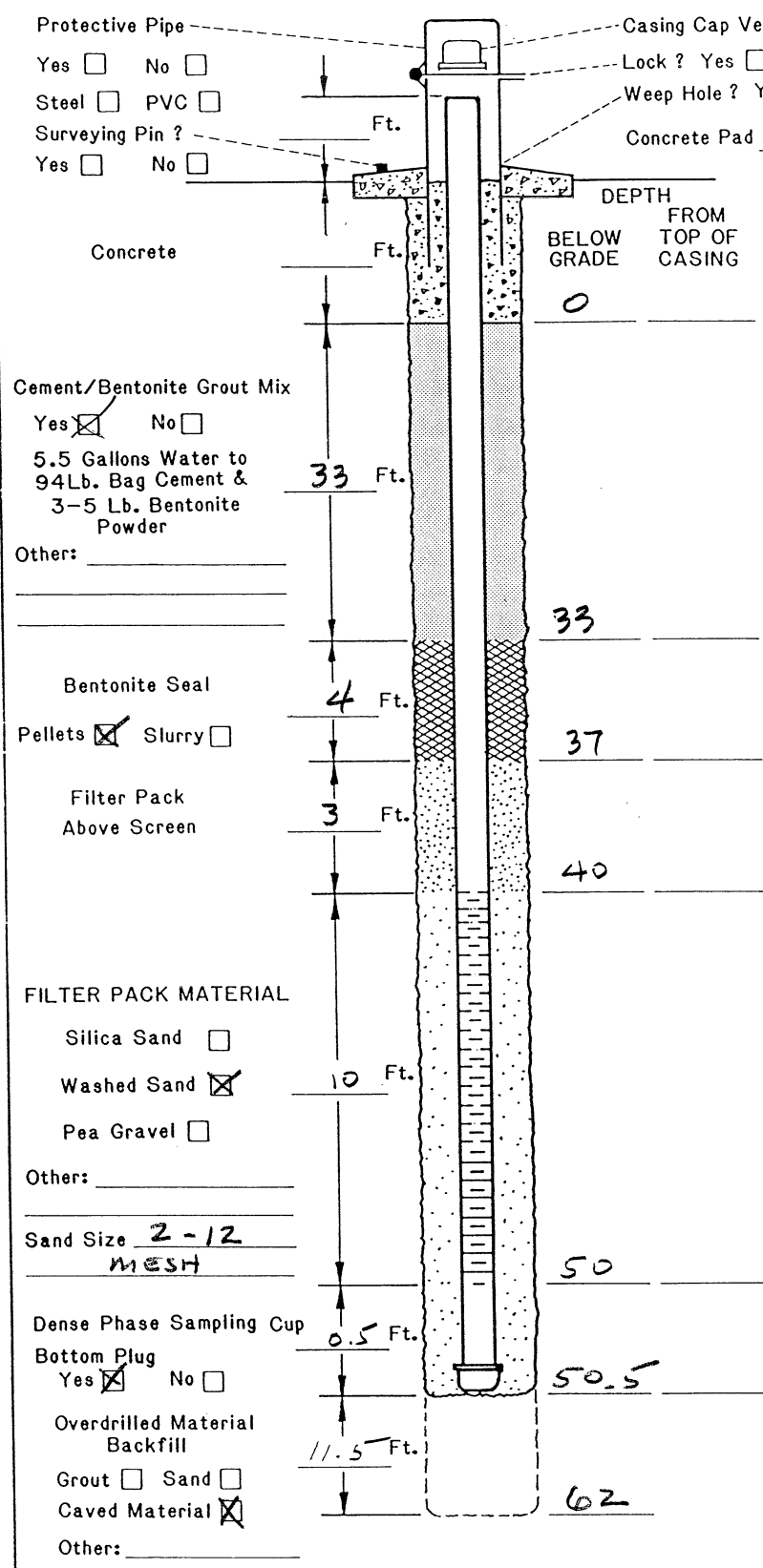

DRILLING INFORMATION:

- Borehole Diameter = 8 Inches.
- Were Drilling Additives Used? Yes No
Revert Bentonite Water
Solid Auger Hollow Stem Auger
- Was Outer Steel Casing Used? Yes No
Depth = _____ to _____ Feet.
- Borehole Diameter for Outer Casing _____ Inches.

WELL CONSTRUCTION INFORMATION:

- Type of Casing: PVC Galvanized Teflon
Stainless Other _____
- Type of Casing Joints: Screw-Couple Glue-Couple Other _____
- Type of Well Screen: PVC Galvanized
Stainless Teflon Other _____
- Diameter of Casing and Well Screens:
Casing 2 Inches, Screen 2 Inches.
- Slot Size of Screens: 0.020
- Type of Screen Perforation: Factory Slotted
Hacksaw Drilled Other _____
- Installed Protector Pipe w/Lock: Yes No

WELL DEVELOPMENT INFORMATION:

- How was Well Developed? Bailing Pumping
Air Surging (Air or Nitrogen) Other _____
- Time Spent on Well Development?
_____ / 60 Minutes/Hours
- Approximate Water Volume Removed? _____ Gallons
- Water Clarity Before Development? Clear
Turbid Opaque
- Water Clarity After Development? Clear
Turbid Opaque
- Did Water have Odor? Yes No
If Yes, Describe _____
- Did Water have any Color? Yes No
If Yes, Describe _____

WATER LEVEL INFORMATION:

Water Level Summary (From Top of Casing)
During Drilling 2' Ft. Date 5-11-00
Before Development 0.21' Ft. Date 5-13-00
After Development _____ Ft. Date _____

Driller/Firm COMPLIANCE

Drill Rig Type MOBILE B-59 Date Installed 5-11-00

Drill Crew WELLS

Well No. PC 88

Kerr-McGee Hydrologist ED KRISH

SOIL BORING LOG KM-5655-B

| KERR-McGEE CORPORATION Hydrology Dept. - S&EA Division | | KM SUBSIDIARY KMC LLC | | LOCATION HENDERSON, NV | | BORING NUMBER PC 89 | | | | | | |
|---|---|---------------------------------|---------------------------|---------------------------|-----------|-------------------------------|------|-------|------|-------------------------------|-------------|--|
| DEPTH IN FEET | LITHOLOGIC DESCRIPTION | GRAPHIC LOG | UNIFIED SOIL FIELD CLASS. | BLOWS PER 6" | PID (ppm) | SOIL SAMPLE | | | | REMARKS OR FIELD OBSERVATIONS | | |
| | | | | | | NO. | TYPE | DEPTH | REC. | | | |
| 5 | PC 89 located 7' east of PC 88. See log of PC 88 for lithology | | | | | | | | | | <u>▽ 2'</u> | |
| 10 | | | | | | | | | | | | |
| 15 | | | | | | | | | | | | |
| 20 | | | | | | | | | | | | |
| 25 | | | | | | | | | | | | |
| 30 | | | | | | | | | | | | |
| 35 | | | | | | | | | | | | |
| 39 | TD 39' | | | | | | | | | | | |

| | | | | | | |
|--------------------|--------------------------|---------------------------------|---------------------------|------|--------------|-------------------------------------|
| EXPLANATION | ▼ | Water Table (24 Hour) | GRAPHIC LOG LEGEND | | DATE DRILLED | PAGE |
| | ▽ | Water Table (Time of Boring) | ▨ | CLAY | ▩ | DEBRIS FILL |
| | PID | Photoionization Detection (ppm) | ▧ | SILT | ▤ | HIGHLY ORGANIC (PEAT) |
| | NO. | Identifies Sample by Number | ▩ | SAND | ▧ | SANDY CLAY |
| TYPE | Sample Collection Method | ▩ | GRAVEL | ▧ | CLAYEY SAND | DRILLING METHOD |
| ▨ | SPLIT-BARREL | ▩ | AUGER | ▩ | ROCK CORE | HSA |
| ▩ | THIN-WALLED TUBE | ▩ | CONTINUOUS SAMPLER | ▩ | NO RECOVERY | DRILLED BY |
| | | ▩ | | ▩ | | COMPLIANCE |
| | | ▩ | | ▩ | | LOGGED BY |
| | | ▩ | | ▩ | | ED KRISH |
| | | ▩ | | ▩ | | EXISTING GRADE ELEVATION (FT. AMSL) |
| | | ▩ | | ▩ | | LOCATION OR GRID COORDINATES |
| | | ▩ | | ▩ | | |

**KERR-McGEE CORPORATION
HYDROLOGY DEPARTMENT
MONITORING WELL INSTALLATION DIAGRAM**

FLUSH
MOUNT

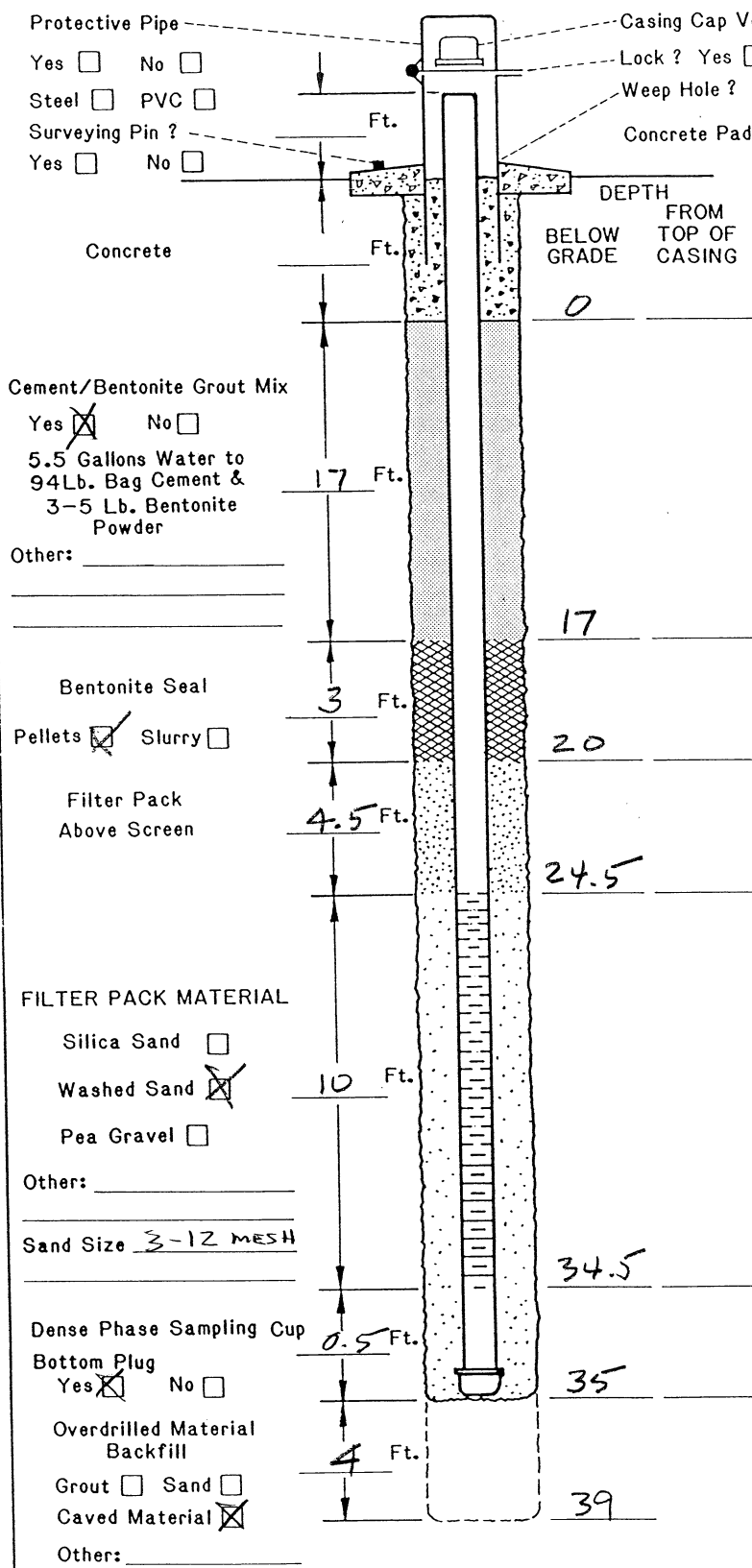

- DRILLING INFORMATION:**
- Borehole Diameter = 8 Inches.
 - Were Drilling Additives Used? Yes No
Revert Bentonite Water
Solid Auger Hollow Stem Auger
 - Was Outer Steel Casing Used? Yes No
Depth = _____ to _____ Feet.
 - Borehole Diameter for Outer Casing _____ Inches.

- WELL CONSTRUCTION INFORMATION:**
- Type of Casing: PVC Galvanized Teflon
Stainless Other _____
 - Type of Casing Joints: Screw-Couple Glue-Couple Other _____
 - Type of Well Screen: PVC Galvanized
Stainless Teflon Other _____
 - Diameter of Casing and Well Screen:
Casing 2 Inches, Screen 2 Inches.
 - Slot Size of Screen: 0.020
 - Type of Screen Perforation: Factory Slotted
Hacksaw Drilled Other _____
 - Installed Protector Pipe w/Lock: Yes No

- WELL DEVELOPMENT INFORMATION:**
- How was Well Developed? Bailing Pumping
Air Surging (Air or Nitrogen) Other _____
 - Time Spent on Well Development? _____
1 60 Minutes/Hours
 - Approximate Water Volume Removed? _____ Gallons
 - Water Clarity Before Development? Clear
Turbid Opaque
 - Water Clarity After Development? Clear
Turbid Opaque
 - Did Water have Odor? Yes No
If Yes, Describe _____
 - Did Water have any Color? Yes No
If Yes, Describe _____

WATER LEVEL INFORMATION:
Water Level Summary (From Top of Casing)

During Drilling 2 Ft. Date 5-12-00
Before Development +0.08' Ft. Date 5-13-00
After Development _____ Ft. Date _____

Driller/Firm COMPLIANCE Drill Rig Type Mobile B-59 Date Installed 5-12-00
Drill Crew WELLS Well No. PC 89 Kerr-McGee Hydrologist ED KRISH

SOIL BORING LOG KM-5655-B

| KERR-McGEE CORPORATION Hydrology Dept. - S&EA Division | | KM SUBSIDIARY KMC LLC | | LOCATION HENDERSON, NV | | BORING NUMBER PC97 | | | | |
|---|---|---------------------------------|---------------------------|----------------------------------|------------------------------|------------------------------------|--------------------------------|----------------|-----------------|-------------------------------|
| DEPTH IN FEET | LITHOLOGIC DESCRIPTION | GRAPHIC LOG | UNIFIED SOIL FIELD CLASS. | BLOWS PER 6" | PID (ppm) | SOIL SAMPLE | | | | REMARKS OR FIELD OBSERVATIONS |
| | | | | | | NO. | TYPE | DEPTH | REC. | |
| 5 | <u>0-5</u> BERM material brn silty gravelly SAND | | SW | | | | | | | damp @ 3' |
| 10 | <u>5-20</u> silty gravelly SAND, pale brn (5YR5/2) 10% silt, 25% volc granules and sm pebbles up to 1" diam Sand w vf-vc, SA-SR | | SW | | | | | | | ▽ @ 6' |
| 20 | <u>20-25</u> silty SAND w/ minor gravel. pale yell brn (10YR 6/2). Silt up to 25%, gravel (gran. + pea size up to 20%, Sand as above... vf-vc, SR-SA. | | SM | | | | | | | |
| 30 | <u>25-36</u> silty sdy GRAVEL pale yell brn (10YR 6/2). 25% silt, 25% vf-vc, SA-SR. Gravel 50%, SR-SA, granules and pebbles to 2" diam locally com caliche cement | | GW | | | | | | | |
| 36 | <u>36-42</u> silty SAND pale yell brn (10YR 6/2) bimodal: vf-fg w/com. | | SM | | | | | | | |
| EXPLANATION | ▼ Water Table (24 Hour) | | GRAPHIC LOG LEGEND | | | | DATE DRILLED 5-16-00 | PAGE 1 of 2 | | |
| | ▽ Water Table (Time of Boring) PID Photoionization Detection (ppm) NO. Identifies Sample by Number TYPE Sample Collection Method | SPLIT-BARREL | | CLAY | SILT | SAND | GRAVEL | SILTY CLAY | CLAYEY SILT | |
| | AUGER | ROCK CORE | DEBRIS FILL | HIGHLY ORGANIC (PEAT) | SANDY CLAY | CLAYEY SAND | DRILLING METHOD HSA | | | |
| | THIN-WALLED TUBE | CONTINUOUS SAMPLER | NO RECOVERY | DRILLED BY COMPLIANCE | LOGGED BY ED KRISH | EXISTING GRADE ELEVATION (FT AMSL) | LOCATION OR GRID COORDINATES | | | |
| | DEPTH Depth Top and Bottom of Sample REC. Actual Length of Recovered Sample in Feet | | | | | | | | | |

SOIL BORING LOG KM-5655-B

| KERR-MCGEE CORPORATION Hydrology Dept. - S&EA Division | | KM SUBSIDIARY KMC LLC | | LOCATION HENDERSON NV | | BORING NUMBER PC97 | | | | |
|---|---|---------------------------------|---------------------------|---------------------------------|-----------|------------------------------|------|-------|------|-------------------------------|
| DEPTH IN FEET | LITHOLOGIC DESCRIPTION | GRAPHIC LOG | UNIFIED SOIL FIELD CLASS. | BLOWS PER 6" | PID (ppm) | SOIL SAMPLE | | | | REMARKS OR FIELD OBSERVATIONS |
| | | | | | | NO. | TYPE | DEPTH | REC. | |
| 42 | c-vc, SR, Sand. 25% silt in matrix. Calcareous | | SM | | | | | | | |
| 43 | 42-43 silty gravelly SAND pale yell brn. Gravels up to 3/4" diam w/ minor caliche cement, calcareous | | SW | | | | | | | dense + dry |
| 45 | 43-45 clay sdy SILT lt grn gry (5GY 8/1), 10-20% clay in matrix, 10-20% v-fg sand. Calcareous, w/ minor sm. caliche nodules | | ML-CL | | | | | | | MC @ 43 |
| | TD 45' | | | | | | | | | |

EXPLANATION

- Water Table (24 Hour)
- Water Table (Time of Boring)
- PID Photoionization Detection (ppm)
- NO. Identifies Sample by Number
- TYPE Sample Collection Method
- SPLIT-BARREL
- AUGER
- ROCK CORE
- THIN-WALLED TUBE
- CONTINUOUS SAMPLER
- NO RECOVERY

DEPTH: Depth Top and Bottom of Sample
 REC.: Actual Length of Recovered Sample in Feet

GRAPHIC LOG LEGEND

| | | | |
|--|-------------|--|-----------------------|
| | CLAY | | DEBRIS FILL |
| | SILT | | HIGHLY ORGANIC (PEAT) |
| | SAND | | SANDY CLAY |
| | GRAVEL | | CLAYEY SAND |
| | SILTY CLAY | | |
| | CLAYEY SILT | | |

DATE DRILLED: **5-16-00** PAGE: **2 of 2**

DRILLING METHOD: **HSA**

DRILLED BY: **COMPLIANCE**

LOGGED BY: **ED KRISH**

EXISTING GRADE ELEVATION (FT AMSL):

LOCATION OR GRID COORDINATES:

**KERR-McGEE CORPORATION
HYDROLOGY DEPARTMENT
MONITORING WELL INSTALLATION DIAGRAM**

FLUSH
MOUNT

Protective Pipe
Yes No
Steel PVC
Surveying Pin? Yes No

Casing Cap Vent? Yes No
Lock? Yes No
Weep Hole? Yes No

Concrete Pad _____ Ft. x _____ Ft. x _____ Inches

DRILLING INFORMATION:

- Borehole Diameter = 8 Inches.
- Were Drilling Additives Used? Yes No
Revert Bentonite Water
Solid Auger Hollow Stem Auger
- Was Outer Steel Casing Used? Yes No
Depth = _____ to _____ Feet.
- Borehole Diameter for Outer Casing _____ Inches.

WELL CONSTRUCTION INFORMATION:

- Type of Casing: PVC Galvanized Teflon
Stainless Other _____
- Type of Casing Joints: Screw-Couple Glue-Couple Other _____
- Type of Well Screen: PVC Galvanized
Stainless Teflon Other _____
- Diameter of Casing and Well Screen:
Casing 2 Inches, Screen 2 Inches.
- Slot Size of Screen: 0.020
- Type of Screen Perforations: Factory Slotted
Hacksaw Drilled Other _____
- Installed Protector Pipe w/Lock: Yes No

WELL DEVELOPMENT INFORMATION:

- How was Well Developed? Bailing Pumping
Air Surging (Air or Nitrogen) Other _____
- Time Spent on Well Development?
1 60 Minutes/Hours
- Approximate Water Volume Removed? _____ Gallons
- Water Clarity Before Development? Clear
Turbid Opaque
- Water Clarity After Development? Clear
Turbid Opaque
- Did Water have Odor? Yes No
If Yes, Describe _____
- Did Water have any Color? Yes No
If Yes, Describe _____

WATER LEVEL INFORMATION:

Water Level Summary (From Top of Casing)
During Drilling 6' Ft. Date 5-16-00
Before Development 0.26' Ft. Date 5-17-00
After Development _____ Ft. Date _____

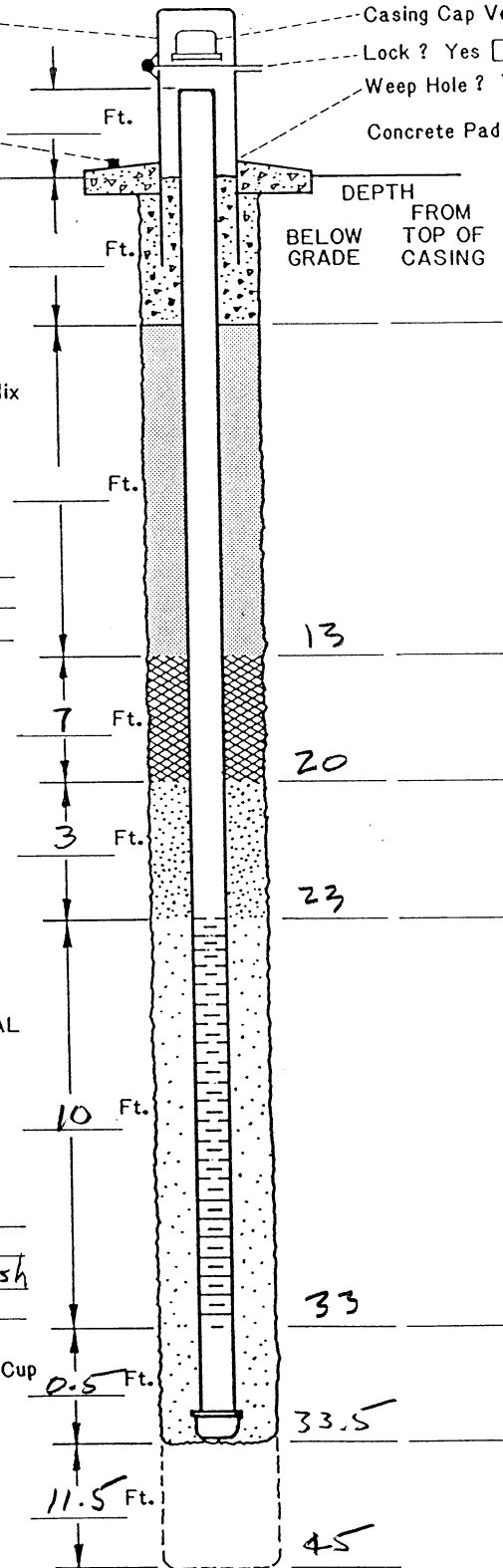

Cement/Bentonite Grout Mix

Yes No

5.5 Gallons Water to
94Lb. Bag Cement &
3-5 Lb. Bentonite
Powder

Other: _____

Bentonite Seal

Pellets Slurry

Filter Pack
Above Screen

FILTER PACK MATERIAL

Silica Sand

Washed Sand

Pea Gravel

Other: _____

Sand Size 2-12 mesh

Dense Phase Sampling Cup

Bottom Plug
Yes No

Overdrilled Material
Backfill

Grout Sand

Caved Material

Other: _____

Driller/Firm COMPLIANCE

Drill Rig Type Mobile B-29 Date Installed 5-16-00

Drill Crew WELLS

Well No. PC 97

Kerr-McGee
Hydrologist ED KRISH

SOIL BORING LOG KM-5655-B

| | | | |
|---|--------------------------|---------------------------|-------------------------|
| KERR-McGEE CORPORATION Hydrology Dept. - S&EA Division | KM SUBSIDIARY KMC LLC | LOCATION Henderson, NV | BORING NUMBER PC 104 |
|---|--------------------------|---------------------------|-------------------------|

| DEPTH IN FEET | LITHOLOGIC DESCRIPTION | GRAPHIC LOG | UNIFIED SOIL FIELD CLASS. | BLOWS PER 6" | PID (ppm) | SOIL SAMPLE | | | | REMARKS OR FIELD OBSERVATIONS |
|---------------|---|-------------|---------------------------|--------------|-----------|-------------|------|-------|------|-------------------------------|
| | | | | | | NO. | TYPE | DEPTH | REC. | |
| 0-6 | Berm Material sdy, gravelly mix | | | | | | | | | |
| 6-21 | SAND, gravelly & silty. Brn (5YR 5/4). 10-20% silt in sd matrix of f-c g w/mm or veg. SA-SR. 20-30% SA-SR, volc pea gravel to 3/4" w/ locally thin zones to 2". Non-calcareous. 6-12' com gravel to 2" | | SW | | | | | | | |
| 21-35 | GRAVEL & sdy GRAVEL, interbedded, brn (5YR 5/4). Volc clasts up to 1" except locally to 5". SA-SR, contains var. amts of vf-vc, SA-SR sd. +r silt 23-26' com lg gravel to 4" | | GP/GM | | | | | | | damp @ 21' wet @ 22' |
| 29-30 | silty gravelly SAND vf-vc w/ 20-30% silt | | | | | | | | | |
| 34-35 | com lg gravel to 5" | | | | | | | | | |
| 35-36 | CLAY, silty, gry yell grn (5GY 7/2). 10-20% silt in matrix, non-calcareous. Tr-sp gypsum TD @ 36' | | CL | | | | | | | MC @ 35' |

| | | | | | | |
|---|--|---------------------------|-----------------------|------------------------------------|-----------------------|--|
| EXPLANATION | Water Table (24 Hour) | GRAPHIC LOG LEGEND | | DATE DRILLED 2-3-01 | PAGE 1 of 1 | |
| | Water Table (Time of Boring) | CLAY | DEBRIS FILL | DRILLING METHOD PERCUSSION | | |
| | PID NO. TYPE Photoionization Detection (ppm) Identifies Sample by Number Sample Collection Method | SILT | HIGHLY ORGANIC (PEAT) | DRILLED BY LAYNE | | |
| | SPLIT-BARREL | AUGER | SAND | SANDY CLAY | LOGGED BY Ed Krish | |
| THIN-WALLED TUBE | CONTINUOUS SAMPLER | GRAVEL | CLAYEY SAND | EXISTING GRADE ELEVATION (FT AMSL) | | |
| ROCK CORE | NO RECOVERY | SILTY CLAY | CLAYEY SILT | LOCATION OR GRID COORDINATES | | |
| DEPTH Depth Top and Bottom of Sample | REC. Actual Length of Recovered Sample in Feet | | | | | |

KERR-McGEE CORPORATION HYDROLOGY DEPARTMENT MONITORING WELL INSTALLATION DIAGRAM

FLUSH
MOUNT

Protective Pipe
Yes No
Steel PVC
Surveying Pin?
Yes No

Casing Cap Vent? Yes No
Lock? Yes No
Weep Hole? Yes No

Concrete Pad _____ Ft. x _____ Ft. x _____ Inches

Concrete 6.5 Ft. DEPTH FROM TOP OF CASING BELOW GRADE

DRILLING INFORMATION:

1. Borehole Diameter = 9 Inches.
2. Were Drilling Additives Used? Yes No
Revert Bentonite Water
Solid Auger Hollow Stem Auger
3. Was Outer Steel Casing Used? Yes No
Depth = _____ to _____ Feet.
4. Borehole Diameter for Outer Casing _____ Inches.

Cement/Bentonite Grout Mix

Yes No
5.5 Gallons Water to
94Lb. Bag Cement &
3-5 Lb. Bentonite
Powder

Other: _____

WELL CONSTRUCTION INFORMATION:

1. Type of Casing: PVC Galvanized Teflon
Stainless Other _____
2. Type of Casing Joints: Screw-Couple Glue-Couple Other _____
3. Type of Well Screens: PVC Galvanized
Stainless Teflon Other _____
4. Diameter of Casing and Well Screens:
Casing 2 Inches, Screen 2 Inches.
5. Slot Size of Screen: 0.020
6. Type of Screen Perforations: Factory Slotted
Hacksaw Drilled Other _____
7. Installed Protector Pipe w/Lock: Yes No

Bentonite Seal

Pellets Slurry

Filter Pack
Above Screen

FILTER PACK MATERIAL

Silica Sand

Washed Sand

Pea Gravel

Other: _____

Sand Size 3-12

Dense Phase Sampling Cup

Bottom Plug
Yes No

Overdrilled Material
Backfill

Grout Sand

Caved Material

Other: _____

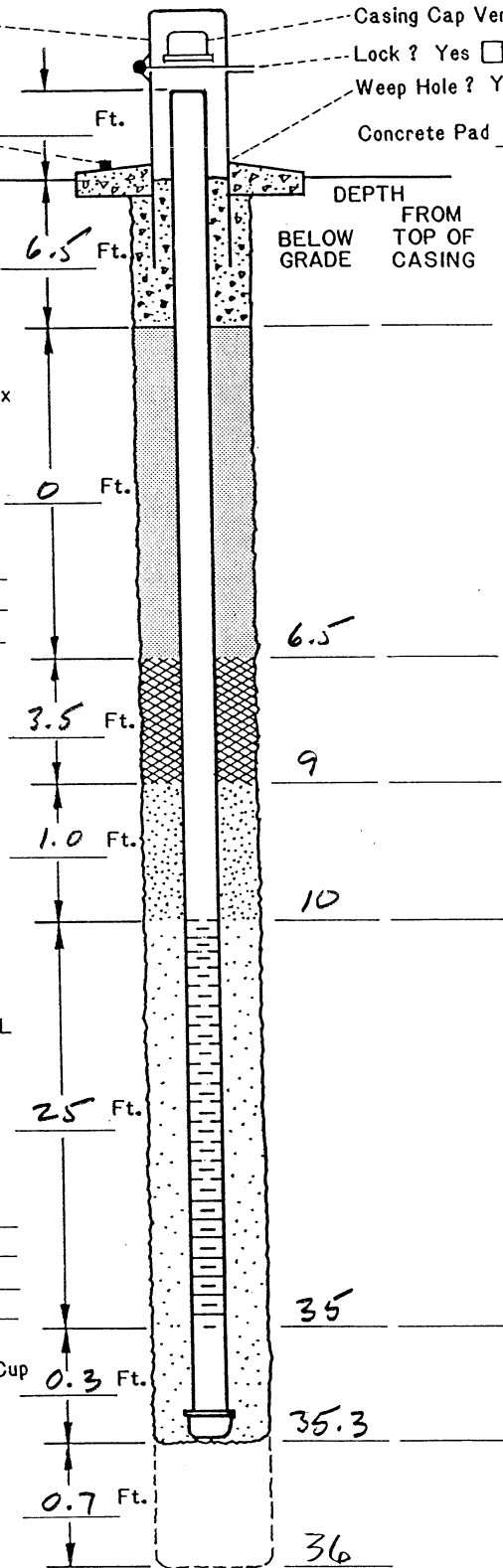

WELL DEVELOPMENT INFORMATION:

1. How was Well Developed? Bailing Pumping
Air Surging (Air or Nitrogen) Other _____
2. Time Spent on Well Development?
_____/_____/_____ Minutes/Hours
3. Approximate Water Volume Removed? _____ Gallons
4. Water Clarity Before Development? Clear
Turbid Opaque
5. Water Clarity After Development? Clear
Turbid Opaque
6. Did Water have Odeur? Yes No
If Yes, Describe _____
7. Did Water have any Color? Yes No
If Yes, Describe _____

WATER LEVEL INFORMATION:

Water Level Summary (From Top of Casing)

During Drilling 22 Ft. Date 2-3-01

Before Development _____ Ft. Date _____

After Development _____ Ft. Date _____

Driller/Firm Layne

Drill Rig Type AP-1000

Date Installed 2-3-01

Drill Crew Perry

Well No. PC-104

Kerr-McGee
Hydrologist Ed Krish

SOIL BORING LOG KM-5655-B

| KERR-McGEE CORPORATION Hydrology Dept. - S&EA Division | | KM SUBSIDIARY KMC LLC | | LOCATION HENDERSON | | BORING NUMBER PC 116 R | | | |
|---|--|--------------------------|---------------------------|-----------------------|-----------|---------------------------|------|-------|-------------------------------|
| DEPTH IN FEET | LITHOLOGIC DESCRIPTION | GRAPHIC LOG | UNIFIED SOIL FIELD CLASS. | BLOWS PER 6' | PID (ppm) | SOIL SAMPLE | | | REMARKS OR FIELD OBSERVATIONS |
| | | | | | | NO. | TYPE | DEPTH | |
| 5 | 0-10 GRAVEL, sdy and SAND, gravelly - interbedded. Minor thin silty layers. Brn. 50-80% gran → 2" peb. 10-30% silt in sdy matrix 20-50% vf-vc, SA sd. | | GW/SW | | | | | | damp @ 1' wet 2-18' |
| 15 | 10'-18' SAND, silty brn, vf-c g, SA 10-30% silt in matrix locally com. sd-size caliche nodules | | SM | | | | | | |
| 20 | 18-20 SILT, sdy, gry grn, com caliche nods, 20-30% vf-f sd | | ML | | | | | | damp |
| 27 | 20-27 SAND, silty, lt. brn. vf-m g w/ minor c-vc. 20-30% silt in matrix | | SM | | | | | | WTR @ 20' |
| 35 | 27-49 GRAVEL, sdy w/ minor gravelly sand and silty sand. pale brn. (Series of fining-up seq.) 70% volc + ls. granules → cobbles. 20-30% f-vc sd and thin layers w/ 20-30% silt in sdy matrix 27-38 pea gravel | | GP/SM | | | | | | |

| | | | | | |
|--|--|---------------------------|-----------------------|-------------------------------------|----------------|
| EXPLANATION | Water Table (24 Hour) | GRAPHIC LOG LEGEND | | DATE DRILLED 7-25-01 | PAGE 1 of 2 |
| | Water Table (Time of Boring) | CLAY | DEBRIS FILL | DRILLING METHOD PERCUSSION | |
| | PID Photoionization Detection (ppm) | SILT | HIGHLY ORGANIC (PEAT) | DRILLED BY LAYNE | |
| | Identifies Sample by Number | SAND | SANDY CLAY | LOGGED BY ED KRISH | |
| | Sample Collection Method | GRAVEL | CLAYEY SAND | EXISTING GRADE ELEVATION (FT. AMSL) | |
| SPLIT BARREL | AUGER | ROCK CORE | SILTY CLAY | LOCATION OR GRID COORDINATES | |
| THIN-WALLED TUBE | CONTINUOUS SAMPLER | NO RECOVERY | CLAYEY SILT | | |
| DEPTH Depth Top and Bottom of Sample | | | | | |
| REC. Actual Length of Recovered Sample in Feet | | | | | |

SOIL BORING LOG KM-5655-B

| KERR-McGEE CORPORATION Hydrology Dept. - S&EA Division | | KM SUBSIDIARY KMC LLC | | LOCATION HENDERSON, NV | | BORING NUMBER PC 116R | | | | |
|---|---|--------------------------|---------------------------|---------------------------|-----------|--------------------------|------|-------|------|-------------------------------|
| DEPTH IN FEET | LITHOLOGIC DESCRIPTION | GRAPHIC LOG | UNIFIED SOIL FIELD CLASS. | BLOWS PER 6' | PID (ppm) | SOIL SAMPLE | | | | REMARKS OR FIELD OBSERVATIONS |
| | | | | | | NO. | TYPE | DEPTH | REC. | |
| 45 49 | 38'-49' com. cobbles to 6" | | GP / GM | | | | | | | |
| 49 58 | 49-58 CLAY & silty clay, w/ root traces & sm. gyp x fols. greenish and blue green | | CL | | | | | | | MC @ 49' damp |
| 58 | TD 58' | | | | | | | | | |

| | | | | |
|-------------|--|---|-------------------------------------|----------------|
| EXPLANATION | Water Table (24 Hour) | GRAPHIC LOG LEGEND CLAY SILT SAND GRAVEL SILTY CLAY CLAYEY SILT DEBRIS FILL HIGHLY ORGANIC (PEAT) SANDY CLAY CLAYEY SAND | DATE DRILLED 7-25-01 | PAGE 2 of 2 |
| | Water Table (Time of Boring) | | DRILLING METHOD PERCUSSION | |
| | PID NO. Photoionization Detection (ppm) TYPE Identifies Sample by Number | | DRILLED BY LAYNE | |
| | SPLIT-BARREL AUGER ROCK CORE | | LOGGED BY Ed KRISH | |
| | THIN-WALLED TUBE CONTINUOUS SAMPLER NO RECOVERY | | EXISTING GRADE ELEVATION (FT. AMSL) | |
| | DEPTH Depth Top and Bottom of Sample REC. Actual Length of Recovered Sample in Feet | | LOCATION OR GRID COORDINATES | |

KERR-McGEE CORPORATION HYDROLOGY DEPARTMENT MONITORING WELL INSTALLATION DIAGRAM

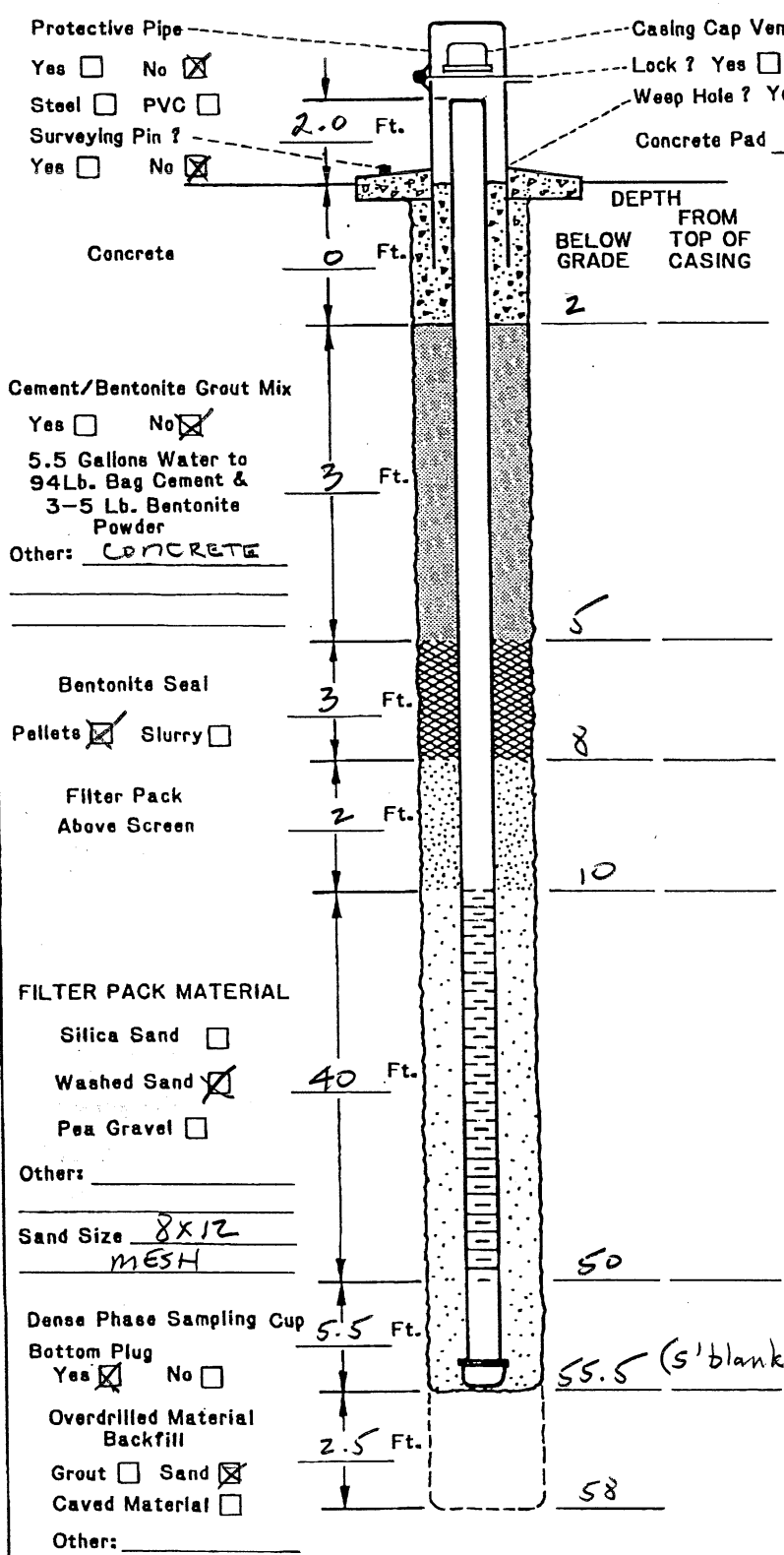

DRILLING INFORMATION:

- Borehole Diameter = 1 3/4 Inches.
- Were Drilling Additives Used? Yes No
 Revert Bentonite Water
 Solid Auger Hollow Stem Auger
- Was Outer Steel Casing Used? Yes No
 Depth = _____ to _____ Feet.
- Borehole Diameter for Outer Casing _____ Inches.

WELL CONSTRUCTION INFORMATION:

- Type of Casing: PVC Galvanized Teflon
 Stainless Other _____
- Type of Casing Joints: Screw-Couple Glue-Couple Other _____
- Type of Well Screen: PVC Galvanized
 Stainless Teflon Other _____
- Diameter of Casing and Well Screen:
 Casing 8 Inches, Screen 8 Inches.
- Slot Size of Screens: 0.040
- Type of Screen Perforation: Factory Slotted
 Hack saw Drilled Other V-WIRE
- Installed Protector Pipe w/Locks: Yes No

WELL DEVELOPMENT INFORMATION:

- How was Well Developed? Bailing Pumping
 Air Surging (Air or Nitrogen) Other SURGE BLOCK
- Time Spent on Well Development? _____ 1 3/2 Minutes/Hours
- Approximate Water Volume Removed? 2000 Gallons
- Water Clarity Before-Development? Clear
 Turbid Opaque
- Water Clarity After Development? Clear
 Turbid Opaque
- Did Water have Odor? Yes No
 If Yes, Describe _____
- Did Water have any Color? Yes No
 If Yes, Describe _____

WATER LEVEL INFORMATION:
 Water Level Summary (From Top of Casing)

During Drilling _____ Ft. Date _____
 Before Development _____ Ft. Date _____
 After Development 4.20 Ft. Date 7-27-01

Driller/Firm LAYNE Drill Rig Type AP 1000 Date Installed 7-26-01
 Drill Crew P. HORMAN Well No. PC116R Kerr-McGee Hydrologist ED KRISH

SOIL BORING LOG KM-5655-A

| KERR-McGEE CORPORATION Hydrology Dept. Engineering Services | | KM SUBSIDIARY KMC LLC | | LOCATION HENDERSON, NV | | BORING NUMBER PC 123 | | | | | |
|--|--|--------------------------|---------------------------|---------------------------|-----------|-------------------------|------|-------|------|-------------------------------|------------|
| DEPTH IN FEET | LITHOLOGIC DESCRIPTION | GRAPHIC LOG | UNIFIED SOIL FIELD CLASS. | BLOWS PER FOOT | PID (ppm) | SOIL SAMPLE | | | | REMARKS OR FIELD OBSERVATIONS | |
| | | | | | | NO. | TYPE | DEPTH | REC. | | |
| 0-1 | Pavement & fill | | | | | | | | | | |
| 1-8 | GRAVEL, silty, brn, 65% void pebbles (SR) to 1-3" w/ 25% vf-vc sd. and 10% silt. | | GW/GM | | | | | | | | |
| 8-12 | SAND, gravelly, brn, 70% vf-vc, SA-SR sd w/ 30% 1/4"-1/2" pea gravel | | SW | | | | | | | | |
| 12-22 | GRAVEL, silty, brn, 70% void pebbles, SR, to 1/2-1" w/ 20% vf-vc, SA-SR sd. and 10% silt | | GW/GM | | | | | | | | Damp @ 17' |
| 22-27 | SAND, gravelly, 70% vf-vc sd, brn, w/ 20% 1/2" pea gravel & 10% silt | | SW/SM | | | | | | | | WET @ 22' |
| 27-33 | GRAVEL, silty, brn w/ mod. hard calcified matrix. 70% gravel to 1-3" w/ 30% sd. | | GW | | | | | | | | |
| 33-35 | mod. calcified CLAY, silty, grn | | CL | | | | | | | | MC @ 33' |
| 35.5 | TD 35.5 | | | | | | | | | | |

EXPLANATION

- Water Table (24 Hour)
- Water Table (Time of Boring)
- PID
NO.
TYPE
- Photoionization Detection (ppm)
- Identifies Sample by Number
- Sample Collection Method
- SPLIT-BARREL
- AUGER
- ROCK CORE
- THIN-WALLED TUBE
- CONTINUOUS SAMPLER
- NO RECOVERY

DEPTH Depth Top and Bottom of Sample
REC. Actual Length of Recovered Sample in Feet

GRAPHIC LOG LEGEND

- CLAY
- SILT
- SAND
- GRAVEL
- SILTY CLAY
- CLAYEY SILT
- DEBRIS FILL
- HIGHLY ORGANIC (PEAT)
- SANDY CLAY
- CLAYEY SAND

DATE DRILLED
3-9-04

PAGE
1 of 1

DRILLING METHOD
HSA

DRILLED BY
WDC

LOGGED BY
ED KRISH

EXISTING GRADE ELEVATION (FT. AMSL)

LOCATION OR GRID COORDINATES

KERR-McGEE CORPORATION HYDROLOGY DEPARTMENT MONITORING WELL INSTALLATION DIAGRAM

*Flush
Mount*

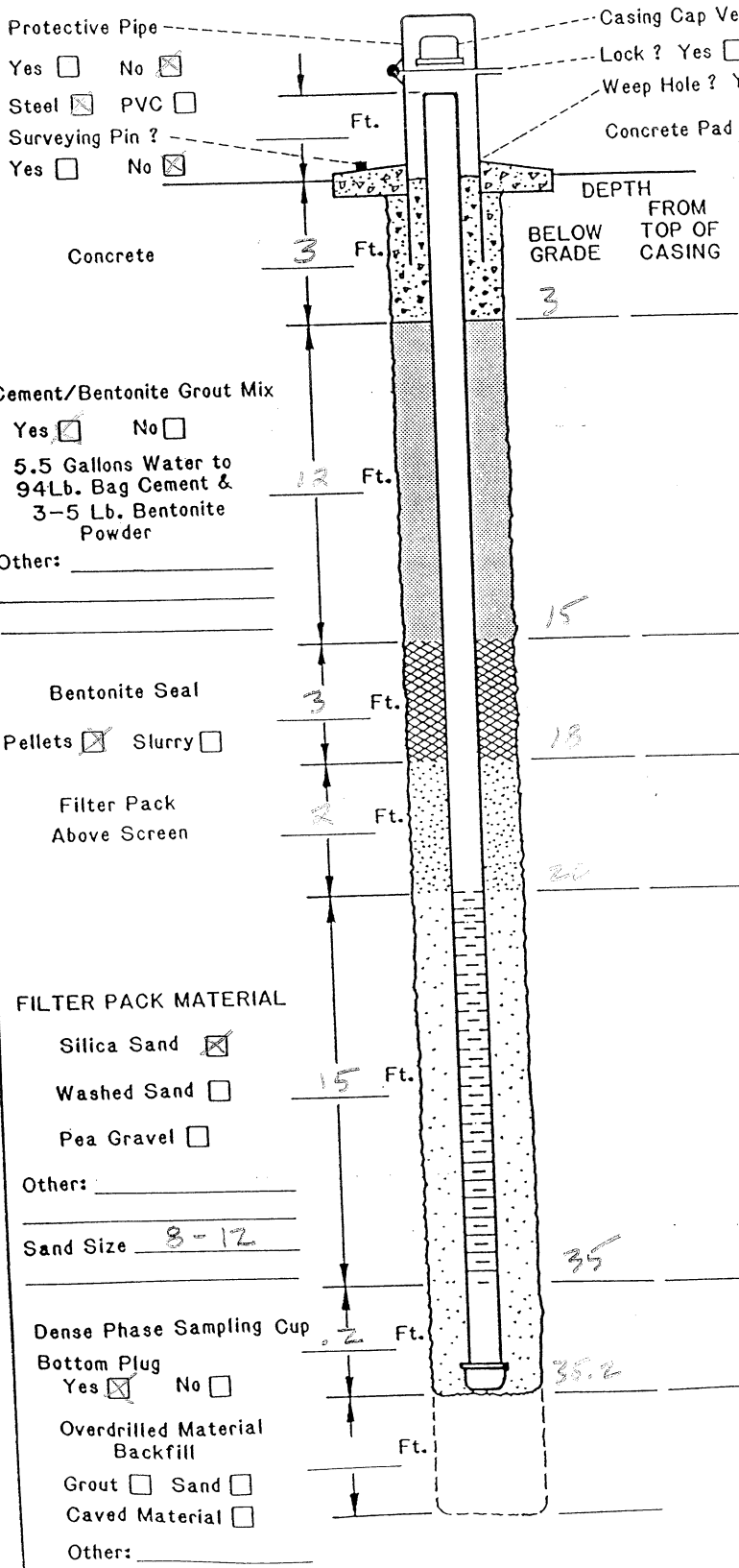

Casing Cap Vent? Yes No
 Lock? Yes No
 Weep Hole? Yes No
 Concrete Pad _____ Ft. x _____ Ft. x _____ Inches

Protective Pipe
 Yes No
 Steel PVC
 Surveying Pin?
 Yes No

DEPTH
 FROM
 TOP OF
 CASING
 BELOW
 GRADE
 3

DRILLING INFORMATION:

- Borehole Diameter = 8 Inches.
- Were Drilling Additives Used? Yes No
 Revert Bentonite Water
 Solid Auger Hollow Stem Auger
- Was Outer Steel Casing Used? Yes No
 Depth = _____ to _____ Feet.
- Borehole Diameter for Outer Casing _____ Inches.

Cement/Bentonite Grout Mix
 Yes No
 5.5 Gallons Water to
 94Lb. Bag Cement &
 3-5 Lb. Bentonite
 Powder
 Other: _____

WELL CONSTRUCTION INFORMATION:

- Type of Casing: PVC Galvanized Teflon
 Stainless Other _____
- Type of Casing Joints: Screw-Couple Glue-Couple Other _____
- Type of Well Screen: PVC Galvanized
 Stainless Teflon Other _____
- Diameter of Casing and Well Screens:
 Casing 2 Inches, Screen 2 Inches.
- Slot Size of Screens: 0.020
- Type of Screen Perforation: Factory Slotted
 Hacksaw Drilled Other _____
- Installed Protector Pipe w/Lock: Yes No

Bentonite Seal
 Pellets Slurry
 Filter Pack
 Above Screen

WELL DEVELOPMENT INFORMATION:

- How was Well Developed? Bailing Pumping
 Air Surging (Air or Nitrogen) Other SURGE
BLACK/AIR LIFT
- Time Spent on Well Development?
60 Minutes/Hours
- Approximate Water Volume Removed? _____ Gallons
- Water Clarity Before Development? Clear
 Turbid Opaque
- Water Clarity After Development? Clear
 Turbid Opaque
- Did Water have Odor? Yes No
 If Yes, Describe _____
- Did Water have any Color? Yes No
 If Yes, Describe _____

FILTER PACK MATERIAL
 Silica Sand
 Washed Sand
 Pea Gravel
 Other: _____
 Sand Size 8-12

WATER LEVEL INFORMATION:

Water Level Summary (From Top of Casing)
 During Drilling 22.3 Ft. Date 3-10-04
 Before Development 22.2 Ft. Date 3-9-04
 After Development _____ Ft. Date 3-10-04

Driller/Firm Garrett Drill Rig Type CMC 25 Date Installed _____
 Drill Crew _____ Well No. PC 123 Kerr-McGee Hydrologist _____

| | |
|-----------------------------------|--|
| <i>Client:</i> | Tronox LLC |
| <i>Project Number:</i> | 04020-023-160 |
| <i>Site Description/Location:</i> | East Side of Athens Road Well Field, Henderson, NV |
| <i>Coordinates:</i> | 26728191.37 N 829517.89 E <i>Elevation:</i> 1615.08 FT |
| <i>Drilling Method:</i> | Sonic with continuous coring |
| <i>Sample Type(s):</i> | Split Spoon and Core <i>Boring Diameter:</i> 8 In. |

| | | | | | | | |
|-----------------------------|-------------------------------|-------------------|----------|----------------------------|------------------|-------------------------|-----------------|
| <i>Weather:</i> | NA | <i>Logged By:</i> | E. Krish | <i>Date/Time Started:</i> | 12/18/2008 11:30 | <i>Depth of Boring:</i> | 38 ft. |
| <i>Drilling Contractor:</i> | Boart Longyear / D. Cervantez | <i>Backfill:</i> | NA | <i>Date/Time Finished:</i> | 12/18/2007 15:00 | <i>Water Level:</i> | Not Encountered |

| DEPTH (ft) | Sample ID | Sample Depth (ft) | Blows per 6" | Recovery (ft) | Headspace (ppm) | USCS | Graphic Log | MATERIAL IDENTIFICATION, color, description of fine grained material (silt and clay) description of coarse grained material (sand and gravel), structural or mineralogical features, density or stiffness, moisture content, odors or staining. | Well Diagram |
|------------|-----------|-------------------|--------------|---------------|-----------------|-------|-------------|--|---|
| 5 | | | | | | SP-SM | | ALLUVIUM: GRAVELLY SAND, light brown (5YR 5/4), 10% silt, 35% fine grained gravel to 3/4" with minor 1-3" from 6-9", 55% very fine to very coarse grained subangular to subrounded sand, moderate calcareous coatings. | <ul style="list-style-type: none"> Flush Mount 2" Sch. 40 PVC Riser Cement (94%) and Bentonite (6%) Slurry Bentonite Seal |
| 15 | | | | | | GP-GM | | <p>SANDY GRAVEL, light brown (5YR 6/4), 10% silt, 40% very fine to very coarse grained subangular to subrounded sand, 50% fine grained gravel to 3/4" with minor 1-3" ,</p> <p>SANDY GRAVEL, at 17.5 feet bgs cobbles to 6".</p> <p>SANDY GRAVEL, caliche zone from 19-19.5 feet bgs.</p> <p>SANDY GRAVEL, caliche zone from 22.5-23 feet bgs.</p> | <ul style="list-style-type: none"> Sand Pack (#2-12) |
| 30 | | | | | | SM | | <p>SANDY GRAVEL, groundwater encountered at 32 feet bgs.</p> <p>SILTY GRAVELLY SAND, dark yellowish brown (10YR 4/2), locally up to 25% silt, 35% fine grained angular to subrounded volcanic pea gravel, up to 40% very fine to very coarse grained subangular to subrounded sand, alternating silty and clean sand.</p> | <ul style="list-style-type: none"> Well Screen (2" Sch. 40 PVC, 0.01" Slot) |
| 35 | | | | | | GP-GM | | <p>SANDY SILTY GRAVEL, brownish gray, very hard calichification, 20-30% very fine to coarse grained sand in matrix, 10-20% silt.</p> <p>SANDY SILTY GRAVEL, from 32.5-33 feet bgs very silty-40%.</p> | |

Notes:

Client: Tronox LLC
Project Number: 04020-023-160
Site Description/Location: East Side of Athens Road Well Field, Henderson, NV
Coordinates: 26728191.37 N 829517.89 E *Elevation:* 1615.08 FT
Drilling Method: Sonic with continuous coring
Sample Type(s): Split Spoon and Core *Boring Diameter:* 8 In.

Well No. PC-136

Sheet: 2 of 2
Monitoring Well Installed: Yes
Screened Interval: 17.7-37.7 ft.

Weather: NA *Logged By:* E. Krish *Date/Time Started:* 12/18/2008 11:30 *Depth of Boring:* 38 ft.
Drilling Contractor: Boart Longyear / D. Cervantez *Backfill:* NA *Date/Time Finished:* 12/18/2007 15:00 *Water Level:* Not Encountered

| DEPTH (ft) | Sample ID | Sample Depth (ft) | Blows per 6" | Recovery (ft) | Headspace (ppm) | USCS | Graphic Log | MATERIAL IDENTIFICATION, color, description of fine grained material (silt and clay) description of coarse grained material (sand and gravel), structural or mineralogical features, density or stiffness, moisture content, odors or staining. | Well Diagram |
|------------|-----------|-------------------|--------------|---------------|-----------------|-------|-------------|---|--------------|
| | | | | | | GP-GM | | SANDY SILTY GRAVEL, brownish gray, very hard calcification, 20-30% very fine to coarse grained sand in matrix, 10-20% silt. (continued) | |
| | | | | | | CL | | MUDDY CREEK FORMATION: CLAY, light greenish gray (10Y 7/1). | |

Total Depth = 38 feet.
 Boring Terminated
 Target depth achieved

Notes:

| | |
|-----------------------------------|--|
| <i>Client:</i> | Tronox LLC |
| <i>Project Number:</i> | 04020-023-160 |
| <i>Site Description/Location:</i> | East Side of Athens Road Well Field, Henderson, NV |
| <i>Coordinates:</i> | 26728198.98 N 829517.57 E <i>Elevation:</i> 1614.83 FT |
| <i>Drilling Method:</i> | Sonic with continuous coring |
| <i>Sample Type(s):</i> | Split Spoon and Core <i>Boring Diameter:</i> 8 In. |

| | |
|-----------------------------------|---------------|
| <i>Sheet:</i> | 1 of 2 |
| <i>Monitoring Well Installed:</i> | Yes |
| <i>Screened Interval:</i> | 59.7-69.7 ft. |

| | | | | | | | |
|-----------------------------|-------------------------------|-------------------|----------|----------------------------|------------------|-------------------------|--------|
| <i>Weather:</i> | NA | <i>Logged By:</i> | E. Krish | <i>Date/Time Started:</i> | 12/17/2007 14:15 | <i>Depth of Boring:</i> | 70 ft. |
| <i>Drilling Contractor:</i> | Boart Longyear / D. Cervantez | <i>Backfill:</i> | NA | <i>Date/Time Finished:</i> | 12/17/2007 17:30 | <i>Water Level:</i> | 28 ft. |

| DEPTH (ft) | Sample ID | Sample Depth (ft) | Blows per 6" | Recovery (ft) | Headspace (ppm) | USCS | Graphic Log | MATERIAL IDENTIFICATION, color, description of fine grained material (silt and clay) description of coarse grained material (sand and gravel), structural or mineralogical features, density or stiffness, moisture content, odors or staining. | Well Diagram |
|------------|-----------|-------------------|--------------|---------------|-----------------|-------|-------------|--|--------------|
| 5 | | | | | | SP-SM | | ALLUVIUM: GRAVELLY SAND, light brown (5YR 6/4), 10% silt, 70% very fine to very coarse grained, subangular to subrounded sand, 20% fine grained volcanic pea gravel, subangular to subrounded to 3/4" with minor 1-2", moderately soft calcareous grain coatings. | |
| 10 | | | | | | | | | |
| 15 | | | | | | | | | |
| 20 | | | | | | GP-GM | | SANDY GRAVEL, light brown (5YR 6/4), 10% silt, 30% very fine to very coarse grained subangular to subrounded sand, 60% fine, angular to subrounded, pea gravel to 1/4", moderate calcareous coatings. | |
| 25 | | | | | | | | -groundwater encountered at 21 feet bgs. | |
| 30 | | | | | | SP | | GRAVELLY SAND, moderate brown (5YR 4/2), 5% silt, 15% fine grained angular to subrounded, volcanic pea gravel to 3/8", 80% very fine to very coarse grained, subangular to subround sand | |
| 35 | | | | | | GM | | SANDY SILTY GRAVEL, very pale orange (10YR 8/2), 20% silt, 30% very fine to very coarse grained subangular to subrounded sand, 50% fine grained angular to subangular pea gravel to 3/8" with minor 1". | |
| | | | | | | | | -hard calchified zone from 34-36 feet bgs. | |

Notes:

| | |
|-----------------------------------|--|
| <i>Client:</i> | Tronox LLC |
| <i>Project Number:</i> | 04020-023-160 |
| <i>Site Description/Location:</i> | East Side of Athens Road Well Field, Henderson, NV |
| <i>Coordinates:</i> | 26728198.98 N 829517.57 E <i>Elevation:</i> 1614.83 FT |
| <i>Drilling Method:</i> | Sonic with continuous coring |
| <i>Sample Type(s):</i> | Split Spoon and Core <i>Boring Diameter:</i> 8 In. |

| | |
|-----------------------------------|---------------|
| <i>Sheet:</i> | 2 of 2 |
| <i>Monitoring Well Installed:</i> | Yes |
| <i>Screened Interval:</i> | 59.7-69.7 ft. |

| | | | | | | | |
|-----------------------------|-------------------------------|-------------------|----------|----------------------------|------------------|-------------------------|--------|
| <i>Weather:</i> | NA | <i>Logged By:</i> | E. Krish | <i>Date/Time Started:</i> | 12/17/2007 14:15 | <i>Depth of Boring:</i> | 70 ft. |
| <i>Drilling Contractor:</i> | Boart Longyear / D. Cervantez | <i>Backfill:</i> | NA | <i>Date/Time Finished:</i> | 12/17/2007 17:30 | <i>Water Level:</i> | 28 ft. |

| DEPTH (ft) | Sample ID | Sample Depth (ft) | Blows per 6" | Recovery (ft) | Headspace (ppm) | USCS | Graphic Log | MATERIAL IDENTIFICATION, color, description of fine grained material (silt and clay) description of coarse grained material (sand and gravel), structural or mineralogical features, density or stiffness, moisture content, odors or staining. | Well Diagram |
|------------|-----------|-------------------|--------------|---------------|-----------------|-------|-------------|--|---|
| 40 | | | | | | GM | | | |
| 45 | | | | | | CL-ML | | MUDDY CREEK FORMATION: INTERBEDDED SILTY CLAY AND SANDY CLAYEY SILT, yellow gray (5Y8/1) to medium gray (N5), predominately low plastic fines with up to 20% very fine grained sand present -light greenish gray (5GY 8/1) from 38 to 40 feet bgs. -yellowish gray (5Y 7/2) from 40 to 49 feet bgs. -mottled dark yellowish green (5Y 6/2) to dark gray (5Y 9/1) from 49 to 50.5 feet bgs. | |
| 50 | | | | | | CL-ML | | SANDY AND SILTY CLAY, medium gray (N5) and light gray (N7) 25% silt, 15% very fine grained sand. | |
| 55 | | | | | | ML | | SANDY SILT, dusky yellow (5Y 6/4) , 20% very fine grained sand. | Bentonite Seal |
| 60 | | | | 1.5 | | ML | | SANDY SILT, pale olive (10YR 6/2) | Sand Pack #2-12 |
| 65 | | | | | | SM | | SILTY SAND, medium blue gray (5B 5/1), 30% silt, 70% very fine grained sand. | |
| | | | | | | CL | | SILTY CLAY AND CLAYEY SILT, greenish gray (5G 6/1), disseminated very fine grained marcasite. | |
| | | | | | | SM | | SILTY AND CLAYEY SAND, greenish gray (5G 6/1), 40% silty clay, 60% very fine grained sand, disseminated very fine grained marcasite. | |
| | | | | | | CL | | CLAY WITH GYPSUM CRYSTALS, dark yellowish brown (10YR 4/2), abundant gypsum crystals 3/8 to 11/2". | Well Screen (2" Sch. 40 PVC 0.01" Slot) |
| 70 | | | | | | CL | | INTERBEDDED SILTY CLAY AND CLAYEY SILT, moderate brown (10YR 5/4), no crystals. | |

Notes:

Total Depth = 70 feet.
Boring Terminated
Target depth achieved

SOIL BORING LOG KM-5655-B

| KERR-McGEE CORPORATION Hydrology Dept. - S&EA Division | | KM SUBSIDIARY KMC LLC | | LOCATION HENDERSON, NJ | | BORING NUMBER PC-1 | | | |
|--|---|--------------------------|---------------------------|---------------------------|-----------|-----------------------|-------------|-------|------------------------------------|
| DEPTH IN FEET | LITHOLOGIC DESCRIPTION | GRAPHIC LOG | UNIFIED SOIL FIELD CLASS. | BLOWS PER 6" | PID (ppm) | SOIL SAMPLE | | | REMARKS OR FIELD OBSERVATIONS |
| | | | | | | NO. | TYPE | DEPTH | |
| 5 | FILL: SAND/GRAVEL IN IMPOUNDMENT BERM | | | | | | | | |
| 10 | SAND/SILTY SAND; LT. TAN-BROWN; GRAVEL COMMON; WELL-GRADED; DRY | | SM | | | | | | |
| 15 | SAND AS ABOVE | | GM | | | | | | |
| 20 | CAULIC ZONE @ 17-19' | | | | | | | | |
| 23.5 | SAND AS ABOVE; BELOWWATER MUDST | | | | | | | | |
| 25 | GRAVEL ZONE @ 22' | | | | | | | | |
| 23.5 | | | | 23.79 | | | | | GROUNDWATER SAMPLE COLLECTED @ 28' |
| 31 | SILTY CLAY; RED-BROWN W/ LT. GRAY-GREEN REDUCED ZONES | | CL | | | | | | |
| 32 | MUDDY CREEK | | | 814.48 | 1 | X | 32 33.5' | 1.2' | |
| | TO 32' | | | | | | | | |

| | | | | | |
|--------------------|---|---------------------------------|---------------------------|-------------------------------------|-----------------|
| EXPLANATION | | Water Table (24 Hour) | GRAPHIC LOG LEGEND | DATE DRILLED | PAGE |
| | | Water Table (Time of Boring) | | | 3/23/98 |
| | | Photoionization Detection (ppm) | | | DRILLING METHOD |
| | | Identifies Sample by Number | | | HSA |
| | | Sample Collection Method | | | DRILLED BY |
| | SPLIT-BARREL | | | WEBER DRILLING | |
| | AUGER | | | LOGGED BY | |
| | ROCK CORE | | | T. REED | |
| | THIN-WALLED TUBE | | | EXISTING GRADE ELEVATION (FT. AMSL) | |
| | CONTINUOUS SAMPLER | | | LOCATION OR GRID COORDINATES | |
| | NO RECOVERY | | | | |
| DEPTH | Depth Top and Bottom of Sample | | | | |
| REC. | Actual Length of Recovered Sample in Feet | | | | |

**KERR-McGEE CORPORATION
HYDROLOGY DEPARTMENT
MONITORING WELL INSTALLATION DIAGRAM**

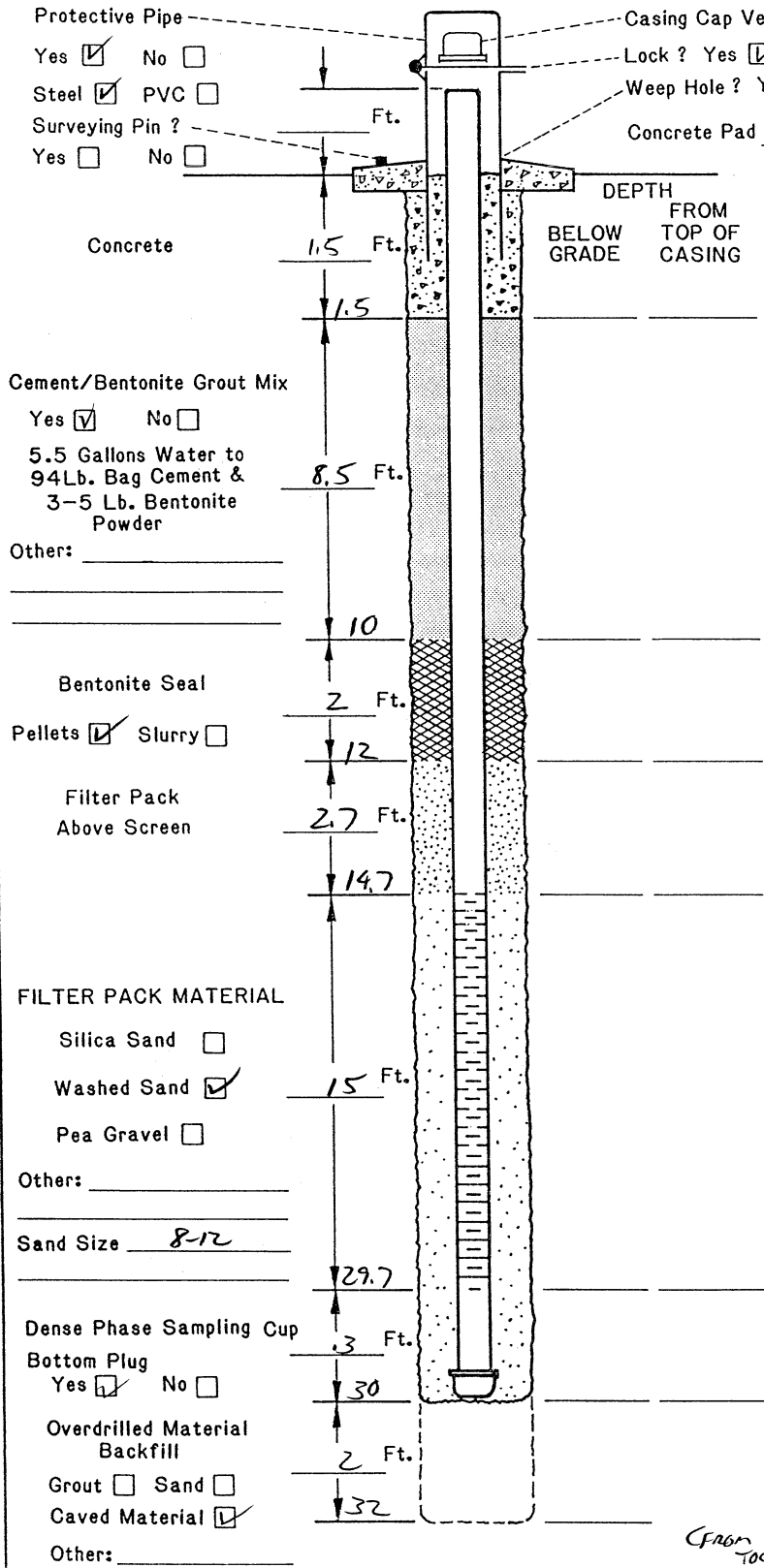

DRILLING INFORMATION:

- Borehole Diameter = 8 Inches.
- Were Drilling Additives Used? Yes No
Revert Bentonite Water
Solid Auger Hollow Stem Auger
- Was Outer Steel Casing Used? Yes No
Depth = _____ to _____ Feet.
- Borehole Diameter for Outer Casing _____ Inches.

WELL CONSTRUCTION INFORMATION:

- Type of Casing: PVC Galvanized Teflon
Stainless Other _____
- Type of Casing Joints: Screw-Couple Glue-Couple Other _____
- Type of Well Screen: PVC Galvanized
Stainless Teflon Other _____
- Diameter of Casing and Well Screen:
Casing 2 Inches, Screen 2 Inches.
- Slot Size of Screen: 10/20
- Type of Screen Perforation: Factory Slotted
Hacksaw Drilled Other _____
- Installed Protector Pipe w/Lock: Yes No

WELL DEVELOPMENT INFORMATION:

- How was Well Developed? Bailing Pumping
Air Surging (Air or Nitrogen) Other _____
- Time Spent on Well Development?
10 / 1 Minutes/Hours
- Approximate Water Volume Removed? 140 Gallons
- Water Clarity Before Development? Clear
Turbid Opaque
- Water Clarity After Development? Clear
Turbid Opaque
- Did Water have Odor? Yes No
If Yes, Describe _____
- Did Water have any Color? Yes No
If Yes, Describe _____

WATER LEVEL INFORMATION:

Water Level Summary (From Top of Casing)

During Drilling 23.5 Ft. Date 3/23/98
Before Development 20.3 Ft. Date 3/24/98
After Development 22.42 Ft. Date 3/25/98

Driller/Firm ROBERTSON/WEBER DRILLING Drill Rig Type MOBILE B-61 Date Installed 3/24/98
Drill Crew ROBERTSON/JOHNSON/RIVERA Well No. PC-1 Kerr-McGee Hydrologist T. REED

SOIL BORING LOG KM-5655-B

| | | | |
|--|--------------------------------|----------------------------------|------------------------------|
| KERR-McGEE CORPORATION Hydrology Dept. - S&EA Division | KM SUBSIDIARY <i>KMCLLC</i> | LOCATION <i>HENDERSON, NV</i> | BORING NUMBER <i>PC-4</i> |
|--|--------------------------------|----------------------------------|------------------------------|

| DEPTH IN FEET | LITHOLOGIC DESCRIPTION | GRAPHIC LOG | UNIFIED SOIL FIELD CLASS. | BLOWS PER 6" | PID (ppm) | SOIL SAMPLE | | | REMARKS OR FIELD OBSERVATIONS |
|---------------|---|-------------|---------------------------|--------------|-----------|-------------|------|-------|-------------------------------|
| | | | | | | NO. | TYPE | DEPTH | |
| 5 | FILL: SAND AND GRAVEL IN IMPOUNDMENT BERM | | | | | | | | |
| 10 | SAND / SILTY SAND; GRAVEL COMMON TO 100; LT. TAN-BROWN; DRY TO SLI. MOIST; WELL-GRADED GRAVEL @ 11-13.5' | | | | | | | | |
| 15 | SAND AS ABOVE | | SM-GM | | | | | | |
| 22 | | | | | | | | | |
| 25 | GRAVEL @ 25-27' | | | | | | | | |
| 30 | SAND AS ABOVE; SATURATED | | | | | | | | |
| 35 | GRAVEL @ 38-40' | | SM-GM | | | | | | |
| 40 | | | | | | | | | |

| | | | | | | |
|--|------------------|-------------------------------------|---------------------------|---|--------------------------------|-----------------------|
| EXPLANATION | | Water Table (24 Hour) | GRAPHIC LOG LEGEND | | DATE DRILLED <i>3/24/98</i> | PAGE <i>1 of 2</i> |
| | | Water Table (Time of Boring) | | CLAY | | DEBRIS FILL |
| | | PID Photoionization Detection (ppm) | | SILT | | HIGHLY ORGANIC (PEAT) |
| | | Identifies Sample by Number | | SAND | | SANDY CLAY |
| | | Sample Collection Method | | GRAVEL | | CLAYEY SAND |
| | SPLIT-BARREL | | AUGER | | SILTY CLAY | |
| | THIN-WALLED TUBE | | CONTINUOUS SAMPLER | | | |
| | ROCK CORE | | NO RECOVERY | | | |
| DEPTH Depth Top and Bottom of Sample | | | | DRILLED BY <i>HSA</i> | | |
| REC. Actual Length of Recovered Sample in Feet | | | | LOGGED BY <i>WEBER DRILLING</i> | | |
| | | | | EXISTING GRADE ELEVATION (FT. AMSL) <i>T. REED</i> | | |
| | | | | LOCATION OR GRID COORDINATES | | |

SOIL BORING LOG KM-5655-B

| | | | | |
|--|--|--------------------------------|----------------------------------|--------------------------------------|
| KERR-McGEE CORPORATION Hydrology Dept. - S&EA Division | | KM SUBSIDIARY KMCLLC | LOCATION HENDERSON, NV | BORING NUMBER PC-4 (CONT.) |
|--|--|--------------------------------|----------------------------------|--------------------------------------|

| DEPTH IN FEET | LITHOLOGIC DESCRIPTION | GRAPHIC LOG | UNIFIED SOIL FIELD CLASS. | BLOWS PER 6" | PID (ppm) | SOIL SAMPLE | | | REMARKS OR FIELD OBSERVATIONS | |
|---------------------|-----------------------------------|---|------------------------------------|--------------------|--------------|-------------|------|------------|-----------------------------------|------|
| | | | | | | NO. | TYPE | DEPTH | | REC. |
| 40 | GRAVEL @ 41.5-42.5' | 0.0 0.1 0.2 0.3 0.4 0.5 0.6 0.7 0.8 0.9 1.0 | SM- GM | | | | | | GROUNDWATER SAMPLE TAKEN @ 42' | |
| 43.5 | SILTY CLAY; LT. GRAY-GREEN; SLI. | 1.1 1.2 1.3 1.4 1.5 1.6 1.7 1.8 1.9 2.0 | CL | | | | | | | |
| 45 | PLASTIC MUDDY CREEK TO 45' | 2.1 2.2 2.3 2.4 2.5 2.6 2.7 2.8 2.9 3.0 | | | | | | | | |
| | | | | 1734 52 | | 1 | X | 45 46.5 | 1.4' | |

| | | | | | |
|-------------|--|---------------------------|--------------------------|-------------------------------------|-----------------------|
| EXPLANATION | Water Table (24 Hour) | GRAPHIC LOG LEGEND | | DATE DRILLED 3/24/98 | PAGE 2 of 2 |
| | Water Table (Time of Boring) PID NO. TYPE | CLAY | DEBRIS FILL | DRILLING METHOD | |
| | Identifies Sample by Number | SILT | HIGHLY ORGANIC (PEAT) | DRILLED BY HSA | |
| | Sample Collection Method | SAND | SANDY CLAY | LOGGED BY WEBER DRILLING | |
| | SPLIT- BARREL | AUGER | ROCK CORE | EXISTING GRADE ELEVATION (FT. AMSL) | |
| | THIN- WALLED TUBE | CONTINUOUS SAMPLER | NO RECOVERY | LOCATION OR GRID COORDINATES | |
| DEPTH | Depth Top and Bottom of Sample | | CLAYEY SAND | T. REED | |
| REC. | Actual Length of Recovered Sample in Feet | | SILTY CLAY | | |
| | | | CLAYEY SILT | | |

**KERR-McGEE CORPORATION
HYDROLOGY DEPARTMENT
MONITORING WELL INSTALLATION DIAGRAM**

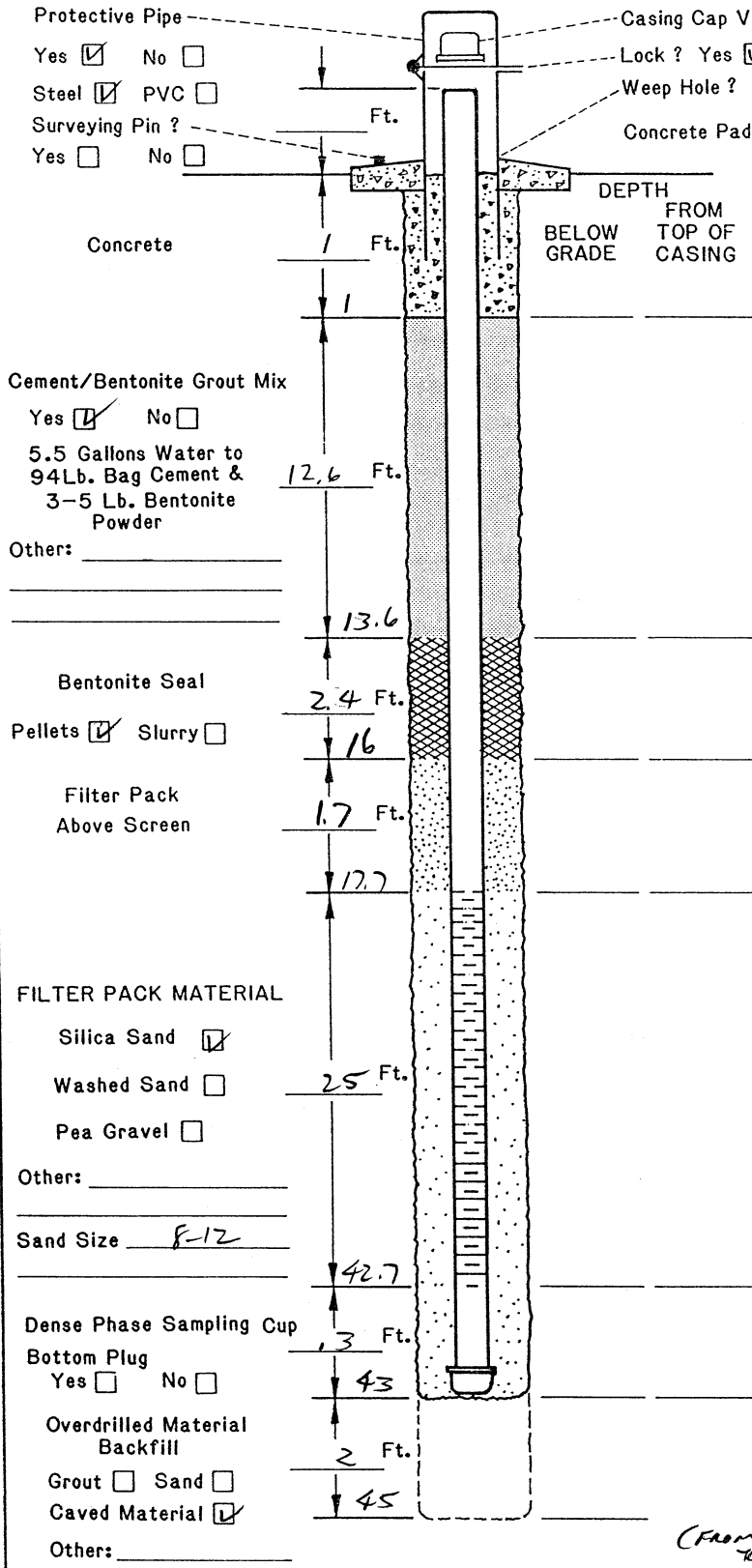

Casing Cap Vent? Yes No
 Lock? Yes No
 Weep Hole? Yes No
 Concrete Pad _____ Ft. x _____ Ft. x _____ Inches

- DRILLING INFORMATION:**
- Borehole Diameter = 8 Inches.
 - Were Drilling Additives Used? Yes No
 Revert Bentonite Water
 Solid Auger Hollow Stem Auger
 - Was Outer Steel Casing Used? Yes No
 Depth = _____ to _____ Feet.
 - Borehole Diameter for Outer Casing _____ Inches.

- WELL CONSTRUCTION INFORMATION:**
- Type of Casing: PVC Galvanized Teflon
 Stainless Other _____
 - Type of Casing Joints: Screw-Couple Glue-Couple Other _____
 - Type of Well Screens: PVC Galvanized
 Stainless Teflon Other _____
 - Diameter of Casing and Well Screens:
 Casing 2 Inches, Screen 2 Inches.
 - Slot Size of Screen: .020
 - Type of Screen Perforation: Factory Slotted
 Hacksaw Drilled Other _____
 - Installed Protector Pipe w/Lock: Yes No

- WELL DEVELOPMENT INFORMATION:**
- How was Well Developed? Bailing Pumping
 Air Surging (Air or Nitrogen) Other _____
 - Time Spent on Well Development? 45 / _____ Minutes/Hours
 - Approximate Water Volume Removed? 50 Gallons
 - Water Clarity Before Development? Clear
 Turbid Opaque
 - Water Clarity After Development? Clear
 Turbid Opaque
 - Did Water have Odr? Yes No
 If Yes, Describe _____
 - Did Water have any Color? Yes No
 If Yes, Describe _____

WATER LEVEL INFORMATION:
 Water Level Summary (From Top of Casing)
 During Drilling 22' Ft. Date 3/24/98
 Before Development _____ Ft. Date _____
 After Development 23.65' Ft. Date 3/25/98

Driller/Firm L. ROBERTSON / WEBER DRILL Drill Rig Type MOBILE B-61 Date Installed 3/24/98
 Drill Crew ROBERTSON / JOHNSON / RIVERA Well No. PC-4 Kerr-McGee Hydrologist T. RAED

Appendix B

Standard Operating Procedures

Standard Operating Procedure B-1: Soil Sampling with Direct-Push or Hollow-Stem Auger Samplers

This standard operating procedure (SOP) is applicable to the collection of representative soil samples using a direct-push or hollow-stem auger sampling technique. The methodologies discussed in this SOP are generic in nature and may be modified in whole or part to meet the handling and analytical requirements of the contaminants of concern, as well as the constraints presented by site conditions and equipment limitations. Modifications of sampling methodologies will be documented in the appropriate field logbook and discussed in reports summarizing field activities and analytical results. For the purposes of this procedure, soils are those mineral and organic materials not submerged in water for an extended period of time sufficient to support aquatic life.

Sample Collection

The primary means for the collection of subsurface soil samples will be a direct-push technique using a Geoprobe® or equivalent driver. Direct-push soil samples will be obtained using a closed-piston soil sampler with a liner (or equivalent sampling system). If needed, a hollow-stem auger sampler may be used to collect soil samples. The sampler will be operated in accordance with the manufacturer's recommended operating procedures for the type of equipment used.

Discrete Soil Sampling Procedures

Soil samples will be collected at predetermined intervals based on specific data needs. Each discrete sample will be described in the field notebook using the Unified Soil Classification System (USCS) as described below. Soil samples that will not become composite samples will be placed directly in the appropriate sample containers using a clean plastic or metal spatula, or by using a clean gloved hand.

Subsamples selected for laboratory analysis will be placed in appropriate sample containers provided by the analytical laboratory, labeled, placed in an iced cooler, and stored in accordance with chain-of-custody requirements specified in the QAPP (Appendix A to the Final (100%) Design Report) until shipment to the laboratory (or laboratories) is arranged. Chain-of-custody records will be completed for all samples according to the methods described in the QAPP (Appendix A to the Final (100%) Design Report).

Discrete samples that will become aliquots of a composite sample will be covered or capped as soon as possible after collection if the compositing process is not completed immediately. Each sample container will be labeled and stored on ice pending the composite process.

Composite Soil Sampling Procedures

Composite samples will be prepared from the discrete samples following collection of the required number of discrete sample specified for the sampling area. Each discrete sample will be removed from the sample container and placed on a clean sheet of aluminum foil. After removing sticks, grass, stones, and other debris, each discrete sample will be separated into quarters – cores will be cut lengthwise into 4 equal portions, while disturbed samples will be homogenized and divided. Three of the four quarters of each sample will then be placed into

one of three individual foil pans. The fourth portion of the discrete sample will be placed in a plastic baggie, labeled, sealed, and stored separately for potential individual analysis.

The compositing process of quartering discrete samples will be repeated for successive discrete samples until each of the three pans contains one quarter of each discrete sample. The contents of each aluminum foil pan will then be thoroughly mixed either by hand or by using an electrical or mechanical mixer. Upon completion of the mixing process, the contents of each individual pan will then be combined into one clean pan and again thoroughly mixed, resulting in one homogeneous sample. The composite soil sample will then be placed in the appropriate sample containers, labeled, and placed on ice pending shipment to the laboratory.

VOC Sample Collection Procedures

Soil samples obtained for laboratory analysis of VOCs will be collected in compliance with SW-846 Method 5035. Each soil sample will be obtained directly from the sampling device (i.e., not homogenized) using an EnCore™ sampler or field preserved using Method 5035 compatible containers. A description of each sampling procedure is as follows:

EnCore Sampler

The EnCore™ sampler is a single use, commercially available device constructed of an inert composite polymer. EnCore™ uses a coring/storage chamber to collect either a 5-gram or 25-gram sample of cohesive soils. It has a press-on cap with a hermetically vapor tight seal and a locking arm mechanism. Three EnCore™ samplers shall be filled at each sample location using the following procedures:

- Place the EnCore™ sampler into the EnCore™ T-Handle tool.
- Push the sampler into the soil sample until the small o-ring on the plunger of the EnCore™ sampler is visible in the T-Handle viewing hole.
- Wipe off any excess soil from the coring body exterior using a clean paper towel.
- Place the cap on the end of the EnCore™ sampler and twist to lock the cap into place.
- Remove the sampler from the T-Handle and lock the plunger by rotating extended plunger rod fully counterclockwise until the plunger wings rest firmly against the plunger tabs.
- Place the label on the sampler and place the sampling into a labeled EnCore™ sampler bag and zip closed.
- Place the filled EnCore™ samplers in a cooler with ice for overnight shipment to the laboratory using standard chain-of-custody procedures. The soil samples must be prepared for analysis or frozen within 48 hours of sample collection.

Field Preservation

The procedures for the field preservation method are as follows:

- Push a one-time use plastic sampling tool such as a Terra Core™ sampler into the soil to be samples to collect an approximately 5-gram sample aliquot.
- Transfer the 5-gram aliquot to laboratory provided, pre-preserved, 40-milliliter vials containing a specific amount of methanol, sodium bisulfate, and/or organic-free water. The

number of vials provided with each preservative will vary by the laboratory performing the analysis. One unpreserved container shall also be filled to allow for laboratory calculation of the sample dry weight.

- Label each sample and place in a cooler with ice for overnight shipment to the laboratory using standard chain-of-custody procedures.

Sample Description and Field Documentation

After samples for chemical and physical analysis have been prepared, a visual soil or lithologic description of each sample will be made according to the USCS, and will be recorded in a bound log notebook. Each sampling location will be photographed, and the approximate location will be placed on a site map and recorded in the field notebook.

Residual soil from the compositing process and stored individual discrete sample portions will be disposed in accordance with the Sampling and Analysis Plan.

Equipment Decontamination

Drilling and support equipment will not come in direct contact with the samples, so cross-contamination of samples is not a concern. However, this equipment will likely come in contact with impacted soil and must therefore be decontaminated prior to moving from one location to another.

The drilling equipment used for soil sampling and monitoring well installation will be cleaned with high-pressure/hot water washing equipment prior to initiating the field investigation. The same procedure will be applied to all drilling equipment between each boring location. The cleaning will occur at a decontamination pad constructed at a suitable location(s) at the site. Water used for cleaning will be obtained from a local potable water source. Equipment subject to these decontamination procedures includes, but is not limited to, the following:

- Direct-push or hollow-stem auger drill rig.
- Direct-push or hollow-stem auger sampler components.

In addition, downhole equipment that comes in direct contact with samples will be decontaminated between each sample interval. This procedure will include washing with a nonphosphate detergent and rinsing with clean potable water.

If required, a piece of sampling equipment that comes in direct contact with soil samples (e.g., split-barrel samplers) will be selected for collection of field equipment blanks. After the equipment has been cleaned, it will be rinsed with DI water. The rinse water will be collected and submitted for analysis of all constituents for which the normal samples collected with the equipment are being analyzed.

Field blanks will be collected at the frequency specified in the QAPP (Appendix A to the Final (100%) Design Report).

Standard Operating Procedure B-2: Low-Flow Groundwater Sampling for Chemical Analysis

1 Purpose and Scope

This standard operating procedure (SOP) describes the procedures to be followed by a Field Geologist/Engineer while collecting groundwater samples using low-flow purging and sampling procedures. The low-flow methodology may alternatively be referred to by names such as “micropurging”, “low-stress purging”, low-impact purging, or “minimal drawdown purging.” This SOP should be used primarily for collection of groundwater samples from permanent wells that have been designed, constructed, and developed for the purpose of monitoring groundwater. The groundwater samples that are collected using this SOP are acceptable for the analysis of environmental contaminants including, but not limited to: volatile organic compounds (VOCs), semi-volatile organic compounds (SVOCs), pesticides and herbicides, polychlorinated biphenyls (PCBs), petroleum hydrocarbons, metals, and other inorganic compounds.

The procedures presented herein are intended to be of general use and may be supplemented by a Work Plan, Sampling and Analysis Plan, Quality Assurance Project Plan, and/or a Health and Safety Plan. Some of these procedures may not be required depending on the specific scope of work being conducted. As the work progresses, and if warranted, appropriate revisions may be made by the Project Manager. Procedures in this protocol may be superseded by applicable regulatory requirements.

2 General Requirements

All personnel performing on-site operations with the potential for exposure to hazardous substances or health hazards are required to be 40-hour trained in accordance with Code of Federal Regulations (CFR) 1910.120 and will meet the personnel training requirements in accordance with 29 CFR 1910.120(e).

The laboratory must be certified by the appropriate regulating agency for the analyses to be performed. If drilling is required as part of the scope of work, permits will be acquired from the appropriate agency, and an underground utility check will be performed before drilling begins. An underground utility check will, at a minimum, consist of contracting with a local utility alert service, if available. Under certain circumstances, including at sites with deeply buried, unknown, or multiple underground utilities, as well as at high risk sites such as oil refineries and heavy industrial facilities, manual utility clearance using hand auger or air knife methods should also be performed.

The activities described in this SOP require the implementation of a site-specific Health and Safety Plan to inform personnel of the hazards associated with this work and to describe the methods that will be employed to mitigate those hazards. The Health and Safety Plan must be prepared and approved by the Project Manager and the local Health and Safety Coordinator prior to initiating field work. A Health and Safety Meeting must be held at the start of each day to reassess any potential hazards associated with that day’s field work.

3 Methods

This SOP has been prepared in accordance with the United States Environmental Protection Agency (USEPA) Standard Operating Procedure for Low-Stress (Low Flow)/Minimal Drawdown

Ground-Water Sample Collection, dated 2002. This guidance document is included as Attachment 3 of the Ground-Water Sampling Guidelines for Superfund and RCRA Project Managers, which may be found via the following internet link:

http://www.epa.gov/swertio1/tsp/download/gw_sampling_guide.pdf

This methodology described herein is also consistent with the California Environmental Agency's (Cal-EPA), Representative Sampling of Groundwater for Hazardous Substances, Guidance Manual for Ground Water Investigations, dated June 2005. This document may be found via the following internet link:

http://www.dtsc.ca.gov/SiteCleanup/upload/SMP_Representative_Sampling_GroundWater.pdf

Unlike traditional purging methods, low-flow purging and sampling does not require the removal of an arbitrary volume of water from a well prior to sampling. Instead, low-flow purging and sampling relies on careful monitoring of water quality indicator parameters to determine when a representative groundwater sample can be collected. The low-flow methodology minimizes the effects on groundwater chemistry caused by the purging process by minimizing drawdown, reducing the amount of water removed from the well, and reducing the amount of turbidity in groundwater samples.

4 Equipment and Materials

A non-exhaustive summary of common supplies and equipment is presented below:

- Health and Safety Plan
- Site information (maps, contact numbers, previous field logs, etc.)
- Electronic water level indicator (Solinst or similar)
- Photoionization Detector (PID) or Flame ionization detector (FID) if VOCs are suspected
- Adjustable-rate sampling pump capable of rates <0.5 liters per minute (bladder pump preferred, e.g., QED Sample Pro)
- Bladders for sample pump
- Sample tubing (Teflon® or Teflon®-lined tubing preferred for sampling organic compounds)
- Multi-parameter meter (e.g. YSI 556 Multi-Parameter Meter) with flow through cell capable of measuring (at a minimum) temperature, pH, specific electrical conductance (SEC), dissolved oxygen (DO), and oxidation-reduction potential (ORP)
- Turbidity meter
- In-line filters (if required, e.g. for dissolved metals)
- Certified-clean sample containers and preservation supplies, sample labels, Ziploc™ bags

- Cooler with ice
- Decontamination supplies (e.g. phosphate-free detergent, distilled water)
- Tool kit with appropriate tools (socket wrench set, pry bar, Dolphin locks/keys)
- Drum(s) to collect purged water and decontamination water
- Drum labels
- Personal Protective Equipment (PPE), typically PPE will consist of:
 - Long-sleeved shirt and long pants
 - Steel-toed boots
 - Hardhat
 - Nitrile gloves
 - Safety glasses with side shields
 - Other as required by Health and Safety Plan
- Field Forms (If the project requires it, a project-specific Field Logbook may substitute for any of the following with the exception of the Chain of Custody)
 - *Field Investigation Daily Log*
 - *Water Level Measurement Log*
 - *Low-Flow Purging and Sampling Log*
 - *Equipment Calibration Log*
 - *Chain-of-Custody*

5 Procedures

The following sections discuss the procedures to follow during low-flow purging and sampling monitoring wells with dedicated or non-dedicated equipment (e.g., bladder pumps with adjustable rate controls). Where applicable and when possible, the purging and sampling techniques should remain consistent from one sampling event to the next.

5.1 Pre-Sampling Activities

1. Sampling should begin at the monitoring well with the least contamination, generally up-gradient or farthest from the site or suspected source. Then proceeding systematically to the monitoring wells with the higher expected groundwater concentrations.
2. All measuring devices and monitoring equipment should be calibrated according to manufacturer's recommendations. Water quality meters must be calibrated daily before use. Equipment calibration details should be recorded in the *Equipment Calibration Log*.
3. Unlock well and/or remove well cap. Record any damage or evidence of pressure (positive or negative) in the well in the *Water Level Measurement Log*. Monitor the headspace at the

top of the well for VOCs with a PID or FID and record findings. If VOCs are present, monitor worker breathing zones during purging and sampling in accordance with the site Health and Safety Plan.

4. Prior to sampling, the depth-to-water in all wells must be measured to obtain the current static water level. Water levels should be measured to the nearest 0.01 feet relative to a reference measuring point on the Top of Casing (TOC) which must be surveyed relative to ground elevation. If there is no marked reference point on the TOC, measure from the North side of the casing. Record depth to groundwater information in the *Water Level Measurement Log*. The same water level measuring device should be used for all wells, if possible, and must be decontaminated between each well.
5. Use existing site information for total depth (TD) of monitoring well and use the information from depth to water to calculate the volume of water in the monitoring well. The TD of wells to be sampled should not be tagged prior to sampling to avoid disturbing sediments at the bottom of the well. If possible, have this information prior to the day of sampling. The TD of wells should be verified after sampling. Record TD and water volume information in the *Low-Flow Purging and Sampling Log*.

5.2 Purging and Sampling

1. If using non-dedicated equipment, place the pump and support equipment at the well head and slowly lower the pump and tubing down into the monitoring well until the location of the pump intake is set at a predetermined location within the screen interval. Where possible, pre-measured tubing should be used to place the pump intake at the same depth as previous sampling events, or at a depth where there is known contamination within the screen interval. If there is no previous information for the well, the pump intake should be placed at the middle (or slightly above the middle) of the screen interval. Record the pump depth in the *Low-Flow Purging and Sampling Log*.
2. Measure depth to water to the nearest 0.01 feet relative to the reference measuring point on the TOC with an electronic water level indicator. Record depth to groundwater information in the *Low-Flow Purging and Sampling Log*. Leave water level indicator in the well.
3. Connect the discharge line from the pump to a flow-through cell that at a minimum measures temperature, pH, SEC, DO, and ORP. Turbidity measurements can be made using a separate turbidity meter. The discharge line from the flow-through cell must be directed to a container to hold purge water collected during purging and sampling of the well.
4. Start pumping the well at a flow rate of between 0.1 and 0.5 liters per minute (L/min) and slowly increase the flow rate. (For new wells or wells with no purging history, start at the lower end of that range.) Check the water level. Maintain a steady flow rate while maintaining a drawdown of less than 0.3 feet. (Zero drawdown is optimal, but infrequently achievable). If drawdown is greater than 0.3 feet, lower the flow rate; 0.3 feet is a goal to help guide with the flow rate adjustment. This goal will be difficult to achieve in some wells due to low hydraulic conductivities and limitations to the lowest flow rate a pump can produce while maintaining steady flow. This goal may be adjusted based on site-specific conditions and personal experience. See the Special Advisory at the end of these

procedures.

5. Measure the discharge rate of the pump with a graduated cylinder and a stopwatch.

Also, measure the water level and record both flow rate and water level on the *Low-Flow Purging and Sampling Log*. Continue purging, monitor and record water level and pump rate every 3 to 5 minutes. Purging rates should be kept at minimal flow to ensure

minimal drawdown in the monitoring well.

6. A minimum of one tubing volume (including the volume of the water in the pump and flow cell) must be purged prior to recording the water quality indicator parameters. After this has been accomplished, monitor and record the water quality indicator parameters every three to five minutes in the *Low-Flow Purging and Sampling Log*. Stable readings of temperature, pH, SEC, DO, turbidity and ORP indicate when a representative sample can be collected. The stabilization criterion is based on three successive readings of the water quality indicator parameters as shown in Table 1. ORP may not always be an appropriate stabilization parameter and will depend on site-specific conditions. However, readings should be recorded because of its value for double-checking oxidizing conditions. The stabilization criterion is based on three successive readings of the water quality indicator parameters as shown in Table 1.

| TABLE 1: Stabilization Criteria for Water Quality Indicator Parameters | |
|---|---|
| Parameter | Stabilization Criteria |
| Temperature | ± 3% of reading (minimum of ±0.2° C) |
| pH | ± 0.1 pH units |
| Specific Electrical Conductance (SEC) | ± 3% S/cm |
| Dissolved Oxygen (DO) | ± 0.3 milligrams per liter |
| Turbidity | ± 10% NTUs (when turbidity is greater than 10 NTUs) |
| Oxidation-Reduction Potential (ORP) | ± 10 millivolts |

7. Maintain the same pumping rate or reduce slightly for sampling as necessary in order to minimize disturbance of the water column. Sampling should be collected directly from the discharge port of the pump tubing prior to passing through the flow-through cell. Disconnect the pump's tubing from the flow-through cell so that the samples are collected from the pump's discharge tubing. For samples collected for dissolved gases or VOC analyses, the pump tubing needs to be completely full of ground water to prevent the ground water from being aerated as it flows through the tubing. Generally, the sequence of the samples is immaterial unless filtered (dissolved) samples are collected. Filtered samples must be collected last (see below). All sample containers should be filled with minimal turbulence by allowing the ground water to flow from the tubing gently down the inside of the container.

When filling VOC samples using volatile organic analysis (VOA) vials, a meniscus must be formed over the mouth of the VOA vial to eliminate the formation of air bubbles and head space prior to capping. Effervescence and colorimetric reactions should be recorded in the *Low-Flow Purging and Sampling Log*.

8. If a filtered (dissolved) metal sample is to be collected, then an inline filter is fitted at the end of the discharge tubing and the sample is collected after the filter. The inline filter must first be flushed in accordance with manufacturer's recommendations and if there are no recommendations for flushing, a minimum of 0.5 to 1.0 liter of groundwater from the monitoring well must pass through the filter prior to sampling. (Note: Groundwater filter cartridges are dedicated sampling equipment. A new cartridge should be used at each sampling location. Do not attempt to clean filter cartridges. If the filter becomes clogged or groundwater flow is too slowed, remove and replace with a new filter cartridge.)
9. For non-dedicated systems, remove the pump from the monitoring well. Decontaminate the pump and dispose of the tubing. For dedicated systems, disconnect the tubing that extends from the plate at the wellhead (or cap) and discard after use.
10. Close and lock the well.

Special Advisory: If a stabilized drawdown in the well can't be maintained at 0.3 feet and the water level is approaching the top of the screened interval, reduce the flow rate or turn the pump off (for 15 minutes) and allow for recovery. It should be noted whether or not the pump has a check valve. A check valve is required if the pump is to be shut off during purging. Under no circumstances should the well be pumped dry. Begin pumping at a lower flow rate, if the water draws down to the top of the screened interval again, turn pump off and allow for recovery. If two tubing volumes (including the volume of water in the pump and flow cell) have been removed during purging, then sampling can proceed next time the pump is turned on. This information should be noted in the *Low-Flow Purging and Sampling Log*. This behavior may necessitate an alternative purging and sampling procedure for subsequent sampling events.

5.3 Equipment Decontamination

The electronic water level indicator and the water quality meters will be decontaminated by the following procedures:

1. The water level indicator will be hand washed with phosphate-free detergent and a scrubber, then thoroughly rinsed with distilled water, or steam-cleaned.
2. Water quality meter sensors and flow-through cell will be rinsed with distilled water between sampling locations. No other decontamination procedures are necessary or recommended for these meters since they are sensitive instruments. After the sampling event, the flow-through cell and sensors must be cleaned and maintained per the manufacturer's requirements.

Upon completion of the groundwater sample collection the sampling pump must be decontaminated between monitoring wells. The pump and discharge line including

support cable and electrical wires which were in contact with the groundwater in the well casing must be decontaminated by the following procedure:

1. The outside of the pump, tubing, support cable and electrical wires must be pressure-sprayed with soapy water, tap water and distilled water. Spray outside of tubing and pump until water is flowing off of tubing with each rinse. Use bristle brush to help remove visible dirt and contaminants.
2. Place the sampling pump in a bucket or in a short cylinder or well casing (4-inch diameter) with one end capped. The pump placed in this device must be completely submerged in the water. A small amount of phosphate-free detergent must be added with the potable (tap) water.
3. Remove the pump from the bucket or 4-inch casing and scrub the outside of the pump housing and cable.
4. Place pump and discharge line back in the container, start pump and re-circulate soapy water for approximately 2 minutes.
5. Re-direct discharge line to a 55-gallon drum. Continue to add 5 gallons of potable (tap) water.
6. Turn pump off and place pump into a second bucket of potable (tap) water. Continue to add 5 gallons of tap water.
7. Turn off and place pump into a third bucket which contains distilled/deionized water, continue to add 3 to 5 gallons of water.
8. If hydrophobic contaminants are present (such as separate phase (i.e. LNAPL or DNAPL, high levels of PCBs, etc.) an additional decontamination step, or steps, may be required.
9. Decontamination water will be collected and stored on-site for future disposal by the client unless other arrangements have been made.

6 Quality Control Samples

All field Quality Control (QC) samples must be prepared the same as primary samples with regard to sample volume, containers, and preservation. The sample handling and chain-of-custody procedures for the QC samples will be identical to the primary samples. The following are QC samples that may be collected during groundwater sampling:

- A field duplicate is an independent sample collected as close as possible to the same time that the primary sample is collected and from the same source. Field duplicates are used to document sample precision. Field duplicates will be labeled and packaged in the same manner as primary samples so that the laboratory cannot distinguish between the primary sample and the duplicate sample. Field duplicates are analyzed for the same suite of parameters as the primary samples. The frequency of analysis of field duplicates is generally one for every 20 primary samples, but may vary depending on project requirements.
- Equipment blanks are obtained by running distilled or deionized water over or through the

sample collection equipment after it has been decontaminated, and capturing the water in the appropriate sample containers for analysis. Equipment blanks are analyzed for the same suite of parameters as the primary samples. The frequency of analysis of equipment blanks is generally one for every day that non-dedicated sampling equipment is used, but may vary depending on project requirements.

- Field blanks are used to assess the presence of contaminants arising from field sampling procedures. Field blank samples are obtained by filling a clean sampling container with reagent-grade deionized water. Field blanks are analyzed for the same suite of parameters as the primary samples. Field blanks may or may not be incorporated into a groundwater sampling plan depending on project requirements.
- Trip blanks are sample containers that are used to evaluate sample cross-contamination of VOCs during shipment. For groundwater sampling, trip blanks consist of hydrochloric acid-preserved, analyte-free, deionized water prepared by the laboratory in VOA vials that will be carried to the field, stored with the samples, and returned to the laboratory for VOC analysis. Generally, one trip blank is required to accompany each sample shipping container or cooler that contains samples for VOC analysis; however, this may vary depending on project requirements.

7 Sample Handling and Custody

Samples will be collected, handled, and stored in such a manner that they are representative of their original condition and chemical composition. Identification of samples and maintenance of custody are important elements that must also be utilized to ensure samples characterize site conditions. All samples will be properly identified and maintained under chain-of-custody protocol to protect sample integrity. The following sections discuss the sample handling and custody requirements.

7.1 Sample Identification

To maintain consistency, a sample identification convention including unique identifiers for all groundwater and QC samples must be developed and followed throughout the project. The sample identifiers will be entered onto the sample labels, field forms, chain-of-custody forms, and other records documenting sampling activities.

7.2 Sample Labels

A sample label will be affixed to all sample containers sent to the analytical laboratory. Field personnel will complete an identification label for each sample with the following information written in waterproof, permanent ink:

- Client and project number;
- Sample location and depth, if relevant;
- Unique sample identifier;
- Date and time sample collected;
- Filtering performed, if any;
- Preservative used, if any;

- Name or initials of sampler; and
- Analyses or analysis code requested.

The use of pre-printed sample labels is preferred in order to reduce sample misidentification problems due to transcription errors. Sample labels must be completed and affixed to the sample container in the field at the time of sample collection.

If errors are made on a sample label, corrections will be made by drawing a single line through the error and recording the correct information. Corrections will be dated and initialed.

7.3 Containers, Preservation, and Hold Time

Each lot of preservative and sampling containers will be certified as contaminant-free by the supplier. All preserved samples will be clearly identified on the sample label and *Chain-of-Custody* form. If samples requiring preservation are not preserved, field records will clearly specify the reason for the discrepancy.

Chemical activity continues in the sample until it is either analyzed or preserved. Once the sample has been preserved, the sample may be held for a period of time before analysis. The time from the collection of the sample to the analysis is defined as the holding time. The holding time varies depending on the media being sampled and the analyses being performed. The collection, preservation, and analysis of samples must be conducted to avoid exceeding relevant holding times.

7.4 Sample Handling and Transport

Proper sample handling techniques are used to ensure the integrity and security of the samples. Samples for field measured parameters will be analyzed immediately in the field and recorded in the appropriate field forms. Samples for laboratory analysis will be transferred immediately to appropriate laboratory supplied containers in accordance with the following sample handling protocols:

- Don clean gloves before touching any sample containers, and take care to avoid direct contact with the sample;
- Samples will be quickly observed for color, appearance, and composition and recorded as necessary;
- The sample container will be labeled before or immediately after sampling;
- Sample containers and liners will be capped with Teflon™-lined caps before being placed in Ziploc™-type plastic bags. The samples will be placed in an ice chest kept at 4 °C for transport to the laboratory;
- All sample lids will stay with the original containers, and will not be mixed;
- Sample bottles will be wrapped in bubble wrap as necessary to minimize the potential for breakage during shipment; and
- The *Chain-of-Custody* form will be placed in a separate plastic bag and taped to the cooler

lid or placed inside the cooler. A custody seal will be affixed to the cooler if the samples are to be shipped by commercial carrier. For shipped samples, U.S. Department of Transportation shipping requirements will be followed and the sample shipping receipt will be retained in the project files as part of the permanent Chain-of-Custody document.

7.5 Sample Chain-of-Custody

Sample chain-of-custody procedures will be used to maintain and document sample integrity during collection, transportation, storage, and analysis. A sample is considered to be under the control of, and in the custody of, the responsible person if the samples are in their physical possession, locked or sealed in a tamper-proof container, or stored in a secure area.

The *Chain-of-Custody* form provides an accurate written record that traces the possession of individual samples from the time of collection in the field until they are accepted at the analytical laboratory. The *Chain-of-Custody* form also documents the samples collected and the analyses requested. The sampler will record the following information on the *Chain-of-Custody* forms:

- Client and project number;
- Name or initials and signature of sampler;
- Name of destination analytical laboratory;
- Name and phone number of Project Leader in case of questions;
- Unique sample identifier for each sample;
- Date and time of collection for each sample;
- Number and type of containers included for each sample;
- Analysis or analyses requested for each sample;
- Preservatives used, if any, for each sample;
- Sample matrix for each sample;
- Any filtering performed, if applicable, for each sample;
- Signatures of all persons having custody of the samples;
- Dates and times of transfers of custody;
- Shipping company identification number, if applicable; and
- Any other pertinent notes, comments, or remarks.

Blank spaces on the *Chain-of-Custody* will be crossed out and initialed by the field sampler between the last sample listed and the signatures at the bottom of the sheet.

The field sampler will sign the *Chain-of-Custody* and will record the time and date at the time of transfer to the laboratory or an intermediate person. A set of signatures is required for each relinquished/received transfer, including internal transfer. The original imprint of the *Chain-of-*

Custody will accompany the sample containers and a duplicate copy will be kept in the project file.

If the samples are to be shipped to the laboratory, the original *Chain-of-Custody* relinquishing the samples will be sealed inside a plastic bag within the ice chest, and the chest will be sealed with custody tape that has been signed and dated by the last person listed on the *Chain-of-Custody*. U.S. Department of Transportation shipping requirements will be followed and the sample shipping receipt will be retained in the project files as part of the permanent *Chain-of-Custody* document. The shipping company (e.g., Federal Express, UPS) will not sign the *Chain-of-Custody* forms as a receiver; instead the laboratory will sign as a receiver when the samples are received.

8 Field Documentation

Information collected during groundwater sampling may be recorded on individual field forms. If the project requires it, a project-specific Field Logbook may replace any of the individual field forms with the exception of the *Chain-of-Custody* form. Following review by the Project Manager, the original field records will be kept in the project file. The following forms may be used to document the field activities:

- *Field Investigation Daily Log*
- *Water Level Measurement Log*
- *Low-Flow Purging and Sampling Log*
- *Equipment Calibration Log*
- *Chain-of-Custody*

The *Field Investigation Daily Log* will be completed for each day of fieldwork containing (at a minimum) the times and descriptions of the work performed, the activities of the drillers and any other subcontractors or visitors on-site, arrival and departure times for all involved, and any other pertinent information. For larger projects, or when otherwise deemed appropriate by the Project Manager, this information may alternatively be recorded in a Field Logbook. In these cases, a separate Field Logbook must be used for each project or site.

The *Water Level Measurement Log* will be used to record water level measurements for all wells prior to commencement of groundwater sampling. The type, serial number, and calibration date for the water level measuring device will be included on this form. Additionally, this form will be used to record general observations of the conditions of the wells, wellheads, well boxes, and/or monuments.

The *Low-Flow Purging and Sampling Log* will be used to record the details of purging and sampling information for each well including the depth of the pump, purge rates, and volume purged from each well. This form will also be used to record all of the measurements of drawdown and water quality indicator parameters used for evaluating stabilization.

The *Equipment Calibration Log* will be used to document the calibration and status of any measuring instruments used in the field, e.g., PID/FID, water level measuring device, water quality meters, etc. The frequency and method of calibration will depend on the instrument. Any instruments used will be used in accordance with the factory-provided operating and/or service manuals.

Locations and unique identification of water samples collected from the monitoring wells will be recorded on the *Field Investigation Daily Log*, *Low-Flow Purging and Sampling Log*, a site map, and/or other appropriate forms.

Samples names, date/times, analyses to be performed, and other pertinent information will be recorded on the *Chain-of-Custody* form (discussed in Section 7.5) as a means of identifying and tracking the samples.

Standard Operating Procedure B-3: Monitoring Well Installation and Development

This standard operating procedure (SOP) is applicable to the installation and development of wells for groundwater monitoring or remediation purposes. This SOP is generic in nature and may be modified in whole or part depending on constraints presented by site conditions and equipment limitations. Modifications of methodologies will be documented in the appropriate field logbook and discussed in reports summarizing field activities. The procedures herein are consistent with Title 35 Section 620E.505(a)(5)(F) of the Illinois Rules.

Well Installation

Prior to invasive activities, a subsurface utility check will be conducted. Wells will generally be constructed using 5- to 20-foot-long screen and sufficient riser to complete the well to, or slightly above, ground surface. The length of the well screen will be selected based on the planned use of each well and the observed lithology. Wells will be constructed using schedule 40 polyvinyl chloride (PVC) casing and 0.010 slot schedule 40 PVC well screen with a threaded bottom cap. Wells will generally be completed with a protective steel cover equipped with a lock to protect the well against damage and unauthorized entry.

Filter Material

Filter material will be well-graded, clean sand (generally less than 2-percent by weight passing a No. 200 sieve and less than 5 percent by weight of calcareous material).

Setting Wells

Upon completion of borehole drilling, the boring will be sounded to determine the total depth, and the PVC well materials will be assembled and lowered into the boring. PVC well materials will be measured to the nearest 0.1 foot and will be assembled such that the screened interval is positioned opposite the target formation. No PVC cement or other solvents will be used. Once the well has been positioned at the desired depth, filter sand will be slowly added to the borehole to fill the annular space to a depth approximately 1 to 2 feet above the top of the well screen. During sand placement, the driller will continually measure the depth to the sand using a weighted tape measure or other device to verify that the sand does not bridge between the auger and the well screen. Two feet of bentonite chips will be added on top of the filter sand and subsequently hydrated using clean, municipal water to form a transition seal. After the bentonite has hydrated for at least 30 minutes, the depth to the top of the bentonite will be measured and recorded. A neat cement/bentonite grout will be added from the top of the bentonite; a tremie pipe will be utilized to ensure that the grout is added from the bottom, upwards. The grout will be permitted to cure for 48 hours prior to well development.

Well Completion

All monitoring wells and monitoring points will be completed with a protective steel cover equipped with a lock to protect the well against damage and unauthorized entry. Wells will typically be completed above grade unless they are located within parking/driving areas, or are piped to a remediation system. Wells completed aboveground will be capped with a push-on well cap and completed with a steel stick-up casing. Wells completed below ground surface will

be capped with an expandable locking well cap and completed with a flush mounted traffic rated steel cover set into a 2 foot by 2 foot concrete pad. All wells will be labeled with a permanent marker that includes the well ID.

Development and Surveying

New wells will be developed after the grout has cured for a minimum of 48 hours. Wells will be developed by surging, bailing, and pumping to reduce or remove drilling-induced formation smear from the borehole walls, to remove sediment that may have accumulated during well installation, consolidate the filter pack, and to enhance the hydraulic connection between the formation target zone and the well. In most cases, a bailer or pump will be used to remove sediment and turbid water from the bottom of the well. A surge block will then be lowered up and down within the screened interval to flush the filter pack of fine sediment and remove smear from borehole walls. Following surging, the well will be bailed or pumped again to remove sediment and turbid water. Water will be removed from the well at a rate greater than the anticipated future pumping rate and water quality parameters including pH, turbidity, specific conductance and temperature will be recorded. Drawdown will also be recorded with an interface probe or water level meter. The development will proceed until sediment is removed sufficiently to achieve a turbidity measurement of 5 NTU (or less). The well installation report will specify if the target turbidity cannot be achieved.

Following well installation and completion, each well will be surveyed by a licensed surveyor to determine the location of the well and to establish the elevation at the top of casing and ground surface with reference to the site datum. Survey data will be incorporated into the database and onto the site base map.

Decontamination of Drilling Equipment

All drilling and well development equipment will be cleaned prior to use, and between wells. Drilling equipment will be steam cleaned, rinsed with potable water, and air dried. If equipment is not immediately put back to use, equipment will be covered with clean plastic to protect the materials from contact with dust or other contaminants. Pumps or other non-dedicated field equipment that comes into contact with impacted media will be cleaned using a non-phosphate detergent followed by a tap water rinse and a final, deionized water rinse. Decontamination water will be collected for appropriate, subsequent off-site disposal. Spent PPE or other disposable materials (e.g., tubing) will be placed into a drum for subsequent disposal.

Documentation

Well installation and construction activities will be recorded in the field notebook. A well construction diagram will be completed for each well, reviewed by appropriate personnel for completeness and accuracy, and filed electronically in the project file. The CQA Officer will complete and submit an IEPA Well Completion form for each well.

References

Illinois Rules, Title 35 Section 620E.505(a)(5)(F).

Standard Operating Procedure B-4: Photoionization Detector (PID) Screening

This standard operating procedure (SOP) is applicable to the use of a photoionization detector/flame ionization detector (PID/FID) instrument during soil sampling activities. The methodology is generic in nature and may be modified in whole or part to meet the handling and analytical requirements of the contaminants of concern, as well as the constraints presented by site conditions and equipment limitations. Modifications of sampling methodologies will be documented in the appropriate field logbook and discussed in reports summarizing field activities and analytical results. For the purposes of this procedure, soils are those mineral and organic materials not submerged in water for an extended period of time sufficient to support aquatic life.

Equipment/Apparatus

Equipment needed for PID/FID screening of soil samples may include:

- PID/FID instrument
- Clear glass jar
- Aluminum foil
- Ziploc bags

Procedure

When using PID/FID instrument the following procedure must be used:

- Half-fill **either** a glass jar, or a Ziploc® baggie.
 - When using glass jars:
 - Fill jars with a total capacity of 8 oz. or 16 oz.
 - Seal each jar with one (1) or two (2) sheets of aluminum foil with the screw cap applied to secure the aluminum foil.
 - When using Ziploc® baggies:
 - Half fill bags from the split spoon or the excavation.
 - Zip to close.
- Vigorously shake the sample jars or bags for at least thirty (30) seconds once or twice in a 10- to 15-minute period to allow for headspace development.
- If ambient temperatures are below 32 degrees Fahrenheit (0 degrees Celsius) headspace development is to be within a heated vehicle or building.
- Quickly insert the PID/FID sampling probe through the aluminum foil. If plastic bags are used, unzip the corner of the bag approximately one to two inches and insert the probe or insert the probe through the plastic. Record the maximum meter response (should be within the first 2 to 5 seconds). Erratic responses should be discounted as a result of high organic vapor concentrations or conditions of elevated headspace moisture.
- Record headspace screening data from both jars or bags for comparison.

- Calibration will be checked/adjusted daily. In addition, all manufacturers' requirements for instrument calibration will be followed.
- If sample jars are re-used in the field, jars will be cleaned according to field decontamination procedures. In addition, headspace readings must be taken to ensure no residual organic vapors exist in the cleaned sample jars.
- Plastic bags will not be reused.

Appendix C

Research Laboratory Bench-Scale Testing Protocols

TREATABILITY STUDIES FOR PERCHLORATE FROM AQUIFER MATERIAL AT THE NEVADA ENVIRONMENTAL TRUST SITE

John H Pardue PhD, PE and W. Andrew Jackson, PhD, PE

Creation of a permeable reactive barrier (PRB) is one strategy to reduce perchlorate to nontoxic end products in contaminated aquifers. Kinetic information on perchlorate reduction and the identity of suitable electron donors is required to effectively design PRBs for this purpose. The treatability studies proposed below are designed to identify suitable electron donors that will drive perchlorate reduction without seriously impacting the permeability of the formation or causing unacceptable downgradient water quality impacts. The site of interest is the Nevada Environmental Response Trust (NERT) site in Henderson, NV. Based on previous microcosm studies, perchlorate reduction is electron donor limited in the Las Vegas wash and in the contaminated groundwater (Battista et al., 2003). Reduction will not occur in the absence of a supplemental carbon source. Required dosage is unknown and depends on the background demand from other electron acceptors and the demand from perchlorate reducers. The goal of these treatability studies is to identify the identity and dose of a suitable carbon source.

1.1 Objectives

The overall objective of these bench-scale studies is to ensure success for a pilot PRB. The specific objectives of the proposed bench-scale treatability studies are:

1. Identification of suitable electron donors for perchlorate reduction
2. Measurement of perchlorate reduction kinetics in NERT aquifer material.
3. Establish kinetic and hydraulic parameters required to design a PRB pilotTasks

1.2 Tasks

Task 1. Identification of suitable organic donors

Soluble, slow-release and solid electron donors will be tested to establish candidate amendments for perchlorate reduction in the PRB pilot. Example soluble donors may include acetate, lactate or mixed donors (e.g., yeast extract) (Coates and Jackson, 2009). Proprietary slow-release donors will also be tested. These will be contrasted with a mixture of peat and sand to mimic construction of a PRB out of a solid electron donor instead of amendment of the existing aquifer material. A total of 8-10 donors will be evaluated. Final selection of the amendments will be made jointly with ENVIRON. To establish effectiveness, serum bottle testing will be conducted on mixtures of site aquifer material, site groundwater and different concentrations of candidate donors. Testing will be conducted using methods described in the attached SOP. Briefly, materials will be assembled in a glove box in 160 mL serum bottles sealed with Teflon-lined septa and crimp caps (Tan et al., 2004 and Jackson et al., 2004). Bottles will be repetitively sampled over time to establish the kinetics of perchlorate reduction. In addition to perchlorate, concentrations of relevant redox pairs will be measured as the

changes in the aquifer material/groundwater systems progress. These will include oxygen, nitrate/nitrite, ferric/ferrous iron, sulfate/sulfide and methane. Studies will be run for 6-8 weeks or until the perchlorate is reduced by 80-90%. Successful electron donors will be evaluated based on kinetics of perchlorate reduction and mitigation of lag time due to presence of oxygen and nitrate. Cost and implementability will be additional strong considerations for candidate donors for further evaluation in 1-D columns.

Task 2. Assessment of perchlorate reduction kinetics in 1-D columns

Column studies will be used to test the effectiveness of donors in a flow-through mode. Successful donors will be those that reduce perchlorate but also maintain the hydraulic properties of the formation (minimize biofouling). A schematic diagram of the 1-D column system is shown in Figure 1. Column experiments will be performed in three, 5 ft long, 2 inch diameter columns with 5 equispaced sampling ports located along their lengths. The columns will be packed with aquifer material from the NERT site. A 5 cm layer of fine gravel will be placed at the bottom for even distribution of flow through the column. Glass wool will be inserted in the inner side of sampling ports to avoid dead zones and clogging of sampling ports. Immediately after establishment of the columns, the hydraulic conductivity of the test columns will be assessed by connecting a falling head permeameter to the column. Hydraulic conductivity will be measured using the falling head method and compared to existing site data.

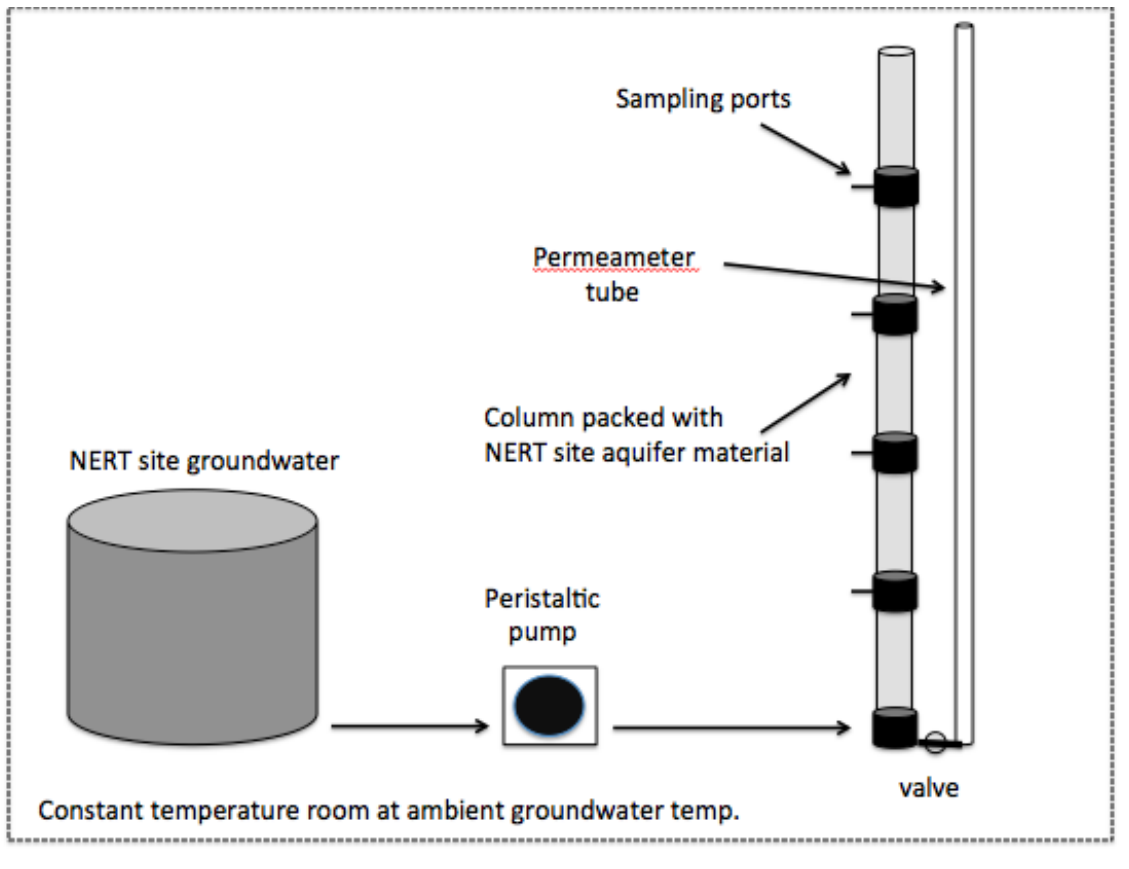

Figure 1. Column set-up

Contaminated groundwater, shipped from the site, will be introduced through 2 mm stainless steel tubing in upflow mode. A peristaltic pump (Cole Parmer Masterflex) with Viton tubing will be used to convey water through the column at groundwater velocities representative of site conditions. The experiment will be set-up in a constant temperature room so that site groundwater and the test columns will be maintained at the ambient site temperature.

The influent concentrations will be monitored three times a week to track changes in perchlorate concentration. Influent samples for all column experiments will be collected at the sampling ports on the delivery side of the pump. Samples were collected with a 5 mL prerinsed airtight glass syringe fitted with luer-lock and injected into 2 mL glass vials. Sampling was performed after every three-four days for determination of perchlorate concentration, nitrate/nitrite concentrations and conductivity. On a weekly basis, additional redox indicators will be measured including O₂, nitrite, nitrate, ferrous iron, ferric iron, sulfate and sulfide, and methane. Redox characteristics of each sampled zone would be determined from these multiple lines of evidence from the water chemistry testing. Additional samples will be removed for metals analysis at an external certified laboratory acceptable to ENVIRON. Column studies will be run for 12 weeks, subject to extension if additional information is desired. Following the termination of the studies, the falling head permeameter study will be repeated and the hydraulic conductivity measured again. Declines in conductivity over the 12 weeks may be evidence of biofouling. If conductivity declines significantly (>5-10x), column materials will be removed and total carbon measured on the aquifer material to determine the amount of biomass accumulated along the flowpath.

Task 3. Establishing kinetic and hydraulic parameters

Column data for removal of perchlorate can be assessed using 1-D reactive-transport models:

$$\frac{\partial C}{\partial t} = -\frac{u_x}{R} \frac{\partial C}{\partial x} + \frac{D_x}{R} \frac{\partial^2 C}{\partial x^2} - \frac{k}{R} C$$

Because of the uncertainty in the scale-dependent dispersion term, D_x (the dispersion term is very small over the short depth of the columns), a simpler exponential equation can also be used to assess kinetics for perchlorate treatment.

$$C = C_o e^{-kRx/v}$$

where C [M/L³] is the concentration of the pollutant at a vertical distance, x [L], C_o [M/L³] is the initial concentration, k [T⁻¹] is a lumped temporal degradation rate constant, R is the retardation coefficient and v [L/T] is the seepage velocity. The equation captures several important mechanisms including equilibrium partitioning, advection and first-order reduction of perchlorate. Partitioning is expected to be negligible for perchlorate (e.g., $R=1$). Biodegradation rate constants will be determined by fitting the equation to contaminant profiles measured in Task 2 using CXTFIT, a curve fitting program used for 1-D column

studies (Toride et al., 1995) or using non-linear regression for the simpler exponential equation.

1.2.1 Analytical Procedures

Major anions (Cl^- , NO_3^- , and SO_4^{2-}) will be analyzed by ion chromatography following EPA Method 300.0. ClO_4^- concentrations will be separately measured by sequential ion chromatography-mass spectroscopy-mass spectroscopy (IC-MS/MS). ClO_4^- will be quantified using a Dionex LC 20 ion chromatography system consisting of GP50 pump, CD25 conductivity detector, AS40 automated sampler and Dionex IonPac AS16 (250 X 2 mm) analytical column. The IC system is coupled with an Applied Biosystems – MDS SCIEX API 2000™ triple quadrupole mass spectrometer equipped with a Turbo-IonSpray™ source. A hydroxide (NaOH) eluent at 0.3 mL min^{-1} is followed by 90% acetonitrile (0.3 mL min^{-1}) as a post-column solvent. To overcome matrix effects, all samples were spiked with Cl^{18}O_3 or Cl^{18}O_4 internal standards. Redox parameters will be measured using standard methods: O_2 (microelectrode), nitrite, nitrate, ferrous, ferric iron, sulfate, sulfide (ion chromatography), methane in porewater (GC-FID), SOPs of each of these measurements are available upon request.

QA/QC

Full details of QA/QC procedures are available in the SOPs. Briefly, the QC program consists of blanks, calibration checks, matrix spikes and matrix spike duplicates. Our QA/QC for these parameters has been approved by a number of agencies including the US Army, Florida DEQ and others. Split samples will be provided for analysis at external laboratories at ENVIRON's request.

References:

Batista, Jacimaria R. , Amy, Penny S. , Chen, Yi-Tung , Papelis, Lambis , Unz, Richard. 2003. The Fate and Transport of Perchlorate in a Contaminated Site in the Las Vegas Valley. Part A: Investigation of the Influence of Biological Degradation and Sorption on the Fate of Perchlorate. Part B: Modeling of the Transport of Perchlorate in the Las Vegas Wash. Final Project Report EPA Grant Number: R827622E03

J. Coates and W.A. Jackson. 2009. Development of *In Situ* Bioremediation Technologies for Perchlorate in In Situ Bioremediation of Perchlorate in Groundwater. Hans F. Stroo and Herb Ward, (Eds.) 2009, XLVI, PP. 29-53.

Jackson, W. Andrew, M. Jeon, J. H. Pardue, and T. Anderson. 2004. Enhanced Natural Attenuation of Perchlorate in Soils Using Electrokinetic Injection. Bioremediation Journal. 8(1-2):65-79.

Tan, K., T.A. Anderson and W.A. Jackson. 2004. Degradation Kinetics of Perchlorate in Sediments and Soils. Water, Air, and Soil Pollution. 151:245-259.

Toride, N., F. J. Leij, and M. Th. van Genuchten. 1995. The CXTFIT Code for Estimating Transport Parameters from Laboratory or Field Tracer Experiments, Version 2.0. Research Report No. 137, U.S. Salinity Laboratory, USDA, ARS, Riverside, California.

Appendix E
In-Situ Soil Flushing Treatability
Study Work Plan



**Treatability Study Work Plan
In-Situ Soil Flushing
Nevada Environmental Response
Trust Site; Henderson, Nevada**

Prepared for:
Nevada Environmental Response Trust

Prepared by:
**ENVIRON International Corporation
Chicago, Illinois**

Date:
December 17, 2012

Project Number:
21-29100H H06



Treatability Study Work Plan In-Situ Soil Flushing

**Nevada Environmental Response Trust
(Former Tronox LLC Site)
Henderson, Nevada**

Nevada Environmental Response Trust (NERT) Representative Certification

I certify that this document and all attachments submitted to the Division were prepared at the request of, or under the direction or supervision of the Trust. Based on my own involvement and/or my inquiry of the person or persons who manage the system(s) or those directly responsible for gathering the information or prepared the document, or the immediate supervisor of such person(s), the information submitted and provided herein is, to the best of my knowledge and belief, true, accurate, and complete in all material respects.

Le Petomane XXVII, Inc., not individually, but solely in its representative capacity as the Nevada Environmental Response Trust Trustee

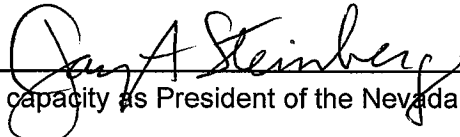
Signature:  not individually, but solely in his representative capacity as President of the Nevada Environmental Response Trust Trustee

Name: Jay A. Steinberg, not individually, but solely in his representative capacity as President of the Nevada Environmental Response Trust Trustee

Title: Solely as President and not individually

Company: Le Petomane XXVII, Inc., not individually, but solely in its representative capacity as the Nevada Environmental Response Trust Trustee

Date: 12/14/12

Contents

| | Page |
|--|-------------|
| 1 Introduction | 1 |
| 1.1 Background / Regulatory Status | 1 |
| 1.1.1 Groundwater Contamination | 1 |
| 1.1.2 Soil Contamination | 1 |
| 1.2 Purpose and Objectives | 1 |
| 1.3 Work Plan Organization | 2 |
| 2 Work Performed by Others | 4 |
| 3 Candidate Installation Location | 5 |
| 4 Site Conditions | 6 |
| 4.1 Local Geology | 6 |
| 4.2 Perchlorate in Soil | 6 |
| 4.3 Hydrology | 6 |
| 4.4 Perchlorate in Groundwater | 7 |
| 5 Preliminary Field Testing | 8 |
| 5.1 Permeameter Testing | 8 |
| 5.2 Flushing Fluid Characterization | 8 |
| 6 Preliminary Pilot System Design & Operation | 9 |
| 6.1 Preliminary Design | 9 |
| 6.1.1 Flushing Volume | 9 |
| 6.1.2 Hydraulic Loading | 9 |
| 6.1.3 Groundwater Mounding | 10 |
| 6.1.4 Potential Impacts to the GWETS | 11 |
| 6.2 Water Delivery System Operation | 11 |
| 6.3 Time to Complete Pilot Test | 12 |
| 6.4 Permitting | 12 |
| 7 Pilot System Monitoring | 13 |
| 7.1 Leachate Monitoring | 13 |
| 7.2 Soil | 13 |
| 7.3 Groundwater Monitoring | 14 |
| 8 Reporting | 15 |
| 9 Schedule | 16 |
| 10 References | 17 |

List of Figures:

- Figure 1: Site Location Map
- Figure 2: Proposed Pilot Test Location
- Figure 3: Perchlorate Concentrations at the Proposed Pilot Test Location
- Figure 4: Utilities near the Proposed Pilot Test Location
- Figure 5: Interceptor Trench Projected Capture Zone
- Figure 6: Groundwater Potentiometric Surface near the Proposed Pilot Test Location
- Figure 7: Perchlorate Concentrations in Groundwater near the Proposed Pilot Test Location
- Figure 8: Propose Soil Flushing Process Flow Schematic
- Figure 9: Pilot Test Monitoring Layout – Soil Flushing Treatability Study
- Figure 10: Preliminary Time Schedule for In-situ Soil Flushing Treatability Study

List of Tables:

- Table 1: Water Sampling Analytes and Methods
- Table 2: Soil Sampling Analytes and Methods

List of Appendices:

- Appendix A: Boring Logs and Well Construction Diagrams
- Appendix B: ENVIRON Standard Operating Procedures
- Appendix C: Infiltration and Mounding Calculations

Acronyms and Abbreviations

| | |
|-----------|---|
| AWF | Athens Road Well Field |
| BCL | Basic Comparison Level |
| bgs | below ground surface |
| COPC | Chemical of Potential Concern |
| ECA | Excavation Control Area |
| ENVIRON | ENVIRON International Corporation |
| FBRs | Fluidized Bed Reactors |
| fp | Infiltration Rate |
| g/L | grams per liter |
| GWETS | Groundwater Extraction and Treatment System |
| H | Recharge basin head at discharge point |
| IWF | Interceptor Well Field |
| K_{sat} | saturated hydraulic conductivity |
| L | Depth to wetting front |
| mg/L | milligrams per liter |
| mg/kg | milligrams per kilogram |
| mL: | milliliter |
| NDEP | Nevada Division of Environmental Protection |
| NPDES | National Pollutant Discharge Elimination System |
| NRS | Nevada Revised Statutes |
| PVC | polyvinyl chloride |
| Qal | Quaternary Alluvium |
| RAO | Remedial Action Objective |
| RI/FS | Remedial Investigation / Feasibility Study |
| S_f | Suction head |
| Site | Trust site |
| SOP | Standard Operating Procedures |
| SRG | Site Remediation Goal |
| SWF | Seep Well Field |
| Trust | Nevada Environmental Response Trust |
| UMCf | Upper Muddy Creek Formation |

UIC Underground Injection Control

1 Introduction

ENVIRON International Corporation (ENVIRON) on behalf of the Nevada Environmental Response Trust (the Trust) has prepared this Treatability Study Work Plan for In-Situ Soil Flushing for the Nevada Division of Environmental Protection (NDEP). This Work Plan details the pilot test conceptual design and preliminary field work necessary for conducting the proposed field-scale pilot of an in-situ soil flushing system (the Pilot System) at the Trust site in Henderson, Nevada (the Site). The location of the Site is shown in Figure 1. The proposed pilot testing continues and builds on the soil flushing evaluation started by Tronox in 2010.

1.1 Background / Regulatory Status

1.1.1 Groundwater Contamination

The Site has been undergoing active remediation to manage hexavalent chromium groundwater contamination (since 1986) and perchlorate contamination of groundwater (since 1998), under consent orders issued by NDEP to the Kerr McGee Chemical Corporation. Both contaminants are treated by means of a groundwater extraction system and on-site treatment facilities, collectively referred to as the Groundwater Extraction and Treatment System (GWETS). Groundwater is collected at three well fields: the on-site Interceptor well field (IWF), the off-site Athens Road well field (AWF), and the off-site Seep Area well field (SWF). Groundwater collected from the IWF is first treated to reduce hexavalent chromium to trivalent chromium through a ferrous sulfate treatment system. After the ferrous sulfate treatment process, perchlorate is treated using perchlorate-reducing bacteria in a series of fluidized bed reactors (FBRs). Groundwater extracted from the AWF and SWF is discharged directly to the FBR process for perchlorate removal. Following treatment, groundwater is discharged to the Las Vegas Wash under a National Pollutant Discharge Elimination System (NPDES) permit.

1.1.2 Soil Contamination

In accordance with an NDEP Order issued to Tronox in 2009, Tronox prepared a Removal Action Work Plan to remove shallow soil containing chemicals of potential concern (COPCs) above NDEP approved Site Remediation Goals (SRGs). These removal activities were commenced by Tronox in August 2010 and were completed by the Trust in November 2011 (ENVIRON, 2012a). The excavation activities addressed in this program were limited to the upper 10 feet below ground surface (bgs). Deeper vadose zone soils were not addressed during this removal action.

1.2 Purpose and Objectives

As stated above, the previous removal action only addressed shallow soils (i.e., less than 10 feet bgs) to mitigate direct contact risks. The removal action did not address deeper soils potentially containing constituents posing a threat to underlying groundwater. Such areas of the Site are now being addressed as part of the overall RI/FS process, a component of which is to identify feasible and cost-effective technologies that could be effective in meeting the Remedial Action Objectives (RAOs) for the Site. In-situ soil flushing has been identified as a promising technology that could be useful in meeting these RAOs.

The purpose of this Work Plan is to present the steps necessary to install, operate and monitor a pilot scale in-situ soil flushing system to remove perchlorate from vadose zone soils.

Perchlorate is highly soluble in water – approximately 200 grams per liter (g/L) at 20 degrees Celsius – making it a good candidate for soil flushing. This has been verified through laboratory column testing (see Section 2) that demonstrated this technology has the potential to reduce perchlorate concentrations in Site vadose zone soils by up to 99%. If successful, flushing of perchlorate from deep soils would help to reduce the overall mass of perchlorate in soils and potentially decrease the remedial time frame for achieving site RAOs. The pilot system will provide additional information to determine if an in-situ soil flushing system combined with the current GWETS can cost-effectively remove and treat perchlorate concentrations from in-situ Site soils.

The specific objectives of the pilot test are to:

- Evaluate the performance of the soil flushing system to reduce the leachable fraction of perchlorate in soils to reduce perchlorate impacts to groundwater;
- Evaluate the potential for other constituents of concern to be mobilized during flushing operations;
- Determine the extent and impact of soil flushing-induced groundwater mounding; and
- Determine the optimal operational conditions for flushing perchlorate from the vadose zone while controlling groundwater mounding.

In addition to the specific objectives stated above, this Work Plan proposes the use of GWETS effluent as a flushing liquid. Although stabilized Lake Mead water has been proposed in previous studies/work plans (Northgate, 2010a, 2010c, Prima 2010), the use of GWETS effluent offers a potentially cost-effective and more sustainable alternative and its effectiveness will be evaluated in this program.

1.3 Work Plan Organization

This Work Plan relates to the proposed field-scale trial for a soil flush amendment to the existing treatment system and is organized as follows:

- Section 2 presents a summary of relevant work done by others;
- Section 3 presents the proposed candidate location for the pilot-scale soil flushing system on the Site;
- Section 4 presents the site conditions in the proposed pilot test location;
- Section 5 presents the preliminary field testing proposed to be performed to enable final design of the pilot-scale soil flushing system;
- Section 6 presents the preliminary design of the soil flushing pilot system along with operational considerations;
- Section 7 details the monitoring to be performed during the pilot system operation;
- Section 8 describes the reports of results of the pilot testing to be prepared;

- Section 9 presents the proposed schedule; and
- Section 10 details the references used in compiling this Work Plan.

Figures and tables are presented at the back of the report text, followed by the Appendices.

2 Work Performed by Others

An assessment of soil flushing as a remedial option for Site soils was initiated by Northgate (on behalf of Tronox) in 2010 (Northgate, 2010a). As part of their feasibility assessment, Northgate commissioned Prima to perform column tests using Site-derived soil and groundwater to enable bench scale evaluation of perchlorate removal via soil flushing and the resultant influence on metals mobilization (Prima, 2010).

The column tests used homogenized Site-derived soils with low (6.18 milligrams per kilogram (mg/kg)), medium (145 mg/kg) and high (3,310 mg/kg) concentrations of perchlorate. Approximately 2 pore volumes of stabilized Lake Mead water was added to the columns at a rate of 2 milliliters (mL) per minute. The column flushing tests determined that water percolated steadily into the soils at a rate of 30 to 40 inches per day when continuously applied. The addition of 2 pore volumes of water achieved greater than 99% removal of perchlorate from all three soils by the end of the study¹ (Prima, 2010).

The tests concluded that soil flushing appeared to be an effective method of removing perchlorate from the soil; that metals concentrations in the leachates generally increased in the initial samples but then decreased; and that further work was necessary to determine the amount of water needed to ensure complete flushing of perchlorate from vadose zone soils at the Site (Prima, 2010).

Following completion of the column tests, Northgate submitted a work plan (Northgate, 2010c) for field-scale pilot testing at the Site. Although this plan was not implemented, ENVIRON has reviewed Northgate's work plan along with the associated NDEP comments and has incorporated relevant details into this Work Plan.

¹ There are some anomalies in the mass balance calculations of perchlorate in the soil and in the resulting leachate which are discussed in the Prima report.

3 Candidate Installation Location

ENVIRON is proposing to conduct the soil flushing pilot test in the area southwest of the BT Tank Farm as shown in Figure 2. This candidate location was selected based on the following rationale:

- The concentration of perchlorate in vadose zone soils appears consistently at elevated levels (i.e., greater than the BCL of 795 mg/kg), which may represent a significant source to underlying groundwater. Figure 3 shows perchlorate concentrations in soil at the proposed pilot test location. Post-excavation soil concentrations of perchlorate in the top 10 feet of soil at the Site range from 943 to 2,620 mg/kg based on soil samples collected from locations RSAM5, SA15 and SA65 (Northgate 2010c).
- The proposed location is outside of the excavation control areas (ECAs) established in the Site Management Plan, but contains perchlorate concentrations in shallow soils (0-10 bgs) above BCLs.
- Utility connections, including GWETS effluent water and electric, are present in the vicinity of the proposed pilot location (Figure 4). Existing piping and tanks may be utilized to supply water to the proposed location.
- The proposed location is within the projected capture zone of the GWETS interceptor extraction well system (Figure 5) and in an area where the surface of the Upper Muddy Creek Formation (UMCf) slopes toward the IWF. Both conditions will allow for capture and treatment of flushing fluids from the pilot test.
- The proposed location is out of the way of on-going site operations (e.g., GWETS and Tronox operations), but is located within the Site's active central storm water collection basin. Observations since the completion of the soil excavation activities indicate that the maximum ponded water depth in the central basin was approximately three to six inches after an approximately 1.65-inch precipitation event over a 24-hour period at the Site in August 2012. According to National Oceanic and Atmospheric Administration precipitation frequency estimates, a 1.65-inch storm event over 24-hours has a 10 year average return period. Given the shallow observed water depths and low frequency of large storm events in the region, pilot operations would not likely be impeded by storm events at this location in the proposed central basin location. As discussed further in Section 5, the pilot system will be constructed to prevent storm water collected in the basin from impacting pilot operations.

Based on the available data and site conditions, the candidate installation location will allow for assessment of the stated pilot test objectives. This area may be subject to change based on the results of the preliminary field work discussed in Section 5. A location change, if necessary, will be discussed as a part of the preliminary field work and final pilot test design submittal.

4 Site Conditions

4.1 Local Geology

The local geology and hydrology are defined by data collected from more than 1,100 borings and wells that have been installed in the area. The following provides a summary of the geology present in the area of the proposed pilot test based on borehole logs for borings in the area (as presented in Appendix A), but accounting for removal of the upper 10 feet of shallow soil during remedial excavations in 2010/2011 (ENVIRON, 2012c).

- **Fill Material** is not present in the location; but present in other areas of the site.
- **Quaternary Alluvium** generally comprises brown to yellowish brown heterogeneous horizons of sand, gravel and clay with varying degrees of silt content throughout. The gravel is not fully described but is likely to be similar to that across the rest of the Site, i.e., fine, sub-rounded volcanic rock. Caliche (hardened deposits of calcium carbonate) is also recorded as thin bands (up to 4 feet thick) of nodules and was encountered at varying depths, most notably in borehole SA15 where it was encountered from the current ground surface in bands to approximately 22 feet bgs (immediately above the UMCf).
- **Tertiary Upper Muddy Creek Formation** is known to underlie the alluvial deposits but was recorded in only two locations near the proposed pilot area. At SA15, the UMCf was encountered at 22 feet bgs and was described as light brown slightly sandy silt. The full thickness of the UMCf was not determined at SA15 as the boring terminated within the formation. The UMCf was also encountered in monitoring well M-111A at 20 feet bgs; M-111A was removed during the soil excavation work in 2011.

4.2 Perchlorate in Soil

In the area near the proposed pilot location, the Phase A and B investigations data indicate perchlorate concentrations ranging from 943 (SA-15 at 9.0 to 10.5 feet bgs) to 2,620 mg/kg (RSAM5 at 1.0 to 2.5 feet bgs) are present in the shallow vadose zone soils (Northgate, 2010c) that remain following the recent soil removal action. Figure 3 shows perchlorate concentrations in soil at the proposed pilot location. Other areas with elevated perchlorate concentrations (e.g., greater than 1,000 mg/kg) include the former ammonium perchlorate (AP) manufacturing areas near the current GWETS system, AP-5 pond and Central retention basin; and soils near Units 4 and 5.

4.3 Hydrology

Figure 6 shows the potentiometric surface map for the proposed soil flushing pilot location based on the data presented in ENVIRON, 2012c. For the pilot test, the water bearing zone of interest is the Shallow Zone, consisting of the saturated portion of the Qal and the UMCf. Due to the influence of the IWF, groundwater is typically only found in the UMCf under the proposed pilot test location. The groundwater flow direction in the shallow zone at the Site is generally to the north to slightly west of north. Patterns in the direction of groundwater flow may be affected locally by subsurface alluvial channels present within the underlying UMCf, the onsite bentonite-slurry groundwater barrier wall and by the hydraulic influence of the groundwater extraction wells at the three groundwater recovery well fields (Northgate, 2010b). The monitoring wells around the proposed pilot test location were removed during the 2010/2011 soil excavation so

the depth to groundwater can only be estimated. Based on water levels taken at M-111a in 2010 and groundwater contouring in Figure 6, the approximate depth to groundwater is 22 feet bgs.

4.4 Perchlorate in Groundwater

Perchlorate concentrations in the Shallow Zone vary across the Site. Based on August 2012 perchlorate analytical results (ENVIRON, 2012b), the highest perchlorate concentrations detected were:

- South of the barrier wall (i.e., in groundwater upgradient from the GWETS): 2,200 milligrams per liter (mg/L) (well I-AR);
- North of the barrier wall: 1,300 mg/L (M-72);
- North of the former recharge trenches: 700 mg/L (M-44);

From the isoconcentration map provided in Figure 7, concentrations of perchlorate in groundwater in the area of the proposed soil flushing pilot location are estimated to range between approximately 250 mg/L and 500 mg/L.

5 Preliminary Field Testing

Prior to implementation of the pilot test, additional data necessary to complete the pilot-scale design, and to operate and monitor the pilot system will be collected.

5.1 Permeameter Testing

A constant head permeameter will be utilized to determine the saturated hydraulic conductivity of the soils above the water table in the proposed pilot test location. Saturated hydraulic conductivity information will be used to determine the application or dosing rate that can be used for the pilot cell and to size the water conveyance system. A review of soil borings in the pilot test area indicate that stratified layers exist in the subsurface that may have a wide range of saturated hydraulic conductivity (K_{sat}) values. Therefore, the permeameter tests will be conducted at multiple depths within the vadose zone to quantify the K_{sat} at varying depths of the vadose zone soils.

Permeameter testing will be conducted using a 2840K2 Aardvark Permeameter following the methods provided for in the Standard Operating Procedure (SOP) included in Appendix B. Tests are planned to be run at depths of 1, 5, 10, 15, and 20 feet bgs at four locations within the proposed pilot test area. To create the borehole necessary to conduct the testing at the various depths, soil borings will be advanced using a Mini Sonic drilling rig and soils will be logged by an experienced ENVIRON field geologist. Based on conditions encountered, additional permeameter tests may be run if significant differences in lithology are observed.

5.2 Flushing Fluid Characterization

ENVIRON proposes using effluent from the GWETS as the flushing fluid in the pilot soil flushing system. Previous work plans have suggested using stabilized Lake Mead water, and this fluid was used in the Prima column study. However, given the high solubility of perchlorate, GWETS effluent is expected to be equally effective at flushing perchlorate from the vadose zone and could provide a more cost-effective and sustainable alternative for full-scale application.

One concern with using GWETS effluent is the potential to stimulate microbial growth and reduce the porosity of the soil. To determine the suitability of using GWETS effluent, ENVIRON will monitor the GWETS effluent prior to its application to the test area. Specifically, the monitoring program outlined in Table 1 will be implemented for the duration of the pilot study. Samples will be collected from the soil flushing surge tank following the procedures outlined in Appendix B.

6 Preliminary Pilot System Design & Operation

The following section discusses the preliminary design and operation of the pilot system based on site-specific data collected and reported to date. Pilot operations will need to be reassessed based on the results of the preliminary field activities.

In preparation of this preliminary design, ENVIRON considered various methods of applying flushing fluids for the pilot program including application of fluids at the ground surface under constant head within a bermed area and injection of fluids below ground surface via injection galleries (e.g., perforated piping, drip irrigation hose) or trenches. In the case of subsurface application of flushing fluids, excavation for installation would be necessary to install the system. If applied at the Site in full-scale, this type of system could involve considerable excavation and handling of contaminated soils. Consequently, it was determined that a subsurface system likely would entail significantly greater capital costs for construction due to increased requirements for soil management, air emissions monitoring, and general health and safety requirements. Accordingly, surface application was selected as the method of delivery of flushing fluids in the design of the pilot system.

6.1 Preliminary Design

Although a final detailed design cannot be established until additional data are collected, a preliminary design was completed using available data in order to determine approximate sizing and anticipated operational conditions and monitoring schedules during the pilot test. The primary design considerations relate to hydraulic loading, groundwater mounding, and impacts to the GWETS.

6.1.1 Flushing Volume

Determining the volume of water required to flush leachable perchlorate from the vadose zone soils is an objective of the pilot test, however for the purpose of the preliminary design an estimate was made using the previously collected column test information (Prima, 2010). The column testing determined that 99% of perchlorate was removed after approximately two pore volumes of flushing fluid were passed through the column. Additional water is likely necessary to achieve similar results in the field due to heterogeneities and the increased depth of contamination. Conservatively, a value of four pore volumes will be assumed for this exercise where a pore volume can be assumed using the surface area of the pilot flushing system and the depth to groundwater.

6.1.2 Hydraulic Loading

Hydraulic loading will be determined based on the saturated hydraulic conductivity determined by the permeameter testing described in Section 5.1. The soil horizon with the lowest saturated hydraulic conductivity will be used to calculate the infiltration rate for the pilot test. The infiltration rate can be calculated using the Green-Ampt equation (Green, W.H. and G. Ampt, 1911):

$$f_p = \frac{K_{sat}(H + S_f + L)}{L}$$

Where:

f_p = The infiltration rate

K_{sat} = Saturated soil conductivity

H = Recharge basin head at discharge point

S_f = Suction (capillary) head at wetting front = .97 to 25.36 cm for sands

L = Depth to wetting front

The infiltration rate determined by this equation represents the maximum infiltration rate that may be expected for the pilot test. For the preliminary design of the pilot cell presented herein, the maximum infiltration rate was estimated in the infiltration calculations of Appendix C to be 0.86 ft/day. The hydraulic loading will be determined using the infiltration rate and the area of the infiltration basin.

6.1.3 Groundwater Mounding

The saturated soil conductivity represents the maximum infiltration rate that can be achieved under saturated conditions; however the actual infiltration rate will be dependent on the potential for groundwater mounding. Mounding is of potential concern due to the operation of the soil flushing system in an area where the groundwater table is relatively shallow and horizontal hydraulic conductivities are high. Mounding inhibits vertical movement of water through the flushing zone and can lead to the flushing fluids moving horizontally before mixing with groundwater. Minimal amounts of mounding should not be an issue; however control of such mounding should be exercised.

AQTESOLVE software was used to estimate the extent of mounding based on the hydraulic conductivity, the infiltration rate, the expected duration of the pilot test, and the size of the pilot flushing area. Physical and hydraulic information gathered during the 2012 Capture Zone Evaluation Report (Northgate, 2010d) were used as inputs for the initial design. Mounding calculations are estimates and are only used to determine the necessity for in field monitoring. The data used and details of the calculations are provided in Appendix C.

Based on the proposed location of the pilot system and the extent of the IWF (Figure 5), the pilot is located approximately 300 feet from the edge of the projected capture zone. The results from the mounding analysis provided in Appendix C indicate that the pilot has the potential to create mounding that could potentially extend beyond the limits of the projected capture zone of the interceptor well field. As is discussed further in Section 6.2, based on the results of the mounding calculations presented in Appendix C, a pilot area size of 100 feet by 100 feet and a flow rate of approximately 4 gallons per minute (0.86 ft/day) were estimated. It is noted that both the dimensions of the pilot cell and the infiltration rates calculated in Appendix C are estimates. The final dimensions of the pilot cell will be based on in-field permeability testing, and mounding will be monitored during operation of the pilot. To this end, piezometers will be installed as discussed in Section 7.3 to monitor mounding, and to understand the effects of different flushing flow rates on the potential for mounding.

6.1.4 Potential Impacts to the GWETS

Operation of the soil flushing system will accelerate leaching of contaminants from soil to groundwater. In turn this has the potential to affect the contaminant loading to the GWETS. The degree of loading to the GWETS could be affected based on a number of variables including, but not limited to, the mass of perchlorate in the soils of the proposed soil flushing pilot area, the rate at which the perchlorate present in the soils leaches, and attenuation of perchlorate (e.g., retardation, attenuation, dispersion and dilution) between the pilot cell and the affected interceptor wells.

Wells installed to monitor the soil flushing pilot system and nearby downgradient interceptor well I-AR will be sampled during the operation of the pilot system to monitor the concentration of perchlorate and loading to the GWETS. If necessary, the rate of soil flushing will be adjusted to ensure loading to the treatment system remains within operational limitations.

6.2 Water Delivery System Operation

The proposed pilot soil flushing system will be installed and operated as a surface infiltration basin. Water will be distributed to the subsurface by flooding the pilot area to create a uniform hydraulic head across the pilot cell that will drive infiltration.

Pending the results of the permeameter testing, the preliminary sizing of the pilot test area is estimated to be approximately 100 feet by 100 feet. The area will be enclosed by an earthen berm with interior berms to divide the area into four 50 feet by 50 feet cells. This configuration will provide the flexibility to adjust the hydraulic loading to the pilot cell and will provide information on the effects that pilot system size and orientation have on subsurface flow and groundwater mounding. The berms will be constructed from clean fill, compacted and graded with 3:1 side slopes with a 1 foot top-of-berm width. The pilot cell berms will be high enough to provide at least six inches of freeboard above the high water level inside the berm. The entire pilot area will be covered with a vapor barrier (e.g., HDPE or similar liner) to limit evaporation losses from the pilot cell.

GWETS effluent water will be used as the flushing fluid for the pilot test. Effluent water from the GWETS will be supplied by installation of a connection at the discharge from the final effluent tank. The supply line will include a surge tank, check valve, a shutoff valve, a pump with controls, inline filter, air vents to drain the lines during shutdown, a pressure indicator, a flow meter with data logger, and flow control valve for each infiltration cell. The supply line will branch and discharge into each of the bermed pilot test cells; rip-rap or a similar velocity dissipation device will be installed around the discharge point to slow water flow and prevent erosion.

Flow into the pilot area will be controlled as follows. To prevent overflow of the berms of the pilot cell, a float switch or similar control device will be installed that will automatically cease flow into the pilot cell if a high level set point is reached, and will re-initiate flow once a low level set point is reached. To control the degree of mounding above the groundwater table, a control device will be installed to turn off flow based on the water level measured by an in-well transducer installed in one of the piezometers used to monitor the pilot cell. To provide flexibility in operations (e.g., pulsed application), the pilot system will be configured with a timer on the

water supply from the surge tank. A flow diagram for the pilot flushing system is provided in Figure 8. The exact equipment, specifications, and layout will be provided in a pilot design document.

6.3 Time to Complete Pilot Test

As discussed in Section 6.1.1 above, it is estimated that up to four pore volumes of water may be necessary to flush perchlorate from the soils during the pilot operations. Based on the size of the pilot test area and the estimated application rate predicted in the infiltration calculations of Appendix C, a minimum of 5 months is estimated to flush the soils. This time frame may vary based on the actual application rate that may be attained during testing and other site-specific conditions (e.g., subsurface anisotropies). Accordingly and for planning purposes the duration for soil flushing operations for the field-scale pilot is estimated to be 6 months. A preliminary time schedule for implementation of the soil flushing treatability study is provided in Section 9.

6.4 Permitting

The currently proposed soil flushing pilot system would involve the application of flushing water at the ground surface. Pursuant to Nevada Revised Statute (NRS) [445A.485] for construction and operation of the in-situ soil flushing pilot test ENVIRON proposes to apply for a temporary Groundwater Discharge Permit with the NDEP Bureau of Water Pollution Control. The Nevada statutes stipulate that such temporary permits may be issued for a maximum of a 180 day (6 month) period of time, which would cover the expected duration of the pilot test. The application for a temporary permit requires the following information to be provided:

1. A narrative description of the site and activities that require the discharge permit.
2. Results of water quality analysis by a Nevada State Certified Lab to include the potential contaminants/pollutants in the discharge.
3. The estimated quantity of discharge flow (e.g., gallons per day).
4. A topographic map and a site map showing the location of the potential discharge and a line drawing showing the general route taken by water in the facility from intake to discharge.
5. A listing of existing environmental permits at the facility.

Full-scale application of soil flushing, installation and operation of such a system may be permitted under a Modification to the existing NDEP Groundwater Discharge Permit (Permit No. NEV2001515) (NDEP, 2011) for the on-site ponds, AP-5 and GW-11, at the Site. Whether such a modification would be major or minor is yet to be determined.

7 Pilot System Monitoring

7.1 Leachate Monitoring

Pore water samples will be collected during the pilot test period to assess mass removal, to assess the number of pore volumes required to flush Site vadose zone soils, and to establish a correlation between leachate and soil perchlorate concentrations in order to streamline full scale system monitoring. Pore-water samples will be collected using the 1920F1 Pressure/Vacuum Soil Water Sampler. Four pore-water monitoring nests will be installed in the permeameter test borings within the pilot test footprint at the locations shown in Figure 9.

Each nest will consist of three lysimeters installed to depths of approximately 6, 12 and 20 feet bgs. If caliche is encountered at a pore-water monitoring location, then the installation depths of the lysimeters may be adjusted so that lysimeters are situated above and below the caliche to help determine the effects of this material on the performance of the pilot system. Each lysimeter will be installed in its own, separate boring spaced approximately two feet apart; PVC casing will be installed from the lysimeter to the ground surface to protect the sampler and tubing.

Pore water samples will be obtained from the four newly installed lysimeter nests using methods and instruments provided for in Soil Moisture Equipment Corp's *1921F1/1920F1K1 Operating Instructions* (Appendix B). The amount of pore water collected will vary according to conductivity of the soil, suction within the soil, and amount of vacuum within the sampler. Pore-water will be collected once the soil becomes saturated and every other day thereafter. After completion of the pilot test, pore water samples will continue to be collected bi-weekly for two weeks.

Pore water samples will be analyzed for the parameters listed in Table 1. The analytes are listed by priority in the case that the total volume of pore water in the sampler is less than the total volume of pore water needed for analysis. As stated in Section 1.2 above, the results of leachate monitoring will be used to assess the performance of the pilot system to reduce the mass of perchlorate in soils and thereby reduce the potential for perchlorate impacts to groundwater.

7.2 Soil

Soil samples will be collected before and after the pilot test to assess the change in vadose zone soil perchlorate concentrations. Soil samples will be collected at 0, 5, 10, 15 and 20 feet bgs from the same boring used to install the 20 foot pore-water monitoring point in each quadrant of the pilot test area. Post-pilot soil samples will be collected from borings installed immediately adjacent to the pre-pilot test borings approximately two weeks after cessation of soil flushing or once all lysimeters are no longer collecting leachate from the subsurface. Soil samples will be analyzed for the constituents listed in Table 2. Soil cuttings will be described in the field and sampled by an experienced ENVIRON field geologist following the procedures in Appendix B.

The results of soil sampling will provide useful information as an indicator of the effectiveness of soil flushing as a treatment technology. Additionally, and although not a stated objective of the

soil flushing pilot as expressed in Section 1.2, the results of soil samples at the ground surface will provide information on the ability of soil flushing to reduce perchlorate concentrations below BCLs.

As indicated above, the results of lysimeter sampling will be used as the key parameter to gauge the performance of the soil flushing pilot system. Due to potential variability in subsurface conditions (e.g., due to anisotropies in the subsurface), the discrete nature of soil sampling and difficulties in reproducing results, the results of soil sampling are not proposed as a strict indicator of performance for the soil flushing pilot, but rather as an additional line of evidence supporting the assessment of system effectiveness.

7.3 Groundwater Monitoring

Groundwater monitoring will be conducted to assess the influence of soil flushing on groundwater quality and the rate of application of flushing water on groundwater mounding. Four new groundwater monitoring wells – three downgradient and one upgradient – will be installed to monitor changes in groundwater quality (see Figure 9). Monitoring wells will be constructed of 2-inch inner diameter schedule 40 PVC with 10 feet of 0.01" slot screen. Groundwater samples will be collected before and after pilot operations and bi-weekly during pilot operations; this proposed frequency may be modified based on the results of the pore water samples. The parameters and associated analytical methods are provided in Table 1, and groundwater sampling procedures are provided in Appendix B.

Additionally, groundwater elevations will be monitored at five locations adjacent to and downgradient of the pilot location (see Figure 9) to assess the extent of groundwater mounding and the potential for lateral migration of groundwater induced by the pilot system. As discussed in Section 3, the groundwater table in the area of the pilot test is expressed at about 20 feet bgs within the UMCf formation. Previous investigations of the Site have indicated that the hydraulic conductivity of the UMCf is significantly less than the overlying alluvium within the Qal. Depending on the rate of application of flushing water during the pilot and mounding of groundwater within the Qal, an increase in potentiometric head expressed within the UMCf could occur. To monitor these conditions both a shallow piezometer, screened within the alluvium just above the Qal-UMCf interface, and a deep piezometer, screened within the UMCf just below the Qal-UMCf interface, will be installed at each location.

Piezometers will be nested within the same boring at each location, and constructed of 1-inch inner diameter schedule 40 PVC with 10 feet of 0.01" slot screen. Water levels at the first downstream piezometer nest will be monitored every hour using transducers with on-board data logging. As discussed in Section 6.1.3, the transducers will act as a control for the pilot system, shutting off water flow if water levels exceed the set point. Water levels at the other piezometers will be measured daily during pilot operations; results will be recorded in a field notebook and kept at the Site. Monitoring wells and piezometers will be installed following the procedures in Appendix B.

8 Reporting

A report detailing the results of the preliminary field testing as discussed in Section 5 and a final design for installation of the field-scale pilot system will be submitted 60 days after completion of field work. The report will include a description of the field activities conducted, a discussion of modifications or deviations from the work plan, results of the field work and the final design of the pilot test with drawings and specifications, and an implementation schedule.

9 Schedule

A preliminary schedule for the In-situ Soil Flushing Treatability Study is presented in Figure 10.

10 References

- ENVIRON 2012a. Interim Soil Removal Action Completion Report, August 2010 – November 2011. September 28.
- ENVIRON 2012b. Annual Remedial Performance Report for Chromium and Perchlorate, NERT Site, Henderson, Nevada, July 2011 – June 2012. August 31.
- ENVIRON 2012c. Revised April 2012 with May 2012 errata, Summary of Excavation Control Areas (ECAs): Areas of Known Soil Contamination left In-Place and Uncharacterized Potentially Contaminated Soils. December.
- ENVIRON 2012d. Revised April 2012 with May 2012 errata, Site Management Plan (SMP). April.
- Green, W.H. and G. Ampt. 1911. Studies of soil physics, part I – the flow of air and water through soils. *J. Ag. Sci.* 4:1-24.
- NDEP (Nevada Division of Environmental Protection) 2011. Groundwater Discharge Permit (Permit No. 2001515), Authorization to Discharge, Issued to Nevada Environmental Response Trust. July 10.
- Northgate (Northgate Environmental Management, Inc.) 2010a. Work Plan to Evaluate In-Situ Soil Flushing of Perchlorate-Impacted Soil. March 20.
- Northgate 2010b. Hydrogeologic Modeling Work Plan. April 29.
- Northgate 2010c. Revised Work Plan to Evaluate In-Situ Soil Flushing of Perchlorate-Impacted Soil. November 12.
- Northgate 2010d. Capture Zone Evaluation Report. December 10.
- Prima (Prima Environmental Inc) 2010. Report of Findings Column Tests to Evaluate In-Situ Flushing of Perchlorate. October 4.

Figures

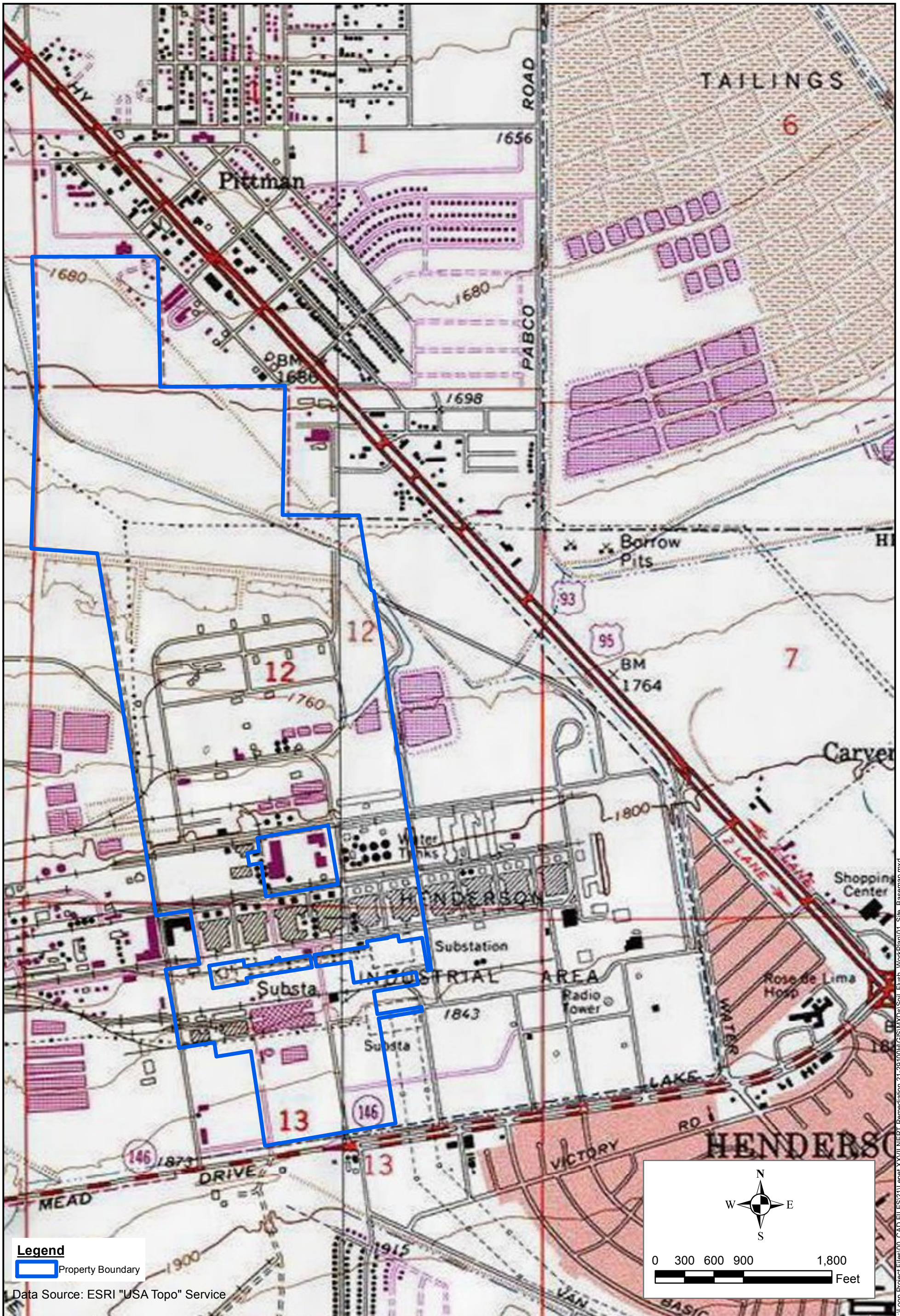

Legend
Property Boundary

Data Source: ESRI "USA Topo" Service

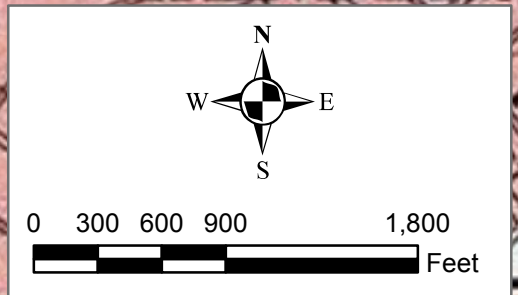

SITE LOCATION MAP

Nevada Environmental Response Trust Site, Henderson, Nevada

Figure
1

Drafter: CCS

Date: 12/7/2012

Contract Number: 21-29100H

Approved by: BSK/KKG

Revised:

L:\loop Project Files\00_CAD FILES\21\Leper\XXVII\NERI Remediation 21-29100\GIS\MXDS\Soil_Flush_WorkPlan\01_Site_Basemap.mxd



Legend

- Proposed Pilot Test Location
- Site Boundary
- Barrier Wall

Data Sources: ESRI 2010 Bing Imagery
 Projection: State Plane Coordinate System of 1983, Nevada East Zone

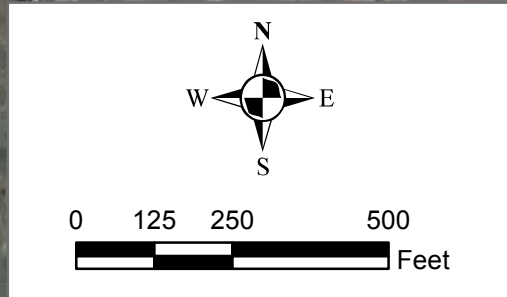

PROPOSED PILOT TEST LOCATION

Nevada Environmental Response Trust Site, Henderson, Nevada

Drafter: CCS

Date: 12/7/2012

Contract Number: 21-29100H

Approved by: BSK/KKG

Revised:

Figure

2



Perchlorate Concentrations at the Proposed Pilot Test Location
 Nevada Environmental Response Trust Site, Henderson, Nevada

Figure
3

Drafter: EA

Date: 12/14/2012

Contract Number: 21-29100

Approved by: BSK/KKG

Revised:



L:\Loop Project Files\00_CAD FILES\21\Lepeet XXVII NERT Remediation 21-29100H\GIS\MXD\Soil_Flush_WorkPlan04_UilitiesNearPilotTestSite.mxd

| | | | | |
|--|---|-----------------|----------------------------|----------|
| | UTILITIES NEAR THE PROPOSED PILOT TEST LOCATION Nevada Environmental Response Trust Site, Henderson, Nevada | | | Figure |
| | Drafter: CCS | Date: 12/7/2012 | Contract Number: 21-29100H | 4 |
| | | | Approved by: BSK/KKG | Revised: |

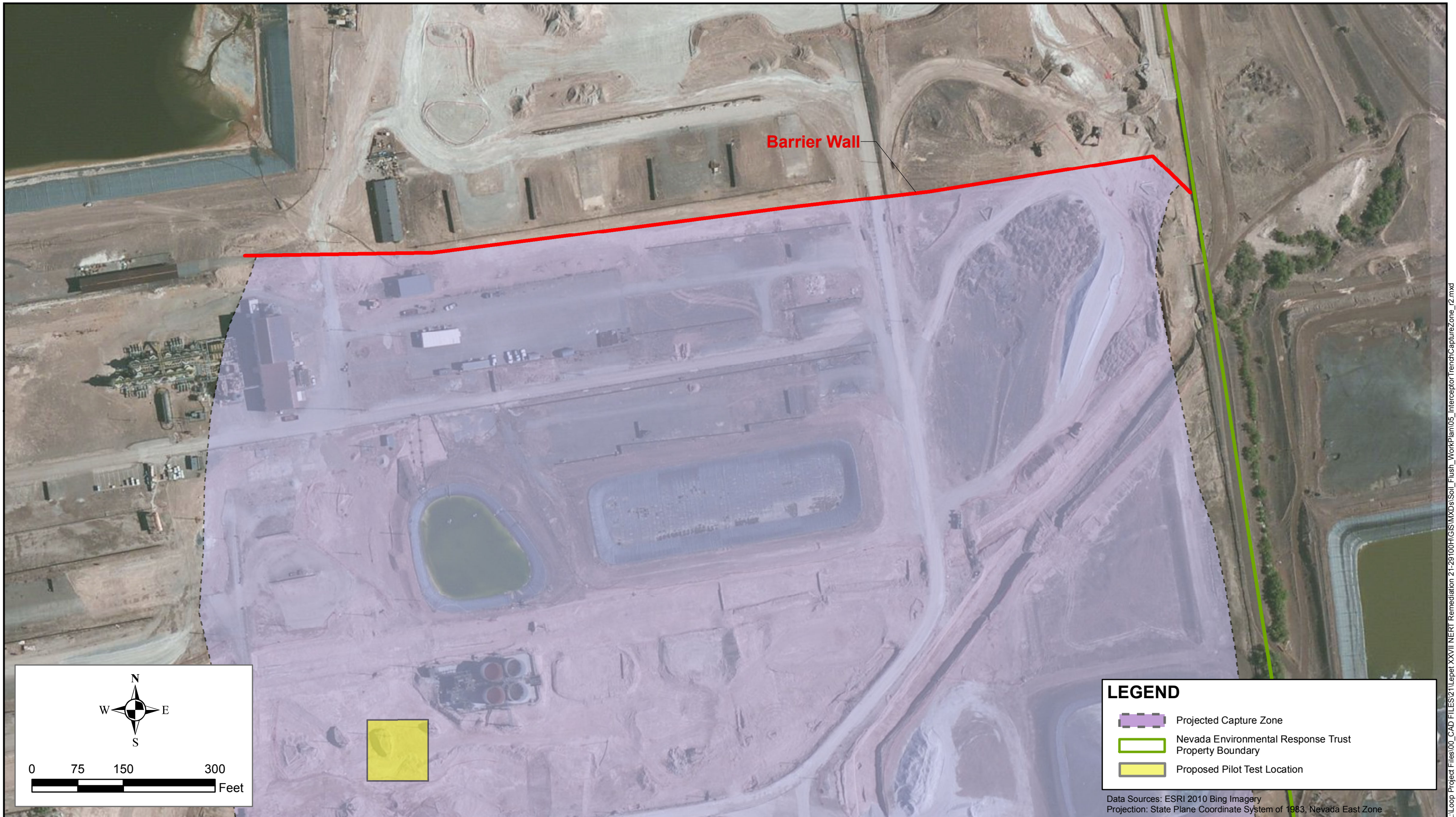

L:\Loop Project Files\00_CAD FILES\21\Lepe\21\Lepe\21\GIS\MXDs\Soil_Flush_WorkPlan\05_InterceptorTrench\CaptureZone_12.mxd



INTERCEPTOR TRENCH PROJECTED CAPTURE ZONE

Nevada Environmental Response Trust Site, Henderson, Nevada

Drafter: CCS

Date: 12/7/2012

Contract Number: 21-29100H

Approved by: BSK/KKG

Revised:

Figure

5

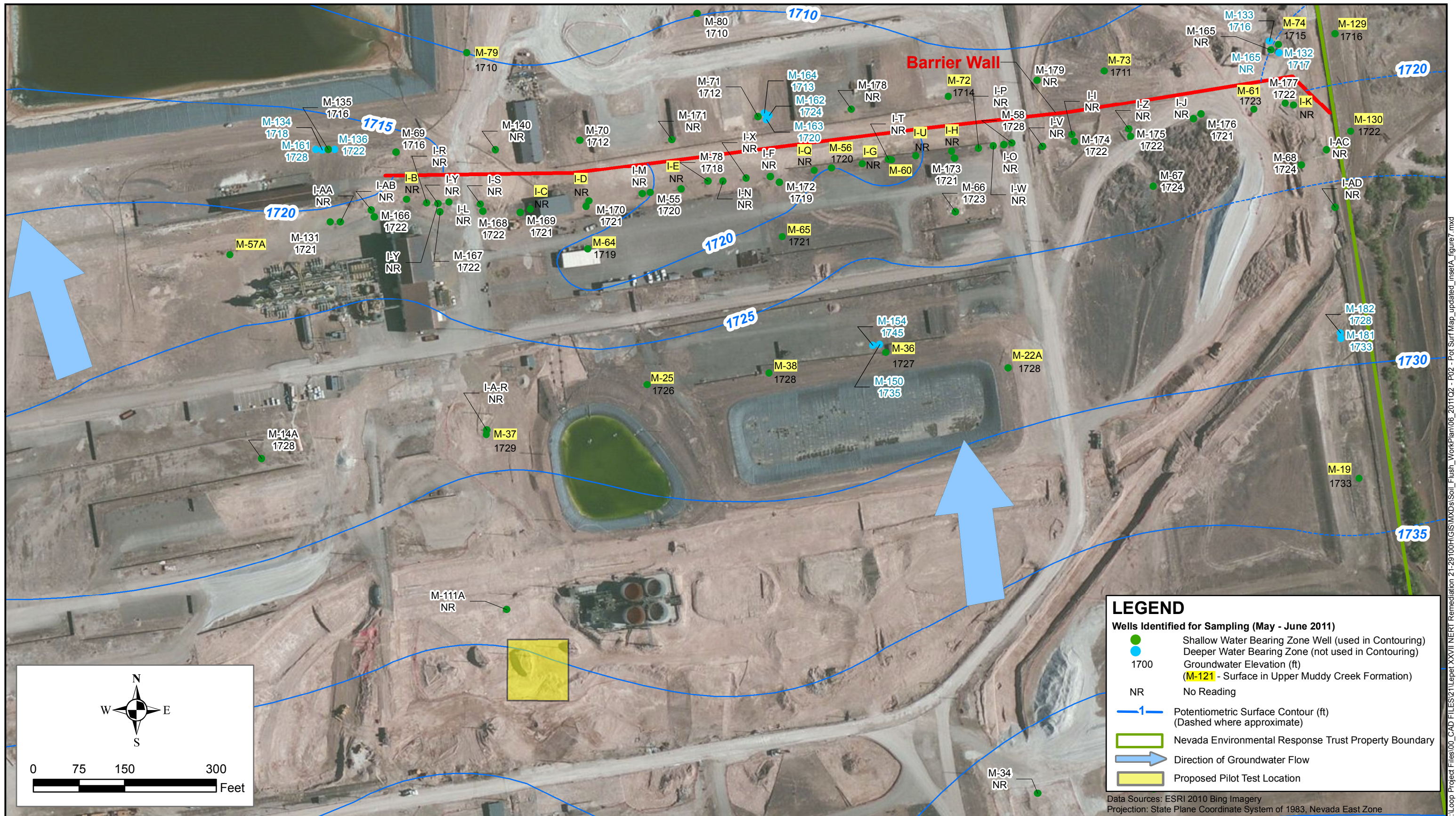

LEGEND

- Shallow Water Bearing Zone Well (used in Contouring)
- Deeper Water Bearing Zone (not used in Contouring)
- 1700 Groundwater Elevation (ft)
- (M-121) - Surface in Upper Muddy Creek Formation
- NR No Reading
- Potentiometric Surface Contour (ft) (Dashed where approximate)
- ▭ Nevada Environmental Response Trust Property Boundary
- ➔ Direction of Groundwater Flow
- ▭ Proposed Pilot Test Location

Data Sources: ESRI 2010 Bing Imagery
 Projection: State Plane Coordinate System of 1983, Nevada East Zone

L:\Loop Project Files\00_CAD FILES\21\Leper XXVII NERT Remediation 21-29100H\GIS\MXDs\Soil_Flush_WorkPlan\06_2011\02 - P02 - Pot Surf Map_updated_insetA_figure7.mxd

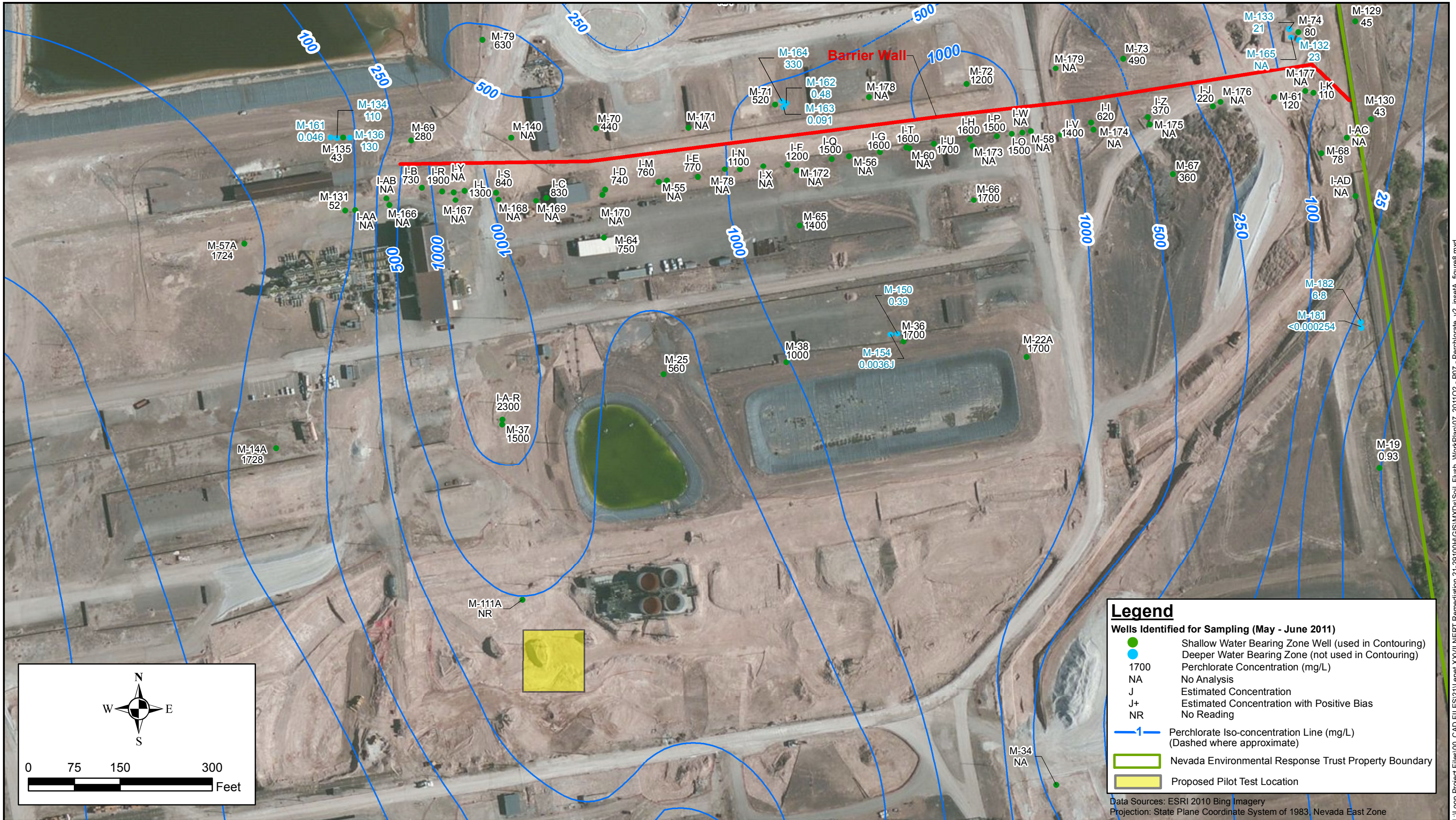

L:\Loop Project Files\00_CAD FILES\21\Leper_XXVII NERT Remediation 21-29100H\GIS\MXDs\Soil_Flush_WorkPlan\07_2011\02 - P07 - Perchlorate_v2_insetA_figure8.mxd



PERCHLORATE CONCENTRATIONS IN GROUNDWATER NEAR THE PROPOSED PILOT TEST LOCATION
Nevada Environmental Response Trust Site, Henderson, Nevada

Figure
7

Drafter: MI

Date: 12/7/2012

Contract Number: 21-29100H

Approved by: BSK/KKG

Revised:

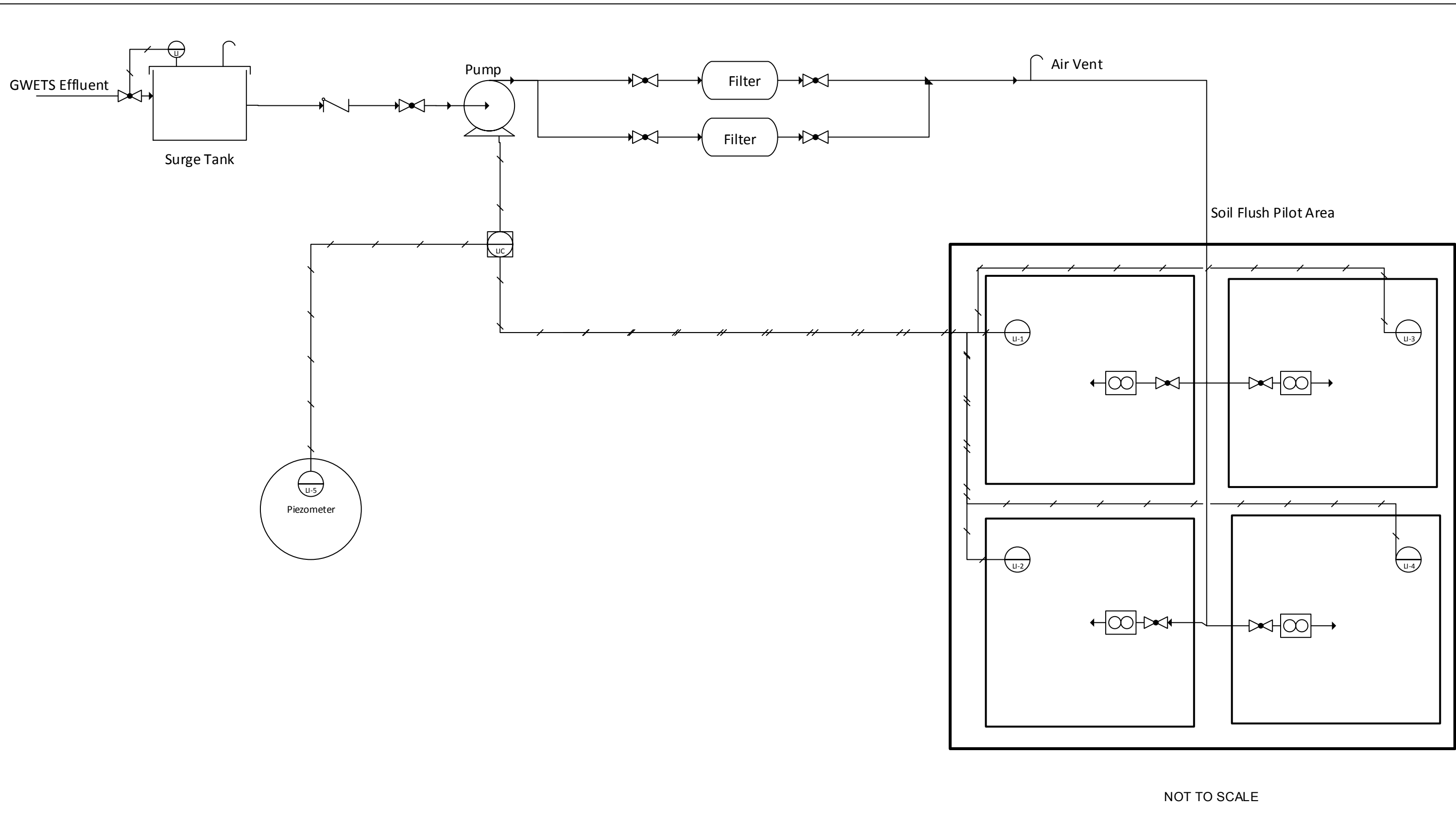

NOT TO SCALE



PROPOSED SOIL FLUSH PILOT TEST PROCESS FLOW LAYOUT
 Nevada Environmental Response Trust Site, Henderson, Nevada

Drafter: FN

Date: 12/7/2012

Contract Number: 21-29100H

Approved by: BSK/KKG

Figure
8

L:\Loop Project Files\00_CAD FILES\21\Leper\XXVII NERT Remediation 21-29100H\Isol\08_NERT Soil Flush.vsd

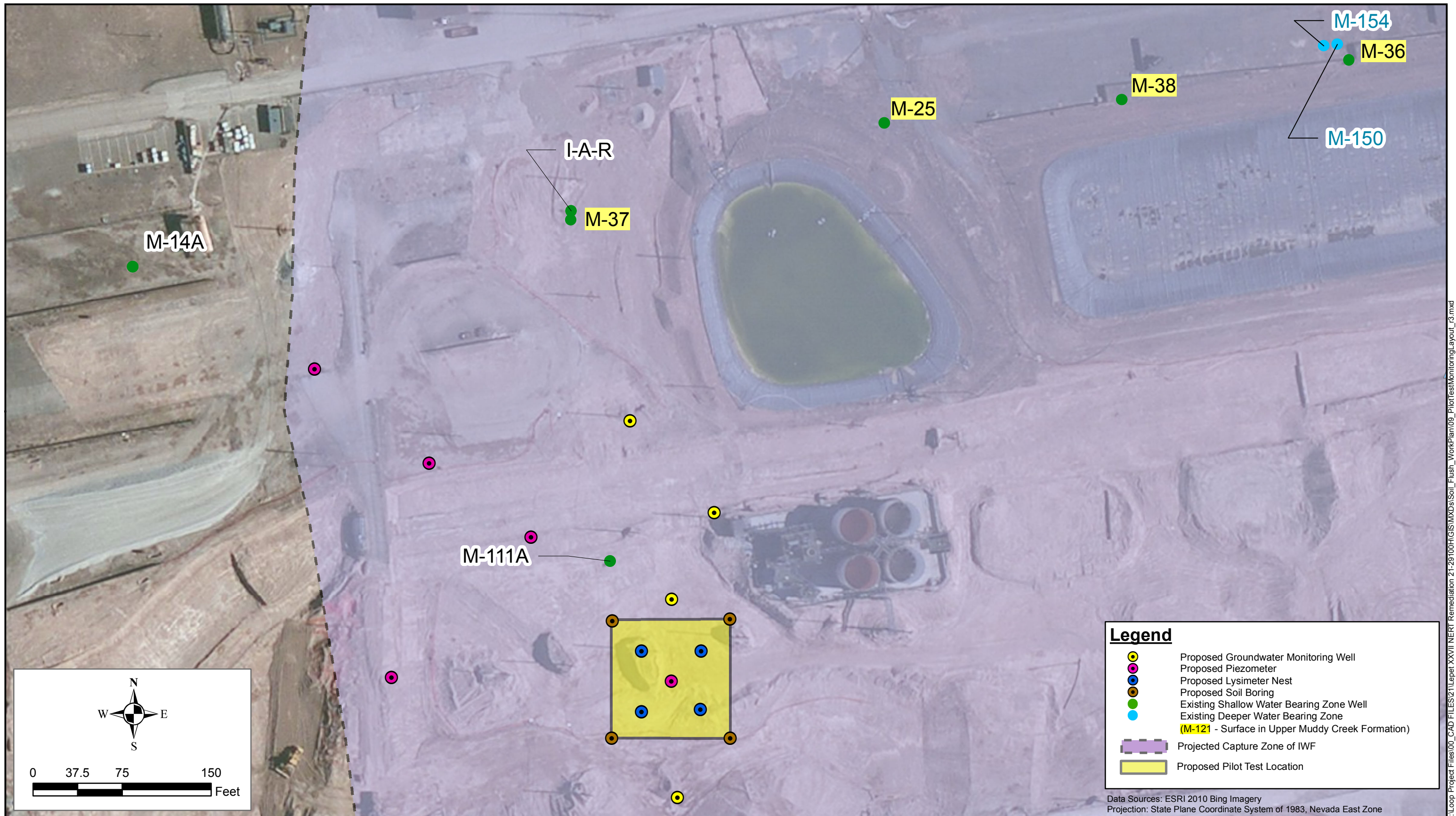

Legend

- Proposed Groundwater Monitoring Well
- Proposed Piezometer
- Proposed Lysimeter Nest
- Proposed Soil Boring
- Existing Shallow Water Bearing Zone Well
- Existing Deeper Water Bearing Zone
- (M-121 - Surface in Upper Muddy Creek Formation)
- Projected Capture Zone of IWF
- Proposed Pilot Test Location

Data Sources: ESRI 2010 Bing Imagery
 Projection: State Plane Coordinate System of 1983, Nevada East Zone



PILOT TEST MONITORING LAYOUT - SOIL FLUSHING TREATABILITY STUDY
 Nevada Environmental Response Trust Site, Henderson, Nevada

Drafter: CCS Date: 12/7/2012 Contract Number: 21-29100H Approved by: BSK/KKG Revised:

Figure
9

L:\Loop Project Files\00_CAD FILES\21\Leper XXVII NERT Remediation 21-29100H\GIS\MXD\Soil_Flush_WorkPlan\09_PilotTestMonitoringLayout_r3.mxd

Figure 10. Preliminary Time Schedule for In-situ Soil Flushing Treatability Study

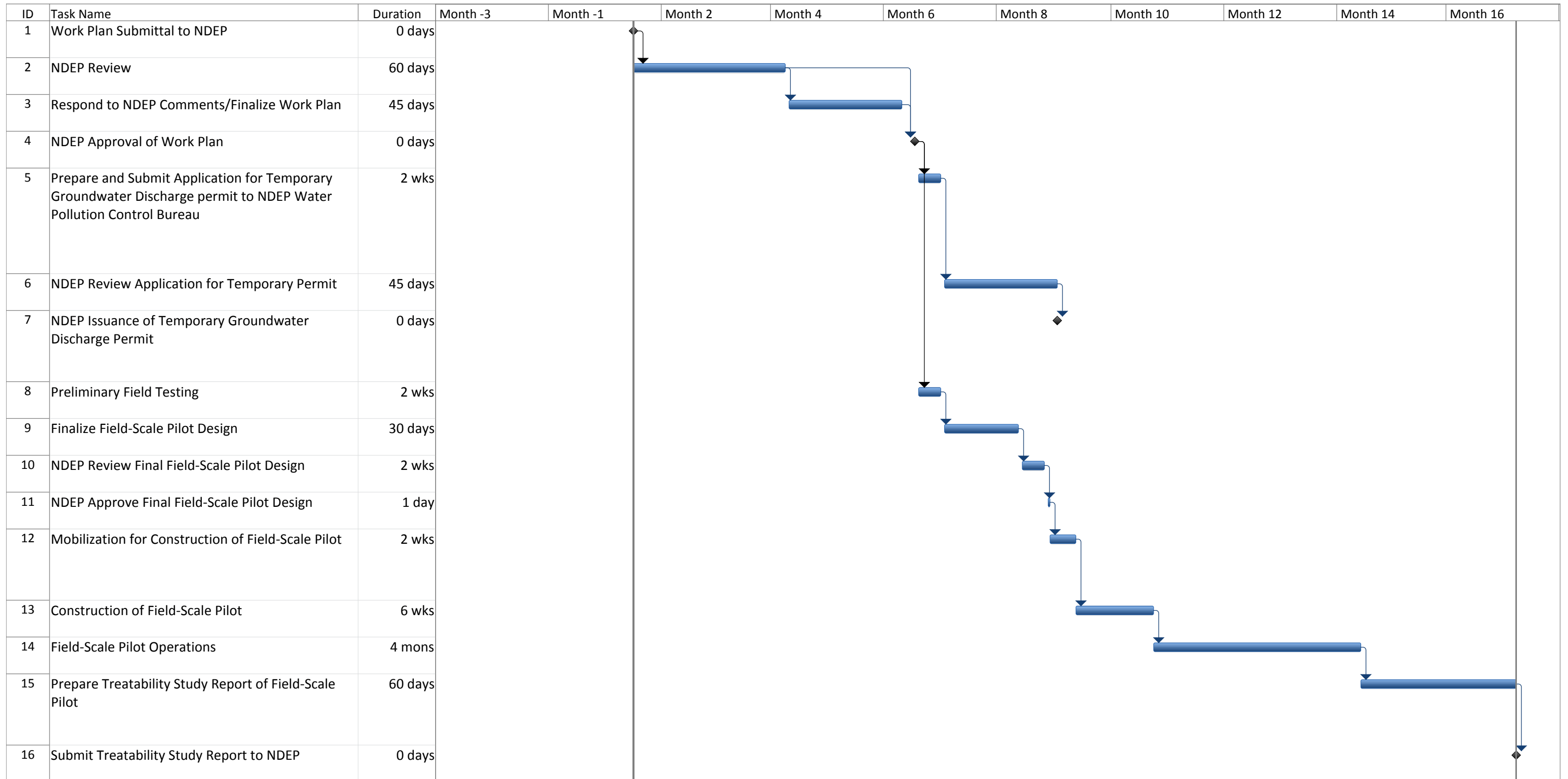

| | | | | | | | | | |
|-----------|--|--------------------|--|--------------------|--|-----------------------|--|----------|--|
| Task | | Project Summary | | Inactive Milestone | | Manual Summary Rollup | | Deadline | |
| Split | | External Tasks | | Inactive Summary | | Manual Summary | | Progress | |
| Milestone | | External Milestone | | Manual Task | | Start-only | | | |
| Summary | | Inactive Task | | Duration-only | | Finish-only | | | |

Tables

TABLE 1
Water Sample Analytes and Methods -
Treatability Study Work Plan,
In-Situ Soil Flushing

| Analyte | Volume (mL) | USEPA Method | Frequency ¹ | Priority ² |
|---|-------------|---------------------|--|-----------------------|
| Perchlorate | 125 | 314 | Start-up and Bi-weekly | 1 |
| Conductivity, DO, pH, ORP | 50 | Portable Instrument | | 2 |
| TDS | 125 | 160.1 | | 3 |
| TSS | 125 | 160.2 | | 4 |
| Dissolved Metals (Ag, As, B, Ba, Be, Ca, Cd, Cr, Co, Cu, Fe, Hg, K, Mo, Mg, Mn, Na, Ni, Pb, Sb, Se, Ti, Zn) | 100 | 6010/6020/7400 | Start-up and Weekly during pilot operation | 5 |
| Cr(VI) | 50 | 7199 | | 6 |
| TOC | 80 | 9060 | | 7 |
| Anions (Br, Cl, ClO ₃ , F, NO ₃ , NO ₂ , SO ₄) | 125 | 9056 | | 8 |
| Sulfite | 500 | 377.1 | | 9 |
| Ferrous Iron (Fe+2) | 100 | Field Kit | | 10 |
| Alkalinity (Total, HCO ₃ , Hydroxide) | 500 | 310.2 | | 11 |
| Hardness (total) | 250 | 130.1 | | 12 |
| Ammonia | 500 | 350.1 | | 13 |
| Phosphate | 125 | 365.1 | | 14 |
| Dissolved Metals (U) | 100 | 200.8 | | 15 |
| Chloroform (VOCs) | 120 | 8260B | Start-up | 16 |
| Organochlorine Pesticides + Hexchlorobenzene | 250 | 8081A | | 17 |

Notes:

1. If constituents are repeatedly not detected, then the frequency of analysis may be reduced.
2. All analytes to be run if sufficient sample volume is available. Priorities apply only in the event that insufficient volume is available to run all analyses.

TABLE 2
Soil Sample Analytes and Methods -
Treatability Study Work Plan,
In-Situ Soil Flushing

| Analyte | USEPA Method |
|-----------------------------|------------------|
| Hexavalent Chromium, Cr(VI) | 7190A/7199/3060A |
| Metals | 6010/6020 |
| Perchlorate | 314/6850 |
| pH | 9045 |

Appendix A

Boring Logs and Well Construction Diagrams

SOIL BORING LOG KM-5055A

| KERR-McGEE CORPORATION Hydrology Dept. Engineering Services | | KM SUBSIDIARY KMCLLC | LOCATION HENDERSON, NV | | BORING NUMBER M-14A | | | | | |
|--|--|-------------------------|---------------------------|----------------|------------------------|-------------|------|-------|------|-------------------------------|
| DEPTH IN FEET | LITHOLOGIC DESCRIPTION | GRAPHIC LOG | UNIFIED SOIL FIELD CLASS. | BLOWS PER FOOT | PID (PPM) | SOIL SAMPLE | | | | REMARKS OR FIELD OBSERVATIONS |
| | | | | | | NO. | TYPE | DEPTH | REC. | |
| 0-20 | SAND, gravelly w/ 10-20% silt, brn. 50% v.f. vc sand, sh- SA 30-40% volc gravel to 1" diam 10-20% silt | | SW/ SM | | | | | | | |
| 20-28 | SAND, silty, brn. 30-40% silt in v.f. mg sand matrix | | SM ML | | | | | | | Jump @ 23 wlt @ 28 |
| 28-40 | CLAY, silty brn. 30-40% silt in clay matrix | | CL | | | | | | | MC @ 28' |

| | | | | | | |
|-------------|---|---------------------------|-------------------------------------|-----------------|----------|--|
| EXPLANATION | Water Table (24 Hour) | GRAPHIC LOG LEGEND | | DATE DRILLED | PAGE | |
| | Water Table (Time of Boring) | CLAY | DEBRIS FILL | 12-7-04 | 1 of 1 | |
| | PID NO. TYPE Identifies Sample by Number Sample Collection Method | SILT | HIGH ORGANIC (PEAT) | DRILLING METHOD | HSA | |
| | SPLIT-BARREL | AUGER | SANDY CLAY | DRILLED BY | TENV | |
| | THIN-WALLED TUBE | CONTINUOUS SAMPLER | CLAYEY SAND | LOGGED BY | ED KRISH | |
| ROCK CORE | NO RECOVERY | SAND | EXISTING GRADE ELEVATION (FT. AMSL) | 1758.30 | | |
| GRAVEL | | SILTY CLAY | LOCATION OR GRID COORDINATES | | | |
| CLAYEY SAND | | CLAYEY SILT | | | | |
| DEPTH REC. | Depth Top and Bottom of Sample Actual Length of Recovered Sample in Feet | | | | | |

KERR-McGEE CORPORATION
HYDROLOGY DEPARTMENT
MONITORING WELL INSTALLATION DIAGRAM

Protective Pipe: Yes No
 Steel PVC
 Surveying Pin? Yes No
 Casing Cap Vent? Yes No
 Lock? Yes No
 Weep Hole? Yes No
 Concrete Pad: 1 Ft. x 1 Ft. x 4 Inches

DRILLING INFORMATION:
 1. Borehole Diameter = 8 Inches.
 2. Were Drilling Additives Used? Yes No
 Revert Bentonite Water
 Solid Auger Hollow Stem Auger
 3. Was Outer Steel Casing Used? Yes No
 Depth: 0 Feet.
 4. Borehole Diameter for Outer Casing: _____ Inches.

WELL CONSTRUCTION INFORMATION:
 1. Type of Casing: PVC Galvanized Teflon
 Stainless Other _____
 2. Type of Casing Joints: Screw-Couple Glue-Couple Other _____
 3. Type of Well Screens: PVC Galvanized
 Stainless Teflon Other _____
 4. Diameter of Casing and Well Screens: Casing 2 Inches, Screen 2 Inches.
 5. Slot Size of Screens: 0.020
 6. Type of Screen Perforation: Factory Slotted
 Hacksaw Drilled Other _____
 7. Installed Protector Pipe w/ Locks: Yes No

WELL DEVELOPMENT INFORMATION:
 1. How was Well Developed? Bailing Pumping
 Air Surging (Air or Nitrogen) Other SURGE BLOCK/AIR LIFT
 2. Time Spent on Well Development? 4 Minutes/Hours
 3. Approximate Water Volume Removed? 75 Gallons
 4. Water Clarity Before Development? Clear
 Turbid Opaque
 5. Water Clarity After Development? Clear
 Turbid Opaque
 6. Did Water have Odor? Yes No
 If Yes, Describe _____
 7. Did Water have any Color? Yes No
 If Yes, Describe _____

WATER LEVEL INFORMATION:
 Water Level Summary (From Top of Casing)
 During Drilling: 28 Ft. Date 12-7-04
 Before Development: _____ Ft. Date _____
 After Development: 28.50 Ft. Date 12-7-04

Driller/Firm: TENV Drill Rig Type: Mobile B-61 Date Installed: 12-7-04
 Drill Crew: SHIM/KENT/RICK Well No.: M-14A Hydrologist: ED KRISH (ENSR)

920
901
-02
for
W
Kerr
McGee
68
ris
ere
Se
5
ion.
sing
de
tes
10,
rio
ut
tes

SOIL BORING LOG KM-5655-8

| KERR-McGEE CORPORATION Hydrology Dept. - S&EA Division | | KM SUBSIDIARY KMC LLC | | LOCATION HENDERSON, NV | | BORING NUMBER M17A | | | | | |
|---|--|--------------------------|---------------------------|---------------------------|-----------|--|------|-------|------|---|--|
| DEPTH IN FEET | LITHOLOGIC DESCRIPTION | GRAPHIC LOG | UNIFIED SOIL FIELD CLASS. | BLOWS PER 6' | PID (ppm) | SOIL SAMPLE | | | | REMARKS OR FIELD OBSERVATIONS | |
| | | | | | | NO. | TYPE | DEPTH | REC. | | |
| 5 | 0-50 30-40% sand SAND 15-20% silt 20-30% m-vc sand 10-15% clay 10-15% m-vc sand 10-15% clay | | | | | | | | | | |
| 10 | | | | | | | | | | | |
| 15 | | | | | | | | | | | |
| 20 | | | | | | | | | | | |
| 25 | 20-33 silty sdy GRAVEL, brown, 20% silt, 20% m-vc sand 15-20% clay | | | | | | | | | | |
| 30 | | | | | | | | | | | |
| 33 | | | | | | | | | | Jump @ 32 | |
| 35 | 33-35 silty clay silt 14 brown, 10-15% clay 15-20% m-vc sand | | | | | | | | | mt @ 35 | |
| 37 | 35-39 calc. fr. sdy GRAVEL, hard, 80% gravel 20% m-vc sd. | | | | | | | | | | |
| EXPLANATION ▼ Water Table (24 Hour) ▽ Water Table (Time of Boring) PID Photoionization Detection (ppm) NO. Identifies Sample by Number TYPE Sample Collection Method ⊗ SPLIT-BARREL ▮ THIN-WALLED TUBE ▮ AUGER ▮ CONTINUOUS SAMPLER ▮ ROCK CORE ▮ NO RECOVERY DEPTH Depth Top and Bottom of Sample REC. Actual Length of Recovered Sample in Feet | | | | | | GRAPHIC LOG LEGEND [diagonal lines] CLAY [horizontal lines] SILT [dots] SAND [cross-hatch] GRAVEL [diagonal lines /] SILTY CLAY [diagonal lines \] CLAYEY SILT [stippled] DEBRIS FILL [wavy] HIGHLY ORGANIC (PEAT) [diagonal lines /] SANDY CLAY [diagonal lines \] CLAYEY SAND | | | | DATE DRILLED 6-18-03 PAGE 1 of 2 | |
| | | | | | | DRILLING METHOD HSA | | | | | |
| | | | | | | DRILLED BY ELITE DRILLING | | | | | |
| | | | | | | LOGGED BY ED KRISH | | | | | |
| | | | | | | EXISTING GRADE ELEVATION (FT AMSL) 1708.95 | | | | | |
| | | | | | | LOCATION OR GRID COORDINATES 1758.95 | | | | | |

SOIL BORING LOG KM-5655-B

| KERR-McGEE CORPORATION Hydrology Dept. - S&EA Division | | KM SUBSIDIARY <i>KMCLLC</i> | | LOCATION <i>HENDERSON, NV</i> | | BORING NUMBER <i>M17A</i> | | | | | |
|--|------------------------|--------------------------------|---------------------------|----------------------------------|-----------|---|------|-------|------|---|--------------------------------------|
| DEPTH IN FEET | LITHOLOGIC DESCRIPTION | GRAPHIC LOG | UNIFIED SOIL FIELD CLASS. | BLOWS PER 6" | PID (ppm) | SOIL SAMPLE | | | | REMARKS OR FIELD OBSERVATIONS | |
| | | | | | | NO. | TYPE | DEPTH | REC. | | |
| <div style="display: flex; justify-content: space-between;"> <div style="width: 45%; border-right: 1px dashed black; padding-right: 5px;"> <p><i>30-40</i> <i>fine to med. sand</i> <i>dk brn, v. m. of some</i> <i>mod. to med. clay</i></p> <p><i>40-45</i> <i>clay SILT</i> <i>mod. brn, 20-30% clay</i></p> </div> <div style="width: 5%; border-right: 1px dashed black;"></div> <div style="width: 45%; border-right: 1px dashed black;"></div> </div> | | | | | | | | | | | <p><i>no. 1</i></p> <p><i>ME</i></p> |
| EXPLANATION ▼ Water Table (24 Hour) ▽ Water Table (Time of Boring) PID Photoionization Detection (ppm) NO. Identifies Sample by Number TYPE Sample Collection Method [X] SPLIT-BARREL [] AUGER [] ROCK CORE [] THIN-WALLED TUBE [] CONTINUOUS SAMPLER [] NO RECOVERY DEPTH Depth Top and Bottom of Sample REC. Actual Length of Recovered Sample in Feet | | | | | | GRAPHIC LOG LEGEND [] CLAY [] DEBRIS FILL [] SILT [] HIGHLY ORGANIC (PEAT) [] SAND [] SANDY CLAY [] GRAVEL [] CLAYEY SAND [] SILTY CLAY [] _____ [] CLAYEY SILT [] _____ | | | | DATE DRILLED <i>6-18-03</i> PAGE <i>2 of 2</i> DRILLING METHOD <i>HSA</i> DRILLED BY <i>ELITE DRILLING</i> LOGGED BY <i>ED KRISH</i> EXISTING GRADE ELEVATION (FT. AMSL) LOCATION OR GRID COORDINATES | |

KERR-McGEE CORPORATION HYDROLOGY DEPARTMENT MONITORING WELL INSTALLATION DIAGRAM

FLOSH
MOUNT

Protective Pipe

Yes No

Steel PVC

Surveying Pin ?

Yes No

Casing Cap Vent ? Yes No

Lock ? Yes No

Weep Hole ? Yes No

Concrete Pad _____ Ft. x _____ Ft. x _____ Inches

Concrete

DEPTH
FROM
TOP OF
CASING
BELOW
GRADE

Cement/Bentonite Grout Mix

Yes No

5.5 Gallons Water to
94Lb. Bag Cement &
3-5 Lb. Bentonite
Powder

Other: _____

Bentonite Seal

Pellets Slurry

Filter Pack
Above Screen

FILTER PACK MATERIAL

Silica Sand

Washed Sand

Pea Gravel

Other: _____

Sand Size 12-20

Dense Phase Sampling Cup

Bottom Plug
Yes No

Overdrilled Material
Backfill

Grout Sand

Caved Material

Other: _____

DRILLING INFORMATION:

- Borehole Diameter = 9 Inches.
- Were Drilling Additives Used? Yes No
Revert Bentonite Water
Solid Auger Hollow Stem Auger
- Was Outer Steel Casing Used? Yes No
Depth = _____ to _____ Feet.
- Borehole Diameter for Outer Casing _____ Inches.

WELL CONSTRUCTION INFORMATION:

- Type of Casing: PVC Galvanized Teflon
Stainless Other _____
- Type of Casing Joints: Screw-Couple Glue-Couple Other _____
- Type of Well Screen: PVC Galvanized
Stainless Teflon Other _____
- Diameter of Casing and Well Screen:
Casing 2 Inches, Screen 2 Inches.
- Slot Size of Screen: .020
- Type of Screen Perforation: Factory Slotted
Hacksaw Drilled Other _____
- Installed Protector Pipe w/Locks: Yes No

WELL DEVELOPMENT INFORMATION:

- How was Well Developed? Bailing Pumping
Air Surging (Air or Nitrogen) Other _____
- Time Spent on Well Development ?
_____ / _____ Minutes/Hours
- Approximate Water Volume Removed ? _____ Gallons
- Water Clarity Before Development? Clear
Turbid Opaque
- Water Clarity After Development? Clear
Turbid Opaque
- Did Water have Odor? Yes No
If Yes, Describe _____
- Did Water have any Color? Yes No
If Yes, Describe _____

WATER LEVEL INFORMATION:

Water Level Summary (From Top of Casing)

During Drilling _____ Ft. Date _____
 Before Development 32.93 Ft. Date 6-19-03
 After Development _____ Ft. Date _____

Driller/Firm TECH/ELITE

Drill Rig Type CME 75

Date Installed 6-15-03

Drill Crew Tom / CHRIS

Well No. 1017A

Kerr-McGee
Hydrologist ED KEISH

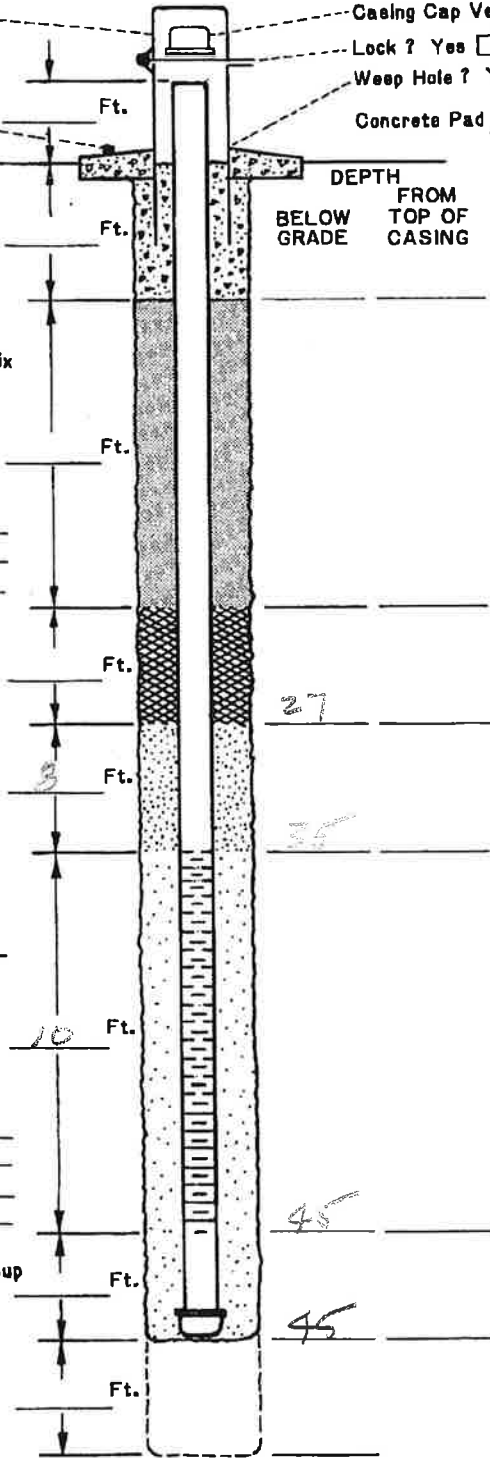

LOG OF WATER SAMPLE WELL 25

DATE 5/14/64

LOCATION KMCC, Henderson, NV

ELEVATION

| DEPTH IN FEET | SAMPLES SYMBOL | SOIL DESCRIPTION | COLOR | MOISTURE | CONSISTENCY | REMARKS |
|---------------|----------------|------------------|--------------------------|----------|-------------|---------|
| 0 | | | | | | |
| 2 | SW | GRAVELLY SAND | light brown | | | |
| 4 | | | | | | |
| 6 | | | | | | |
| 8 | | | | | | |
| 10 | | | | | | |
| 12 | | | | | | |
| 14 | | | | | | |
| 16 | | | | | | |
| 18 | | | | | | |
| 20 | SW/ GW | SAND & GRAVEL | light brown & dark brown | | | |
| 22 | | | | | | |
| 24 | | | | | | |
| 26 | | | | | | |
| 28 | | | | | | |
| 30 | CL | SILT & CLAY | | | | |
| 32 | | | | | | |
| 34 | | | | | | |
| 36 | | | | | | |
| 38 | | | | | | |
| 40 | | | | | | |

End of well at 40.0 ft.

THIS SUMMARY APPLIES ONLY AT THIS LOCATION AND AT THE TIME OF LOGGING. SUBSURFACE CONDITIONS MAY DIFFER AT OTHER LOCATIONS AND MAY CHANGE AT THIS LOCATION WITH THE PASSAGE OF TIME. THE DATA PRESENTED IS A SIMPLIFICATION OF ACTUAL CONDITIONS ENCOUNTERED.

DRAWING NO.

WELL CONSTRUCTION DIAGRAM
 WELL M-36
 HENDERSON, NEVADA

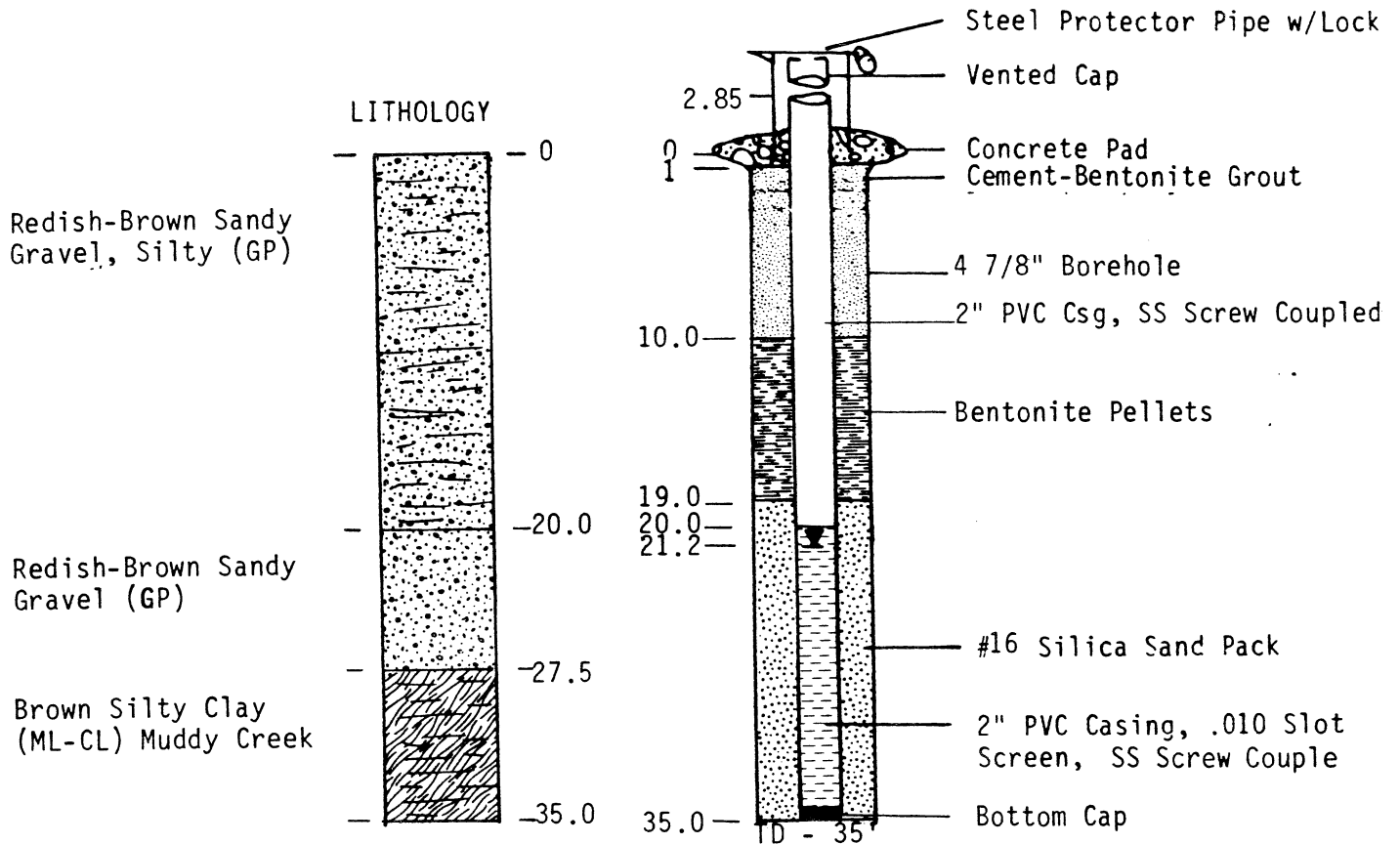

DATE DRILLED: 6/26/85
 DRILLED BY: Converse Cons.
 DRILLING METHOD: Rotary Wash-Water
 LOGGED BY: Bert Smith, Kerr-McGee
 CASING ELEVATION: 1758.88' MSL

WELL CONSTRUCTION DIAGRAM
 WELL M-38
 HENDERSON, NEVADA

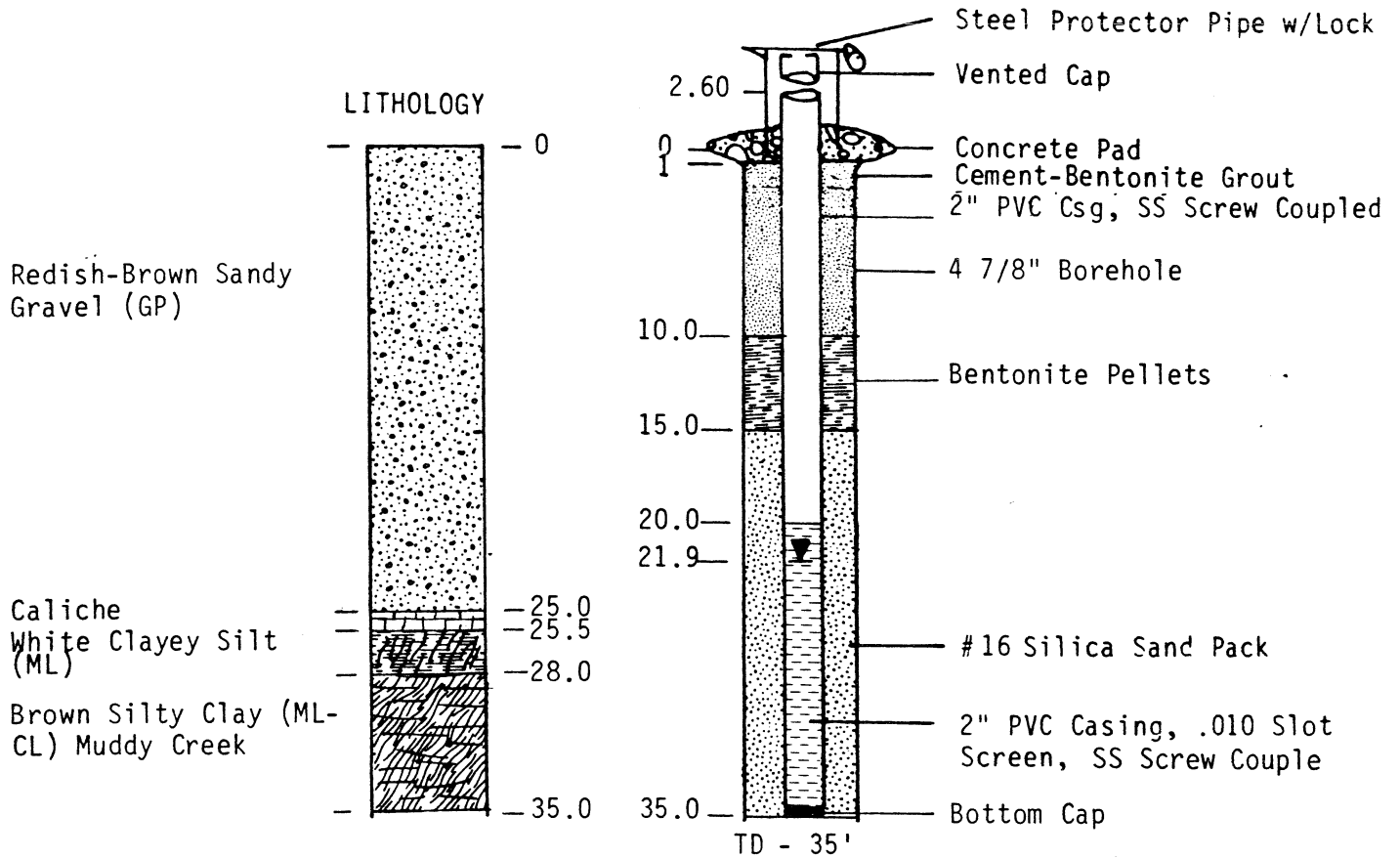

DATE DRILLED: 6/26/85
 DRILLED BY: Converse Cons.
 DRILLING METHOD: Rotary Wash - Water
 LOGGED BY: Bert Smith, Kerr-McGee
 CASING ELEVATION: 1759.08' MSL

ENSR
1220 Avenida Acaso
Camarillo, CA 93012
(805)388-3775

Client: Tronox LLC
Project Number: 04020-023-160
Site Description/Location: 500' South of Interceptor Well Field, Henderson, NV
Coordinates: Not Surveyed Elevation:
Drilling Method: Sonic with continuous coring
Sample Type(s): Split Spoon and Core Boring Diameter: 8 in.

Well No. M-111A

Sheet: 1 of 2

Monitoring Well Installed: Yes

Screened Interval: 29.7-39.7 ft.

Weather: Sunny, cool

Logged By: E. Krish

Date/Time Started: 12/5/2007 12:00

Depth of Boring: 40 ft.

Drilling Contractor: Boart Longyear / D. Cervantez

Backfill: NA

Date/Time Finished: 12/10/2007 11:15

Water Level: 34 ft.

| DEPTH (ft) | Sample ID | Sample Depth (ft) | Blows per 6" | Recovery (ft) | Headspace (ppm) | USCS | Graphic Log | MATERIAL IDENTIFICATION, color, description of fine grained material (silt and clay) description of coarse grained material (sand and gravel), structural or mineralogical features, density or stiffness, moisture content, odors or staining. | Well Diagram |
|------------|-----------|-------------------|--------------|---------------|-----------------|------|-------------|--|---|
| 5 | | | | | | SM | | <p>ALLUVIUM: SILTY GRAVELLY SAND, moderate yellowish brown (10YR 5/4), 20% silt, 30% subangular to subrounded fine grained volcanic pea gravel to 1/2" with local calichification, 50% very fine to very coarse grained subangular to subrounded sand (dominant fine to coarse grained).</p> | <p>Steel Guard Pipe 3 Feet Above Ground Surface</p> |
| 10 | | | | | | SM | | <p>GRAVELLY SILTY SAND, moderate yellowish brown (10YR 5/4), 20% silt, 20% angular to subrounded fine grained volcanic pea gravel to 3/8", 60% very fine to very coarse grained (dominant fine to coarse grained) subangular to subrounded moderately calcareous sand.</p> | <p>Top of Riser 2.6 Feet Above Ground Surface</p> |
| 15 | | | | | | SM | | <p>SILTY GRAVELLY SAND, moderate yellowish brown (10YR 5/4), 20% silt, 30% pea gravel (dominant up to 1/2-3/4" with trace 2-3" angular to subangular volcanic clasts), 50% very fine to very coarse grained (dominant fine to medium grained) subangular to subrounded sand. Moderately common calichification.</p> | <p>6" Sch. 40 PVC Riser</p> |
| 20 | | | | | | SM | | <p>-at 13 feet bgs 6" calichified sandy pea gravel.</p> <p>SILTY SAND, moderate yellowish brown (10YR 5/2), 30% silt, 5% 1/10-1/8" fine grained volcanic pea gravel, 70% very fine to very coarse grained (dominant very fine to medium grained) subangular to subrounded sand.</p> | <p>Cement (94%) and Bentonite (6%) Slurry</p> |
| 25 | | | | | | SM | | <p>SILTY GRAVELLY SAND, moderate yellowish brown (10YR 5/2), 20% silt, 30% fine grained pea gravel to 1/2-3/4" angular to subangular volcanic moderately calichified sand gravel clasts, 50% very fine to very coarse grained (dominant fine to medium grained) subangular to subrounded sand.</p> | <p>Bentonite Seal</p> |
| 30 | | | | | | ML | | <p>-local hard calichified zone, pale orange (10YR 8/2), at 19-19.5 feet bgs.</p> <p>-local hard calichified zone, pale orange (10YR 8/2), at 21-21.5 feet bgs.</p> <p>-local hard calichified zone, pale orange (10YR 8/2), at 24-25 feet bgs.</p> <p>-local hard calichified zone, pale orange (10YR 8/2), at 29-29.5 feet bgs.</p> <p>MUDDY CREEK FORMATION: CLAYEY SILT, SILT, AND SANDY SILT, light brown (5YR 6/4), interbedded, common local nodular caliche zones. At 30-34 feet bgs nodules to 3" in clayey silt, moist.</p> | <p>Sand Pack (#2-12)</p> |
| 35 | | | | | | | | <p>-from 34-36 feet bgs 65% silt, 10% clay, 25% very fine grained sand. Groundwater encountered at 34 feet bgs.</p> | <p>Well Screen</p> |

Notes: Muddy Creek Formation begins at 30 feet bgs.

1766.25
1756.25

WELL CONSTRUCTION TRONOX CAPTURE WP.GPJ ENSR CA.GDT 4/25/08

Client: Tronox LLC
 Project Number: 04020-023-160
 Site Description/Location: 500' South of Interceptor Well Field, Henderson, NV
 Coordinates: Not Surveyed Elevation:
 Drilling Method: Sonic with continuous coring
 Sample Type(s): Split Spoon and Core Boring Diameter: 8 In.

Well No. M-111A

Sheet: 2 of 2
 Monitoring Well Installed: Yes
 Screened Interval: 29.7-39.7 ft.

Weather: Sunny, cool Logged By: E. Krish Date/Time Started: 12/5/2007 12:00 Depth of Boring: 40 ft.
 Drilling Contractor: Boart Longyear / D. Cervantez Backfill: NA Date/Time Finished: 12/10/2007 11:15 Water Level: 34 ft.

| DEPTH (ft) | Sample ID | Sample Depth (ft) | Blows per 6" | Recovery (ft) | Headspace (ppm) | USCS | Graphic Log | MATERIAL IDENTIFICATION, color, description of fine grained material (silt and clay) description of coarse grained material (sand and gravel), structural or mineralogical features, density or stiffness, moisture content, odors or staining. | Well Diagram |
|------------|-----------|-------------------|--------------|---------------|-----------------|------|-------------|---|-------------------------------------|
| 40 | | | | | | ML | | <p>MUDDY CREEK FORMATION: CLAYEY SILT, SILT, AND SANDY SILT, light brown (5YR 6/4), interbedded, common local nodular caliche zones. At 30-34 feet bgs nodules to 3" in clayey silt, moist. <i>(continued)</i></p> <p>-from 36-38 feet bgs 80% silt, 10% clay, 10% very fine grained sand.</p> <p>-from 38-40 feet bgs 65% silt, 10% clay, 25% very fine grained sand.</p> | <p>(2" Sch. 40 PVC, 0.01" Slot)</p> |

Total Depth = 40 feet.
 Boring Terminated
 Target depth achieved

Notes: Muddy Creek Formation begins at 30 feet bgs.

Well Log

| | | | |
|--|--|--|----------------------------------|
| Project Number: 2027.02 | | Boring No.: M-150 | |
| Project Name: Vertical Delineation / Capture Zone Eval. | | Logged by: Ed Krish | |
| Drilling Contractor: Boart Longyear | | Date Started: 09/17/09 | Date Completed: 09/17/09 |
| Drilling Method: Rotary Sonic | | Total Depth (ft bgs): 145.0 | Depth to Water (ft bgs): 63.0 |
| Borehole Dia. (in): 6.0 | Completion: Monument | Surface Elevation (ft MSL): | Top of Casing (ft MSL): 1759.107 |
| Blank Casing: SCH 40 PVC | Slotted Casing: Factory slotted SCH 40 PVC, 0.020" Slots | Filter Pack Type: Silica Sand Size: #10-20 | |
| Casing Dia. (in): 2 From (ft bgs): 0 To: 125 | Casing Dia. (in): 2 From (ft bgs): 125 To: 145 | Interval (ft bgs) From: 121 To: 145 | |
| Remarks: Boring advanced with 6.0" casing to 145.0'; Neat Cement from 0' to 117'; 3/8" Holeplug from 117' to 121'. | | | |

| Depth (ft) | Sample I.D. Sample Time | Sample Type | Graphic Log | USCS Code | Formation Name | Material Description | Water Level | 10.6 ev PID (ppm) | 11.7 ev PID (ppm) | Well Construction |
|------------|-------------------------|-------------|-------------|-----------|----------------|---|-------------|-------------------|-------------------|-------------------|
| 1 | | | | SW-SM | QAI | SAND, gravelly, silty; Light brown (5YR 6/4), 60% fine to coarse with minor very coarse, sub-rounded to sub-angular, sand; 20% silt; 20% volcanic pea gravel to 3/4" with locally common cobbles to 4". | | | | |
| 2 | | | | | | | | | | |
| 3 | | | | | | | | | | |
| 4 | | | | | | | | | | |
| 5 | | | | | | | | | | |
| 6 | | | | | | | | | | |
| 7 | | | | | | | | | | |
| 8 | | | | | | | | | | |
| 9 | | | | | | | | | | |
| 10 | | | | SW | QAI | SAND, gravelly, pale yellowish brown (10YR 6/2). 70% fine to medium with common coarse to very coarse sub-rounded to sub-angular sand. 30% volcanic pea gravel (1/8" - 3/4") with minor 1" - 2", angular to sub-angular. Trace silt. | | | | |
| 11 | | | | | | | | | | |
| 12 | | | | | | | | | | |
| 13 | | | | | | | | | | |
| 14 | | | | | | | | | | |
| 15 | | | | | | | | | | |
| 16 | | | | SW | QAI | SAND (SW): silty, gravelly, light brown (5YR 5/6), 60% fine to medium with common coarse to very coarse sub-rounded to sub-angular sand. 10% volcanic pea gravel to 1/2". Wet @ 28' | | | | |
| 17 | | | | | | | | | | |
| 18 | | | | | | | | | | |
| 19 | | | | | | | | | | |
| 20 | | | | ML | Tmcf | SILT (ML), and sandy silt interbedded, moderate yellowish orange (10YR 6/4). Predominately silt with minor thin layers of sandy silt with 10% - 20% very fine grained, sub-angular to sub-rounded sand. Minor scattered zones of semi-hard caliche nodules to 1-1/2". | | | | |
| 21 | | | | | | | | | | |
| 22 | | | | | | | | | | |
| 23 | | | | | | | | | | |
| 24 | | | | | | | | | | |
| 25 | | | | | | | | | | |
| 26 | | | | | | | | | | |
| 27 | | | | | | | | | | |
| 28 | | | | | | | | | | |
| 29 | | | | | | | | | | |
| 30 | | | | | | | | | | |
| 31 | | | | | | | | | | |
| 32 | | | | | | | | | | |
| 33 | | | | | | | | | | |
| 34 | | | | | | | | | | |

DRB-ENVIRO WELL LOG TRONOX-1.GPJ 12/1/09

Well Log

Project Number: 2027.02

Boring No.: M-150

Project Name: Vertical Delineation / Capture Zone Eval.

Logged by: Ed Krish

Drilling Contractor: Boart Longyear

Date Started: 09/17/09

Date Completed: 09/17/09

| Depth (ft) | Sample I.D. Sample Time | Sample Type | Graphic Log | USCS Code | Formation Name | Material Description | Water Level | 10.6 ev PID (ppm) | 11.7 ev PID (ppm) | Well Construction |
|------------|----------------------------|-------------|-------------|-----------|----------------|---|-------------|-------------------|-------------------|-------------------|
| 36 | | | | | | SILT (ML), and sandy silt interbedded, moderate yellowish orange (10YR 6/4). Predominately silt with minor thin layers of sandy silt with 10% - 20% very fine grained, sub-angular to sub-rounded sand. Minor scattered zones of semi-hard caliche nodules to 1-1/2". | | | | |
| 37 | | | | | | | | | | |
| 38 | | | | | | | | | | |
| 39 | | | | | | | | | | |
| 40 | | | | | | | | | | |
| 41 | | | | | | | | | | |
| 42 | | | | | | | | | | |
| 43 | | | | | | | | | | |
| 44 | | | | | | | | | | |
| 45 | | | | ML | Tmcf | | | | | |
| 46 | | | | | | | | | | |
| 47 | | | | | | | | | | |
| 48 | | | | | | | | | | |
| 49 | | | | | | | | | | |
| 50 | | | | | | | | | | |
| 51 | | | | | | | | | | |
| 52 | | | | | | | | | | |
| 53 | | | | | | | | | | |
| 54 | | | | | | | | | | |
| 55 | | | | | | SAND and silty sand, interbedded. Pale yellowish brown (10YR 6/2). Thin layers (2" - 3") of clean fine to medium with minor coarse grained sub-rounded to sub-angular, sand with thicker zones (6" - 8") with 50% silt as matrix. | | | | |
| 56 | | | | | | | | | | |
| 57 | | | | SW-SM | Tmcc | | | | | |
| 58 | | | | | | SILT (ML), sandy with minor SILT interbedded. Light brown (5YR 6/4), predominantly sandy silt with 10% - 20% very fine grained, sub-angular to sub-rounded sand. Scattered thin caliche zones of soft thin layers and hard nodules. | | | | |
| 59 | | | | | | | | | | |
| 60 | | | | | | | | | | |
| 61 | | | | | | | | | | |
| 62 | | | | | | | | | | |
| 63 | | | | | | | | | | |
| 64 | | | | | | | | | | |
| 65 | | | | | | | | | | |
| 66 | | | | | | | | | | |
| 67 | | | | | | | | | | |
| 68 | | | | ML | Tmcf | | | | | |
| 69 | | | | | | | | | | |
| 70 | | | | | | | | | | |
| 71 | | | | | | | | | | |
| 72 | | | | | | | | | | |
| 73 | | | | | | | | | | |
| 74 | | | | | | | | | | |

DRB-ENVIRO WELL LOG TRONOX-1.GPJ 12/1/09

Well Log

| | |
|---|--------------------------|
| Project Number: 2027.02 | Boring No.: M-150 |
| Project Name: Vertical Delineation / Capture Zone Eval. | Logged by: Ed Krish |
| Drilling Contractor: Boart Longyear | Date Started: 09/17/09 |
| | Date Completed: 09/17/09 |

| Depth (ft) | Sample I.D. Sample Time | Sample Type | Graphic Log | USCS Code | Formation Name | Material Description | Water Level | 10.6 ev PID (ppm) | 11.7 ev PID (ppm) | Well Construction |
|------------|----------------------------|-------------|-------------|-----------|----------------|---|-------------|-------------------|-------------------|-------------------|
| 76 | | | | | | SILT (ML), sandy with minor SILT interbedded. Light brown (5YR 6/4), predominantly sandy silt with 10% - 20% very fine grained, sub-angular to sub-rounded sand. Scattered thin caliche zones of soft thin layers and hard nodules. | | | | |
| 77 | | | | | | | | | | |
| 78 | | | | | | | | | | |
| 79 | | | | | | 77' - 77.5' sandy pea gravel up to 3/8" diameter, 30% - 40% fine to coarse, sub-rounded to sub-angular volcanic granules. | | | | |
| 80 | | | | | | 80' - 95' common caliche nodules. | | | | |
| 81 | | | | | | | | | | |
| 82 | | | | | | | | | | |
| 83 | | | | | | | | | | |
| 84 | | | | | | | | | | |
| 85 | | | | | | | | | | |
| 86 | | | | | | | | | | |
| 87 | | | | | | | | | | |
| 88 | | | | | | | | | | |
| 89 | | | | | | | | | | |
| 90 | | | | | | 80' - 95' common caliche nodules. | | | | |
| 91 | | | | | | | | | | |
| 92 | | | | | | | | | | |
| 93 | | | | | | | | | | |
| 94 | | | | | | | | | | |
| 95 | | | | ML | Tmcf | | | | | |
| 96 | | | | | | | | | | |
| 97 | | | | | | | | | | |
| 98 | | | | | | | | | | |
| 99 | | | | | | | | | | |
| 100 | | | | | | | | | | |
| 101 | | | | | | | | | | |
| 102 | | | | | | | | | | |
| 103 | | | | | | | | | | |
| 104 | | | | | | | | | | |
| 105 | | | | | | | | | | |
| 106 | | | | | | | | | | |
| 107 | | | | | | | | | | |
| 108 | | | | | | 108' - 110' common caliche nodules. | | | | |
| 109 | | | | | | | | | | |
| 110 | | | | | | | | | | |
| 111 | | | | | | | | | | |
| 112 | | | | | | | | | | |
| 113 | | | | | | | | | | |
| 114 | | | | | | 114' - 116' common caliche nodules. | | | | |

DRB-ENVIRO WELL LOG TRONOX-1.GPJ 12/1/09

Well Log

Project Number: 2027.02

Boring No.: M-150

Project Name: Vertical Delineation / Capture Zone Eval.

Logged by: Ed Krish

Drilling Contractor: Boart Longyear

Date Started: 09/17/09

Date Completed: 09/17/09

| Depth (ft) | Sample I.D. Sample Time | Sample Type | Graphic Log | USCS Code | Formation Name | Material Description | Water Level | 10.6 ev PID (ppm) | 11.7 ev PID (ppm) | Well Construction | |
|------------|----------------------------|-------------|-------------|-----------|----------------|---|-------------|-------------------|-------------------|-------------------|--|
| 116 | | | | ML | Tmcf | SILT (ML), sandy with minor SILT interbedded. Light brown (5YR 6/4), predominantly sandy silt with 10% - 20% very fine grained, sub-angular to sub-rounded sand. Scattered thin caliche zones of soft thin layers and hard nodules. | | | | | |
| 117 | | | | | | | | | | | |
| 118 | | | | | | | | | | | |
| 119 | | | | | | | | | | | |
| 120 | | | | | | | | | | | |
| 121 | | | | | | Clay, with minor amounts of silt. White (N9) to 124' then mottled white (N9) and yellow gray (5Y 8/1). Abundant soft caliche to 124', then minor scattered soft caliche to 133'. | | | | | |
| 122 | | | | | | | | | | | |
| 123 | | | | | | | | | | | |
| 124 | | | | | | | | | | | |
| 125 | | | | | | | | | | | |
| 126 | | | | CL | Tmcf | | | | | | |
| 127 | | | | | | | | | | | |
| 128 | | | | | | | | | | | |
| 129 | | | | | | | | | | | |
| 130 | | | | | | | | | | | |
| 131 | | | | | | | | | | | |
| 132 | | | | | | | | | | | |
| 133 | | | | | | | | | | | |
| 134 | | | | | | SILT (ML), sandy, greyish orange (10YR 7/4). 10% - 15% very fine grained, sub-angular to sub-rounded sand in silt matrix. Scattered soft caliche layers and semi-hard nodules to 1". | | | | | |
| 135 | | | | | | | | | | | |
| 136 | | | | | | | | | | | |
| 137 | | | | | | | | | | | |
| 138 | | | | ML | Tmcc | | | | | | |
| 139 | | | | | | | | | | | |
| 140 | | | | | | | | | | | |
| 141 | | | | | | | | | | | |
| 142 | | | | | | | | | | | |
| 143 | | | | | | | | | | | |
| 144 | | | | ML | Tmcf | SILT (ML), moderate greyish orange (10YR 6/4) with 0% - 10% very fine grained sand in matrix. | | | | | |
| 145 | | | | | | | | | | | |
| 146 | | | | | | TD = 145' on 9-17-09 | | | | | |
| 147 | | | | | | | | | | | |
| 148 | | | | | | | | | | | |
| 149 | | | | | | | | | | | |
| 150 | | | | | | | | | | | |
| 151 | | | | | | | | | | | |
| 152 | | | | | | | | | | | |
| 153 | | | | | | | | | | | |
| 154 | | | | | | | | | | | |

DRB-ENVIRO WELL LOG TRONOX-1.GPJ 12/1/09

Well Log

| | | | |
|--|--|---|----------------------------------|
| Project Number: 2027.02 | | Boring No.: M-154 | |
| Project Name: Vertical Delineation / Capture Zone Eval. | | Logged by: Ed Krish | |
| Drilling Contractor: Boart Longyear | | Date Started: 09/30/09 | Date Completed: 10/01/09 |
| Drilling Method: Rotary Sonic | | Total Depth (ft bgs): 195.0 | Depth to Water (ft bgs): |
| Borehole Dia. (in): 6.0 | Completion: Monument | Surface Elevation (ft MSL): | Top of Casing (ft MSL): 1758.893 |
| Blank Casing: SCH 40 PVC Casing Dia. (in): 2 From (ft bgs): 0 To: 175 | Slotted Casing: Factory slotted SCH 40 PVC, 0.020" Slots Casing Dia. (in): 2 From (ft bgs): 175 To: 195 | Filter Pack Type: Silica Sand Size: #10-20 Interval (ft bgs) From: 171 To: 195 | |
| Remarks: Boring located 15' west of M-150; Neat Cement from 0' to 167'; 3/8" Holeplug from 167' to 171'. | | | |

| Depth (ft) | Sample I.D. Sample Time | Sample Type | Graphic Log | USCS Code | Formation Name | Material Description | Water Level | 10.6 ev PID (ppm) | 11.7 ev PID (ppm) | Well Construction |
|------------|----------------------------|-------------|-------------|-----------|----------------|----------------------|-------------|-------------------|-------------------|-------------------|
| 1 | | | | | | | | | | |
| 2 | | | | | | | | | | |
| 3 | | | | | | | | | | |
| 4 | | | | | | | | | | |
| 5 | | | | | | | | | | |
| 6 | | | | | | | | | | |
| 7 | | | | | | | | | | |
| 8 | | | | | | | | | | |
| 9 | | | | | | | | | | |
| 10 | | | | | | | | | | |
| 11 | | | | | | | | | | |
| 12 | | | | | | | | | | |
| 13 | | | | | | | | | | |
| 14 | | | | | | | | | | |
| 15 | | | | | | | | | | |
| 16 | | | | | | | | | | |
| 17 | | | | | | | | | | |
| 18 | | | | | | | | | | |
| 19 | | | | | | | | | | |
| 20 | | | | | | | | | | |
| 21 | | | | | | | | | | |
| 22 | | | | | | | | | | |
| 23 | | | | | | | | | | |
| 24 | | | | | | | | | | |
| 25 | | | | | | | | | | |
| 26 | | | | | | | | | | |
| 27 | | | | | | | | | | |
| 28 | | | | | | | | | | |
| 29 | | | | | | | | | | |
| 30 | | | | | | | | | | |
| 31 | | | | | | | | | | |
| 32 | | | | | | | | | | |
| 33 | | | | | | | | | | |
| 34 | | | | | | | | | | |

DRB-ENVIRO WELL LOG TRONOX-1.GPJ 12/1/09

Well Log

Project Number: 2027.02

Boring No.: M-154

Project Name: Vertical Delineation / Capture Zone Eval.

Logged by: Ed Krish

Drilling Contractor: Boart Longyear

Date Started: 09/30/09

Date Completed: 10/01/09

| Depth (ft) | Sample I.D. Sample Time | Sample Type | Graphic Log | USCS Code | Formation Name | Material Description | Water Level | 10.6 ev PID (ppm) | 11.7 ev PID (ppm) | Well Construction |
|------------|----------------------------|-------------|-------------|-----------|----------------|----------------------|-------------|-------------------|-------------------|-------------------|
| 36 | | | | | | | | | | |
| 37 | | | | | | | | | | |
| 38 | | | | | | | | | | |
| 39 | | | | | | | | | | |
| 40 | | | | | | | | | | |
| 41 | | | | | | | | | | |
| 42 | | | | | | | | | | |
| 43 | | | | | | | | | | |
| 44 | | | | | | | | | | |
| 45 | | | | | | | | | | |
| 46 | | | | | | | | | | |
| 47 | | | | | | | | | | |
| 48 | | | | | | | | | | |
| 49 | | | | | | | | | | |
| 50 | | | | | | | | | | |
| 51 | | | | | | | | | | |
| 52 | | | | | | | | | | |
| 53 | | | | | | | | | | |
| 54 | | | | | | | | | | |
| 55 | | | | | | | | | | |
| 56 | | | | | | | | | | |
| 57 | | | | | | | | | | |
| 58 | | | | | | | | | | |
| 59 | | | | | | | | | | |
| 60 | | | | | | | | | | |
| 61 | | | | | | | | | | |
| 62 | | | | | | | | | | |
| 63 | | | | | | | | | | |
| 64 | | | | | | | | | | |
| 65 | | | | | | | | | | |
| 66 | | | | | | | | | | |
| 67 | | | | | | | | | | |
| 68 | | | | | | | | | | |
| 69 | | | | | | | | | | |
| 70 | | | | | | | | | | |
| 71 | | | | | | | | | | |
| 72 | | | | | | | | | | |
| 73 | | | | | | | | | | |
| 74 | | | | | | | | | | |

DRB-ENVIRO WELL LOG TRONOX-1.GPJ 12/1/09

Well Log

Project Number: 2027.02

Boring No.: M-154

Project Name: Vertical Delineation / Capture Zone Eval.

Logged by: Ed Krish

Drilling Contractor: Boart Longyear

Date Started: 09/30/09

Date Completed: 10/01/09

| Depth (ft) | Sample I.D. Sample Time | Sample Type | Graphic Log | USCS Code | Formation Name | Material Description | Water Level | 10.6 ev PID (ppm) | 11.7 ev PID (ppm) | Well Construction |
|------------|----------------------------|-------------|-------------|-----------|----------------|----------------------|-------------|-------------------|-------------------|-------------------|
| 76 | | | | | | | | | | |
| 77 | | | | | | | | | | |
| 78 | | | | | | | | | | |
| 79 | | | | | | | | | | |
| 80 | | | | | | | | | | |
| 81 | | | | | | | | | | |
| 82 | | | | | | | | | | |
| 83 | | | | | | | | | | |
| 84 | | | | | | | | | | |
| 85 | | | | | | | | | | |
| 86 | | | | | | | | | | |
| 87 | | | | | | | | | | |
| 88 | | | | | | | | | | |
| 89 | | | | | | | | | | |
| 90 | | | | | | | | | | |
| 91 | | | | | | | | | | |
| 92 | | | | | | | | | | |
| 93 | | | | | | | | | | |
| 94 | | | | | | | | | | |
| 95 | | | | | | | | | | |
| 96 | | | | | | | | | | |
| 97 | | | | | | | | | | |
| 98 | | | | | | | | | | |
| 99 | | | | | | | | | | |
| 100 | | | | | | | | | | |
| 101 | | | | | | | | | | |
| 102 | | | | | | | | | | |
| 103 | | | | | | | | | | |
| 104 | | | | | | | | | | |
| 105 | | | | | | | | | | |
| 106 | | | | | | | | | | |
| 107 | | | | | | | | | | |
| 108 | | | | | | | | | | |
| 109 | | | | | | | | | | |
| 110 | | | | | | | | | | |
| 111 | | | | | | | | | | |
| 112 | | | | | | | | | | |
| 113 | | | | | | | | | | |
| 114 | | | | | | | | | | |

DRB-ENVIRO WELL LOG TRONOX-1.GPJ 12/1/09

Well Log

| | |
|---|--------------------------|
| Project Number: 2027.02 | Boring No.: M-154 |
| Project Name: Vertical Delineation / Capture Zone Eval. | Logged by: Ed Krish |
| Drilling Contractor: Boart Longyear | Date Started: 09/30/09 |
| | Date Completed: 10/01/09 |

| Depth (ft) | Sample I.D. Sample Time | Sample Type | Graphic Log | USCS Code | Formation Name | Material Description | Water Level | 10.6 ev PID (ppm) | 11.7 ev PID (ppm) | Well Construction |
|------------|----------------------------|-------------|-------------|-----------|----------------|--|-------------|-------------------|-------------------|-------------------|
| 116 | | | | | | | | | | |
| 117 | | | | | | | | | | |
| 118 | | | | | | | | | | |
| 119 | | | | | | | | | | |
| 120 | | | | | | | | | | |
| 121 | | | | | | | | | | |
| 122 | | | | | | | | | | |
| 123 | | | | | | | | | | |
| 124 | | | | | | | | | | |
| 125 | | | | | | | | | | |
| 126 | | | | | | | | | | |
| 127 | | | | | | | | | | |
| 128 | | | | | | | | | | |
| 129 | | | | | | | | | | |
| 130 | | | | | | | | | | |
| 131 | | | | | | | | | | |
| 132 | | | | | | | | | | |
| 133 | | | | | | (133' - 143' continued from M-150) | | | | |
| 134 | | | | | | SILT, sandy. | | | | |
| 135 | | | | | | | | | | |
| 136 | | | | | | | | | | |
| 137 | | | | | | | | | | |
| 138 | | | | ML | Tmcf | | | | | |
| 139 | | | | | | | | | | |
| 140 | | | | | | | | | | |
| 141 | | | | | | | | | | |
| 142 | | | | | | | | | | |
| 143 | | | | | | | | | | |
| 144 | | | | | | SILT, medium greyish orange (10YR 6/4) with 0% - 10% | | | | |
| 145 | | | | | | very fine grained sand locally. | | | | |
| 146 | | | | | | | | | | |
| 147 | | | | | | | | | | |
| 148 | | | | | | | | | | |
| 149 | | | | ML | Tmcf | | | | | |
| 150 | | | | | | | | | | |
| 151 | | | | | | | | | | |
| 152 | | | | | | | | | | |
| 153 | | | | | | 153' - 153.5', moderate caliche nodules and stringers. | | | | |
| 154 | | | | | | | | | | |

DRB-ENVIRO.WELL LOG TRONOX-1.GPJ 12/1/09

Well Log

Project Number: 2027.02

Boring No.: M-154

Project Name: Vertical Delineation / Capture Zone Eval.

Logged by: Ed Krish

Drilling Contractor: Boart Longyear

Date Started: 09/30/09

Date Completed: 10/01/09

| Depth (ft) | Sample I.D. Sample Time | Sample Type | Graphic Log | USCS Code | Formation Name | Material Description | Water Level | 10.6 ev PID (ppm) | 11.7 ev PID (ppm) | Well Construction |
|------------|----------------------------|-------------|-------------|-----------|----------------|--|-------------|-------------------|-------------------|-------------------|
| 156 | | | | | | SILT, medium greyish orange (10YR 6/4) with 0% - 10% very fine grained sand locally. | | | | |
| 157 | | | | | | 156' - 156.5', moderate caliche nodules to 1". | | | | |
| 158 | | | | | | | | | | |
| 159 | | | | | | | | | | |
| 160 | | | | ML | Tmcf | 159.5' - 160', moderate caliche nodules to 1/2". | | | | |
| 161 | | | | | | | | | | |
| 162 | | | | | | | | | | |
| 163 | | | | | | | | | | |
| 164 | | | | | | | | | | |
| 165 | | | | | | Moderate caliche nodules. | | | | |
| 166 | | | | | | SILT, sandy, medium greyish orange (10YR 6/4) with 20% - 30% disseminated very fine grained sand in matrix. Locally calichified. | | | | |
| 167 | | | | | | 166' - 168', with 10% very coarse grained sand and 1/8" granules floating in matrix. | | | | |
| 168 | | | | | | | | | | |
| 169 | | | | | | | | | | |
| 170 | | | | | | Moderate caliche nodules. | | | | |
| 171 | | | | | | | | | | |
| 172 | | | | | | | | | | |
| 173 | | | | | | | | | | |
| 174 | | | | | | | | | | |
| 175 | | | | ML | Tmcc | | | | | |
| 176 | | | | | | | | | | |
| 177 | | | | | | | | | | |
| 178 | | | | | | | | | | |
| 179 | | | | | | 179' - 179.5', moderate caliche nodules. | | | | |
| 180 | | | | | | | | | | |
| 181 | | | | | | | | | | |
| 182 | | | | | | 182' - 182.5', moderate caliche nodules. | | | | |
| 183 | | | | | | | | | | |
| 184 | | | | | | | | | | |
| 185 | | | | | | SAND, silty, moderate greyish orange (10YR 6/4), 60% very fine grained sand with 40% silt in matrix. Locally calcareous. Hard caliche nodules 184' - 184.5'. | | | | |
| 186 | | | | | | | | | | |
| 187 | | | | | | | | | | |
| 188 | | | | | | | | | | |
| 189 | | | | | | | | | | |
| 190 | | | | SM | Tmcc | 190' - 195', moderate caliche nodules and stringers. | | | | |
| 191 | | | | | | | | | | |
| 192 | | | | | | | | | | |
| 193 | | | | | | | | | | |
| 194 | | | | | | | | | | |

DRB-ENVIRO WELL LOG TRONOX-1.GPJ 12/1/09

Well Log

| | |
|---|--------------------------|
| Project Number: 2027.02 | Boring No.: M-154 |
| Project Name: Vertical Delineation / Capture Zone Eval. | Logged by: Ed Krish |
| Drilling Contractor: Boart Longyear | Date Started: 09/30/09 |
| | Date Completed: 10/01/09 |

| Depth (ft) | Sample I.D. Sample Time | Sample Type | Graphic Log | USCS Code | Formation Name | Material Description | Water Level | 10.6 ev PID (ppm) | 11.7 ev PID (ppm) | Well Construction |
|------------|----------------------------|-------------|-------------|-----------|----------------|----------------------|-------------|-------------------|-------------------|-------------------|
| 196 | | | | | | TD = 195' on 10-1-09 | | | | |
| 197 | | | | | | | | | | |
| 198 | | | | | | | | | | |
| 199 | | | | | | | | | | |
| 200 | | | | | | | | | | |
| 201 | | | | | | | | | | |
| 202 | | | | | | | | | | |
| 203 | | | | | | | | | | |
| 204 | | | | | | | | | | |
| 205 | | | | | | | | | | |
| 206 | | | | | | | | | | |
| 207 | | | | | | | | | | |
| 208 | | | | | | | | | | |
| 209 | | | | | | | | | | |
| 210 | | | | | | | | | | |
| 211 | | | | | | | | | | |
| 212 | | | | | | | | | | |
| 213 | | | | | | | | | | |
| 214 | | | | | | | | | | |
| 215 | | | | | | | | | | |
| 216 | | | | | | | | | | |
| 217 | | | | | | | | | | |
| 218 | | | | | | | | | | |
| 219 | | | | | | | | | | |
| 220 | | | | | | | | | | |
| 221 | | | | | | | | | | |
| 222 | | | | | | | | | | |
| 223 | | | | | | | | | | |
| 224 | | | | | | | | | | |
| 225 | | | | | | | | | | |
| 226 | | | | | | | | | | |
| 227 | | | | | | | | | | |
| 228 | | | | | | | | | | |
| 229 | | | | | | | | | | |
| 230 | | | | | | | | | | |
| 231 | | | | | | | | | | |
| 232 | | | | | | | | | | |
| 233 | | | | | | | | | | |
| 234 | | | | | | | | | | |

DRB-ENVIRO WELL LOG TRONOX-1.GPJ 12/1/09

EXPLORATION LOG RSAM5

PROJECT: TRONOX PHASE B

PROJECT NO.: 20092518V1

EXPLORATION LOCATION: TRONOX AREA 2

EXPLORATION DATE: 7/30/2009

EXPLORATION SIZE (dia.): 3" CORE BARREL

EQUIPMENT: SDC550-24 SONIC CORE RIG

ELEVATION: EXISTING GROUND SURFACE

LOGGED BY: SEARS/GAREY

INITIAL DEPTH TO WATER: NOT ENCOUNTERED

DATE MEASURED: NA

FINAL DEPTH TO WATER: NOT ENCOUNTERED

DATE MEASURED: NA

| ELEVATION/ DEPTH | SOIL & SAMPLE SYMBOLS | USCS | DESCRIPTION | PI | LL | MOISTURE CONTENT (%) | DRY DENSITY (pcf) | % SWELL | WELL CONSTRUCTION |
|---------------------|----------------------------------|---------------------|--|----|----|-------------------------|----------------------|---------|----------------------|
| | <p>8 10 10</p> <p>50</p> | <p>SW</p> <p>SW</p> | <p>Brown (7.5YR 4/4) well graded SAND, 95% fine-coarse grained, subangular to subrounded, sand, 5% gravel, loose, dry, non plastic, high K, no odor, strong reaction to HCl. Collect samples RSAm5-0.5B, RSAM5009-0.5B; PID readings: 10.6eV=1.4 ppmV, 11.7eV=0.0 ppmV.</p> <p>Collect RSAM5-10B; PID readings: 10.6eV=13.3 ppmV, 11.7eV=5.7 ppmV.</p> <p>Brown (7.5YR 3/4) well graded SAND. 90% fine-coarse grained, subangular to subrounded sand, 5% subrounded gravel, 55 silt. non-low plasticity, low K, strong reaction to HCl, no odor. trace caliche occurring as thin layers and nodules.</p> | | | | | | |

The descriptions contained within this exploration log apply only at the specific exploration location and at the time the exploration was made. It is not intended to be representative of subsurface conditions at other locations or times.

EXPLORATION LOG RSAM5

| | |
|--|--|
| PROJECT: <u>TRONOX PHASE B</u> | PROJECT NO.: <u>20092518V1</u> |
| EXPLORATION LOCATION: <u>TRONOX AREA 2</u> | EXPLORATION DATE: <u>7/30/2009</u> |
| EXPLORATION SIZE (dia.): <u>3" CORE BARREL</u> | EQUIPMENT: <u>SDC550-24 SONIC CORE RIG</u> |
| ELEVATION: <u>EXISTING GROUND SURFACE</u> | LOGGED BY: <u>SEARS/GAREY</u> |

| | |
|--|--------------------------|
| INITIAL DEPTH TO WATER: <u>NOT ENCOUNTERED</u> | DATE MEASURED: <u>NA</u> |
| FINAL DEPTH TO WATER: <u>NOT ENCOUNTERED</u> | DATE MEASURED: <u>NA</u> |

| ELEVATION/ DEPTH | SOIL & SAMPLE SYMBOLS | USCS | DESCRIPTION | PI | LL | MOISTURE CONTENT (%) | DRY DENSITY (pcf) | % SWELL | WELL CONSTRUCTION |
|---------------------|--------------------------|-------|---|----|----|-------------------------|----------------------|---------|----------------------|
| | | | | | | | | | |
| | | SP-SM | Light brown (7.5YR 6/3) well graded SAND with silt, 80% fine grained sand, 20% silt, low plasticity, low K, reacts to HCl, trace gypsum?, no odor. | | | | | | |
| | | SW | Brown (7.5YR 4/3) well graded SAND, 95% fine-coarse grained, subangular to subrounded sand, 5% fine grained, subrounded gravel, strong cementation, reacts with HCl, no odor. | | | | | | |
| | | | Collect sample RSAM5-28B; PID readings: 10.6eV=0.6 ppmV, 11.7eV=0.0 ppmV. | | | | | | |
| | | SP-SM | ...fine grained SAND with silt, 3" layer. | | | | | | |
| | | SW | END OF BORING AT 29.5 FEET | | | | | | |

The descriptions contained within this exploration log apply only at the specific exploration location and at the time the exploration was made. It is not intended to be representative of subsurface conditions at other locations or times.

| | | |
|--|---|--------------------------------------|
| ENSR AECOM ENSR 1220 Avenida Acaso Camarillo, CA 93012 805-388-3775 www.ensr.aecom.com | <i>Client:</i> Tronox | Boring No. SA-15 |
| | <i>Project Number:</i> 04020-023-401 | |
| | <i>Site Location:</i> Henderson, NV | |
| | <i>Coordinates:</i> 26719002 N 827478 E <i>Elevation:</i> 1768 FT | <i>Sheet:</i> 1 of 2 |
| | <i>Drilling Method:</i> Sonic with continuous coring | <i>Monitoring Well Installed:</i> No |
| <i>Sample Type(s):</i> Split Spoon and Core <i>Boring Diameter:</i> 7 In. | <i>Screened Interval:</i> | |

| | | | |
|--|---------------------------------|--------------------------------------|-------------------------------|
| <i>Weather:</i> Clear, slight breeze, mid 80's | <i>Logged By:</i> E. Krish | <i>Date/Time Started:</i> 11/8/2006 | <i>Depth of Boring:</i> 40 FT |
| <i>Drilling Contractor:</i> Prosonic | <i>Backfill:</i> Tremmied grout | <i>Date/Time Finished:</i> 11/8/2006 | <i>Water Level:</i> 37 FT |

| DEPTH (ft) | Sample ID | Sample Depth (ft) | Blows per 6" | Recovery (ft) | Headspace (ppm) | USCS | Graphic Log | MATERIAL IDENTIFICATION, color, description of fine grained material (silt and clay) description of coarse grained material (sand and gravel), structural or mineralogical features, density or stiffness, moisture content, odors or staining. |
|------------|-----------|-------------------|--------------|---------------|-----------------|------|-------------|---|
| 5 | SA15-0.5 | | | 10 | | SW | | ALLUVIUM: GRAVELLY SAND , moderate brown (5YR 4/4), 10-15% silt, 60-75% fine to coarse grained sand with minor very fine and very coarse grained sand, 15-25% gravel, angular to subangular, medium dense, dry, no odor/stain -from 3-5' pebble/cobble sized gravel, to 2" diameter, common |
| 10 | SA15-10 | | | 10 | | | | -from 10-13' caliche, calcareous coatings common |
| 15 | | | | | | | | |
| 20 | SA15-20 | | | 10 | | | | -from 22-24' grayish orange caliche, soft, calcareous coatings common |
| 25 | | | | | | | | |
| 30 | SA15-30 | | | 10 | | | | -from 28-32' grayish orange caliche, semi-hard, calcareous coatings common |
| 35 | | | | | | ML | | MUDDY CREEK FORMATION: SILT , light brown, 0-5% clay, 85-100% silt, 0-10% sand, subrounded, moist, no odor/stain, silt and sandy silt interbedded |

Notes:

BORING LOG 04020023401-LOGS.GPJ ENSR CA.GDT 1/29/07

Client: Tronox
Project Number: 04020-023-401
Site Location: Henderson, NV
Coordinates: 26719002 N 827478 E Elevation: 1768 FT
Drilling Method: Sonic with continuous coring
Sample Type(s): Split Spoon and Core Boring Diameter: 7 In.

Boring No. SA-15

Sheet: 2 of 2
Monitoring Well Installed: No
Screened Interval:

Weather: Clear, slight breeze, mid 80's Logged By: E. Krish Date/Time Started: 11/8/2006 Depth of Boring: 40 FT
Drilling Contractor: Prosonic Backfill: Tremmied grout Date/Time Finished: 11/8/2006 Water Level: 37 FT

| DEPTH (ft) | Sample ID | Sample Depth (ft) | Blows per 6" | Recovery (ft) | Headspace (ppm) | USCS | Graphic Log | |
|------------|-----------|-------------------|--------------|---------------|-----------------|------|--|--|
| | | | | | | ML | <p>MATERIAL IDENTIFICATION, color, description of fine grained material (silt and clay) description of coarse grained material (sand and gravel), structural or mineralogical features, density or stiffness, moisture content, odors or staining.</p> <p>MUDDY CREEK FORMATION: SILT, light brown, 0-5% clay, 85-100% silt, 0-10% sand, subrounded, moist, no odor/stain, silt and sandy silt interbedded (continued)</p> <p>-wet at 37'</p> | |
| | | | | | | | | |
| | | | | | | | | |
| | | | | | | | | |
| 40 | | | | 10 | | | | |

Total Depth = 40 feet.
Boring Terminated
Target depth achieved

Notes:

Boring Log

| | | | |
|---|--|-----------------------------|-------------------------------|
| Project Number: 2027.01 | | Boring No.: SA65 | |
| Project Name: Tronox Phase B Investigation | | Logged by: Dana R. Brown | |
| Drilling Contractor: Boart Longyear Company | | Date Started: 08/25/09 | Date Completed: 08/25/09 |
| Drilling Method: Sonic | | Total Depth (ft bgs): 35.0 | Depth to Water (ft bgs): 31.0 |
| Borehole Dia. (in): 6.0 | | Surface Elevation (ft MSL): | |

Remarks: Abandoned with neat cement grout containing 3% (v/v) bentonite powder from 0.0' to 35.0'.

| Depth (ft) | Sample I.D. Sample Time | Sample Type | Graphic Log | USCS Code | Material Description | 10.6 ev PID (ppm) | 11.7 ev PID (ppm) | Backfill |
|------------|----------------------------|-------------|-------------|-----------|--|-------------------|-------------------|----------|
| 1 | SA65-10B 11:27 | SM | | SM | Silty Sand (SM): Pale yellowish brown 10 YR (6/2), loose to very loose, dry. 5% fine sub-angular gravel to 3/8"+, 70% fine to medium sub-angular sand, 25% non-plastic fines. No odor or staining. | 0.2 | 1.4 | |
| 2 | | | | | | | | |
| 3 | | | | | | | | |
| 4 | | | | | | | | |
| 5 | | | | | | | | |
| 6 | | | | | | | | |
| 7 | | | | | | | | |
| 8 | | | | | | | | |
| 9 | | | | | | | | |
| 10 | | | | | | | | |
| 11 | SA65-20B 11:45 | SP | | SP | Poorly Graded Sand (SP) to Poorly Graded Sand with Silt (SP-SM): Very pale orange 10 YR (8/2), loose to very loose, dry. 2% - 5% fine sub-angular gravel to 1/2", 75% fine sand, 20% (to 10% locally) non-plastic fines. No odor or staining. Gravelly lenses 10.5' - 11.8'; and 14.5' to 15.5' | 0.0 | 1.1 | |
| 12 | | | | | | | | |
| 13 | | | | | | | | |
| 14 | | | | | | | | |
| 15 | | | | | | | | |
| 16 | | | | | | | | |
| 17 | | | | | | | | |
| 18 | | | | | | | | |
| 19 | | | | | | | | |
| 20 | | | | | | | | |
| 21 | SA65-32.5B 12:15 | SP-SM | | SP-SM | Poorly Graded Sand with Silt (SP-SM): Pale yellowish brown 10 YR (6/2), loose, dry to damp. Trace fine sub-angular gravel to 1/2", 80% fine to medium sand, 20% non-plastic fines. Some caliche as veinlets and grain coatings from 25' - 29'. | 0.0 | 0.6 | |
| 22 | | | | | | | | |
| 23 | | | | | | | | |
| 24 | | | | | | | | |
| 25 | | | | | | | | |
| 26 | | | | | | | | |
| 27 | | | | | | | | |
| 28 | | | | | | | | |
| 29 | | | | | | | | |
| 30 | | | | | | | | |
| 31 | SA65-32.5B 12:15 | SM | | SM | Silty Sand (SM): Dark yellowish brown 10 YR (4/2), very loose, wet. Trace fine sub-angular gravel to 3/8"+, 75% medium sub-angular sand, 25% non-plastic fines. Vague organic odor, no staining. | 0.0 | 14.4 | |
| 32 | | | | | | | | |
| 33 | | | | | | | | |
| 34 | | | | | | | | |
| 35 | | | | ML | Silt with Sand (ML): Light brown 5 YR (5/6), medium dense to dense, wet. Trace fine sub-rounded gravel to 3/8"+, 20% - 35% fine sand, 80% - 65% non to moderate-plastic fines. Vague organic odor, no staining. Some caliche as veinlets and grain coatings. | 23.0 | 0.7 | |

DRB-ENVIRO BORING 2027.01.GPJ 2/9/11

Boring Log

Project Number: 2027.01

Boring No.: SA65

Project Name: Tronox Phase B Investigation

Logged by: Dana R. Brown

Drilling Contractor: Boart Longyear Company

Date Started: 08/25/09

Date Completed: 08/25/09

| Depth (ft) | Sample I.D. Sample Time | Sample Type | Graphic Log | USCS Code | Material Description | 10.6 ev PID (ppm) | 11.7 ev PID (ppm) | Backfill |
|------------|----------------------------|-------------|-------------|-----------|------------------------------------|-------------------|-------------------|----------|
| 36 | | | | | Total depth 35.0' @ 12:20, 8-25-09 | | | |
| 37 | | | | | | | | |
| 38 | | | | | | | | |
| 39 | | | | | | | | |
| 40 | | | | | | | | |
| 41 | | | | | | | | |
| 42 | | | | | | | | |
| 43 | | | | | | | | |
| 44 | | | | | | | | |
| 45 | | | | | | | | |
| 46 | | | | | | | | |
| 47 | | | | | | | | |
| 48 | | | | | | | | |
| 49 | | | | | | | | |
| 50 | | | | | | | | |
| 51 | | | | | | | | |
| 52 | | | | | | | | |
| 53 | | | | | | | | |
| 54 | | | | | | | | |
| 55 | | | | | | | | |
| 56 | | | | | | | | |
| 57 | | | | | | | | |
| 58 | | | | | | | | |
| 59 | | | | | | | | |
| 60 | | | | | | | | |
| 61 | | | | | | | | |
| 62 | | | | | | | | |
| 63 | | | | | | | | |
| 64 | | | | | | | | |
| 65 | | | | | | | | |
| 66 | | | | | | | | |
| 67 | | | | | | | | |
| 68 | | | | | | | | |
| 69 | | | | | | | | |
| 70 | | | | | | | | |
| 71 | | | | | | | | |
| 72 | | | | | | | | |
| 73 | | | | | | | | |
| 74 | | | | | | | | |

DRB-ENVIRO BORING: 2027.01.GPJ 2/9/11

Boring Log

| | | | |
|--|-----------------------------|-------------------------------|--|
| Project Number: 2027.01 | | Boring No.: SA94 | |
| Project Name: Tronox Phase B Investigation | | Logged by: Dana R. Brown | |
| Drilling Contractor: Boart Longyear | Date Started: 08/25/09 | Date Completed: 08/25/09 | |
| Drilling Method: Rotary Sonic | Total Depth (ft bgs): 31.5 | Depth to Water (ft bgs): 30.0 | |
| Borehole Dia. (in): 6.0 | Surface Elevation (ft MSL): | | |

Remarks: Abandoned with neat cement grout containing 3% (v/v) bentonite powder from 0.0' to 31.5'.

| Depth (ft) | Sample I.D. Sample Time | Sample Type | Graphic Log | USCS Code | Formation Name | Material Description | Water Level | 10.6 ev PID (ppm) | 11.7 ev PID (ppm) | Backfill |
|------------|----------------------------|-------------|-------------|-----------|----------------|--|-------------|-------------------|-------------------|----------|
| 1 | SA94-0.5B 08:09 | | | SM | Qal | Silty Sand (SM): Pale yellowish brown 10 YR (6/2), very loose, dry. 5% fine sub-angular gravel to 1"+, 70% fine to medium sub-angular sand, 25% non-plastic fines. Vague organic odor, no staining. | | | | |
| 2 | | | | | | | | | | |
| 3 | | | | | | | | | | |
| 4 | SA94-10B 08:34 | | | SP | Qal | Poorly Graded Sand (SP): Very pale orange 10 YR (8/2), very loose, dry. 5% fine sub-angular gravel to 1/2", 89% fine to medium sand, 6% non-plastic fines. No odor or staining. | 4.6 | 0.2 | | |
| 5 | | | | | | Gravelly lenses 7.0' - 8.0'; and 12.5' to 13.5' | 1.7 | 0.0 | | |
| 6 | | | | | | | 1.8 | 0.0 | | |
| 7 | | | | | | | 1.8 | 0.0 | | |
| 8 | | | | | | | 7.0 | 0.0 | | |
| 9 | | | | | | | 4.5 | 0.0 | | |
| 10 | | | | | | 4.2 | 0.0 | | | |
| 11 | 5.5 | 0.0 | | | | | | | | |
| 12 | SA94-29B 08:50 | | | SM | Qal | Silty Sand (SM): Pale yellowish brown 10 YR (6/2), loose, dry. 2% fine sub-angular gravel to 3/8"+, 70% fine - medium sub-angular sand, 28% non to moderate-plastic fines. No odor or staining. Some caliche as veinlets and grain coatings. | 8.4 | 0.0 | | |
| 13 | | | | | | 8.3 | 0.1 | | | |
| 14 | | | | | | 18.0 | 0.5 | | | |
| 15 | | | | | | 18.6 | 0.4 | | | |
| 16 | | | | | | 15.7 | 0.4 | | | |
| 17 | | | | | | | | | | |
| 18 | SA94-32.5B 12:15 | | | | | Total depth 31.5' @ 09:00, 8-25-09 | | | | |
| 19 | | | | | | | | | | |

DRB-ENVIRO BORING 2027.01.GPJ 1/13/10

EXPLORATION LOG SA104-A2

PROJECT: TRONOX PHASE B
EXPLORATION LOCATION: TRONOX AREA 2
EXPLORATION SIZE (dia.): 3" CORE BARREL
ELEVATION: EXISTING GROUND SURFACE

PROJECT NO.: 20092518V1
EXPLORATION DATE: 8-20-2009
EQUIPMENT: SDC550-24 SONIC CORE RIG
LOGGED BY: SEARS/GAREY

INITIAL DEPTH TO WATER: NOT ENCOUNTERED
FINAL DEPTH TO WATER: NOT ENCOUNTERED

DATE MEASURED: N/A
DATE MEASURED: N/A

| ELEVATION/ DEPTH | SOIL & SAMPLE SYMBOLS | USCS | DESCRIPTION | PI | LL | MOISTURE CONTENT (%) | DRY DENSITY (pcf) | Pocket Penetrometer (tsf) | WELL CONSTRUCTION |
|---------------------|--------------------------|------|--|----|----|-------------------------|----------------------|---------------------------------|----------------------|
| | | SW | SAND, dark brown (7.5YR 3/2), 95% fine to coarse sub-angular to sub-rounded sand, 5% volcanic gravel, dense, dry, no plasticity, calichified zones | | | | | | |
| | | SW | ...color to reddish brown (5YR 4/4) | | | | | | |
| | | SW | Collect SA104-10B, SA104009-10B, PID readings: 10.6 eV = 0.4 ppmV, 11.7 eV = 0.6 ppmV SAND, reddish brown (5YR 5/3), 65% fine to medium sand, 30% coarse sand, 5% fine volcanic gravel, dense, dry, low plasticity, strong HCl reaction | | | | | | |
| | | SP | SAND, reddish brown (5YR 5/4), 90% fine to medium sand, 10% coarse sand, trace fine sub-angular gravel, dense, dry, low plasticity, strong HCl reaction | | | | | | |

The descriptions contained within this exploration log apply only at the specific exploration location and at the time the exploration was made. It is not intended to be representative of subsurface conditions at other locations or times.

EXPLORATION LOG SA104-A2

PROJECT: TRONOX PHASE B
 EXPLORATION LOCATION: TRONOX AREA 2
 EXPLORATION SIZE (dia.): 3" CORE BARREL
 ELEVATION: EXISTING GROUND SURFACE

PROJECT NO.: 20092518V1
 EXPLORATION DATE: 8-20-2009
 EQUIPMENT: SDC550-24 SONIC CORE RIG
 LOGGED BY: SEARS/GAREY

INITIAL DEPTH TO WATER: NOT ENCOUNTERED
 FINAL DEPTH TO WATER: NOT ENCOUNTERED

DATE MEASURED: N/A
 DATE MEASURED: N/A

| ELEVATION/ DEPTH | SOIL & SAMPLE SYMBOLS | USCS | DESCRIPTION | PI | LL | MOISTURE CONTENT (%) | DRY DENSITY (pcf) | Pocket Penetrometer (tsf) | WELL CONSTRUCTION |
|---------------------|--------------------------|------|---|----|----|-------------------------|----------------------|---------------------------------|----------------------|
| | | | | | | | | | |
| 20 | | | | | | | | | |
| 22.5 | | SP | ...gravel to 1" diameter | | | | | | |
| 25 | | | | | | | | | |
| 27.5 | | | | | | | | | |
| 30 | | SP | ...moderate calcite cementation with caliche nodules | | | | | | |
| 30 | | SP | Collect SA104-30B, PID readings: 10.6 eV = 0.3 ppmV, 11.7 eV = 0.0 ppmV SAND, reddish brown (5YR 4/3), 85% fine to medium sand, 15% coarse sand, trace fine sub-angular volcanic gravel, dense, dry, low plasticity, moderate cemented zones, small calcite crystals visible, caliche nodules less than 0.5" diameter present, strong HCl reaction | | | | | | |
| 32.5 | | | END OF BORING AT 31.5 FEET | | | | | | |
| 35 | | | | | | | | | |

The descriptions contained within this exploration log apply only at the specific exploration location and at the time the exploration was made. It is not intended to be representative of subsurface conditions at other locations or times.

Boring Log

| | | | |
|---|--|-----------------------------|--------------------------|
| Project Number: 2027.01 | | Boring No.: SA129_2 | |
| Project Name: Tronox Phase B Investigation | | Logged by: Becki Dano | |
| Drilling Contractor: Boart Longyear Company | | Date Started: 04/15/10 | Date Completed: 04/15/10 |
| Drilling Method: Sonic | | Total Depth (ft bgs): 10.0 | Depth to Water (ft bgs): |
| Borehole Dia. (in): 4 | | Surface Elevation (ft MSL): | |

Remarks: Abandoned with neat cement grout containing 3% (v/v) bentonite powder from 0.0' to 10.0'.

| Depth (ft) | Sample I.D. Sample Time | Sample Type | Graphic Log | USCS Code | Material Description | 10.6 ev PID (ppm) | 11.7 ev PID (ppm) | Backfill |
|------------|--|-------------|-------------|-----------|---|-------------------|-------------------|----------|
| 1 | SA129-3 16:31 SA129-4 16:37 SA129-5 13:44 SA129-6 13:51 SA129-7 13:57 SA129-8 17:00 SA129-9 17:05 | | | SM | Silty sand (SM), dark yellowish brown (10YR 3/4), loose, dry. 5% fine gravel to 1", 70% fine to coarse sub-angular sand, 25% non-plastic fines, no odor or staining. | | | |
| 2 | | | | ML | | | | |
| 3 | | | | | Silty sand (SM), reddish brown (5YR 4/3), loose to medium-dense, dry. 5% fine gravel to 1", 75% fine to coarse sub-angular sand, 20% non-plastic fines, no odor or staining. @ 3' - 4' many clasts of indurated sediment, breaks easily by hand. | | 3.6 | |
| 4 | | | | | | | | |
| 5 | | | | SM | | | | |
| 6 | | | | | | | 0.3 | |
| 7 | | | | | | | | |
| 8 | | | | | | | 0.0 | |
| 9 | | | | | | | | |
| 10 | | | | | | | | |
| 11 | | | | | Total depth 10.0'. | | | |
| 12 | | | | | | | | |
| 13 | | | | | | | | |
| 14 | | | | | | | | |
| 15 | | | | | | | | |
| 16 | | | | | | | | |
| 17 | | | | | | | | |
| 18 | | | | | | | | |
| 19 | | | | | | | | |
| 20 | | | | | | | | |
| 21 | | | | | | | | |
| 22 | | | | | | | | |
| 23 | | | | | | | | |
| 24 | | | | | | | | |
| 25 | | | | | | | | |
| 26 | | | | | | | | |
| 27 | | | | | | | | |
| 28 | | | | | | | | |
| 29 | | | | | | | | |
| 30 | | | | | | | | |
| 31 | | | | | | | | |
| 32 | | | | | | | | |
| 33 | | | | | | | | |
| 34 | | | | | | | | |

DRB-ENVIRO BORING 2027.01.GPJ 2/11/11

EXPLORATION LOG SA129-A2

PROJECT: TRONOX PHASE B

PROJECT NO.: 20092518V1

EXPLORATION LOCATION: TRONOX AREA 2

EXPLORATION DATE: 9-21-2009

EXPLORATION SIZE (dia.): 3" CORE BARREL

EQUIPMENT: SDC550-24 SONIC CORE RIG

ELEVATION: EXISTING GROUND SURFACE

LOGGED BY: SEARS/BRINKERHOFF

INITIAL DEPTH TO WATER: NOT ENCOUNTERED

DATE MEASURED: N/A

FINAL DEPTH TO WATER: NOT ENCOUNTERED

DATE MEASURED: N/A

| ELEVATION/ DEPTH | SOIL & SAMPLE SYMBOLS | USCS | DESCRIPTION | PI | LL | MOISTURE CONTENT (%) | DRY DENSITY (pcf) | Pocket Penetrometer (tsf) | WELL CONSTRUCTION |
|---------------------|--------------------------|-------------|--|----|----|-------------------------|----------------------|---------------------------------|----------------------|
| | | SP-SM | Silty SAND, yellowish brown (10YR 5/4), 35% silt, 65% fine to medium sand, trace gravel, loose, dry, strong HCl reaction | | | | | | |
| | | SP-SM | ...4" thick ash layer, grey (10YR 6/1) | | | | | | |
| | | SP-SM | ...weak to moderate cementation, slight chemical odor | | | | | | |
| | | SP-SM | Collect SA129-10B, PID readings: 10.6 eV = 0.3 ppmV, 11.7 eV = 1.3 ppmV | | | | | | |
| | | SP-SM | ...gravel content increases to 10% | | | | | | |
| | | ML SP-SM | SILT with sand, light brown (7.5YR 6/3), 70% silt, 20% fine to medium sand, 10% fine to coarse gravel, dense, dry, strong HCl reaction Silty SAND, yellowish brown (10YR 5/4), 30% silt, 65% fine to medium sand, 5% fine to medium gravel, dense, dry, weak to moderate cementation, strong HCl reaction, slight chemical odor | | | | | | |

The descriptions contained within this exploration log apply only at the specific exploration location and at the time the exploration was made. It is not intended to be representative of subsurface conditions at other locations or times.

EXPLORATION LOG SA129-A2

PROJECT: TRONOX PHASE B
EXPLORATION LOCATION: TRONOX AREA 2
EXPLORATION SIZE (dia.): 3" CORE BARREL
ELEVATION: EXISTING GROUND SURFACE

PROJECT NO.: 20092518V1
EXPLORATION DATE: 9-21-2009
EQUIPMENT: SDC550-24 SONIC CORE RIG
LOGGED BY: SEARS/BRINKERHOFF

INITIAL DEPTH TO WATER: NOT ENCOUNTERED
FINAL DEPTH TO WATER: NOT ENCOUNTERED

DATE MEASURED: N/A
DATE MEASURED: N/A

| ELEVATION/ DEPTH | SOIL & SAMPLE SYMBOLS | USCS | DESCRIPTION | PI | LL | MOISTURE CONTENT (%) | DRY DENSITY (pcf) | Pocket Penetrometer (tsf) | WELL CONSTRUCTION |
|---------------------|--------------------------|-------|---|----|----|-------------------------|----------------------|---------------------------------|----------------------|
| | | | | | | | | | |
| | | SP-SM | ...color to brown (7.5YR 4/4) | | | | | | |
| | | SP-SM | Collect SA129-29B, PID readings: 10.6 eV = 0.3 ppmV, 11.7 eV = 0.0 ppmV | | | | | | |
| | | | END OF BORING AT 30.5 FEET | | | | | | |
| | | | | | | | | | |

The descriptions contained within this exploration log apply only at the specific exploration location and at the time the exploration was made. It is not intended to be representative of subsurface conditions at other locations or times.

EXPLORATION LOG SA198-A2

PROJECT: TRONOX PHASE B
 EXPLORATION LOCATION: TRONOX AREA 2
 EXPLORATION SIZE (dia.): 3" CORE BARREL
 ELEVATION: EXISTING GROUND SURFACE

PROJECT NO.: 20092518V1
 EXPLORATION DATE: 8-20-2009
 EQUIPMENT: SDC550-24 SONIC CORE RIG
 LOGGED BY: SEARS/GAREY

INITIAL DEPTH TO WATER: NOT ENCOUNTERED
 FINAL DEPTH TO WATER: NOT ENCOUNTERED

DATE MEASURED: N/A
 DATE MEASURED: N/A

| ELEVATION/ DEPTH | SOIL & SAMPLE SYMBOLS | USCS | DESCRIPTION | PI | LL | MOISTURE CONTENT (%) | DRY DENSITY (pcf) | Pocket Penetrometer (tsf) | WELL CONSTRUCTION |
|---------------------|--------------------------|------|--|----|----|-------------------------|----------------------|---------------------------------|----------------------|
| | | SW | SAND, reddish brown (5YR 4/4), 95% fine to coarse sub-angular to sub-rounded sand, 5% fine to medium gravel, loose to dense, dry, weak to moderately cemented caliche zones, strong HCl reaction | | | | | | |
| | | SW | ...gravel content to 10% | | | | | | |
| | | SW | Collect SA198-10B, PID readings: 10.6 eV = 0.4 ppmV, 11.7 eV = 0.0 ppmV | | | | | | |
| | | SW | ...gravel content to 15% | | | | | | |

The descriptions contained within this exploration log apply only at the specific exploration location and at the time the exploration was made. It is not intended to be representative of subsurface conditions at other locations or times.

EXPLORATION LOG SA198-A2

PROJECT: TRONOX PHASE B
 EXPLORATION LOCATION: TRONOX AREA 2
 EXPLORATION SIZE (dia.): 3" CORE BARREL
 ELEVATION: EXISTING GROUND SURFACE

PROJECT NO.: 20092518V1
 EXPLORATION DATE: 8-20-2009
 EQUIPMENT: SDC550-24 SONIC CORE RIG
 LOGGED BY: SEARS/GAREY

INITIAL DEPTH TO WATER: NOT ENCOUNTERED
 FINAL DEPTH TO WATER: NOT ENCOUNTERED

DATE MEASURED: N/A
 DATE MEASURED: N/A



| ELEVATION/ DEPTH | SOIL & SAMPLE SYMBOLS | USCS | DESCRIPTION | PI | LL | MOISTURE CONTENT (%) | DRY DENSITY (pcf) | Pocket Penetrometer (tsf) | WELL CONSTRUCTION |
|---------------------|--------------------------|------|---|----|----|-------------------------|----------------------|---------------------------------|----------------------|
| 20 | | | | | | | | | |
| 22.5 | | SW | ...strong cementation (calcite cement) | | | | | | |
| 25 | | SM | Silty SAND, yellowish brown (10YR 5/6), 15% silt, 85% very fine to fine sand, loose, moist, low to medium plasticity, weak HCl reaction | | | | | | |
| 27.5 | | SM | Collect SA198-27B, PID readings: 10.6 eV = 2.1 ppmV, 11.7 eV = 0.3 ppmV | | | | | | |
| 30 | | | END OF BORING AT 28.5 FEET | | | | | | |
| 32.5 | | | | | | | | | |
| 35 | | | | | | | | | |

The descriptions contained within this exploration log apply only at the specific exploration location and at the time the exploration was made. It is not intended to be representative of subsurface conditions at other locations or times.

Boring Log

| | | | |
|---|--|-----------------------------|--------------------------|
| Project Number: 2027.01 | | Boring No.: SSAM5-03 | |
| Project Name: Tronox Phase B Investigation | | Logged by: Eric Taub | |
| Drilling Contractor: Boart Longyear Company | | Date Started: 05/04/10 | Date Completed: 05/04/10 |
| Drilling Method: Sonic | | Total Depth (ft bgs): 11.0 | Depth to Water (ft bgs): |
| Borehole Dia. (in): 6 | | Surface Elevation (ft MSL): | |

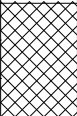
Remarks: Abandoned with neat cement grout containing 3% (v/v) bentonite powder from 0.0' to 11.0'.

| Depth (ft) | Sample I.D. Sample Time | Sample Type | Graphic Log | USCS Code | Material Description | 10.6 ev PID (ppm) | 11.7 ev PID (ppm) | Backfill |
|------------|--------------------------------------|-------------|--|-----------|--|-------------------|-------------------|--------------------|
| 1 | SSAM5-03-1, SSAM5-03-1FD 14:40 | |  | Fill | Fill: poorly graded sand (SP), yellowish brown (10YR 5/4), loose to very loose, slightly moist. 5% fine sub-rounded gravel to 1/2", 90% fine to medium sub-angular sand, 5% nonplastic fines. Heavy staining and odor. | | | |
| 2 | SSAM5-03-2 14:50 | |  | SP | Poorly graded sand (SP): yellowish brown (10YR 5/4), loose to very loose, slightly moist. 5% fine sub-rounded gravel to 1/2", 90% fine to medium sub-angular sand, 5% nonplastic fines, no odor. Light staining. | 3.0 | 2.2 | |
| 3 | SSAM5-03-3 14:58 | | | | | | | |
| 4 | SSAM5-03-4 15:03 | | | | | | | |
| 5 | SSAM5-03-5 15:07 | | | | | | | |
| 6 | SSAM5-03-6 15:12 | | | | | | | |
| 7 | SSAM5-03-7 15:25 | | | | | | | |
| 8 | SSAM5-03-8 15:41 | | | | | | | |
| 9 | SSAM5-03-9 15:45 | | | | | | | |
| 10 | SSAM5-03-10 15:50 | | | | | | | |
| 11 | | | | | | | | Total depth 11.0'. |
| 12 | | | | | | | | |
| 13 | | | | | | | | |
| 14 | | | | | | | | |
| 15 | | | | | | | | |
| 16 | | | | | | | | |
| 17 | | | | | | | | |
| 18 | | | | | | | | |
| 19 | | | | | | | | |
| 20 | | | | | | | | |
| 21 | | | | | | | | |
| 22 | | | | | | | | |
| 23 | | | | | | | | |
| 24 | | | | | | | | |
| 25 | | | | | | | | |
| 26 | | | | | | | | |
| 27 | | | | | | | | |
| 28 | | | | | | | | |
| 29 | | | | | | | | |
| 30 | | | | | | | | |
| 31 | | | | | | | | |
| 32 | | | | | | | | |
| 33 | | | | | | | | |
| 34 | | | | | | | | |

DRB-ENVIRO BORING 2027.01.GPJ 2/11/11

Appendix B

ENVIRON Standard Operating Procedures

Standard Operating Procedure B-1: Soil Sampling with Direct-Push or Hollow-Stem Auger Samplers

Standard Operating Procedure B-1: Soil Sampling with Direct-Push or Hollow-Stem Auger Samplers

This standard operating procedure (SOP) is applicable to the collection of representative soil samples using a direct-push or hollow-stem auger sampling technique. The methodologies discussed in this SOP are generic in nature and may be modified in whole or part to meet the handling and analytical requirements of the contaminants of concern, as well as the constraints presented by site conditions and equipment limitations. Modifications of sampling methodologies will be documented in the appropriate field logbook and discussed in reports summarizing field activities and analytical results. For the purposes of this procedure, soils are those mineral and organic materials not submerged in water for an extended period of time sufficient to support aquatic life.

Sample Collection

The primary means for the collection of subsurface soil samples will be a direct-push technique using a Geoprobe® or equivalent driver. Direct-push soil samples will be obtained using a closed-piston soil sampler with a liner (or equivalent sampling system). If needed, a hollow-stem auger sampler may be used to collect soil samples. The sampler will be operated in accordance with the manufacturer's recommended operating procedures for the type of equipment used.

Discrete Soil Sampling Procedures

Soil samples will be collected at predetermined intervals based on specific data needs. Each discrete sample will be described in the field notebook using the Unified Soil Classification System (USCS) as described below. Soil samples that will not become composite samples will be placed directly in the appropriate sample containers using a clean plastic or metal spatula, or by using a clean gloved hand.

Subsamples selected for laboratory analysis will be placed in appropriate sample containers provided by the analytical laboratory, labeled, placed in an iced cooler, and stored in accordance with chain-of-custody requirements specified in the QAPP (Appendix A to the Final (100%) Design Report) until shipment to the laboratory (or laboratories) is arranged. Chain-of-custody records will be completed for all samples according to the methods described in the QAPP (Appendix A to the Final (100%) Design Report).

Discrete samples that will become aliquots of a composite sample will be covered or capped as soon as possible after collection if the compositing process is not completed immediately. Each sample container will be labeled and stored on ice pending the composite process.

Composite Soil Sampling Procedures

Composite samples will be prepared from the discrete samples following collection of the required number of discrete sample specified for the sampling area. Each discrete sample will be removed from the sample container and placed on a clean sheet of aluminum foil. After removing sticks, grass, stones, and other debris, each discrete sample will be separated into quarters – cores will be cut lengthwise into 4 equal portions, while disturbed samples will be homogenized and divided. Three of the four quarters of each sample will then be placed into

one of three individual foil pans. The fourth portion of the discrete sample will be placed in a plastic baggie, labeled, sealed, and stored separately for potential individual analysis.

The compositing process of quartering discrete samples will be repeated for successive discrete samples until each of the three pans contains one quarter of each discrete sample. The contents of each aluminum foil pan will then be thoroughly mixed either by hand or by using an electrical or mechanical mixer. Upon completion of the mixing process, the contents of each individual pan will then be combined into one clean pan and again thoroughly mixed, resulting in one homogeneous sample. The composite soil sample will then be placed in the appropriate sample containers, labeled, and placed on ice pending shipment to the laboratory.

VOC Sample Collection Procedures

Soil samples obtained for laboratory analysis of VOCs will be collected in compliance with SW-846 Method 5035. Each soil sample will be obtained directly from the sampling device (i.e., not homogenized) using an EnCore™ sampler or field preserved using Method 5035 compatible containers. A description of each sampling procedure is as follows:

EnCore Sampler

The EnCore™ sampler is a single use, commercially available device constructed of an inert composite polymer. EnCore™ uses a coring/storage chamber to collect either a 5-gram or 25-gram sample of cohesive soils. It has a press-on cap with a hermetically vapor tight seal and a locking arm mechanism. Three EnCore™ samplers shall be filled at each sample location using the following procedures:

- Place the EnCore™ sampler into the EnCore™ T-Handle tool.
- Push the sampler into the soil sample until the small o-ring on the plunger of the EnCore™ sampler is visible in the T-Handle viewing hole.
- Wipe off any excess soil from the coring body exterior using a clean paper towel.
- Place the cap on the end of the EnCore™ sampler and twist to lock the cap into place.
- Remove the sampler from the T-Handle and lock the plunger by rotating extended plunger rod fully counterclockwise until the plunger wings rest firmly against the plunger tabs.
- Place the label on the sampler and place the sampling into a labeled EnCore™ sampler bag and zip closed.
- Place the filled EnCore™ samplers in a cooler with ice for overnight shipment to the laboratory using standard chain-of-custody procedures. The soil samples must be prepared for analysis or frozen within 48 hours of sample collection.

Field Preservation

The procedures for the field preservation method are as follows:

- Push a one-time use plastic sampling tool such as a Terra Core™ sampler into the soil to be samples to collect an approximately 5-gram sample aliquot.
- Transfer the 5-gram aliquot to laboratory provided, pre-preserved, 40-milliliter vials containing a specific amount of methanol, sodium bisulfate, and/or organic-free water. The

number of vials provided with each preservative will vary by the laboratory performing the analysis. One unpreserved container shall also be filled to allow for laboratory calculation of the sample dry weight.

- Label each sample and place in a cooler with ice for overnight shipment to the laboratory using standard chain-of-custody procedures.

Sample Description and Field Documentation

After samples for chemical and physical analysis have been prepared, a visual soil or lithologic description of each sample will be made according to the USCS, and will be recorded in a bound log notebook. Each sampling location will be photographed, and the approximate location will be placed on a site map and recorded in the field notebook.

Residual soil from the compositing process and stored individual discrete sample portions will be disposed in accordance with the Sampling and Analysis Plan.

Equipment Decontamination

Drilling and support equipment will not come in direct contact with the samples, so cross-contamination of samples is not a concern. However, this equipment will likely come in contact with impacted soil and must therefore be decontaminated prior to moving from one location to another.

The drilling equipment used for soil sampling and monitoring well installation will be cleaned with high-pressure/hot water washing equipment prior to initiating the field investigation. The same procedure will be applied to all drilling equipment between each boring location. The cleaning will occur at a decontamination pad constructed at a suitable location(s) at the site. Water used for cleaning will be obtained from a local potable water source. Equipment subject to these decontamination procedures includes, but is not limited to, the following:

- Direct-push or hollow-stem auger drill rig.
- Direct-push or hollow-stem auger sampler components.

In addition, downhole equipment that comes in direct contact with samples will be decontaminated between each sample interval. This procedure will include washing with a nonphosphate detergent and rinsing with clean potable water.

If required, a piece of sampling equipment that comes in direct contact with soil samples (e.g., split-barrel samplers) will be selected for collection of field equipment blanks. After the equipment has been cleaned, it will be rinsed with DI water. The rinse water will be collected and submitted for analysis of all constituents for which the normal samples collected with the equipment are being analyzed.

Field blanks will be collected at the frequency specified in the QAPP (Appendix A to the Final (100%) Design Report).

Standard Operating Procedure B-2: Determining Hydraulic Conductivity Using an Aardvark Permeameter

1.0 PURPOSE

This Technical Procedure is to be used to establish a uniform procedure for executing a permeameter test.

2.0 APPLICABILITY

This Technical Produce is applicable to all persons or parties involved with permeameter testing using an Aardvark Permeameter.

3.0 DEFINITIONS

3.1 Saturated hydraulic conductivity (K_{sat}): An indicator of water flow rate in soil and is a key parameter for studying water flow and chemical transport through a soil profile.

3.2 Constant-head permeameter: Tool which measures soil-water infiltration rate by maintaining a constant depth of water in the borehole during the measurement period and measuring the rate of water supplied by the reservoir.

4.0 REFERENCES

Soil Moisture Equipment Corporation, December 2011. 2840 Operating Instructions: Aardvark Permeameter. (Exhibit A)

5.0 RESPONSIBILITY

5.1 Field Personnel performing permeameter testing shall be responsible for the proceeding with testing in compliance with this technical procedure.

5.2 Task Leader shall be responsible for:

- Direct supervision of personnel performing the test.
- Assurance that equipment and materials are available to permit accomplishment of the task.
- Determine appropriate time intervals between readings.

6.0 EQUIPMENT AND MATERIALS

6.1 Field notebook.

6.2 Model 2840K1PC & 2840K2PC Automated Aardvark Permeameter kits for shallow and deep measurements (>3.44 meters), respectively.

6.3 Field datasheets for manually recorded readings.

7.0 PROCEDURE

- 7.1 Perform site evaluation and select number and location of areas that are representative of the soils being tested.
- 7.2 Prepare the borehole(s) with suggested diameter of 10 centimeters (4 inches) with depths ranging from 20 centimeters (7.9 inches) to 15 meters (50 feet).
- 7.3 Assemble the Aardvark Permeameter Module (APM) and Reservoir Unit (RU) (as needed), along with the reservoir, scale, table, and tubing setup according to the instructions in the document *2840 Operating Instructions: Aardvark Permeameter*, pages 22.
- 7.4 Install the APM in the borehole by lowering it into the borehole using the tape, making sure that it is touching the bottom of the borehole. Secure the tape using the tape holder and tubing, being sure to never let the tubing hanging directly from the Reservoir Valve.
- 7.5 Determine and record the following parameters: depth of the borehole; height of the Reservoir from soil surface; vertical distance between the APM Floating Valve and Reservoir (parameter D).
- 7.6 Fill out the upper section of the data sheet; record initial water level/volume in the Reservoir and the time in the first row of the table.
- 7.7 Open the reservoir valve, establishing a constant water head. Record Reservoir water level and time after appropriate interval, as determined by information found in the document *2840 Operating Instructions: Aardvark Permeameter*, page 20.
- 7.8 Add more water to the Reservoir, if needed. Record Reservoir water level and time right before and after refilling.
- 7.9 Monitor the Steady Water Consumption Rate (R) being calculated via the SimplyDATA Software Suite application. If not using the software, the Steady Water Consumption Rate can be determined using the formula found in the document *2840 Operating Instructions: Aardvark Permeameter*, page 20. The measurement is complete when the Water Consumption Rate does not change over several consecutive readings. In the Steady Water Consumption Rate stage, the steady "Water Consumption Rate" is equivalent to the soil Steady Flow Rate (Q) or Soil-Water Stead Infiltration Rate, which is the key parameter to calculate saturated hydraulic conductivity.
- 7.10 Utilize the SimplyDATA Software Suite to perform all the measurements and calculations for saturated hydraulic conductivity automatically, referring to the "SimplyDATA Software Suite Operating Instructions" for more details. The calculations can also be performed manually according to the instructions on pages 31-33 of the document *2840 Operating Instructions: Aardvark Permeameter*.

DETERMINING HYDRAULIC CONDUCTIVITY USING AN AARDVARK PERMEAMETER

EXHIBIT A: 2840 Operating Instructions: Aardvark Permeameter

2840

OPERATING INSTRUCTIONS

Aardvark Permeameter

December 2011

Model 2840K2 Series

Manual Aardvark Measurements
(0.2 ml accuracy, 50 ft operating depth)



2840K2 Aardvark Kit complete in case

Model 2840K2RIF & PC Series

Automated Aardvark Measurements
(0.2 ml accuracy, 50 ft operating depth)



2840K2RIF Aardvark Kit complete in case

Models 2840K1 and 2840K2 for Quick and Easy K_{sat} Measurements

The Aardvark Permeameter is an easy to use instrument to quickly and accurately measure in-situ saturated water flow. Accurate evaluation of soil hydraulic conductivity and matrix flux potential can be made in almost all types of soils.

Model 2840K#PC and 2840K#RIF for Automated K_{sat} Measurements (#: 1 or 2)

If you purchased the PC or RIF Kit, this will help automate taking K_{sat} readings with the addition of a digital scale 7201W10, either a user-supplied PC or Soilmoisture's Record It in a Flash (RIF) unit.

Table of Contents

| | |
|---|----|
| UNPACKING | 3 |
| CAUTIONS & WARNINGS | 3 |
| WARRANTY & LIABILITY | 3 |
| ACQUAINT YOURSELF WITH THE PARTS | 4 |
| Models 2840K1 & 2840K2 Aardvark Permeameter - For Quick and Easy K_{sat} Measurements | 4 |
| Models 2840K1PC & 2840K2PC Automated Aardvark Permeameter | 5 |
| Model 2840K1RIF & 2840K2RIF Automated Aardvark Permeameter with "Record It in a Flash" (RIF) | 6 |
| AARDVARK GENERAL SPECIFICATIONS | 7 |
| THEORY OF OPERATION and DEFINITIONS | 8 |
| REQUIREMENTS PRIOR TO USE | 9 |
| Operating Model 2840K1 and Model 2840K2 (Quick and Easy) | 11 |
| Aardvark Pressure Regulator Unit | 11 |
| Components of the Aardvark Permeameter Module (APM) | 11 |
| Assembly of your Reservoir Unit | 12 |
| Assembling Aardvark Table | 12 |
| Placement of Table | 13 |
| Connecting Tubing and Suspension Line to APM | 13 |
| Installing APM in Borehole | 15 |
| Documentation Prior to Performing a Measurement | 19 |
| Making a Reading | 20 |
| Operating Model 2840K1PC and Model 2840K2PC (automated readings using a PC) | 22 |
| Making a Reading | 24 |
| Operating Model 2840K1RIF and Model 2840K2RIF (for automated measurements) | 25 |
| Making a Reading | 25 |
| USEFUL HINTS DURING NORMAL USE | 26 |
| TROUBLESHOOTING | 27 |
| GENERAL CARE AND MAINTENANCE | 28 |
| Disassembling the Aardvark Permeameter Module | 28 |
| Cleaning the Aardvark Permeameter Module | 28 |



| | |
|--|-----------|
| USE AND APPLICATION OF PRODUCT OPTIONS | 29 |
| CALCULATIONS AND APPLICATIONS | 31 |
| Using SimplyDATA Software Suite for manually recorded data | 31 |
| Manually Performing the Calculations | 32 |
| REPLACEMENT PARTS LIST | 35 |
| APPENDIX A | 36 |



UNPACKING

The Aardvark Permeameter Kit was thoroughly tested before shipment. When packed, it was in perfect working order. Unpack with care making sure you remove all packing material. Follow the instructions carefully in order to assure long, trouble-free service.

Any damage found upon receipt should be reported immediately to the transport carrier for claim. It is important to save the shipping container and all evidence to support your claim. Be sure to read all operating instructions thoroughly before operating the unit.

CAUTIONS & WARNINGS

In order to avoid damage to the device and injury, use only those tools included. When completely full, the water container is relatively heavy and additional weight should be taken into account. In order to prevent damage to scale or other parts of the system, make sure that the table is placed on a stable hard surface. Do not use larger volume water containers or replacement containers other than those supplied with your unit.

WARRANTY & LIABILITY

Soilmoisture Equipment Corp. (SEC) warrants all products manufactured by SEC to be free from defects in materials and workmanship under normal use and service for twelve (12) months from the date of invoice provided the section below has been met.

Soilmoisture Equipment Corp. (SEC) is not liable for any damages, actual or inferred, caused by misuse or improper handling of its products. SEC products are designed to be used solely as described in these product operating instructions by a prudent individual under normal operating conditions in applications intended for use by this product.



ACQUAINT YOURSELF WITH THE PARTS

Model 2840K1 & 2840K2 Aardvark Permeameter - For Quick and Easy K_{sat} Measurements

The Aardvark Permeameter Kit (2840K1 for measurements shallower than 3 m (11 ft) and 2840K2 for measurements deeper than 3 m) has everything needed for conducting the measurement and is simple to install and use. Since it has no electronic parts, it can be used everywhere from laboratories to remote areas. At the same time, the kit can be used with a personal computer (not included) and using the SimplyData Software Suite, there would be no need for manually calculating the parameters.

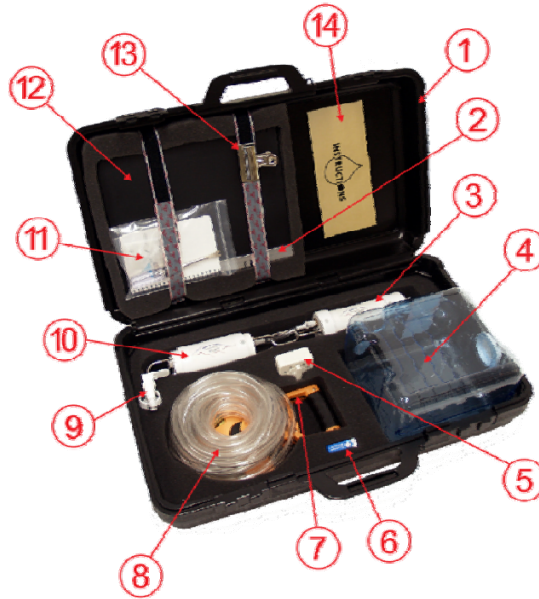

Fig. 1. Illustration of 2840K1 / 2840K2 components

- | | |
|--|--|
| 1. Aardvark Carrying Case | 8. Connecting Tube, 15 m (50 ft) |
| 2. Tape Holder | 9. Reservoir Outlet Assembly |
| 3. Aardvark Permeameter Module | 10. Aardvark Pressure Regulator Unit (not included in 2840K1). |
| 4. Aardvark Reservoir | 11. Support Package |
| 5. Countdown Timer | 12. Aardvark Table |
| 6. Flash drive loaded with SimplyData Software Suite | 13. Tubing Clip |
| 7. Measuring / Suspension line, 15 m (50 ft) | 14. Operating Instructions |



Aardvark Support Package

1. Hose Clamp
2. SEC 2 Color Pen
3. SEC LED Flash Light
4. Tubing Clip
5. Pin Access Tool
6. Silicon Grease
7. Quick Connection Insert
8. Tubing Barbed Connector
9. Plastic Connection Pin
10. SEC All Weather Notebook
11. SEC Measuring Tape

Model 2840K1PC & 2840K2PC Automated Aardvark Permeameter

These kits consist of an Aardvark Permeameter Kit (2840K1 for measurements shallower than 3 m (11 ft) or 2840K2 for measurements deeper than 3 m) and a Digital Scale (7201W10) which can be connected to a personal computer (not included) and record the measurements automatically and accurately, using the SimplyData Software Suite. There is no need to manually record data or perform the calculations. It is also possible to view the real-time graph of soil-water flux rate during the measurement period. This kit is a perfect option for laboratory experiments where it can easily be connected to a personal computer. It can also be used in the field using a portable laptop computer. This model can even be used to take manual readings (when no PC is available). Using the digital scale significantly adds to the accuracy of readings.



Fig. 2. Photo of 2840K1PC / 2840K2PC

- | | |
|-----------------------------|---|
| 1. Aardvark Permeameter Kit | 4. SimplyData Digital Scale |
| 2. Scale Carrying Case | 5. Scale Power Supply (not shown) |
| 3. USB Cable | 6. Scale Operating Instructions (not shown) |

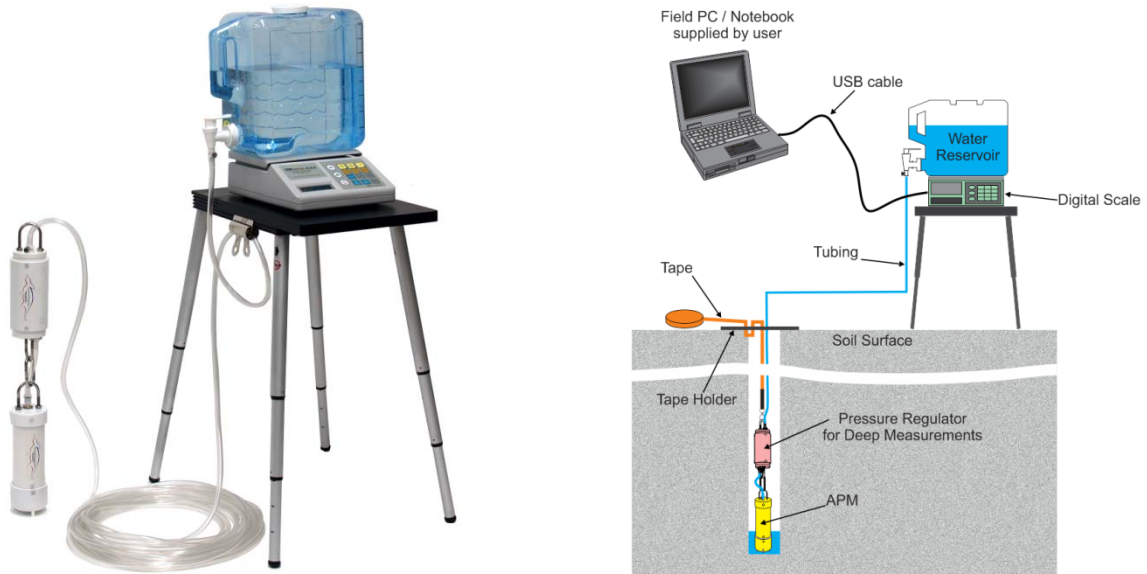

Fig. 3. Right: Model 2840K2PC. Left: Illustration of the model components: a USB cable connects the Digital Scale to a PC (not included). Real time graphs and calculations and data logging are the main features of SimplyData Software Suite installed on your PC. The kit also can be used without a PC (manual data recording and calculation).

Model 2840K1RIF & 2840K2RIF Automated Aardvark with "Record It in a Flash" (RIF)

Record It in a Flash (RIF) is the answer to the common cases when an accurate and automated permeameter is needed for use in outdoor conditions or remote areas and it is not convenient to use a PC. The kit consists of an Aardvark Permeameter Kit (2840K1 for measurements shallower than 3 m (11 ft) or 2840K2 for measurements deeper than 3 m) a Digital Scale (7201W10) that connects to an RIF Unit (7205) which eliminates the need for a dedicated personal computer. Record It in a Flash automatically records the Digital Scale measurements and performs the calculations. It also recognizes the end of the measurement period and alerts the user. The data can be transferred later to a PC or with the SimplyData Software Suite it is easy to manage the data files and generate graphs.



Fig. 4. Photo of 2840K1RIF (10 ft operating depth) or 2840K2RIF (50 ft operating depth) components.

- | | |
|---|-------------------------------------|
| 1. Aardvark Permeameter Kit (2840K1 for 2840K1RIF and 2840K2 for 2840K2RIF) | 4. RIF Carrying Case |
| 2. Digital Scale Package | 5. Four "C" size Alkaline batteries |
| 3. Record It in a Flash unit | 6. Digital Scale Power Supply |

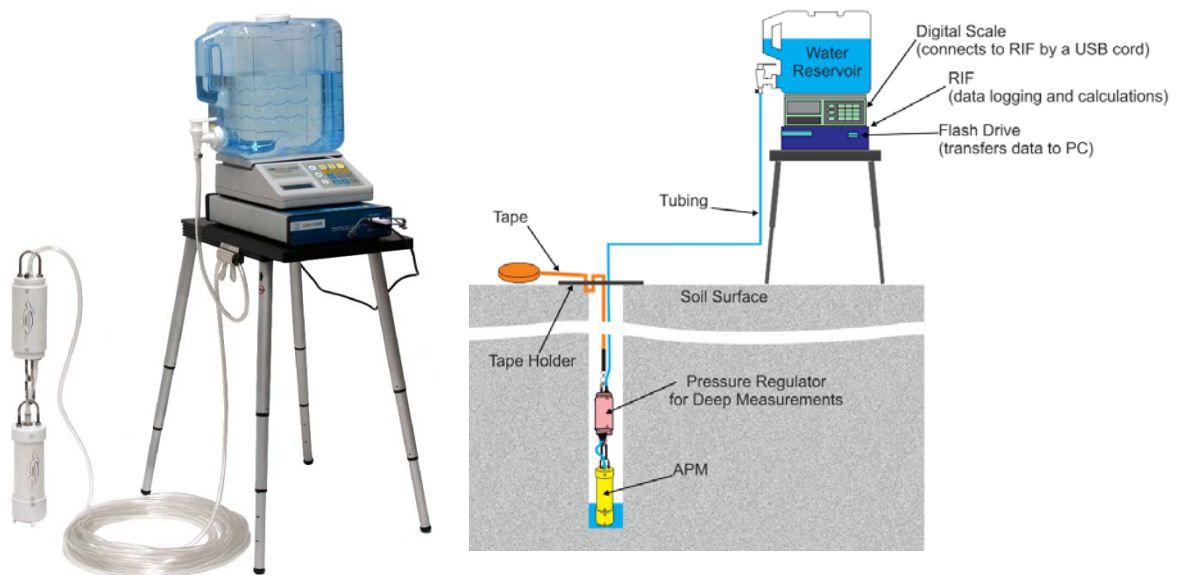

Fig. 5. Right: Model 2840K2RIF Setup. Left: Illustration of the model components. RIF logs the data received from Digital Scale. It uses this data to calculate K_{sat} coefficient and other related values. RIF also supplies the Scale power.

AARDVARK GENERAL SPECIFICATIONS

2840 Aardvark-1000 Permeameter Unit (comes in 2840K1, 2840K2, 2840K1PC, 2840K2PC, 2840K1RIF and 2840K2RIF)

Diameter (OD x L): 7.6 x 35.6 cm (3" x 14")
Minimum water supply rate (with 3 ft of water overhead pressure): 1000 ml / min (0.26 gal / min)
Maximum operational depth 15 m (50 ft)

2841V2.0 Aardvark Reservoir (comes in 2840K1, 2840K2, 2840K1PC, 2840K2PC, 2840K1RIF and 2840K2RIF)

Volume: 8 liter (2 gal) weight when full about 8 Kg (17.6 lbs.)
Dimensions (L x W x H): 25 x 18 x 23 cm (10" x 7" x 9")

2842 Aardvark Table (comes in 2840K1, 2840K2, 2840K1PC, 2840K2PC, 2840K1RIF and 2840K2RIF)

Table Top Dimensions (L x W): 38 x 26 cm (15" x 10½")
Height: from 33 to 73 cm (13" to 29")

2843 Aardvark Carrying Case (comes in 2840K1, 2840K2, 2840K1PC, 2840K2PC, 2840K1RIF and 2840K2RIF)

Dimensions (L x W x H): 71 x 43 x 18 cm (28" x 17" x 7")
Weight When Full: 6.6 Kg (14.6 lbs.)

7201W10 10Kg Digital USB Scale (comes in 2840K1PC, 2840K2PC, 2840K1RIF and 2840K2RIF)

Maximum load: 10 Kg
Resolution: 0.2 g
Dimensions (L x W x H): 26.4 x 20.1 x 7.9 cm (10.4" x 7.9" x 3.1")
Platform Size: 5.7" x 7.5"
Weight 1.05 Kg (2.3 lbs.)
Power Consumption: 0.035 W

7205 Record It in a Flash (RIF) unit (comes in 2840K1, 2840K2, 2840K1PC, 2840K2PC, 2840K1RIF and 2840K2RIF)

Dimensions (L x W x H): 35.6 x 21.6 x 5.1 cm (14" x 8.5" x 2")
Weight: 1.65 Kg (3.6 lbs.)
Max. Power Consumption: 0.8 W
Batteries: 4 'C'-size Alkaline
AC-DC Wall Adapter: 6VDC @ 1A, positive center

8010SFAGB02 SimplyData Software Suite (comes in 2840K1, 2840K2, 2840K1PC, 2840K2PC, 2840K1RIF and 2840K2RIF)

System requirements:
Windows 2000 or newer,
Minimum display resolution of 1024x768 and
.NET Framework (included in Windows Vista and newer)

2840-2000 Aardvark Regulator Unit (comes in 2840K2, 2840K2PC and 2840K2RIF)

Maximum operating range: 34 KPa (5 PSI)
Minimum operating range: 690 KPa (100 PSI)
Diameter (OD x L): 7.6 x 31 cm (3" x 12")
Operational depth with Aardvark unit: from 3 m (10 ft) to 15 m (50 ft)



THEORY OF OPERATION and DEFINITIONS

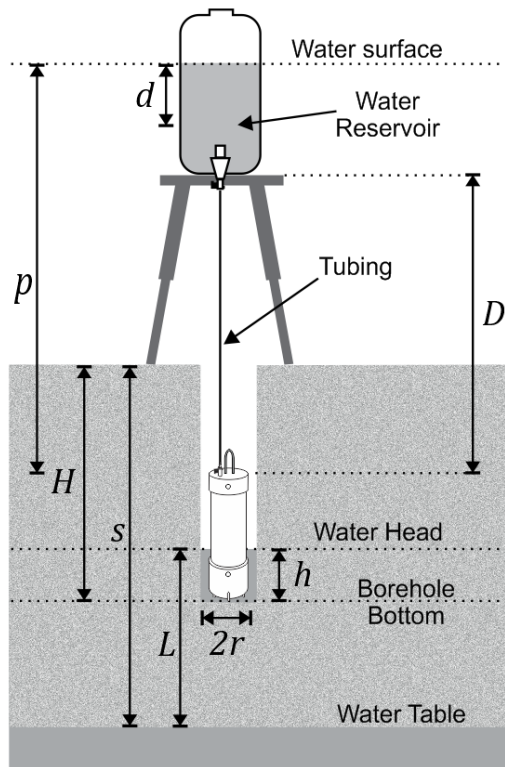

Fig. 6. Schematic of a Standard Setup of an Aardvark Permeameter. Where d is drop in reservoir water level, D is vertical distance between Reservoir and APM, H = borehole depth, r = borehole radius, h = constant water head height in borehole, p = vertical distance between water surface in reservoir and constant water head, s = water table depth and L = the vertical distance between constant water head and water table / impervious layer.

Saturated hydraulic conductivity (K_{sat}) is an indicator of water flow rate in soil and is a key parameter for studying water flow and chemical transport through a soil profile. These measurements can be vital to scientific and engineering studies. For example, it can be used in leach line placement in rural sewer systems and determine limits of rain/runoff conditions, and the ability of holding ponds to retain water.

The Aardvark is a constant-head permeameter. It means that the depth of water in borehole (h) does not change during the measurement period (Fig. 6). As a result, the measurement conditions remain constant during the measurement period. The rate of water supplied corresponds to soil infiltration rate from the bottom and side surfaces of the testing borehole.

The Aardvark Permeameter estimates soil hydraulic conductivity using the amount of supplied water (determined using d) measured at equal time intervals (Fig. 6). This is equivalent to the amount of water that was infiltrated by soil. Soil-water infiltration rate is the amount of percolated water over time which is equivalent to the reservoir flow rate (see equation below).

$$\text{reservoir flow rate} = \frac{\text{reservoir water change}}{\text{time}}$$

The measurement ends when the reservoir flow rate (soil-water infiltration rate) does not change over several consecutive readings. Soil hydraulic conductivity (K_{sat}) then can be calculated using this steady flow rate (Q). For more details see section "Calculations and Applications".

REQUIREMENTS PRIOR TO USE

Before making a measurement with the Aardvark Permeameter (APM) in the field, it is recommended to perform a site and soil evaluation, prepare a well hole, assemble the Permeameter, fill the Reservoirs, and place the Permeameter in the well hole. Upon arrival at the site, the user must evaluate the site with regard to topography, general soil appearance, intended application, and select the number and location of areas that are representative and intended for testing of the soils under study.

The suggested borehole diameter is about 10 cm (4"). Your APM will establish a stable water head height in the borehole. This standard combination is practical for almost all soils. For soils with very fine textures such as heavy clays a wider borehole can be used (not suggested) as well as higher head heights. Conversely, open textured soils such as coarser sands may do better with smaller borehole diameters.

The Aardvark Permeameter is designed to be installed in a borehole in soil profile from 20 cm (7.9") to 15 m (50 ft) depth. Therefore before installing the Aardvark Permeameter a borehole will need to be prepared. The equipment needed to dig a borehole depends on the width and depth desired. Our Model 0237D10L12 contains all the required tools and instructions to auger and clean a borehole with a 10 cm (4") width (recommended width for the Aardvark) down to a 4 m (12 ft) depth.

This set includes:

1. Loam Soils Auger
2. Auger Extension (30")
3. Well Prep Brush
4. Carrying bag
5. Sizing Auger
6. Auger Handle



Fig. 7. Model 0237D10L12 components.

If you are using the Model 2840K1, 2840K2, 2840K1PC, or 2840K2PC and want to record the readings manually, we have provided a data sheet in Appendix A for your convenience. We suggest a rugged pen or pencil for taking readings and notes. As part of your Aardvark Kit we have supplied a Countdown Timer to take readings on a scheduled basis. It is also advisable to have access to additional water in order to refill the reservoir in porous soils and for multiple tests. Please note that water used in permeameter tests should be clear and free of debris as it could have an effect on internal regulator functionality and on weight of water use calculations; therefore clean pure water is advised for all testing.

On windy days it may be difficult to read the water level in Reservoir. Wind also may have a negative effect on Digital Scale accuracy. In the case of severe wind the system can be set up inside a tent.

Operating Model 2840K1 and Model 2840K2

Aardvark Pressure Regulator Unit (RU)

In these instructions, we refer to “Shallow Measurements” for measurements with a D (Fig. 6) less than 3.44 m (11.3 ft) using only the Aardvark Permeameter Module (no RU in line). We also refer to “Deep Measurements” - measurements with a D more than 3.44 m (11.3 ft) using the RU and APM in line.

For Deep Measurements use the RU in line with the Aardvark Permeameter Module (Shallow Measurements do not require the use of an RU; the APM can be connected directly to the Reservoir). Install the RU above the APM (with minimum vertical distance). If you need to perform a Deep Measurement, follow these steps:

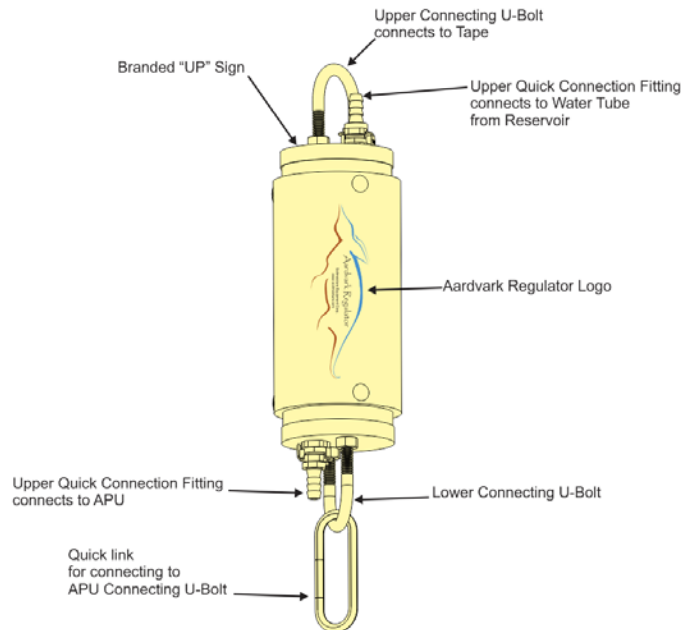

Fig. 8. Aardvark Regulator Unit

Determine input and output of the RU. The RU is completely symmetrical, so it is very important to install the RU right side up. (The Aardvark in the Logo should be “crawling out of the hole”). The RU input tube is towards the Aardvark head in logo (up). The input tube connects the RU to the Reservoir. The RU output tube is towards Aardvark’s tail in the logo (down). The RU output (Fig. 8) connects the RU to the APM. If, for any reason, the Aardvark Regulator logo cannot be clearly seen on the RU, there is a Branded “UP” sign on the top of the RU that can be used for proper orientation.

Connect the Quick Link to the RU’s Lower U-Bolt. The Quick Link provides an easy and secure connection between the two units.

Connect the RU output to the APM Quick Connection using the RU-APM connection tube.

Connect the RU input to the Reservoir using the Connection Tube.



Components of the Aardvark Permeameter Module (APM)

The Aardvark Permeameter Module is shipped completely assembled and ready to use (Fig. 9 left). The Aardvark Permeameter Module has three major parts: The Head Cap, The Body Tube and The Dispersive End Cap (Fig. 9, right).

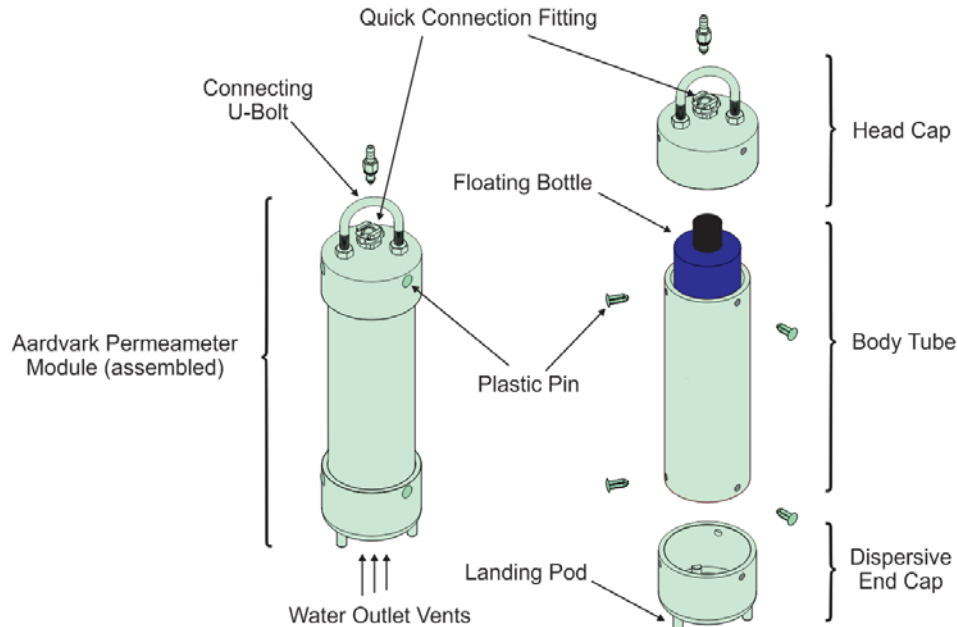

Fig. 9. Left: assembled Aardvark Permeameter Unit. Right: Major Components of APM.

On the top of the Head assembly there is a stainless metal U-Bolt (UB) for connecting to the Suspension Line (Measuring Tape) or Quick Link of the Pressure Regulator (Fig. 8). It is used for hanging and lowering the APM in a Borehole. The Quick Connection (QC) provides an easy and secure connection between the Head Assembly and Connecting Tubing (Fig. 9 right).

The Body Tube creates a head height about 9 to 10 cm deep (see section “*Installing APM in a Borehole*” for more details).

The Dispersive End Cap lands on the bottom of Borehole and serves as a base for the Permeameter and disperses the energy of out-flowing water from the vents and minimizes the risk of erosion of Borehole surfaces.

Assembling your Reservoir Unit:

Connect the Quick Connection provided in the Kit to the end of Tubing (Fig. 10a). The other end of Tubing connects to the APM or RU (if using an RU).

Connect the Valve to Reservoir and make sure the Valve is closed (Fig. 10b).

Connect the Quick Connection (Tubing) to Reservoir Valve (Fig. 10c).

Fill the Reservoir with clean water.

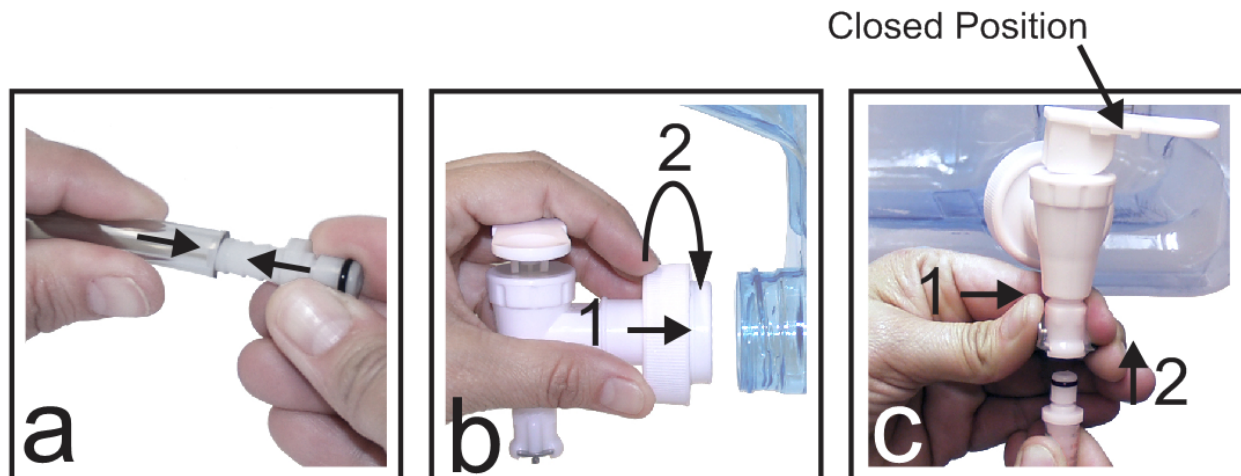

Fig. 10. Reservoir Assembly.

Assembling Aardvark Table

Slide open the Aardvark Table Cover (Fig. 11a).

Open each telescopic leg to the proper length and twist it until it is locked at the desire length (Fig. 11b). Use only 2/3 of the table height (56 cm) to add to its strength and stability. This height provides the proper amount of overhead pressure for shallow measurements.

Place the O-ring in the proper position. The small O-ring on the top of the leg may be a little off-set (Fig. 11c) and the leg may not be positioned correctly in the hole. Make sure the O-ring is in its proper place (Fig. 11d).

Put the top of each leg in its base under the table top (Fig. 11e) and turn it until it locks. Please note that the legs are not completely perpendicular with the table top.

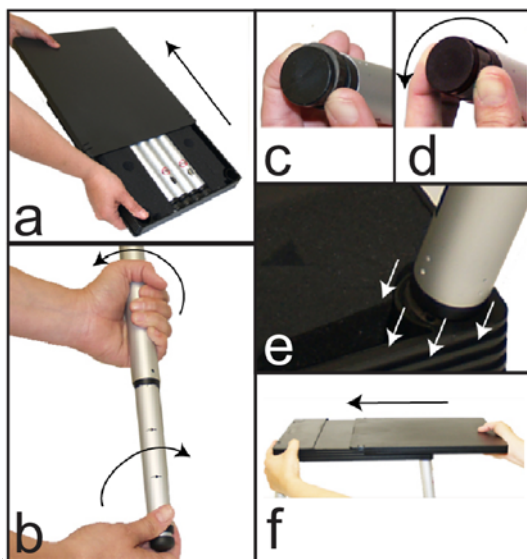

Slide the cover over the table top (Fig. 11e). It is important to place the Table on a sturdy surface so the legs do not penetrate into the soil and the Table is steady and level.

Table Placement

Place the Table next to the borehole. Try to position the Reservoir directly over the Borehole opening. This will eliminate excess water in the Connecting Tubing and allow for the most direct path between the Reservoir and the APM in the hole. Clear excess leaves, dried grass, and soil from the edge of the borehole and around the Table to prevent these materials from falling down the borehole during the test. Do not step on or across the well hole during the testing process.

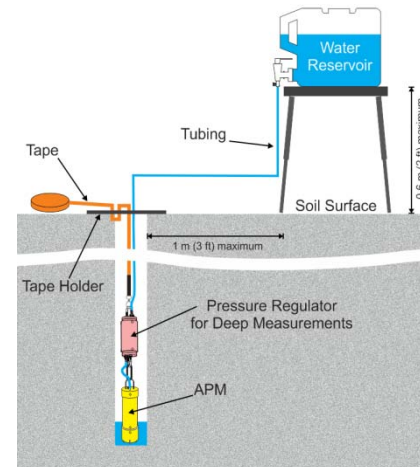

Connecting Tubing and Suspension Line

You may need to cut the Tubing according to the distance between the Reservoir and the APM (Fig. 12). Should you need to cut the Tubing, always cut a few feet longer than what you need. If you cut the Tubing too short, you can always reconnect the two pieces using a Tubing Coupler provided in the support kit.



Fig. 13. connecting two pieces of tubing using a Tubing Coupler.

Connect the QC fitting to the end of Tubing. Make sure that the fitting is fully inserted to prevent leaking (Fig. 14a). Do not use lubrication. This will increase the risk of leakage or the tubing may disconnect under pressure in Deep Measurements.

Connect the fitting to its base. Depending on the depth of your measurement, the Tubing from the Reservoir can either be connected directly to the APM (for Shallow Measurements) or to the RU (for Deep Measurements). Push in the small lever on the side of the base and connect the fitting (Fig. 14b). It is important to make sure that Tubing does not leak water.

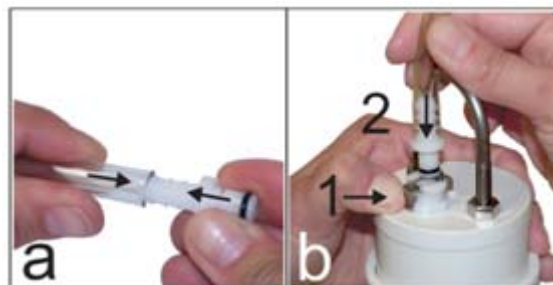

Fig. 14. Connecting the Quick Connection to the RU.

Connect the Tape Hook (Fig. 17). For Deep Measurements you will need to add the Pressure Regulator Unit in the line above the APM Unit (Fig. 16 right). Note that when the APM hangs from the Tape (with no Regulator Unit in the line), the numbers on the Tape show the distance to the very bottom of the APM. When the Regulator Unit is added in the line, it adds 30.5 cm (one foot) to the total length (Fig. 16 right). Please also note that one side of the Tape is in meters/centimeters and the other side in feet and tenths of a foot (not inches).



Fig. 15. Connecting Tape Hook to RU.

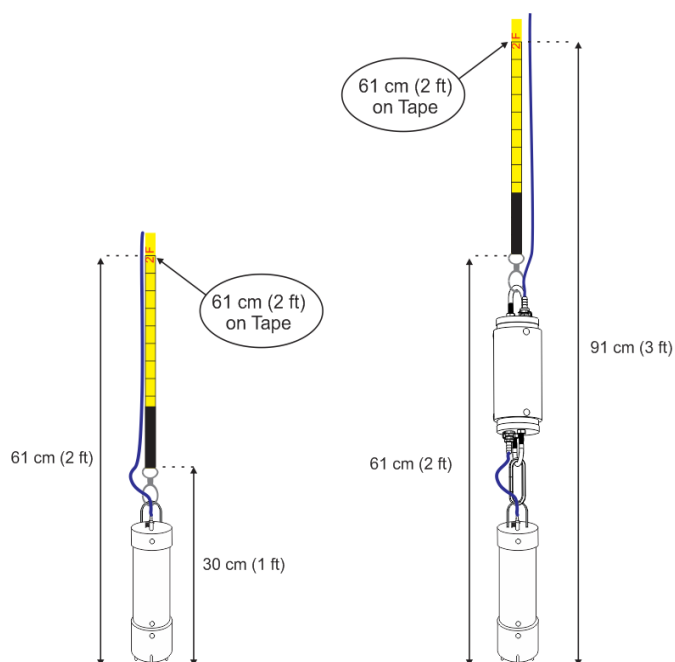

Fig. 16. Illustration of numbers on Tape. Left: APM without Regulator in the line (Shallow Measurements), right: APM with Regulator in the line (Deep Measurements).

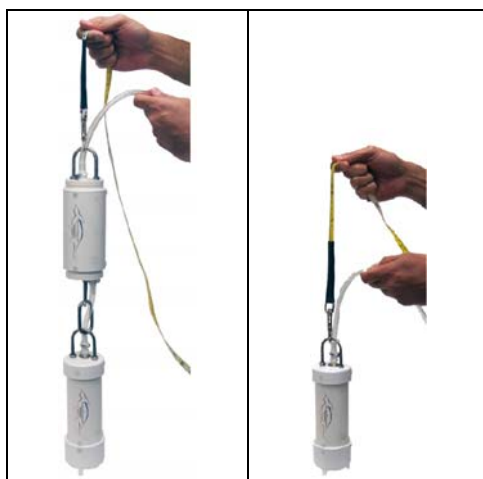

Fig. 17. Left: RU and APM are used for Deep Measurements. Right: for shallow measurements (less than 3 m or 11 ft depth) only APM is used.

Installing the APM in the Borehole

Standard Method:

After preparing the well and assembling the Table and Reservoir, connect the APM and Reservoir with their Tubing, and then lower the APM in the Borehole. The standard procedure is to make sure that APM is touching the bottom of the Borehole.



Fig. 18. Lowering RU and APM in borehole. Note do not hang from Tubing.

Carefully approach the Borehole Opening. Keep your feet away from the opening of the borehole as much as possible in order to prevent collapsing the upper parts of Borehole.

Using the Tape, carefully lower the APM into the Borehole until it reaches the bottom. It should touch the Borehole bottom and hang from the Tape at the same time (Tape is not slack). Note that if the APM is not in a vertical position, it may not work properly.

Secure the Tape using the Tape Holder when you feel the unit has touched the bottom of the borehole (Fig. 19).

Secure the Tubing. Never let the Tubing hang directly from the Reservoir Valve. It may tip the Reservoir over in Deep Measurements. The Tubing is relatively heavy when filled with water. This is especially important when you are using the Digital Scale. Use the Tubing Clip provided in the Kit to secure the Tubing. See Fig. 5 for the proper way to secure the Tube with the Tubing Clip.



Fig. 19. Tape secured using Tape Holder.

Secure the Borehole opening to prevent collapsing the upper parts of the well.

Record the depth of Borehole using Tape. When the APM is hanging in the Borehole, the numbers on Tape represent the distance from bottom of the APM (bottom of borehole). If the RU is in line, add another 30.5 cm (1 ft) to the Tape reading (Fig. 16).

Record the height of Reservoir (Table top) from soil surface. Use the Soilmoisture measuring tape provided in the Support Package.

Determine parameter D (Fig. 6). It is the vertical distance between the APM Floating Valve and Reservoir.

$D (cm) = \text{Depth of Borehole (cm)} <plus> \text{Height of Reservoir from Soil Surface (cm)} <minus> 18.5 (cm)$
 $D (inch) = \text{Depth of Borehole (inch)} <plus> \text{Height of Reservoir from Soil Surface (inch)} <minus> 7.25 (inch)$

Determine the water head height. In Shallow Measurements ($D < 3$ m), the APM overhead pressure changes due to changes in D (Fig. 6). This is a small amount of change from about 9 to 10 cm, 3.5 to 3.9 inches. Knowing parameter D (previous step) it is possible to accurately calculate the height of water head (h):

$h (cm) = 9.0 + 0.003D (cm)$
 $h (inch) = 3.5 + 0.04D (ft)$

The water level change in the Reservoir has a negligible effect on water head height (about 0.002 cm per each cm change in water level in the Reservoir). Therefore there is no need to adjust for the effect of water level change in the Reservoir in calculations.

For Deep Measurements (when $D \geq 3$ m (11 ft) and the RU is used), head height is always constant at 10.1 cm (4.0").

Raised Method Installation

In this method, the bottom of the APM does not land on the Borehole floor and it hangs from the Tape (never hang the APM from Tubing). In the Raised Method, the height of water head is determined by the length of the hanging part of Tape. This method may have some limited applications. For example, in soils with very low hydraulic conductivity raising the water head height will increase the borehole active surface area (the area that is in contact with water) and decrease the time needed for performing the measurement. It also increases the accuracy of measurements.

Although the Raised Method gives the user more flexibility in establishing different head heights, it is a little more complicated than the Standard Method.

Using the Raised Method in soils with high hydraulic conductivity can be problematic. The APM has been designed to create a small head height (about 10 cm).

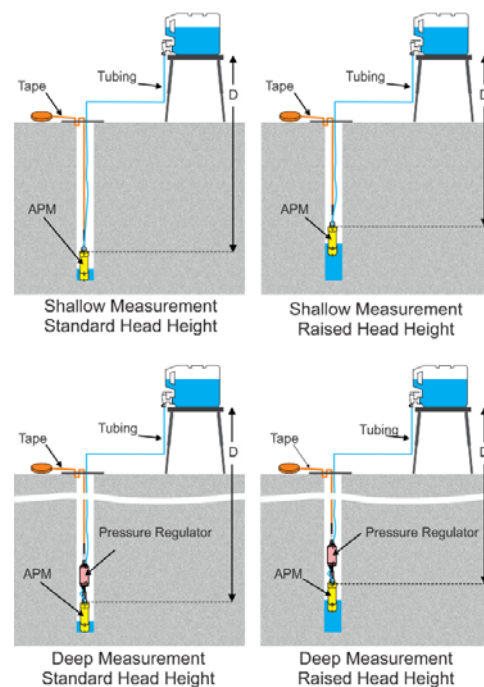

Fig. 20. Creating Standard (right figures) and Raised (left figures) head heights. Note that D is less than 3.44 m (11.3 ft) in Shallow Measurements while it is greater than 3.44 m (11.3 ft) in Deep Measurements.

Assuming the Borehole has the standard diameter of 10 cm (4"), the APM water supply would be sufficient to reach the water head in a short period of time. Using the Raised Method, the excess volume of the Borehole must be filled with Reservoir water and it takes more water and time to establish the water head height (in comparison with the Standard Method).

The Standard Method is more reliable since the water head depth is more accurate. In the Raised Method, there would be more Borehole erosion since water falls from the outlet vent in the borehole and, depending on the soil type and the distance of APM from the bottom of the hole, may cause significant erosion.

Carefully approach the Borehole Opening. In order to prevent collapsing the upper parts of the Borehole; try to keep clear from the Borehole opening as much as possible.

Using the Tape, carefully lower the APM into the Borehole until it reaches the bottom.

Secure the Tape using the Tape Holder (Fig. 19).

Secure the Tubing. Never let the Tubing directly hang from the Reservoir Valve. It may tip over the Reservoir in deep measurements. The Tubing is relatively heavy when filled with water. It is especially important when you are using Digital Scale. Use the Tubing Clip provided in the Kit. See Fig. 5 for the proper way to secure the Tube with the Tubing Clip.

Record the height of the Reservoir from the soil surface. Use the Soilmoisture Measuring Tape provided in the Support Package.

Record the depth of Borehole using the Tape. Remember that the numbers on the Tape represent the distance from the bottom of the APM (bottom of borehole). If the RU is in line, add another 30.5 cm (one ft) to the Tape reading (Fig. 16).

Raise the APM to the desired height considering that the water height would be equal to the raising height plus an additional height of about 9 to 10 cm (3.5 to 4.0"). Record the amount of the APM Raise for future reference.

Determine the depth of the APM. Remember that the number on the tape represents the distance to the bottom of the APM (if an RU is in the line, add another 30.5 cm (1 ft) to the number). Also note the distance between the bottom of the APM and its float valve is 18.5 cm (7.25"). Therefore the depth of the APM (actually the depth of its water valve) is equal to the number read on the tape at the borehole opening minus 18.5 cm (7.25"). If an RU is also in line, add another 30.5 cm (1 ft) to the number.

Calculate the parameter D (Fig. 6). It is the vertical distance between the APM unit and the Reservoir.

D (cm) = Depth of APM (cm) <plus> Height of Reservoir from Soil Surface (cm)

D (inch) = Depth of APM (inch) <plus> Height of Reservoir from Soil Surface (inch)

Determine the water head height. In a Shallow Measurement ($D < 3.44$ m, 11.3 ft), the water head height changes in small amounts (between about 9 to 10 cm or 3.5 to 4.0"). Knowing parameter D (previous step) it is possible to accurately calculate the height of water head (h):

h (cm) = 9.0 + 0.003D (cm) + APM Raise (cm)

h (inch) = 3.5 + 0.04D (ft) + APM Raise (inch)

For deep measurements (when $D \geq 3$ m (11 ft) and an RU is used), head height is always constant at 10.1 cm (4.0").

Note: Water level change in the reservoir has a negligible effect on water head height (about 0.007 cm per each cm change in water level in the Reservoir). Therefore we do not consider the effect of water level change in the Reservoir in our calculations.

Documentation Prior to Performing a Measurement

Appendix A is a sample datasheet that can be used for recording the measurements. For each sampling site, write the name and address (or lat/long) of the location, date, soil type and structure, borehole diameter, water head height, borehole depth, and water table depth. One can also record water temperature and sampling horizon description (optional). It is important to note that there are several standards and methods for calculating K_{sat} .

Making a Reading

Fill out the upper section of the data sheet provided in Appendix A (A sample data sheet is provided in Table 1).

Record the initial water level/volume in the Reservoir under column “Water Level in Reservoir” and the time under column “Time” in the first row of the table.

Open the Reservoir Valve. Depending on the Borehole’s dimensions and soil permeability, it may take from less than one minute to several minutes before establishing a constant water head. Boreholes wider than 10 cm (4”) would need considerably more time to establish a constant water head. Also water heads higher than the standard height need more time. In Shallow Measurements, since the overhead pressure from the Reservoir is low, it will take more time to achieve a constant water head.

Record the level of Reservoir water and time after appropriate interval. Use the Countdown Timer provided in the Support Kit. The time interval between recordings depends on the diameter of the Borehole, soil type and texture.

In soils with coarse textures the infiltration rate is higher and therefore smaller intervals are more suitable (between 1 to 5 min). Depending on method of calculation and considering that each increment on the Reservoir body is translated to 100 ml of water, for measuring a K_{sat} as low as 10^{-7} to 10^{-8} , a 60-minute sampling interval would be needed (assuming that the Borehole dimensions are standard). Also a deeper borehole or a larger Borehole diameter increases the total infiltration rate (Q) of the well and a smaller time interval can be used.

Note: If you are using a 2840K#PC or 2840K#RIF, the accuracy of your readings would be 500 times more (0.2 ml vs. 100 ml accuracy). Therefore for a K_{sat} as low as 10^{-7} to 10^{-8} , a 1- to 5-minute sampling interval would be enough.

It is not critical to record reading “sat exactly equal time” intervals but it is important to accurately record the time for each reading. It is possible to start recording several minutes after opening the Valve and when it seems that a constant water head has been well established and the soil around the Borehole is saturated. For each reading (data point) write the current time under column “Time” and write the level of water in the Reservoir under column “Reservoir Water Level”.

Add more water if Reservoir is low. Record the reservoir water level as well as time right before and after refilling. It is recommended not to let the Reservoir run out of water.

Determine the Steady Water Consumption Rate. The measurement ends when the “Water Consumption Rate” does not change over several consecutive readings. For each reading, Water Consumption Rate is calculated using the following formula:

$$R_i = \frac{d_{(i-1)} - d_i}{t}$$

Where R_i is Water consumption Rate of the current reading (ml/min), $D_{(i-1)}$ is Reservoir Water Level of the previous reading (ml), d_i is Reservoir Water Level of the current reading (ml), and t is the time interval between the previous reading and the current reading (min).



If you are using the SimplyDATA Software Suite application, there is no need to manually perform this calculation. If you are recording data manually, use Appendix A. You would need to calculate R_i for each reading until it reaches a steady state (the amount of R_i does not change significantly over several readings).

In the Steady Water Consumption Rate stage (Fig. 21), the steady “Water Consumption Rate” is equivalent to the soil Steady Flow Rate (Q) or Soil-Water Steady Infiltration Rate which is the key parameter to calculate saturated hydraulic conductivity.

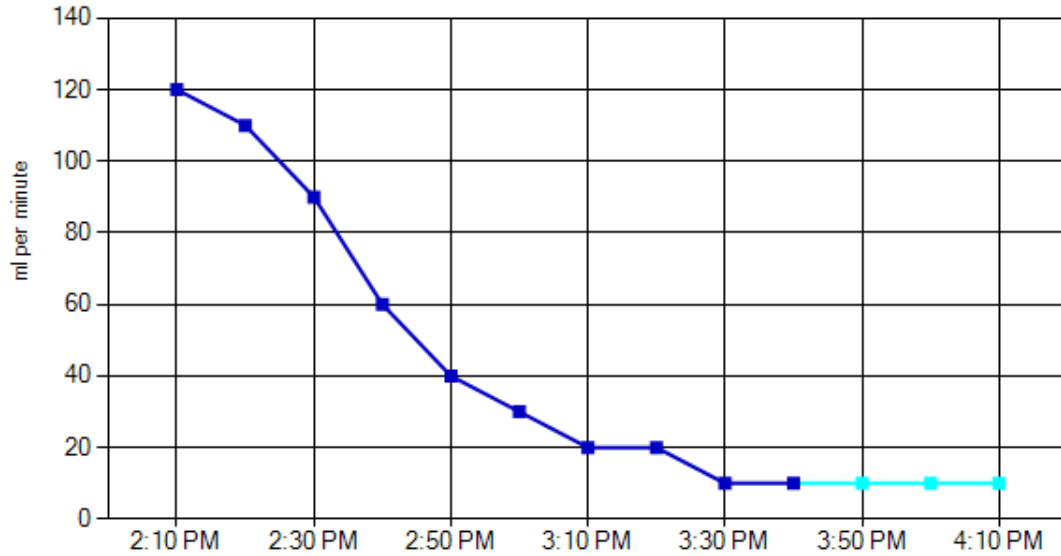

Fig. 21. Water Consumption Rate against time. The cyan points represent steady flow rate (Q).

Operating Model 2840K1PC and Model 2840K2PC

(Automated Readings Using a PC)

Performing measurements are much more accurate and easy using the PC Kits. These kits contain a 2840K1 kit (for Shallow Measurements) or a 2840K2 kit (for Deep Measurements) as well as a Digital Scale (Model 7201W10). See kit components in Fig. 2 and Fig. 3.

The Digital Scale is connected to a personal computer or laptop (not included) using a USB port and records the measurements automatically. The accuracy of measurements for water flow rate is 0.2 gram (one gram is equivalent to one ml (cc or cm³) of volume for pure water). Once the steady flow rate is established in the Borehole, the software calculates K_{sat} automatically and there is no need to continue the measurements (although it is possible). This kit is ideal for automated and accurate measurements in the laboratory and outdoors (when a personal computer is available).

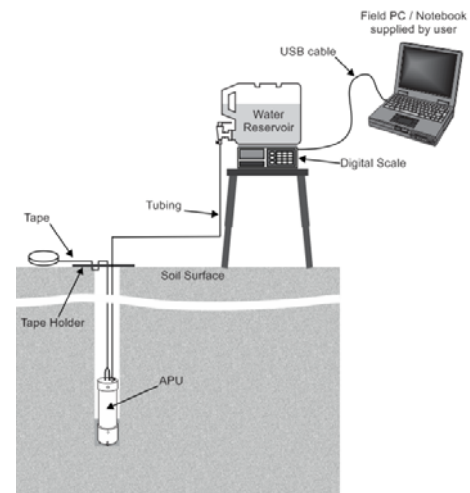

Fig. 22. Schematic of Model 2840K1PC setup and arrangement.

In case a PC is not available, the 2840K1PC and 2840K2PC can still be used as a more accurate version of the Basic Aardvark. The SimplyDATA Scale operates on batteries. Therefore it can be used wherever needed.

The Installation procedure is similar to Model 2840K1. Refer to the section “Operating Model 2840K1 and Model 2840K2” for instructions about assembling and placement of the Aardvark Table; components; assembling and installing the Aardvark Permeameter Module (APM) in a Borehole and assembling the Aardvark Reservoir Unit (RU).

After preparing a Borehole and Installing the APM, follow these steps:

Place Scale and Reservoir on the Table and make sure that they are centered with the Table legs (Fig. 23). Note that the Reservoir is relatively heavy and if it is not centered with Table legs, it may tip over.

Connect the Scale to your PC using the USB cable provided in the kit. Please refer to the USB Digital Scale (Model 7201) operating Instructions for more details and illustrations.

Install the SimplyDATA Software Suite on your computer (if not already installed). Please refer to the SimplyDATA Software Suite (Model 8010SFAGB02) Operating Instructions for more details.

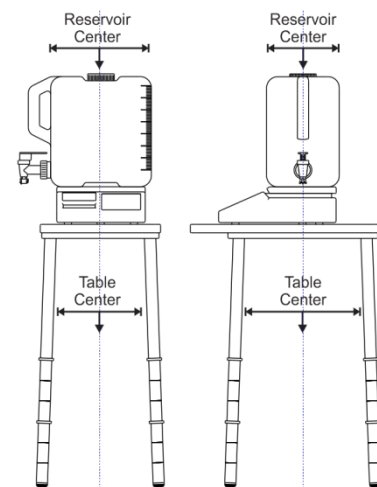
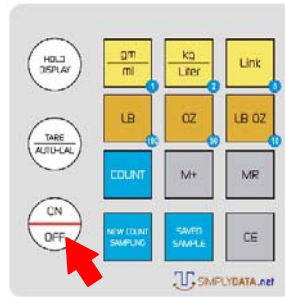
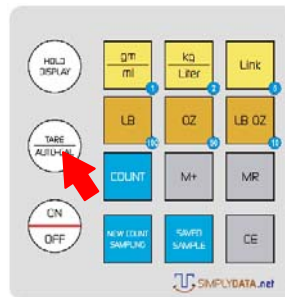

Fig. 23. How to center Scale and Reservoir with Table.

Turn on the Scale.



Tare the Scale if needed. It is not really important for the software to tare the scale. However it ensures more readable data (especially if making readings manually).



Connect the Valve Quick Connection provided in the kit to the end of the Tubing (Fig. 14 a). The other end of the Tubing should be already connected to the RU or APM.

Connect the Valve to the Reservoir and make sure the spigot is closed (Fig. 10).

Fill Reservoir with clean water up to 7 liters (2 gallons) and replace the Cap. Dry the Reservoir exterior if needed. Note that the Scale is an electronic device and for better performance it needs to be kept dry and clean.

Carefully place the Reservoir on the Scale and make sure that both the Reservoir and Scale are level and centered with the four legs of the Table.

Connect the Tubing to the Reservoir Valve and secure the Tubing to the Table using the Tubing Clip provided (see Fig. 3 left, for a suggested Clip position). NOTE: the Tubing should not hang from the Reservoir otherwise moving the tubing would affect the Scale readings. Also try not to shake the Reservoir. It can affect the Scale readings. Wind can have a dramatic effect on Scale performance. Protect the Table setup from wind if necessary. In the case of severe wind, it is recommended to set the table up in a tent.

Remove the Reservoir Cap.

Making a Reading

If you are recording readings manually, please refer to the section “Making a Reading” in the 2840K1 instructions. Please note that the precision of the Scale is relatively high (0.2 ml). In comparison with the increments on the Reservoir, it is 500 times more accurate; therefore you can reduce the reading interval time dramatically. Using a Borehole with standard dimensions (10 cm diameter and about 10 cm water head) and with a one minute reading interval you are able to measure K_{sat} values as small as 10^{-7} to 10^{-8} m/s. In the case that the Scale is connected to a PC, you would be able to make readings automatically. Please refer to the SimplyDATA Software Suite (Model 8010SFAGB02) Operating Instructions for more details.



Operating Model 2840K1RIF and Model 2840K2RIF

(Self-Sufficient Automated Measurements)

This kit is a self-sufficient automatic system. Record It in a Flash (RIF) is designed to eliminate the need for a computer in outdoor automated samplings and where a computer is not available. The kit contains a 2840K1 kit (for Shallow Measurements) or a 2840K2 (for Deep Measurements), a Digital Scale (Model 7201W10) and an RIF (Model 7205). Fig. 3, Fig. 4 and Fig. 5 show the system components.

Record It in a Flash is connected to the Scale and stores the measurements. Once a Steady Flow Rate is established, the RIF automatically calculates K_{sat} and alerts the user to end the experiment (if desired). This feature makes it extremely easy to operate Aardvark Permeameter even by inexperienced users.

Record It in a Flash also supplies power to the Scale. This way there is no need to connect the Scale to a personal computer or power source. The RIF uses 4 C-size alkaline batteries. It is able to operate for hours when no other source of power is available. The RIF also has an AC-DC Wall Adapter for indoor applications.

The Installation procedure is very similar to Models 2840K#PC. Refer to the “Operating Model 2840K1...” section for instructions about assembling and placement of the Aardvark Table; installing the Aardvark Permeameter (just APM or APM plus RU) in a Borehole and setting up the Aardvark Reservoir. See Figure 24 for arrangement of the Reservoir, Scale and RIF on the Table. Level the Scale and Reservoir and center them with the four legs of Aardvark Table (Figure 25). Connect the Scale to the RIF (using the USB cord provided in the Scale Case) and follow the RIF’s instructions (7205 Operating Instructions that comes with RIF) for initializing and operation. For transferring data from the RIF to your PC refer to the Model 8010SFAGB02 (SimplyDATA Software Suite) application manual.

Making a Reading

Using the 2840K#RIF you are able to make readings automatically. Please refer to Record It in a Flash (Model 7206) Operating Instructions for more details.

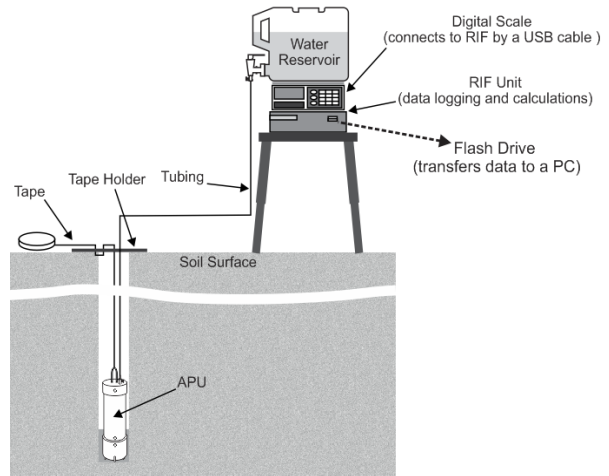

Figure 24. Schematic of Model 2840K1PC arrangement.

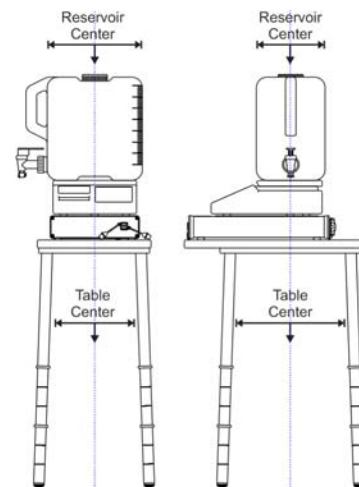

Figure 25. How to center RIF, Scale and Reservoir with Table.

USEFUL HINTS DURING NORMAL USE

Familiarize yourself with the setup, operation, procedure theory, and calculations before going to the field with the Aardvark Permeameter. Doing so will facilitate accurate measurements and interpretation of results.

If you collapse the Borehole, the RU and APM could fall in. The Suspension Line (Tape) is robust and durable; however you should protect it with a rope or cable line. This would be a great help when you are trying to remove the APM from a collapsed borehole.

Wash the APM after each measurement. It will protect it against leaking and guarantee a long and reliable performance.

Always keep an eye on connections. Leaks in connections can dramatically reduce the measurement accuracy. Aardvark connections are robust and reliable; however, putting stress on connections (e.g. hanging the APM from tubing or using lubrication to connect two pieces of tubing) can make them susceptible to leaks especially in deep measurements when the overhead pressure is high.

Never let the Tubing hang directly from the Reservoir Valve. When the Tubing is filled with water, its weight can tip over the Reservoir and if it doesn't, it definitely would have a negative impact on Scale readings. Secure the Tubing in the way that its weight is not on the Reservoir Valve. Also use Tubing Clip to secure Tubing on Table.



TROUBLESHOOTING

Problem

Possible Reason

The Scale "Self-test" procedure takes a long time

The scale is shaking due to wind or other reasons. Protect Scale and the Table setup from wind. The ultimate solution to the wind problem is to set up the Table in a secured tent.

The numbers on Scale jump up and down

This usually happens due to wind. Try to protect the Table setup from wind.

From the beginning of the measurement, Water Consumption Rate does not reduce over time.

It may have two specific reasons.
First: soil is too fast (excessive hydraulic conductivity, for example coarse sand or gravel). In this case Aardvark water supply rate is less than soil infiltration rate and a constant heat cannot be established.
Second: the Floating Valve is not working properly. Remove the APM Cap and check it.

Reservoir body collapses gradually over time

The Reservoir Cap is on. Take the Reservoir Cap off to let water flow freely to the Borehole.



GENERAL CARE AND MAINTENANCE

Disassembling the Aardvark Permeameter Module

You may want to take the APM apart to clean it. Remove the Connecting Pins from the APM and separate it from the Body Tube. The Pins are designed so you can push them in or take them out easily without any tools. However there is a Pin Access Tool in the Support Kit should you need it. To avoid injury, please take special care while working with the Pin Access Tool. Avoid removing a Pin using a screwdriver or other sharp tools.

Cleaning APM

1. Use the Pin Access Tool to remove Pins from the upper part of Body Tube. Detach Head Assembly from Body Tube. There is no need to detach the End Cap from the Body Tube.
2. Soak the components in soapy water for 5 minutes and then rinse with clean water.
3. In order to clean the internal parts of the Head Assembly and Floating Valve, pour soapy water into the Reservoir. Then connect the Reservoir to the Head assembly using the Tubing and open the Valve and let the soapy water run through Head Assembly. Repeat this procedure with clean water allowing it to flow through the Head Assembly for one or two minutes. This will assure a long and reliable performance of the unit.
4. Put Floating Bottle inside Body Tube and make sure that it can move up and down freely.
5. Connect Head Cap to Body using Pins.



USE AND APPLICATION OF PRODUCT OPTIONS

Borehole Preparation Kit

The Aardvark permeameter is designed to be installed in a borehole in a soil profile from 20 cm (7.9") to 15 m (50 ft) depth. Therefore before installing Aardvark Permeameter, you need to dig and prepare a borehole. The equipment needed to dig a borehole depends on the width and depth of the desired hole. Our Model 0237D10L12 contains all the required tools and instructions for augering and cleaning a borehole with 10 cm (4") width (Aardvark recommended width) and up to 4 m (12 ft) depth.

Aardvark Pressure Regulator Unit (RU)

The APM has been designed to perform under a maximum of 5 psi (about 344 kPa or 3.44 m of water column). Therefore for Deeper Measurements ($D \geq 3.44$ m), you need to use an Aardvark Pressure Regulator in-line. The RU reduces the overhead pressure to 344 kPa (5 psi). Simply add the RU in line with the APM so that water goes through the RU before the APM. Note that the vertical distance of the RU and APM must be minimal. An RU Connection Tubing and a Quick Link comes with the RU to connect the RU and APM (Fig. 27).

In Shallow Measurements you do not need the Regulator Unit (RU).

The Aardvark Permeameter can be used anywhere a hole can be augered in soil. Because of the practical improvements incorporated in the operation of the Aardvark Permeameter and the advanced analysis the theory provides, it is ideally suited for applications involving the design and monitoring of:

- Irrigation Systems
- Drainage Systems
- Canals
- Reservoirs
- Sanitary Landfills
- Land Treatment Facilities
- Tailings Areas
- Hazardous Waste Storage Sites
- Septic Tank systems
- Soil and Hydrologic Studies and Surveys



Fig. 26. Model 0237D10L12 Borehole Preparation kit.

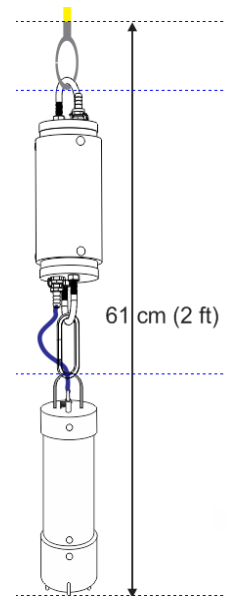

Fig. 27. Regulator Unit in line with APM.

CALCULATIONS AND APPLICATIONS

Using the SimplyDATA Software Suite for manually recorded data

The Aardvark Permeameter kit contains a flash drive with the SimplyDATA Software Suite. The software performs all the necessary calculations required for calculating soil hydraulic conductivity. To use the software you will need a personal computer. Simply enter the raw measurements data and it calculates K_{sat} as well as some other useful parameters and graphs. Please refer to the “SimplyDATA Software Suite Operating Instructions” for more details. If you are using the Model 2840K#PC connected to a computer or Model 2840K#RIF, the software performs all the measurements and calculations automatically. Please refer to the SimplyDATA Software Suite Operating Instructions for more details.

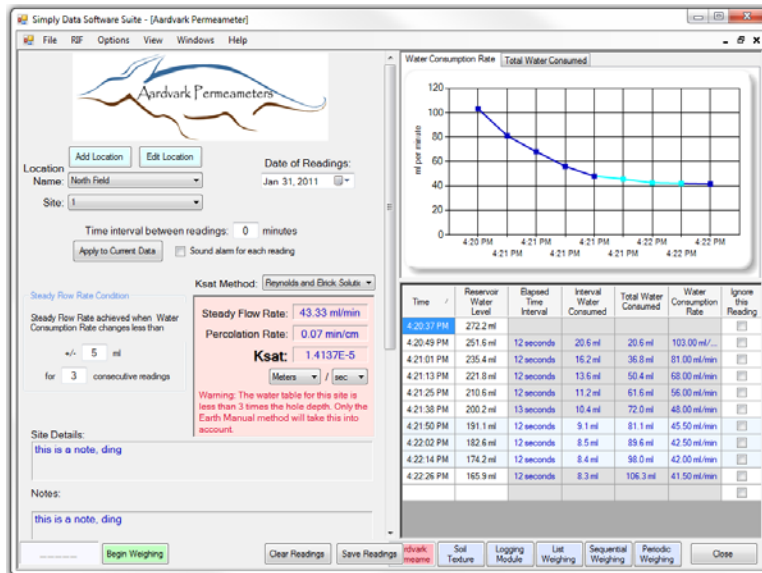

Fig. 28. Permeameter application of the SimplyDATA Software Suite.

Manually Performing the Calculations

These instructions use the method introduced by US Department of Interior (Earth Manual Part2, Third Edition, and P. 1234-5. Denver, Colorado 1990). The SimplyDATA Software Suite is able to calculate K_{sat} using three different methods.

Determining the Steady Flow Rate (Q)

A sample data sheet is presented in Table 1. For determining Steady Flow Rate, follow the below instructions.

Calculate “Elapsed Time Interval” for each reading in minutes. It is the difference of “Time” of the reading with “Time” of the previous reading (see the bold calculations in each cell of table). Therefore for the first row of the table (the first reading), “Elapsed Time Interval” is not calculated.

Calculate “Interval Water Consumed” for each reading in milliliter (ml). It is the amount of water that goes to Borehole during the two consecutive intervals. In other words, it is the difference between “Reservoir Water Level” of a reading and “Reservoir Water Level” of the previous reading (see the bold calculations in each cell). Therefore for the first line of the table (the first reading), “Reservoir Water Level” is not calculated. Note the volume of one gram of water is one ml (cc or cm^3). Therefore generally speaking, for pure water, the three units are equivalent and one can use any of them for the other one.

Calculate “Total Water Consumption” as the total sum of “Water Consumption Rate” (see the bold calculations). Calculating of this column is optional.

Calculate “Water Consumption Rate” for each reading in ml/s. For each line of Table 1, “Water Consumption Rate” can be calculated by dividing “Interval Water Consumed” by “Elapsed Time Interval” (see the bold calculations). Therefore for the first line of the table (the first reading), “Water Consumption Rate” is not calculated.

Determine the Steady Flow Rate (Q). It is established when “Water Consumption Rate” (flow rate) does not change significantly over several consecutive readings. Obviously “Water Consumption Rate” would not be exactly equal between consecutive readings even when a steady flow has been established. Using the Water Consumption Rate graph against time is a useful tool for determining Q. In this graph, the horizontal phase of curve (parallel with time axis) represents the amount of Q. In Table 1, since “Water Consumption Rate” does not change from Reading 10 to Reading 14, we assume that the Steady Flow Rate (Q) is 10 ml/min. Fig. 29 is the graphical presentation of the same data. For converting Q unit from ml/min to gallon/s, it has to be multiplied by 0.000264.

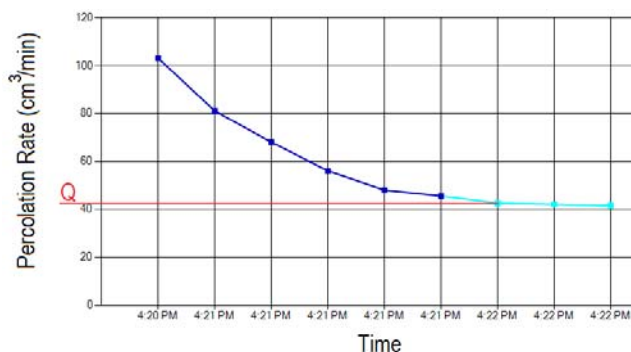

Fig. 29. Soil-water infiltration rate over time and Steady Flow Rate (Q).

Table 1. A sample data sheet. The bold writings are for illustrating the calculations. Columns "Time" and "Water Level in Reservoir" are the readings from Aardvark Permeameter. Other columns have to be calculated.

| Aardvark Permeameter Field Data Sheet | | | | READING AND CALCULATION | | |
|--|---------|--|-----------------------------|---|------------------------------|---------------------------------|
| DATE: | | INVESTIGATOR: | | Q: Steady Flow Rate (ml/min): 10 | | |
| 2r: Borehole Diameter (cm): 10.16 | | h: Water Height in Borehole (cm): 10.1 | | S: Depth of Water Table (cm): 350 | | |
| H: Borehole Depth (cm): 340 | | D: Vertical distance between Reservoir and APM (cm): 400 | | Water Temperature: 20 | | |
| Soil Texture/Structure Category: structured agri. soil | | | | | | |
| Reading Number | Time | Water Level in Reservoir (ml) | Elapsed Time Interval (min) | Interval Water Consumption (ml) | Total Water Consumption (ml) | Water Consumption Rate (ml/min) |
| 1 | 2:00 pm | 7000 | | | | |
| 2 | 2:10 pm | 5800 | 2:10 - 2:00= 10 | 7000 - 5800= 1200 | 1200 | 1200 / 10= 120 |
| 3 | 2:20 pm | 4700 | 2:20 - 2:10= 10 | 5800 - 4700= 1100 | 1200 + 1100= 2300 | 110 / 10= 110 |
| 4 | 2:30 pm | 3800 | 2:30 - 2:20= 10 | 4700 - 3800= 900 | 2300 + 900= 3200 | 900 / 10= 90 |
| 5 | 2:40 pm | 3200 | 2:40 - 2:30= 10 | 3800 - 3200= 600 | 3200 + 600= 3800 | 600 / 10= 60 |
| 6 | 2:50 pm | 2800 | 2:50 - 2:40= 10 | 3200 - 2800= 400 | 3800 + 400= 4200 | 400 / 10= 40 |
| 7 | 3:00 pm | 2500 | 3:00 - 2:50= 10 | 2800 - 2500= 300 | 4200 + 300= 4500 | 300 / 10= 30 |
| 8 | 3:10 pm | 2300 | 3:10 - 3:00= 10 | 2500 - 2300= 200 | 4500 + 200= 4700 | 200 / 10= 20 |
| 9 | 3:20 pm | 2100 | 3:20 - 3:10= 10 | 2300 - 2100= 200 | 4700 + 200= 4900 | 200 / 10= 20 |
| 10 | 3:30 pm | 2000 | 3:30 - 3:20= 10 | 2100 - 2000= 100 | 4900 + 100= 5000 | 100 / 10= 10 |
| 11 | 3:40 pm | 1900 | 3:40 - 3:30= 10 | 2000 - 1900= 100 | 5000 + 100= 5100 | 100 / 10= 10 |
| 12 | 3:50 pm | 1800 | 3:50 - 3:40= 10 | 1900 - 1800= 100 | 5100 + 100= 5200 | 100 / 10= 10 |
| 13 | 4:00 pm | 1700 | 4:00 - 3:50= 10 | 1800 - 1700= 100 | 5200 + 100= 5300 | 100 / 10= 10 |
| 14 | 4:10 pm | 1600 | 4:10 - 4:00= 10 | 1700 - 1600= 100 | 5300 + 100= 5400 | 100 / 10= 10 |
| | | | | | | |
| | | | | | | |
| | | | | | | |
| | | | | | | |
| | | | | | | |
| | | | | | | |
| | | | | | | |



Calculating saturated hydraulic conductivity (K_{sat})

Saturated Hydraulic conductivity can be calculated using several methods. The following calculations are based on USBR 7300-89 procedure (Earth Manual Part2, Third Edition, and P. 1234-5. Denver, Colorado 1990). SimplyData Software Suite is able to perform some other methods (please refer to SimplyData Software Suite Operating Instruction).

Depending on the value of L/h ratio (L is the vertical distance between constant water head (h) and water table / impervious layer; see Fig. 6), K_{sat} can be calculated from different formulas:

Condition I: when L/h is greater than three ($L/h > 3$)

$$K_{sat} = \frac{Q}{2\pi h^2} \left\{ \ln \left[\frac{h}{r} + \sqrt{\left(\frac{h}{r}\right)^2 + 1} \right] - \frac{\sqrt{1 + \left(\frac{h}{r}\right)^2}}{\frac{h}{r}} + \frac{1}{\frac{h}{r}} \right\} \quad \text{Unit: cm/min} \quad \text{Equation [1]}$$

Condition II: when L/h is between one and three ($1 \leq L/h \leq 3$)

$$K_{sat} = \frac{Q}{2\pi h^2} \left[\frac{\ln(h/r)}{\frac{1}{6} + \frac{1}{3} \left(\frac{L}{h}\right)} \right] \quad \text{Unit: cm/min} \quad \text{Equation [2]}$$

Condition III: when L/h is greater than three ($L/h < 1$)

$$K_{sat} = \frac{Q}{2\pi h^2} \left[\frac{\ln(h/r)}{\frac{L}{h} + \frac{1}{2} \left(\frac{L}{h}\right)^2} \right] \quad \text{Unit: cm/min} \quad \text{Equation [3]}$$

Where K_{sat} is saturated hydraulic conductivity (cm/s), Q is steady flow rate (ml/s), h is height of constant water head in Borehole (cm), r is radius of Borehole (cm) and L is the vertical distance between water surface in Borehole and the water table (cm), \ln is the symbol for natural logarithm and π is 3.14. Note: for converting K_{sat} unit from cm/s to inch/s, it has to be multiplied by 0.39.

Parameter L can be easily calculated:

$$L = s - H + h = 350 - 340 + 10.1 = 20.1 \quad \text{Unit: cm} \quad \text{Equation [4]}$$

Where H is borehole depth, h is constant water head height in borehole, s is water table depth and L is the vertical distance between constant water head and water table/impervious layer.

Since the L/h ratio in Table 1 is between 1 and 3, Equation [2] has to be used for calculating K_{sat} :

$$K_{sat} = \frac{10}{2\pi 10.1^2} \left[\frac{\ln(10.1/5.08)}{\frac{1}{6} + \frac{1}{3} \left(\frac{20.1}{10.1}\right)} \right] = 0.0010 \quad \text{Unit: cm/min} \quad \text{Equation [5]}$$

REPLACEMENT PARTS LIST

REPLACEMENT PARTS

| ITEM | PART # | DESCRIPTION |
|---|--------------------|---|
| Aardvark Carrying Case | XCASE-PLBD25X14X7 | |
| Tape Holder | 2840K1-0000-03 | |
| Aardvark Permeameter Module | 2840-1000 | |
| Aardvark Reservoir | 2841V2.0 | |
| Countdown Timer | XLB-TIMER60MMECH | |
| Measuring Tape/ Suspension Line | 2844L50 | 50 feet |
| Connecting Tube | XTPTY-0.250X0.375 | 50 feet |
| Aardvark Pressure Regulator Unit | 2840-2000 | For measurements deeper than 3 m (10 ft) |
| Aardvark Table | XUTABW14XH11 | |
| Aardvark Operating Instructions | 0898-2840 | |
| Aardvark Support Package | 2840K1SUPKG | |
| SEC All Weather Notebook | 0899-006 | |
| Plastic Connection Pin | XFPNY.250AC9 | |
| Tubing Coupler (Barbed Connector) | XPB44T-4BTX4BTTP | ¼" to ¼" |
| Quick Connection Insert | XPBQC-4BTMPCAT | ¼" hose to PMC |
| Pin Access Tool | XTLH-4" TACKPULLER | |
| Hose Clamp | XHWCHC-5/16-13/32 | 5/16" to 13/16" to 13/32" Zinc Plated Steel |
| LED Flash Light | XHWMIS-LEDFLASH | |
| Tubing Clip | XHWCL-#4CLIP | |
| SILICON Grease | MFJ012PK | ¼ Once |
| SEC Writing Pen | 0899-009 | |
| SEC Tape Measure | | 6 ft. |
| Flash Drive Loaded with SimplyData Software Suite | 8010SFAGB02 | |
| Digital Scale Package | 7201W10PKG | Complete package in the case |
| Digital Scale | 7201W10-001 | The unit itself (10 Kg, 0.2g accuracy) |
| Scale Carrying Case | 7202 | |
| USB Cable | XCMPC-UFUML05 | For Digital Scale |
| Scale Power Supply | 7201PWR | |
| Record It in a Flash (RIF) | 7205RIF | The unit itself |
| RIF Carrying Case | 7206 | |
| 'C' Size Alkaline Battery | XBATAKR-C1.5V | 1.5 V |
| RIF Power Supply | 7205PWR | |

ACCESSORIES AND USEFUL ITEMS FOR THIS UNIT

| ITEM | PART # | DESCRIPTION |
|--------------------------|---------------|--|
| Borehole Preparation Kit | 0237D10L10 | |
| Loam Soils Auger | 0234LOMBD10 | 10 cm Loam Soil Auger, Dutch Type, bayonet connection |
| Auger Extension Rod | 0234SHDLBXL30 | 30 cm Auger Extension Rod, bayonet connection |
| Well Prep Brush | 0234WPBBD10 | 10 cm Well Prep Brush, bayonet connection |
| Carrying bag | XBAG-0237 | Auger Kit Carrying Bag |
| Sizing Auger | 0234HBPBD10 | Sizing Auger, 10cm hole, bottom prep, bayonet connection |
| Auger Handle | 0234SHDLB | Auger Handle with detachable grip, 60 cm, bayonet connection |



Appendix A

Aardvark Permeameter Sample Datasheet

| Aardvark Permeameter Field Data Sheet | | | | READING AND CALCULATION | | |
|---------------------------------------|------|--|-----------------------------|--------------------------------------|------------------------------|---------------------------------|
| DATE: | | INVESTIGATOR: | | Q: Steady Flow Rate (ml/min): | | |
| 2r: Borehole Diameter (cm): | | h: Water Height in Borehole (cm): | | S: Depth of Water Table (cm): | | |
| H: Borehole Depth (cm): | | D: Vertical distance between Reservoir and APM (cm): | | Water Temperature: | | |
| Soil Texture/Structure Category: | | | | | | |
| Reading Number | Time | Water Level in Reservoir (ml) | Elapsed Time Interval (min) | Interval Water Consumption (ml) | Total Water Consumption (ml) | Water Consumption Rate (ml/min) |
| | | | | | | |
| | | | | | | |
| | | | | | | |
| | | | | | | |
| | | | | | | |
| | | | | | | |
| | | | | | | |
| | | | | | | |
| | | | | | | |
| | | | | | | |
| | | | | | | |
| | | | | | | |
| | | | | | | |
| | | | | | | |
| | | | | | | |
| | | | | | | |
| | | | | | | |
| | | | | | | |
| | | | | | | |
| | | | | | | |
| | | | | | | |
| | | | | | | |
| | | | | | | |
| | | | | | | |
| | | | | | | |
| | | | | | | |
| | | | | | | |
| | | | | | | |
| | | | | | | |
| | | | | | | |
| | | | | | | |
| | | | | | | |



**With dealers throughout the world,
you have convenience of purchase and assurance
for after sales service.**

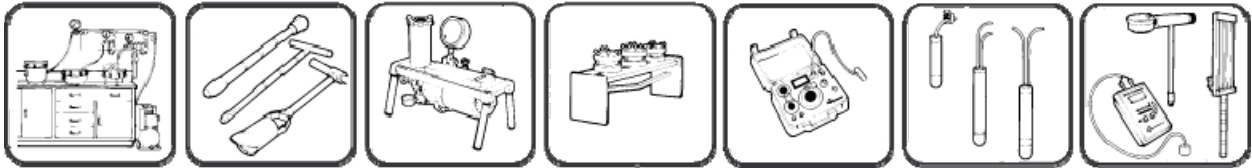

Standard Operating Procedure B-3: Low-Flow Groundwater Sampling for Chemical Analysis

Standard Operating Procedure B-3: Low-Flow Groundwater Sampling for Chemical Analysis

1 Purpose and Scope

This standard operating procedure (SOP) describes the procedures to be followed by a Field Geologist/Engineer while collecting groundwater samples using low-flow purging and sampling procedures. The low-flow methodology may alternatively be referred to by names such as “micropurging”, “low-stress purging”, low-impact purging, or “minimal drawdown purging.” This SOP should be used primarily for collection of groundwater samples from permanent wells that have been designed, constructed, and developed for the purpose of monitoring groundwater. The groundwater samples that are collected using this SOP are acceptable for the analysis of environmental contaminants including, but not limited to: volatile organic compounds (VOCs), semi-volatile organic compounds (SVOCs), pesticides and herbicides, polychlorinated biphenyls (PCBs), petroleum hydrocarbons, metals, and other inorganic compounds.

The procedures presented herein are intended to be of general use and may be supplemented by a Work Plan, Sampling and Analysis Plan, Quality Assurance Project Plan, and/or a Health and Safety Plan. Some of these procedures may not be required depending on the specific scope of work being conducted. As the work progresses, and if warranted, appropriate revisions may be made by the Project Manager. Procedures in this protocol may be superseded by applicable regulatory requirements.

2 General Requirements

All personnel performing on-site operations with the potential for exposure to hazardous substances or health hazards are required to be 40-hour trained in accordance with Code of Federal Regulations (CFR) 1910.120 and will meet the personnel training requirements in accordance with 29 CFR 1910.120(e).

The laboratory must be certified by the appropriate regulating agency for the analyses to be performed. If drilling is required as part of the scope of work, permits will be acquired from the appropriate agency, and an underground utility check will be performed before drilling begins. An underground utility check will, at a minimum, consist of contracting with a local utility alert service, if available. Under certain circumstances, including at sites with deeply buried, unknown, or multiple underground utilities, as well as at high risk sites such as oil refineries and heavy industrial facilities, manual utility clearance using hand auger or air knife methods should also be performed.

The activities described in this SOP require the implementation of a site-specific Health and Safety Plan to inform personnel of the hazards associated with this work and to describe the methods that will be employed to mitigate those hazards. The Health and Safety Plan must be prepared and approved by the Project Manager and the local Health and Safety Coordinator prior to initiating field work. A Health and Safety Meeting must be held at the start of each day to reassess any potential hazards associated with that day’s field work.

3 Methods

This SOP has been prepared in accordance with the United States Environmental Protection Agency (USEPA) Standard Operating Procedure for Low-Stress (Low Flow)/Minimal Drawdown

Ground-Water Sample Collection, dated 2002. This guidance document is included as Attachment 3 of the Ground-Water Sampling Guidelines for Superfund and RCRA Project Managers, which may be found via the following internet link:

http://www.epa.gov/swertio1/tsp/download/gw_sampling_guide.pdf

This methodology described herein is also consistent with the California Environmental Agency's (Cal-EPA), Representative Sampling of Groundwater for Hazardous Substances, Guidance Manual for Ground Water Investigations, dated June 2005. This document may be found via the following internet link:

http://www.dtsc.ca.gov/SiteCleanup/upload/SMP_Representative_Sampling_GroundWater.pdf

Unlike traditional purging methods, low-flow purging and sampling does not require the removal of an arbitrary volume of water from a well prior to sampling. Instead, low-flow purging and sampling relies on careful monitoring of water quality indicator parameters to determine when a representative groundwater sample can be collected. The low-flow methodology minimizes the effects on groundwater chemistry caused by the purging process by minimizing drawdown, reducing the amount of water removed from the well, and reducing the amount of turbidity in groundwater samples.

4 Equipment and Materials

A non-exhaustive summary of common supplies and equipment is presented below:

- Health and Safety Plan
- Site information (maps, contact numbers, previous field logs, etc.)
- Electronic water level indicator (Solinst or similar)
- Photoionization Detector (PID) or Flame ionization detector (FID) if VOCs are suspected
- Adjustable-rate sampling pump capable of rates <0.5 liters per minute (bladder pump preferred, e.g., QED Sample Pro)
- Bladders for sample pump
- Sample tubing (Teflon® or Teflon®-lined tubing preferred for sampling organic compounds)
- Multi-parameter meter (e.g. YSI 556 Multi-Parameter Meter) with flow through cell capable of measuring (at a minimum) temperature, pH, specific electrical conductance (SEC), dissolved oxygen (DO), and oxidation-reduction potential (ORP)
- Turbidity meter
- In-line filters (if required, e.g. for dissolved metals)
- Certified-clean sample containers and preservation supplies, sample labels, Ziploc™ bags

- Cooler with ice
- Decontamination supplies (e.g. phosphate-free detergent, distilled water)
- Tool kit with appropriate tools (socket wrench set, pry bar, Dolphin locks/keys)
- Drum(s) to collect purged water and decontamination water
- Drum labels
- Personal Protective Equipment (PPE), typically PPE will consist of:
 - Long-sleeved shirt and long pants
 - Steel-toed boots
 - Hardhat
 - Nitrile gloves
 - Safety glasses with side shields
 - Other as required by Health and Safety Plan
- Field Forms (If the project requires it, a project-specific Field Logbook may substitute for any of the following with the exception of the Chain of Custody)
 - *Field Investigation Daily Log*
 - *Water Level Measurement Log*
 - *Low-Flow Purging and Sampling Log*
 - *Equipment Calibration Log*
 - *Chain-of-Custody*

5 Procedures

The following sections discuss the procedures to follow during low-flow purging and sampling monitoring wells with dedicated or non-dedicated equipment (e.g., bladder pumps with adjustable rate controls). Where applicable and when possible, the purging and sampling techniques should remain consistent from one sampling event to the next.

5.1 Pre-Sampling Activities

1. Sampling should begin at the monitoring well with the least contamination, generally up-gradient or farthest from the site or suspected source. Then proceeding systematically to the monitoring wells with the higher expected groundwater concentrations.
2. All measuring devices and monitoring equipment should be calibrated according to manufacturer's recommendations. Water quality meters must be calibrated daily before use. Equipment calibration details should be recorded in the *Equipment Calibration Log*.
3. Unlock well and/or remove well cap. Record any damage or evidence of pressure (positive or negative) in the well in the *Water Level Measurement Log*. Monitor the headspace at the

top of the well for VOCs with a PID or FID and record findings. If VOCs are present, monitor worker breathing zones during purging and sampling in accordance with the site Health and Safety Plan.

4. Prior to sampling, the depth-to-water in all wells must be measured to obtain the current static water level. Water levels should be measured to the nearest 0.01 feet relative to a reference measuring point on the Top of Casing (TOC) which must be surveyed relative to ground elevation. If there is no marked reference point on the TOC, measure from the North side of the casing. Record depth to groundwater information in the *Water Level Measurement Log*. The same water level measuring device should be used for all wells, if possible, and must be decontaminated between each well.
5. Use existing site information for total depth (TD) of monitoring well and use the information from depth to water to calculate the volume of water in the monitoring well. The TD of wells to be sampled should not be tagged prior to sampling to avoid disturbing sediments at the bottom of the well. If possible, have this information prior to the day of sampling. The TD of wells should be verified after sampling. Record TD and water volume information in the *Low-Flow Purging and Sampling Log*.

5.2 Purging and Sampling

1. If using non-dedicated equipment, place the pump and support equipment at the well head and slowly lower the pump and tubing down into the monitoring well until the location of the pump intake is set at a predetermined location within the screen interval. Where possible, pre-measured tubing should be used to place the pump intake at the same depth as previous sampling events, or at a depth where there is known contamination within the screen interval. If there is no previous information for the well, the pump intake should be placed at the middle (or slightly above the middle) of the screen interval. Record the pump depth in the *Low-Flow Purging and Sampling Log*.
2. Measure depth to water to the nearest 0.01 feet relative to the reference measuring point on the TOC with an electronic water level indicator. Record depth to groundwater information in the *Low-Flow Purging and Sampling Log*. Leave water level indicator in the well.
3. Connect the discharge line from the pump to a flow-through cell that at a minimum measures temperature, pH, SEC, DO, and ORP. Turbidity measurements can be made using a separate turbidity meter. The discharge line from the flow-through cell must be directed to a container to hold purge water collected during purging and sampling of the well.
4. Start pumping the well at a flow rate of between 0.1 and 0.5 liters per minute (L/min) and slowly increase the flow rate. (For new wells or wells with no purging history, start at the lower end of that range.) Check the water level. Maintain a steady flow rate while maintaining a drawdown of less than 0.3 feet. (Zero drawdown is optimal, but infrequently achievable). If drawdown is greater than 0.3 feet, lower the flow rate; 0.3 feet is a goal to help guide with the flow rate adjustment. This goal will be difficult to achieve in some wells due to low hydraulic conductivities and limitations to the lowest flow rate a pump can produce while maintaining steady flow. This goal may be adjusted based on site-specific conditions and personal experience. See the Special Advisory at the end of these

procedures.

5. Measure the discharge rate of the pump with a graduated cylinder and a stopwatch.

Also, measure the water level and record both flow rate and water level on the *Low-Flow Purging and Sampling Log*. Continue purging, monitor and record water level and pump rate every 3 to 5 minutes. Purging rates should be kept at minimal flow to ensure

minimal drawdown in the monitoring well.

6. A minimum of one tubing volume (including the volume of the water in the pump and flow cell) must be purged prior to recording the water quality indicator parameters. After this has been accomplished, monitor and record the water quality indicator parameters every three to five minutes in the *Low-Flow Purging and Sampling Log*. Stable readings of temperature, pH, SEC, DO, turbidity and ORP indicate when a representative sample can be collected. The stabilization criterion is based on three successive readings of the water quality indicator parameters as shown in Table 1. ORP may not always be an appropriate stabilization parameter and will depend on site-specific conditions. However, readings should be recorded because of its value for double-checking oxidizing conditions. The stabilization criterion is based on three successive readings of the water quality indicator parameters as shown in Table 1.

| TABLE 1: Stabilization Criteria for Water Quality Indicator Parameters | |
|---|---|
| Parameter | Stabilization Criteria |
| Temperature | ± 3% of reading (minimum of ±0.2° C) |
| pH | ± 0.1 pH units |
| Specific Electrical Conductance (SEC) | ± 3% S/cm |
| Dissolved Oxygen (DO) | ± 0.3 milligrams per liter |
| Turbidity | ± 10% NTUs (when turbidity is greater than 10 NTUs) |
| Oxidation-Reduction Potential (ORP) | ± 10 millivolts |

7. Maintain the same pumping rate or reduce slightly for sampling as necessary in order to minimize disturbance of the water column. Sampling should be collected directly from the discharge port of the pump tubing prior to passing through the flow-through cell. Disconnect the pump's tubing from the flow-through cell so that the samples are collected from the pump's discharge tubing. For samples collected for dissolved gases or VOC analyses, the pump tubing needs to be completely full of ground water to prevent the ground water from being aerated as it flows through the tubing. Generally, the sequence of the samples is immaterial unless filtered (dissolved) samples are collected. Filtered samples must be collected last (see below). All sample containers should be filled with minimal turbulence by allowing the ground water to flow from the tubing gently down the inside of the container.

When filling VOC samples using volatile organic analysis (VOA) vials, a meniscus must be formed over the mouth of the VOA vial to eliminate the formation of air bubbles and head space prior to capping. Effervescence and colorimetric reactions should be recorded in the *Low-Flow Purging and Sampling Log*.

8. If a filtered (dissolved) metal sample is to be collected, then an inline filter is fitted at the end of the discharge tubing and the sample is collected after the filter. The inline filter must first be flushed in accordance with manufacturer's recommendations and if there are no recommendations for flushing, a minimum of 0.5 to 1.0 liter of groundwater from the monitoring well must pass through the filter prior to sampling. (Note: Groundwater filter cartridges are dedicated sampling equipment. A new cartridge should be used at each sampling location. Do not attempt to clean filter cartridges. If the filter becomes clogged or groundwater flow is too slowed, remove and replace with a new filter cartridge.)
9. For non-dedicated systems, remove the pump from the monitoring well. Decontaminate the pump and dispose of the tubing. For dedicated systems, disconnect the tubing that extends from the plate at the wellhead (or cap) and discard after use.
10. Close and lock the well.

Special Advisory: If a stabilized drawdown in the well can't be maintained at 0.3 feet and the water level is approaching the top of the screened interval, reduce the flow rate or turn the pump off (for 15 minutes) and allow for recovery. It should be noted whether or not the pump has a check valve. A check valve is required if the pump is to be shut off during purging. Under no circumstances should the well be pumped dry. Begin pumping at a lower flow rate, if the water draws down to the top of the screened interval again, turn pump off and allow for recovery. If two tubing volumes (including the volume of water in the pump and flow cell) have been removed during purging, then sampling can proceed next time the pump is turned on. This information should be noted in the *Low-Flow Purging and Sampling Log*. This behavior may necessitate an alternative purging and sampling procedure for subsequent sampling events.

5.3 Equipment Decontamination

The electronic water level indicator and the water quality meters will be decontaminated by the following procedures:

1. The water level indicator will be hand washed with phosphate-free detergent and a scrubber, then thoroughly rinsed with distilled water, or steam-cleaned.
2. Water quality meter sensors and flow-through cell will be rinsed with distilled water between sampling locations. No other decontamination procedures are necessary or recommended for these meters since they are sensitive instruments. After the sampling event, the flow-through cell and sensors must be cleaned and maintained per the manufacturer's requirements.

Upon completion of the groundwater sample collection the sampling pump must be decontaminated between monitoring wells. The pump and discharge line including

support cable and electrical wires which were in contact with the groundwater in the well casing must be decontaminated by the following procedure:

1. The outside of the pump, tubing, support cable and electrical wires must be pressure-sprayed with soapy water, tap water and distilled water. Spray outside of tubing and pump until water is flowing off of tubing with each rinse. Use bristle brush to help remove visible dirt and contaminants.
2. Place the sampling pump in a bucket or in a short cylinder or well casing (4-inch diameter) with one end capped. The pump placed in this device must be completely submerged in the water. A small amount of phosphate-free detergent must be added with the potable (tap) water.
3. Remove the pump from the bucket or 4-inch casing and scrub the outside of the pump housing and cable.
4. Place pump and discharge line back in the container, start pump and re-circulate soapy water for approximately 2 minutes.
5. Re-direct discharge line to a 55-gallon drum. Continue to add 5 gallons of potable (tap) water.
6. Turn pump off and place pump into a second bucket of potable (tap) water. Continue to add 5 gallons of tap water.
7. Turn off and place pump into a third bucket which contains distilled/deionized water, continue to add 3 to 5 gallons of water.
8. If hydrophobic contaminants are present (such as separate phase (i.e. LNAPL or DNAPL, high levels of PCBs, etc.) an additional decontamination step, or steps, may be required.
9. Decontamination water will be collected and stored on-site for future disposal by the client unless other arrangements have been made.

6 Quality Control Samples

All field Quality Control (QC) samples must be prepared the same as primary samples with regard to sample volume, containers, and preservation. The sample handling and chain-of-custody procedures for the QC samples will be identical to the primary samples. The following are QC samples that may be collected during groundwater sampling:

- A field duplicate is an independent sample collected as close as possible to the same time that the primary sample is collected and from the same source. Field duplicates are used to document sample precision. Field duplicates will be labeled and packaged in the same manner as primary samples so that the laboratory cannot distinguish between the primary sample and the duplicate sample. Field duplicates are analyzed for the same suite of parameters as the primary samples. The frequency of analysis of field duplicates is generally one for every 20 primary samples, but may vary depending on project requirements.
- Equipment blanks are obtained by running distilled or deionized water over or through the

sample collection equipment after it has been decontaminated, and capturing the water in the appropriate sample containers for analysis. Equipment blanks are analyzed for the same suite of parameters as the primary samples. The frequency of analysis of equipment blanks is generally one for every day that non-dedicated sampling equipment is used, but may vary depending on project requirements.

- Field blanks are used to assess the presence of contaminants arising from field sampling procedures. Field blank samples are obtained by filling a clean sampling container with reagent-grade deionized water. Field blanks are analyzed for the same suite of parameters as the primary samples. Field blanks may or may not be incorporated into a groundwater sampling plan depending on project requirements.
- Trip blanks are sample containers that are used to evaluate sample cross-contamination of VOCs during shipment. For groundwater sampling, trip blanks consist of hydrochloric acid-preserved, analyte-free, deionized water prepared by the laboratory in VOA vials that will be carried to the field, stored with the samples, and returned to the laboratory for VOC analysis. Generally, one trip blank is required to accompany each sample shipping container or cooler that contains samples for VOC analysis; however, this may vary depending on project requirements.

7 Sample Handling and Custody

Samples will be collected, handled, and stored in such a manner that they are representative of their original condition and chemical composition. Identification of samples and maintenance of custody are important elements that must also be utilized to ensure samples characterize site conditions. All samples will be properly identified and maintained under chain-of-custody protocol to protect sample integrity. The following sections discuss the sample handling and custody requirements.

7.1 Sample Identification

To maintain consistency, a sample identification convention including unique identifiers for all groundwater and QC samples must be developed and followed throughout the project. The sample identifiers will be entered onto the sample labels, field forms, chain-of-custody forms, and other records documenting sampling activities.

7.2 Sample Labels

A sample label will be affixed to all sample containers sent to the analytical laboratory. Field personnel will complete an identification label for each sample with the following information written in waterproof, permanent ink:

- Client and project number;
- Sample location and depth, if relevant;
- Unique sample identifier;
- Date and time sample collected;
- Filtering performed, if any;
- Preservative used, if any;

- Name or initials of sampler; and
- Analyses or analysis code requested.

The use of pre-printed sample labels is preferred in order to reduce sample misidentification problems due to transcription errors. Sample labels must be completed and affixed to the sample container in the field at the time of sample collection.

If errors are made on a sample label, corrections will be made by drawing a single line through the error and recording the correct information. Corrections will be dated and initialed.

7.3 Containers, Preservation, and Hold Time

Each lot of preservative and sampling containers will be certified as contaminant-free by the supplier. All preserved samples will be clearly identified on the sample label and *Chain-of-Custody* form. If samples requiring preservation are not preserved, field records will clearly specify the reason for the discrepancy.

Chemical activity continues in the sample until it is either analyzed or preserved. Once the sample has been preserved, the sample may be held for a period of time before analysis. The time from the collection of the sample to the analysis is defined as the holding time. The holding time varies depending on the media being sampled and the analyses being performed. The collection, preservation, and analysis of samples must be conducted to avoid exceeding relevant holding times.

7.4 Sample Handling and Transport

Proper sample handling techniques are used to ensure the integrity and security of the samples. Samples for field measured parameters will be analyzed immediately in the field and recorded in the appropriate field forms. Samples for laboratory analysis will be transferred immediately to appropriate laboratory supplied containers in accordance with the following sample handling protocols:

- Don clean gloves before touching any sample containers, and take care to avoid direct contact with the sample;
- Samples will be quickly observed for color, appearance, and composition and recorded as necessary;
- The sample container will be labeled before or immediately after sampling;
- Sample containers and liners will be capped with Teflon™-lined caps before being placed in Ziploc™-type plastic bags. The samples will be placed in an ice chest kept at 4 °C for transport to the laboratory;
- All sample lids will stay with the original containers, and will not be mixed;
- Sample bottles will be wrapped in bubble wrap as necessary to minimize the potential for breakage during shipment; and
- The *Chain-of-Custody* form will be placed in a separate plastic bag and taped to the cooler

lid or placed inside the cooler. A custody seal will be affixed to the cooler if the samples are to be shipped by commercial carrier. For shipped samples, U.S. Department of Transportation shipping requirements will be followed and the sample shipping receipt will be retained in the project files as part of the permanent Chain-of-Custody document.

7.5 Sample Chain-of-Custody

Sample chain-of-custody procedures will be used to maintain and document sample integrity during collection, transportation, storage, and analysis. A sample is considered to be under the control of, and in the custody of, the responsible person if the samples are in their physical possession, locked or sealed in a tamper-proof container, or stored in a secure area.

The *Chain-of-Custody* form provides an accurate written record that traces the possession of individual samples from the time of collection in the field until they are accepted at the analytical laboratory. The *Chain-of-Custody* form also documents the samples collected and the analyses requested. The sampler will record the following information on the *Chain-of-Custody* forms:

- Client and project number;
- Name or initials and signature of sampler;
- Name of destination analytical laboratory;
- Name and phone number of Project Leader in case of questions;
- Unique sample identifier for each sample;
- Date and time of collection for each sample;
- Number and type of containers included for each sample;
- Analysis or analyses requested for each sample;
- Preservatives used, if any, for each sample;
- Sample matrix for each sample;
- Any filtering performed, if applicable, for each sample;
- Signatures of all persons having custody of the samples;
- Dates and times of transfers of custody;
- Shipping company identification number, if applicable; and
- Any other pertinent notes, comments, or remarks.

Blank spaces on the *Chain-of-Custody* will be crossed out and initialed by the field sampler between the last sample listed and the signatures at the bottom of the sheet.

The field sampler will sign the *Chain-of-Custody* and will record the time and date at the time of transfer to the laboratory or an intermediate person. A set of signatures is required for each relinquished/received transfer, including internal transfer. The original imprint of the *Chain-of-*

Custody will accompany the sample containers and a duplicate copy will be kept in the project file.

If the samples are to be shipped to the laboratory, the original *Chain-of-Custody* relinquishing the samples will be sealed inside a plastic bag within the ice chest, and the chest will be sealed with custody tape that has been signed and dated by the last person listed on the *Chain-of-Custody*. U.S. Department of Transportation shipping requirements will be followed and the sample shipping receipt will be retained in the project files as part of the permanent *Chain-of-Custody* document. The shipping company (e.g., Federal Express, UPS) will not sign the *Chain-of-Custody* forms as a receiver; instead the laboratory will sign as a receiver when the samples are received.

8 Field Documentation

Information collected during groundwater sampling may be recorded on individual field forms. If the project requires it, a project-specific Field Logbook may replace any of the individual field forms with the exception of the *Chain-of-Custody* form. Following review by the Project Manager, the original field records will be kept in the project file. The following forms may be used to document the field activities:

- *Field Investigation Daily Log*
- *Water Level Measurement Log*
- *Low-Flow Purging and Sampling Log*
- *Equipment Calibration Log*
- *Chain-of-Custody*

The *Field Investigation Daily Log* will be completed for each day of fieldwork containing (at a minimum) the times and descriptions of the work performed, the activities of the drillers and any other subcontractors or visitors on-site, arrival and departure times for all involved, and any other pertinent information. For larger projects, or when otherwise deemed appropriate by the Project Manager, this information may alternatively be recorded in a Field Logbook. In these cases, a separate Field Logbook must be used for each project or site.

The *Water Level Measurement Log* will be used to record water level measurements for all wells prior to commencement of groundwater sampling. The type, serial number, and calibration date for the water level measuring device will be included on this form. Additionally, this form will be used to record general observations of the conditions of the wells, wellheads, well boxes, and/or monuments.

The *Low-Flow Purging and Sampling Log* will be used to record the details of purging and sampling information for each well including the depth of the pump, purge rates, and volume purged from each well. This form will also be used to record all of the measurements of drawdown and water quality indicator parameters used for evaluating stabilization.

The *Equipment Calibration Log* will be used to document the calibration and status of any measuring instruments used in the field, e.g., PID/FID, water level measuring device, water quality meters, etc. The frequency and method of calibration will depend on the instrument. Any instruments used will be used in accordance with the factory-provided operating and/or service manuals.

Locations and unique identification of water samples collected from the monitoring wells will be recorded on the *Field Investigation Daily Log*, *Low-Flow Purging and Sampling Log*, a site map, and/or other appropriate forms.

Samples names, date/times, analyses to be performed, and other pertinent information will be recorded on the *Chain-of-Custody* form (discussed in Section 7.5) as a means of identifying and tracking the samples.

Standard Operating Procedure B-4: Monitoring Well Installation and Development

Standard Operating Procedure B-4: Monitoring Well Installation and Development

This standard operating procedure (SOP) is applicable to the installation and development of wells for groundwater monitoring or remediation purposes. This SOP is generic in nature and may be modified in whole or part depending on constraints presented by site conditions and equipment limitations. Modifications of methodologies will be documented in the appropriate field logbook and discussed in reports summarizing field activities. The procedures herein are consistent with Title 35 Section 620E.505(a)(5)(F) of the Illinois Rules.

Well Installation

Prior to invasive activities, a subsurface utility check will be conducted. Wells will generally be constructed using 5- to 20-foot-long screen and sufficient riser to complete the well to, or slightly above, ground surface. The length of the well screen will be selected based on the planned use of each well and the observed lithology. Wells will be constructed using schedule 40 polyvinyl chloride (PVC) casing and 0.010 slot schedule 40 PVC well screen with a threaded bottom cap. Wells will generally be completed with a protective steel cover equipped with a lock to protect the well against damage and unauthorized entry.

Filter Material

Filter material will be well-graded, clean sand (generally less than 2-percent by weight passing a No. 200 sieve and less than 5 percent by weight of calcareous material).

Setting Wells

Upon completion of borehole drilling, the boring will be sounded to determine the total depth, and the PVC well materials will be assembled and lowered into the boring. PVC well materials will be measured to the nearest 0.1 foot and will be assembled such that the screened interval is positioned opposite the target formation. No PVC cement or other solvents will be used. Once the well has been positioned at the desired depth, filter sand will be slowly added to the borehole to fill the annular space to a depth approximately 1 to 2 feet above the top of the well screen. During sand placement, the driller will continually measure the depth to the sand using a weighted tape measure or other device to verify that the sand does not bridge between the auger and the well screen. Two feet of bentonite chips will be added on top of the filter sand and subsequently hydrated using clean, municipal water to form a transition seal. After the bentonite has hydrated for at least 30 minutes, the depth to the top of the bentonite will be measured and recorded. A neat cement/bentonite grout will be added from the top of the bentonite; a tremie pipe will be utilized to ensure that the grout is added from the bottom, upwards. The grout will be permitted to cure for 48 hours prior to well development.

Well Completion

All monitoring wells and monitoring points will be completed with a protective steel cover equipped with a lock to protect the well against damage and unauthorized entry. Wells will typically be completed above grade unless they are located within parking/driving areas, or are piped to a remediation system. Wells completed aboveground will be capped with a push-on well cap and completed with a steel stick-up casing. Wells completed below ground surface will

be capped with an expandable locking well cap and completed with a flush mounted traffic rated steel cover set into a 2 foot by 2 foot concrete pad. All wells will be labeled with a permanent marker that includes the well ID.

Development and Surveying

New wells will be developed after the grout has cured for a minimum of 48 hours. Wells will be developed by surging, bailing, and pumping to reduce or remove drilling-induced formation smear from the borehole walls, to remove sediment that may have accumulated during well installation, consolidate the filter pack, and to enhance the hydraulic connection between the formation target zone and the well. In most cases, a bailer or pump will be used to remove sediment and turbid water from the bottom of the well. A surge block will then be lowered up and down within the screened interval to flush the filter pack of fine sediment and remove smear from borehole walls. Following surging, the well will be bailed or pumped again to remove sediment and turbid water. Water will be removed from the well at a rate greater than the anticipated future pumping rate and water quality parameters including pH, turbidity, specific conductance and temperature will be recorded. Drawdown will also be recorded with an interface probe or water level meter. The development will proceed until sediment is removed sufficiently to achieve a turbidity measurement of 5 NTU (or less). The well installation report will specify if the target turbidity cannot be achieved.

Following well installation and completion, each well will be surveyed by a licensed surveyor to determine the location of the well and to establish the elevation at the top of casing and ground surface with reference to the site datum. Survey data will be incorporated into the database and onto the site base map.

Decontamination of Drilling Equipment

All drilling and well development equipment will be cleaned prior to use, and between wells. Drilling equipment will be steam cleaned, rinsed with potable water, and air dried. If equipment is not immediately put back to use, equipment will be covered with clean plastic to protect the materials from contact with dust or other contaminants. Pumps or other non-dedicated field equipment that comes into contact with impacted media will be cleaned using a non-phosphate detergent followed by a tap water rinse and a final, deionized water rinse. Decontamination water will be collected for appropriate, subsequent off-site disposal. Spent PPE or other disposable materials (e.g., tubing) will be placed into a drum for subsequent disposal.

Documentation

Well installation and construction activities will be recorded in the field notebook. A well construction diagram will be completed for each well, reviewed by appropriate personnel for completeness and accuracy, and filed electronically in the project file. The CQA Officer will complete and submit an IEPA Well Completion form for each well.

References

Illinois Rules, Title 35 Section 620E.505(a)(5)(F).

Standard Operating Procedure B-5: Photoionization Detector (PID) Screening

Standard Operating Procedure B-5: Photoionization Detector (PID) Screening

This standard operating procedure (SOP) is applicable to the use of a photoionization detector/flame ionization detector (PID/FID) instrument during soil sampling activities. The methodology is generic in nature and may be modified in whole or part to meet the handling and analytical requirements of the contaminants of concern, as well as the constraints presented by site conditions and equipment limitations. Modifications of sampling methodologies will be documented in the appropriate field logbook and discussed in reports summarizing field activities and analytical results. For the purposes of this procedure, soils are those mineral and organic materials not submerged in water for an extended period of time sufficient to support aquatic life.

Equipment/Apparatus

Equipment needed for PID/FID screening of soil samples may include:

- PID/FID instrument
- Clear glass jar
- Aluminum foil
- Ziploc bags

Procedure

When using PID/FID instrument the following procedure must be used:

- Half-fill **either** a glass jar, or a Ziploc® baggie.
 - When using glass jars:
 - Fill jars with a total capacity of 8 oz. or 16 oz.
 - Seal each jar with one (1) or two (2) sheets of aluminum foil with the screw cap applied to secure the aluminum foil.
 - When using Ziploc® baggies:
 - Half fill bags from the split spoon or the excavation.
 - Zip to close.
- Vigorously shake the sample jars or bags for at least thirty (30) seconds once or twice in a 10- to 15-minute period to allow for headspace development.
- If ambient temperatures are below 32 degrees Fahrenheit (0 degrees Celsius) headspace development is to be within a heated vehicle or building.
- Quickly insert the PID/FID sampling probe through the aluminum foil. If plastic bags are used, unzip the corner of the bag approximately one to two inches and insert the probe or insert the probe through the plastic. Record the maximum meter response (should be within the first 2 to 5 seconds). Erratic responses should be discounted as a result of high organic vapor concentrations or conditions of elevated headspace moisture.
- Record headspace screening data from both jars or bags for comparison.

- Calibration will be checked/adjusted daily. In addition, all manufacturers' requirements for instrument calibration will be followed.
- If sample jars are re-used in the field, jars will be cleaned according to field decontamination procedures. In addition, headspace readings must be taken to ensure no residual organic vapors exist in the cleaned sample jars.
- Plastic bags will not be reused.

Standard Operating Procedure B-6: 1920F1 Pressure-Vacuum Soil Water Samplers- Operating Instructions

1920F1

OPERATING INSTRUCTIONS

1920F1 Pressure-Vacuum Soil Water Samplers

November 2011

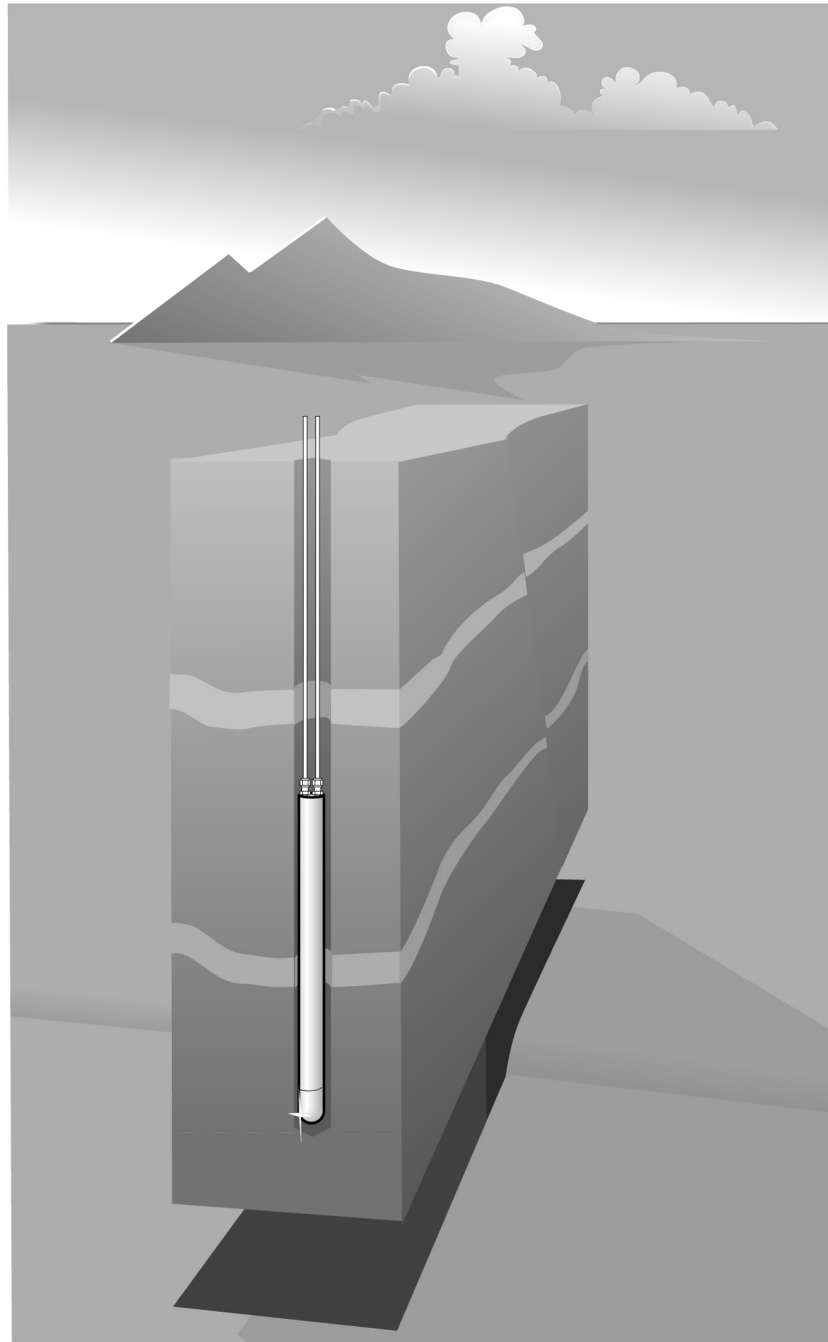

SOILMOISTURE EQUIPMENT CORP.
P.O. Box 30025, Santa Barbara, California 93130 USA
Phone: (805) 964-3525 • Fax: (805) 683-2189
e-mail: sales@soilmoisture.com • Web www.soilmoisture.com



TABLE OF CONTENTS

| | |
|--|---------|
| History/General Uses | Page 3 |
| Operating Principles | Page 4 |
| Your New Pressure-Vacuum Soil Water Sampler..... | Page 6 |
| Unpacking | Page 6 |
| Assembly | Page 6 |
| Not Liable for Improper Use..... | Page 7 |
| Acquaint Yourself with the Parts | Page 8 |
| Requirements Prior to Use and How to Operate | Page 8 |
| Attaching the Access Tubes..... | Page 8 |
| Pressure Testing Before Installation | Page 8 |
| Coring the Hole | Page 8 |
| Preparing The Hole Using a Slurry and Backfilling The Hole | Page 9 |
| Alternate Methods for Sampler Installation | Page 10 |
| Protecting the Access Tubes..... | Page 12 |
| Collecting a Sample in the Sampler..... | Page 12 |
| Recovering a Sample from the Soil Water Sampler | Page 13 |
| Maintenance and Precautions | Page 14 |
| Re-wetting The Sampler | Page 14 |
| Spare Parts and Accessories | Page 15 |

HISTORY/GENERAL USES

Soil Water Samplers had their origin back in 1961 when we cooperated with Dr. George H. Wagner at the University of Missouri to manufacture a porous ceramic cup for collecting soil water samples. The outgrowth of this work was our first commercial Soil Water Sampler, Model 1900 Soil Water Sampler. Since that time, these samplers have been generally accepted as an ideal tool for in situ collection of soil water samples for a great variety of soil moisture monitoring work.

The initial and most extensive use of these Samplers was made by Pennsylvania State University, largely under the direction of Dr. L. T. Kardos and others, on the Pennsylvania Waste Water Project. Modifications of the original 1900 Soil Water Sampler by Richard R. Parizek and Burke E. Lane at Pennsylvania State University, reported on in the Journal of Hydrology, produced a pressure-vacuum type unit. Since that time, we have made available commercially the Model 1920 Pressure-Vacuum Soil Water Sampler. Some of our Soil Water Samplers have been in continuous use for several years and still yield satisfactory soil moisture samples.

All of our ceramics are made from formulations which contain various proportions of kaolin, talc, alumina, ball clay, and other feldspathic materials, using proprietary formulas developed through research and experience accumulated over more than 4 decades.

Our samplers find applications not only in research work such as quantitative chemical analysis of soil water, but also for pollution control purposes in monitoring moisture under sanitary landfills, irrigated areas with wastewater, and areas where reclaimed or recycled water is used on a routine basis to assure compliance with government standards.

Soilmoisture's line of Soil Water Samplers has proven to be an excellent and reliable means for obtaining soil water samples from both saturated and unsaturated soils at depths ranging up to several hundred feet. Soilmoisture's Soil Water Samplers, which are also referred to as "suction lysimeters" or "lysimeters", have

OPERATING PRINCIPLES

been in general use around the world for many years.

Soil water is held largely under a state of tension (negative pressure) within the soil by capillary forces. The capillary force is the sum of the adhesive and cohesive forces. The adhesive force is characterized as the attraction of water for soil solids (soil and organic matter). Cohesive force is characterized as the attraction of water for itself. Adhesive force is far greater than the cohesive force.

Water is naturally attracted to soil particles (by its adhesive quality) and “sticks” to the surface of each particle and in the various sized “capillary” spaces or “pores” between the soil particles. When the soil is very wet, the large pores fill with water. This “excess” water has no direct surface contact with the soil and is held cohesively, one water molecule to another, and can move quite freely. As a soil dries out, the “excess” water first evaporates as it requires less energy to break the cohesive bonds. The remaining water, held tightly inside the capillary spaces by adhesive qualities, requires more energy to remove it from the soil.

The following illustration (see Figure 1) shows the increasing force required to remove water from the small-sized capillary pores compared to the large pores as the soil dries out. When the remaining water is held only in extremely small pore spaces, it requires more energy to remove the water from these pores. Even though there may be a considerable volume of water in the soil, the tension that holds the water determines how readily it can be removed.

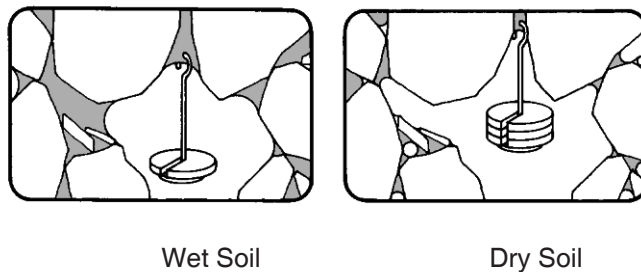

Figure 1.

This tension that determines how moisture moves in the soil is referred to as “soil water tension”, “negative pore pressure”, or “soil suction”. For simplicity’s sake we refer to this tension as “soil suction” in these instructions, but keep in mind that negative pressure is the most descriptive term.

The following graph shows the relationship between the percent of moisture in a soil and the soil suction required to remove the moisture from three types of soil: clay, loam, and sand.

The graph (see Figure 2) illustrates that it is easier to remove water from a sandy soil with 10% moisture, than it is to remove water from a clay soil with 30% moisture. This is because the water in the clay soil is held in very small capillary spaces within the soil particles under a higher soil suction, whereas the sandy soil holds water in large capillary spaces under a lower soil suction.

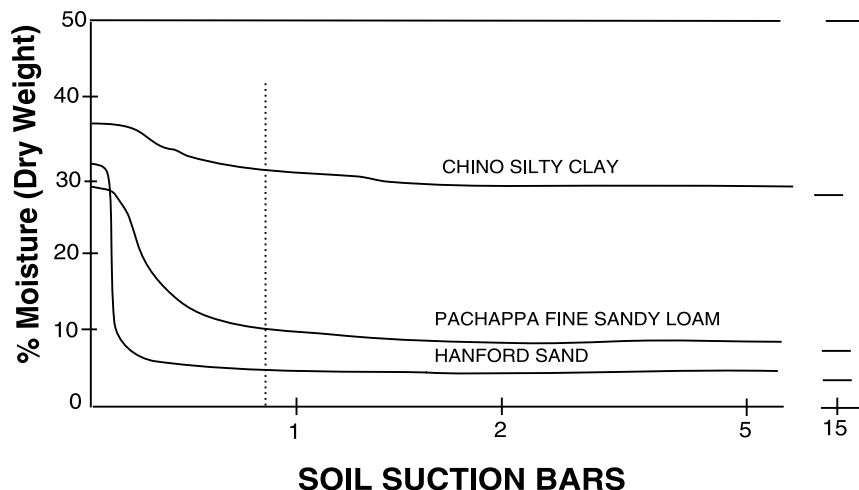

Figure 2.

Soilmoisture's Soil Water Samplers allow water to be removed from the soil by creating a vacuum (negative pressure or suction) inside the sampler greater than the soil suction holding the water in the capillary spaces. This establishes a hydraulic gradient for the water to flow through the porous ceramic cup and into the sampler. Note: when evaluating soil suction ratings of a ceramic plate or cup, a positive pressure rating is used. Water can be held at tensions far greater than 1 atm (the limit for vacuum-type measurements). Positive pressure can force water out of capillary pores equivalently as negative pressures, and is the practical method for evaluation of soil suction.

In practice, a vacuum is drawn in the Soil Water Sampler that exceeds the soil water tension. Then liquid water will flow to the ceramic cup due to the potential gradient (i.e. water will move from less negative potential to more negative potential). The practical limit for water flow in soils is about 65 cb (centibar) (although in some soils, the value can approach 85 cb). When soil moisture tensions exceed 2 bars, the wetted meniscus in the ceramic pores will break and the Soil Water Sampler will appear to be unable to hold vacuum. The ceramic cup will have to be rewetted to hold a vacuum and soil moisture tensions will have to decrease to less than 85 cb before water can again be moved toward the ceramic cup.

Additional information on the advantages and disadvantages of Soil Water Samplers in general can be found in Chapter 19, "Compendium of In Situ Pore-Liquid Samplers for Vadose Zone" (Dorrance et al.), of the ACS Symposium on Groundwater Residue Sampling Design (April 22-27, 1990) and the ASTM Designation D4696-92 "Standard Guide for Pore-Liquid Sampling from the Vadose Zone" (Vol. 04.08 Soil and Rock (I): D4696).

YOUR NEW PRESSURE-VACUUM SOIL WATER SAMPLER

Unpacking

Remove all packing materials and check the Soil Water Sampler for any damage that may have occurred during shipment.

If the Sampler is damaged, call the carrier immediately to report it. Keep the shipping container and all evidence to support your claim.

Assembly

The standard 1920F1 Pressure-Vacuum Soil Water Sampler was assembled and tested prior to shipment.

All other accessory items necessary for proper use are discussed later in these instructions and are listed on page 16. Please read all instructions thoroughly before installing the Sampler. To assure optimum cleanliness of the assembly, no grease or organic solvents have been used in its manufacture.

Not Liable for Improper Use

Soilmoisture Equipment Corp. is not responsible for any damage, actual or inferred, for misuse or improper handling of this equipment. The Pressure-Vacuum Soil Water Samplers, Models 1920F1, are to be used solely as directed by a prudent individual under normal conditions in the applications intended for this equipment.

ACQUAINT YOURSELF WITH THE PARTS

The Pressure-Vacuum Soil Water Sampler (Model 1920F1) comes fully assembled. The Pressure-Vacuum Soil Water Sampler (see Figure 3) is constructed of a 1.9 inch O.D. PVC tube (made of FDA-approved material) with a 2 bar porous ceramic cup bonded to one end. The serviceable end of the Sampler is completely sealed and two 1/4-inch tube connectors protrude from the top. The white tube connector indicates the "Pressure/Vacuum" side and is used exclusively for pressurizing and evacuating the Sampler. The green tube connector is used to recover the collected sample.

Two 1/4-inch O.D. polyethylene access tubes are used for pressurizing and recovering samples which are terminated in neoprene tubing. Clamping rings are used to clamp the neoprene to keep the Sampler under negative pressure (not shown here).

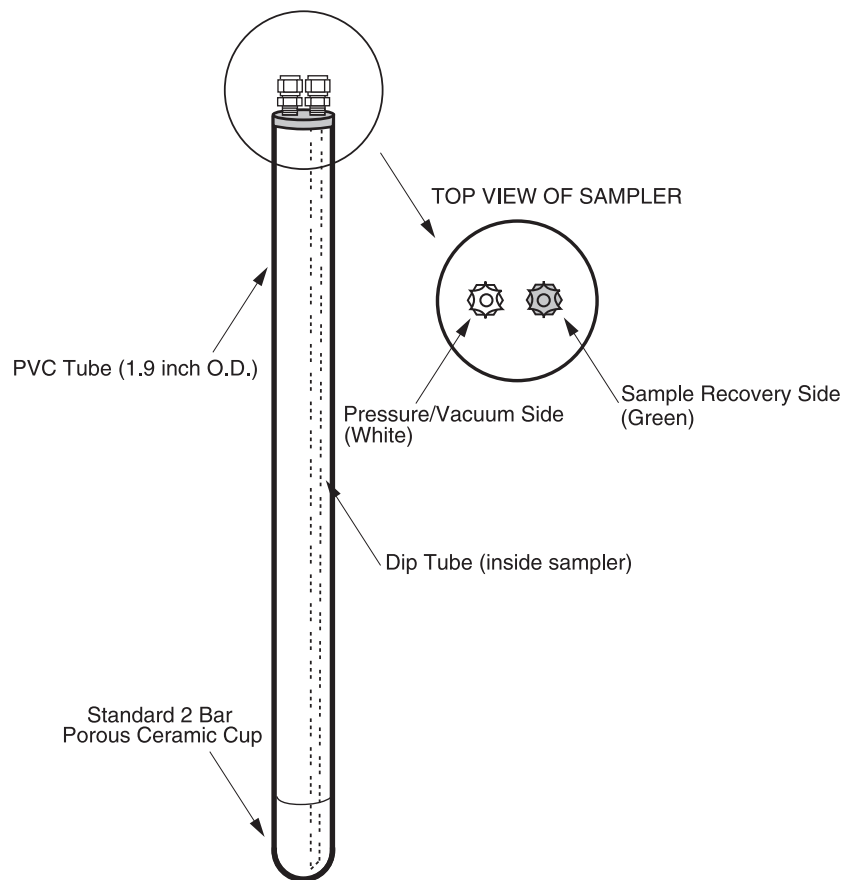

Figure 3. Pressure-Vacuum Soil Water Sampler

REQUIREMENTS PRIOR TO USE AND HOW TO OPERATE

Attaching the Access Tubes

Once the depth and location for the Pressure-Vacuum Soil Water Sampler have been established, you must determine the required length for the access tubes before they are cut and attached to the Soil Water Sampler.

The access tubes are generally made of 1/4-inch O.D. polyethylene, nylon, or teflon tubing. Each access tube is inserted into the loosened top portion of the tube connector located on the serviceable end of the Soil Water Sampler. Tighten the fittings to finger tightness. We recommend using 2 different colors of tubing to differentiate between the two connectors in order to eliminate mistakes in identifying the access tubes once the Sampler is placed in the soil. Soilmoisture offers both black and green polyethylene tubing, models 1903L and 1904L respectively.

Pressure Testing Before Installation

We highly recommend pressure testing the complete Sampler assembly prior to installation. Your prior testing will confirm the integrity of all joints and components.

After allowing the ceramic portion of the Sampler to soak in water for approximately two hours, a sustained pressure of 20 psi can be applied to the submerged Sampler, associated tubing, and connectors. Continuous bubble formation indicates leakage and shows the exact location of any leak.

Coring the Hole

The Pressure-Vacuum Soil Water Sampler, Model 1920F1, may be installed at any depth up to a maximum of 50 feet.

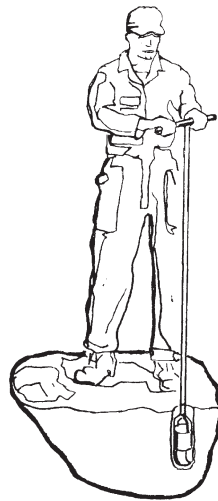

Figure 4a.



Figure 4b.

In rock-free, uniform soils at shallow depths, use a 2-inch screw or bucket auger for coring the hole (Figure 4a). If the soil is rocky, a 4-inch auger should be used. The soil is then sifted (Figure 4b) through a 2mm mesh screen or 2mm sieve to free it of pebbles and rocks.

This will provide a reasonably uniform backfill soil for filling in around the Soil Water Sampler. Soilmoisture has suitable soil augers for this purpose (234 Series augers). There are other methods for installing the Soil Water Sampler to be used, largely dictated by the type of soil you are dealing with and the tools available. The primary concern in any method of installation is that the porous ceramic cup of the Sampler be in tight, intimate contact with the soil so that soil water can move readily from the pores of the soil through the pores in the ceramic cup and into the Soil Water Sampler.

Preparing The Hole Using a Slurry and Backfilling The Hole

After the hole has been cored, mix sifted soil with water to make a slurry which has a consistency of cement mortar. This slurry is then poured down to the bottom of the cored hole to insure a good soil contact with the porous ceramic cup (see Figure 5a).

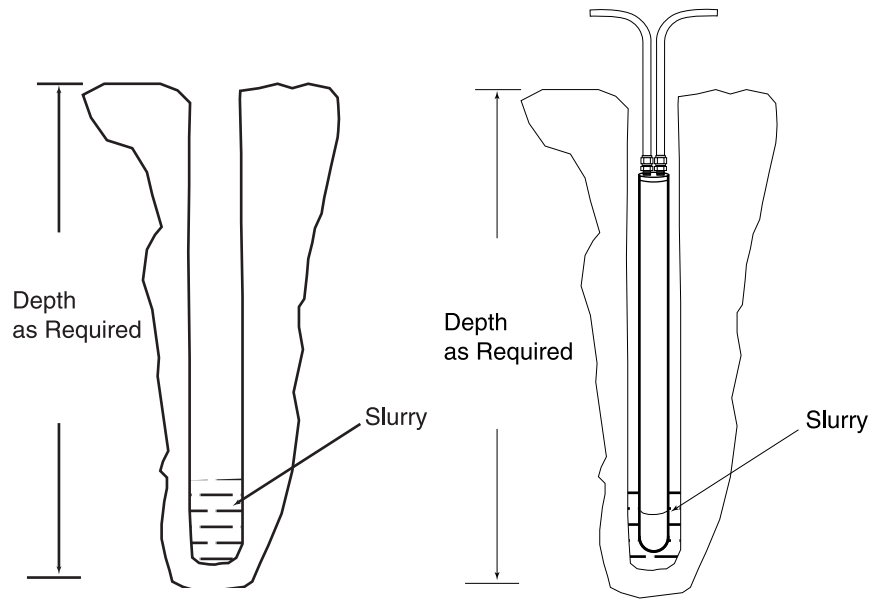

Figure 5a.

Figure 5b.

Immediately after the slurry has been poured, insert the Soil Water Sampler down into the hole so that the porous ceramic cup is completely embedded in the soil slurry (see Figure 5b).

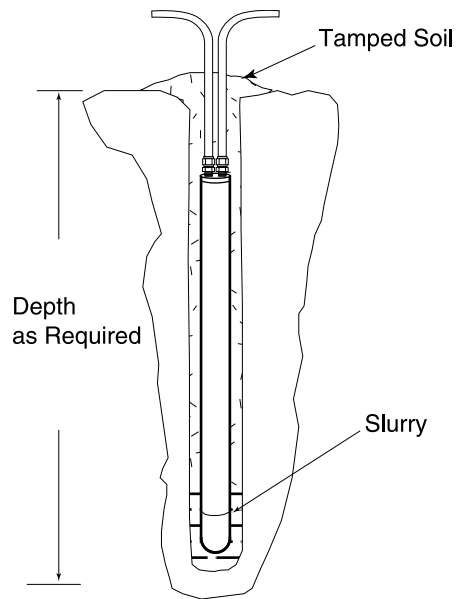

Figure 6.

Backfill the remaining area around the Sampler with sifted soil which is free of pebbles and rocks, a 2mm sieve is popular for this. Tamp the soil firmly to prevent surface water from running down the cored hole, or make a bentonite seal. (see Fig. 6)

Alternate Methods for Sampler Installation

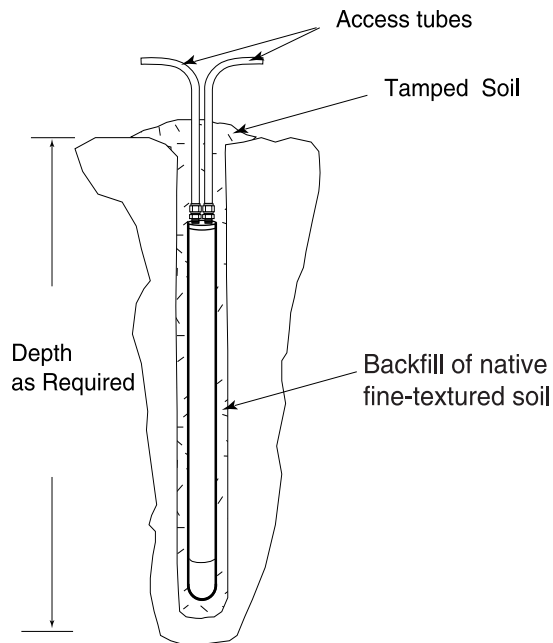

Figure 7.

If the soil into which the Sampler is being installed is fine-textured and free of rocks, a slurry may not be necessary. Core the hole to the desired depth, insert the Soil Water Sampler and backfill the hole with native soil, tamping continuously to insure good soil contact with the porous ceramic cup and complete sealing of the cored hole (see Figure 7).

In a coarse-textured or rocky soil, it may be difficult to make a suitable slurry from the existing soil. A slurry can be made using silica flour, which is then used to establish good contact between the ceramic cup and the soil. For a 2-inch diameter hole, 1 lb. of silica flour is needed, while a 4-inch diameter hole will require 4 lbs. of silica. Mix the silica with water to produce a slurry with a consistency of cement mortar.

Core the hole to the desired depth, and pour in about 1/4 of the silica slurry. Insert the Soil Water Sampler and pour in the remainder of the slurry so that the slurry completely covers the ceramic cup. Backfill the hole with sifted soil (free of pebbles and rocks), tamping continuously with a metal rod to prevent surface water from channeling down between the soil and the body tube of the Sampler (see Figure 8).

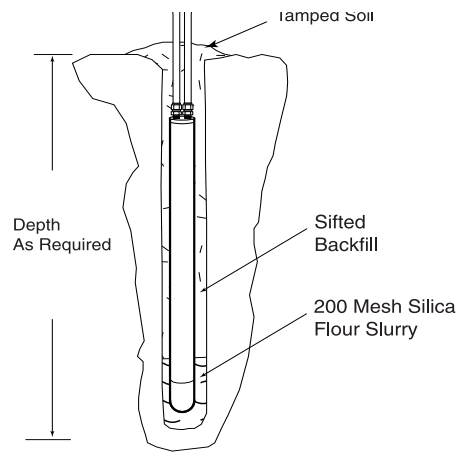

Figure 8.

To ensure that disturbed soil resulting from the installation of the Sampler does not affect the movement of water to the Sampler, Bentonite clay plugs can be installed. Core the hole a few inches deeper than the desired depth, and pour in several inches of wet Bentonite clay (see Fig. 9). This will isolate the Sampler from the soil below. Pour in 1/4 of the slurry, either of soil or of Silica, and insert the Soil Water Sampler. Pour the remainder of the slurry around the cup of the Soil Water Sampler. Backfill with native soil to a level just above the Soil Water Sampler and again add sufficient Bentonite as a plug to further isolate the Soil Water Sampler and guard against possible channeling of water down the hole. Backfill the remainder of the hole slowly, tamping continuously with a metal rod using native soil, free of pebbles and rocks.

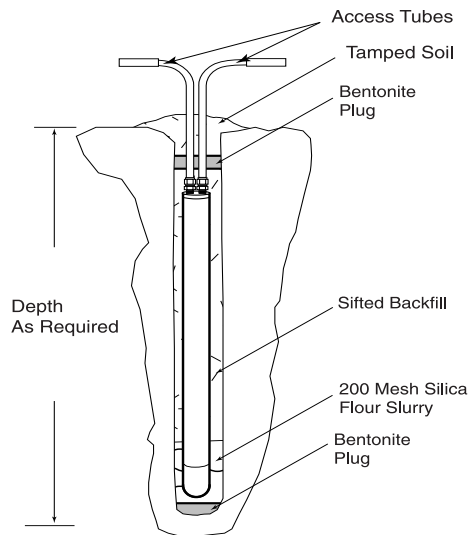

Figure 9.

Protecting the Access Tubes

After installation, the access tubes from the Sampler are terminated with a 6-inch length of neoprene tubing (MRT003) above the Sampler installation. Or, if conditions require, place the neoprene-terminated access tubes in a trench, terminating above the soil surface at a remote location. We recommend that the access tubes be protected inside a conduit tube running from the top of the Sampler to the termination at the surface. At the surface level, take care that the access tubes are safe from damage by mechanical equipment or animals. Do not cover the surface area directly above the Sampler in any manner that would interfere with the normal percolation of soil water down to the depth of the Sampler, otherwise the obstruction could have an adverse affect on your soil water sample.

Collecting A Sample in the Sampler

To collect a sample, the discharge access tube is closed using a clamping ring, and the vacuum port of the hand pump is connected to the Pressure-Vacuum access tube. The pump is then used to create a vacuum of about 60 cb inside the Sampler, which is indicated on the gauge connected to the pump (see Fig. 10).

Figure 10.

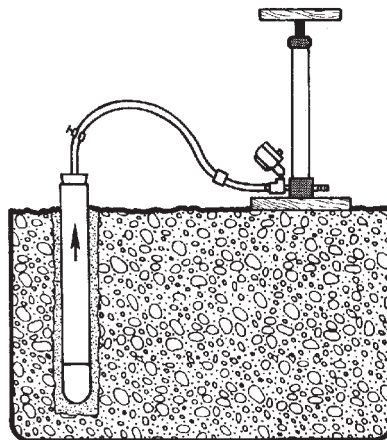

The vacuum within the Sampler causes the water to move from the soil, through the pores of the porous ceramic cup, and into the Sampler. The rate at which the soil

solution will collect within the Sampler depends on the capillary conductivity of the soil, the soil suction value within the soil (as measured with tensiometers), and the amount of vacuum within the Sampler. In moist soils of good conductivity, at field capacity (10 to 30 cb of soil suction as read on a tensiometer) substantial soil water samples can be collected within a few hours. Under more difficult conditions it may require several days to collect an adequate sample.

In general, a vacuum of 50 to 85 cb is normally applied to the Soil Water Sampler. In very sandy soils, however, it has been noted that very high vacuums applied to the Soil Water Sampler seem to result in a lower rate of collection of the sample than a lower vacuum. It is our opinion that in these coarse, sandy soils, the high vacuum within the Sampler may deplete the moisture in the immediate vicinity of the porous ceramic cup reducing the capillary conductivity, which creates a barrier to the flow of water to the cup. In loams and gravelly clay loams, users have reported collection of 300 to 500 ml of solution over a period of a day with an applied vacuum of 50 cb, when soils are at field capacity. At waste water disposal sites, users have obtained 1500 ml of sample solution in 24 hours following cessation of irrigation with 1 to 2 inches of waste water on sandy or clay loam soil.

To recover a soil water sample, remove the Pressure-Vacuum tube from the vacuum port of the pump, and attach the tube to the pressure port. Place the discharge access tube in a small collection bottle and remove both clamping rings. Apply a few strokes on the hand pump to develop enough pressure within the Sampler to force the collected water out of the Sampler and into the collection bottle (see Fig. 11).

Recovering a Sample from the Soil Water Sampler

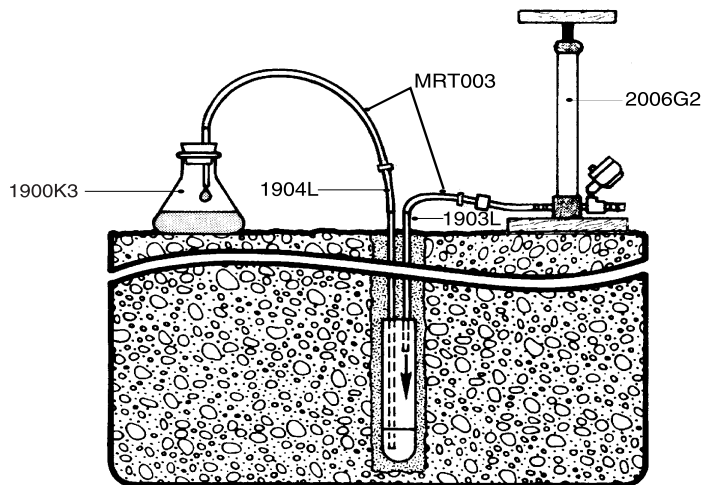

Figure 11.

Subsequent samples are collected by again creating a vacuum within the Sampler and following the steps as outlined above.

MAINTENANCE AND PRECAUTIONS

There are no maintenance requirements for the Pressure-Vacuum Soil Water Sampler other than protecting the access tubes from damage. Tube ends should be covered or plugged to prevent debris from entering the tubes and later contaminating the Sampler.

Freezing conditions will not damage the subsurface parts of the Samplers. The Samplers are normally left permanently in place all year round. Water may freeze in the sample line near the surface during saturated freezing conditions. Be sure all the water is removed from the sample line before clamping it for the next sample.

Rewetting The Sampler

If the soil suction exceeds 2 bars, the ceramic cup may need to be rewetted to obtain a sample. This is accomplished by pouring approximately 250 ml of deionized water down the sample line (both the pressure-vacuum and the sample lines must be open). After waiting approximately one hour, pressurize the pressure-vacuum line to remove any excess water. A vacuum can be applied after the ceramic cup has been rewetted. If no sample is obtained after following the above rewetting procedure, the soil suction is probably in excess of 85 cb.

SPARE PARTS AND ACCESSORIES LIST

| | |
|--------|---|
| 0922W_ | Bentonite (5 lb., 10 lb., or 50 lb. bag sizes) |
| 0930W_ | Silica Flour (5 lb., 10 lb., or 50 lb. bag sizes) |
| 1900K4 | Wide-mouth Sample Bottle, polypropylene - 1,000 ml (autoclavable) |
| 1902K3 | Centralizer with Centralizer Adapter Kit |
| 1902K4 | 1-1/2" Stainless Steel Coupling Assembly |
| 1903L_ | Black Polyethylene Tubing (100 ft., 500 ft., or 1,000 ft. rolls) |
| 1904L_ | Green Polyethylene Tubing (100 ft., 500 ft., or 1,000 ft. rolls) |
| 2006G2 | Pressure-Vacuum Hand Pump (with gauge) |
| 2031G2 | Clamping Rings (per doz.) |
| MRT003 | Neoprene Tubing, 3/16-inch I.D. x 1/16-inch wall (10ft, 25ft, or 50ft, rolls) |

Note:

All Pressure-Vacuum Soil Water Samplers come in 6-inch, 12-inch, 24-inch or 36-inch lengths. They can also be special ordered with either a 1 Bar High Flow (30 ft. maximum depth range) or 1/2 Bar Standard (15 ft. maximum depth range) porous cup instead of the standard 2 Bar cup. Please contact our Sales Department for further details.

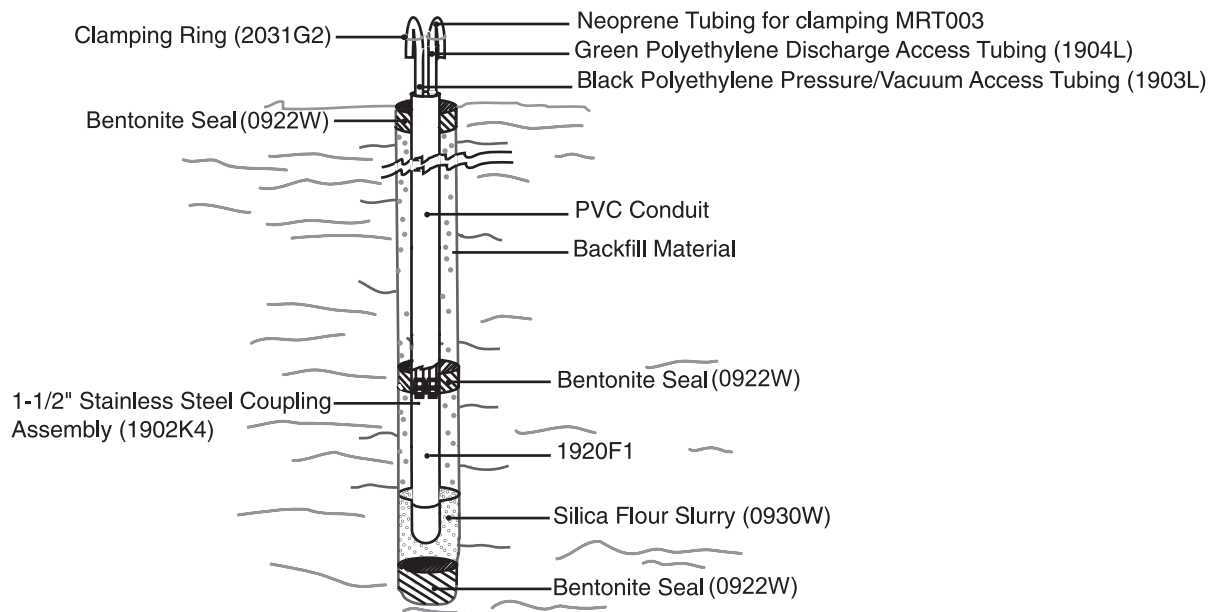

Figure 12. Complete sampler installation with accessories



Standard Operating Procedure B-7: Surface and Excavation Soil Sampling

Standard Operating Procedure B-7: Surface and Excavation Soil Sampling

This standard operating procedure (SOP) is applicable to the collection of representative soil samples. This SOP is generic in nature and may be modified in whole or part to meet the handling and analytical requirements of the contaminants of concern, as well as the constraints presented by site conditions and equipment limitations. Modifications of sampling methodologies will be documented in the appropriate field logbook and discussed in reports summarizing field activities and analytical results. For the purposes of this procedure, soils are those mineral and organic materials not submerged in water for an extended period of time sufficient to support aquatic life, and surface soil is soil that can be collected from the ground surface or an excavation sidewall or bottom using hand-driven equipment such as scoops, hand augers, or soil recovery probes.

Equipment/Apparatus

Equipment needed for collection of soil samples may include:

- Maps/Plot plan
- Safety equipment
- Tape measure
- Survey stakes, flags,
- Camera
- Stainless steel, plastic, or other appropriate composition bucket or bowl
- 4-oz., 8-oz., one-quart, or other appropriately-sized wide mouth jars w/Teflon lined lids
- Ziploc plastic bags
- Logbook
- Sample jar labels
- Chain of Custody records, field data sheets
- Cooler(s)
- Ice
- Decontamination supplies/equipment
- Spade or shovel
- Spatula
- Scoop
- Trowel
- Soil Recovery Probe

Decontamination Procedures

Decontamination Prior to Sampling

Proper decontamination of sampling equipment is essential to minimize the possibility of cross-contamination of samples. Nondedicated equipment used for sampling various environmental media (soil, groundwater, surface water, etc.) will be cleaned before its initial use in the field and again before use at each subsequent sampling site.

All nondedicated sampling equipment will be new, or will be decontaminated prior to its initial use on-site. Decontamination procedures will include the following steps:

1. Wash the equipment in a nonphosphate detergent.
2. Rinse with potable tap water.
3. Rinse with deionized (DI) or distilled water.

To the extent practicable, single-use sampling equipment and materials will be used for the collection of all environmental samples. The materials used will be new and clean, and will be placed in plastic for transport to the site. Once used, this equipment will be placed in plastic bags and managed as investigation-derived waste material.

In-Field Sampling Decontamination Procedures

As described above, this sampling protocol describes multiple methods for soil sample collection. The decontamination procedures described below will be relied upon in the field as appropriate for equipment decontamination.

Nondedicated equipment that is to be used at additional locations at the site will be field-decontaminated between sampling locations. The field decontamination of sampling equipment will take place at the sampling location. All decontamination water will be contained in 5-gallon plastic buckets and combined with other decontamination wastewater.

If nondisposable, nondedicated field equipment is used, field equipment blanks will be collected at a rate specified in the Quality Assurance Project Plan.

Sample Collection

Discrete Soil Sampling Procedures

In general, discrete samples will be collected using a soil recovery probe with butyrate plastic liners, a hand auger, shovel, or scoop. Soil samples collected with a scoop, shovel, hand auger, or similar tool may be placed in a stainless steel (or other suitable material) bowl or bucket and homogenized. The soil recovery probe samplers are hand-pushed or driven and are capable of collecting a 3/4-inch or 1-inch-diameter by 12-inch long sample. The sample enters directly into a butyrate liner, which is then removed from the sampler for processing. The sampler will attempt to sample soil that is not covered by standing water. However, if standing water is present in a sample location, an attempt will be made to minimize the amount of water in the sample by carefully draining off excess water from the sample tube, or after placing the sample in a mixing pan. Field staff will also take precautions to minimize the amount of grass,

roots, and rocks transferred into the sampling container. Sticks, stones, grass, and/or other debris will be removed from the sample. Excess soil will be returned to the sample location.

Each discrete sample will be described in the field notebook using the Unified Soil Classification System and its collection location flagged and photographed (if possible). Soil samples that will not become composite samples will be placed directly in the appropriate sample containers using a clean plastic or metal spatula, or by using a clean gloved hand. Samples that are collected for VOC analysis using bucket sampling will be taken from an intact portion of soil to minimize VOC loss.

Discrete samples that will become aliquots of a composite sample will be covered or capped as soon as possible after collection. Each butyrate tube or sample container will be labeled and stored on ice pending the composite process.

At locations where samples are to be obtained at depths greater than 1 foot, a 2-inch diameter (or larger) bucket auger or similar device will be used to reach the top of the intended sample interval. A sample will be collected either directly from the auger or a soil recovery probe sampler with butyrate liner will be lowered into the hole to the top of the sample interval and advanced to the intended sample depth.

Composite Soil Sampling Procedures

Composite samples will be prepared from the discrete samples following collection of the required number of discrete sample specified for the sampling area. Each discrete sample will be removed from its butyrate liner either using a stainless steel extruder, or by cutting the butyrate tube lengthwise and lifting or sliding the sample from the tube onto a clean sheet of aluminum foil; discrete samples collected by hand auger, scoop or other similar method will be removed from the sample container and placed on a clean sheet of aluminum foil. After removing sticks, grass, stones, and other debris, each discrete sample will be separated into quarters – cores will be cut lengthwise into 4 equal portions, while disturbed samples will be homogenized and divided. Three of the four quarters of each sample will then be placed into one of three individual foil pans. The fourth portion of the discrete sample will be placed in a plastic baggie, labeled, sealed, and stored separately for potential individual analysis.

The compositing process of quartering discrete samples will be repeated for successive discrete samples until each of the three pans contains one quarter of each discrete sample. The contents of each aluminum foil pan will then be thoroughly mixed either by hand or by using an electrical or mechanical mixer. Upon completion of the mixing process, the contents of each individual pan will then be combined into one clean pan and again thoroughly mixed, resulting in one homogeneous sample. The composite soil sample will then be placed in the appropriate sample containers, labeled, and placed on ice pending shipment to the laboratory.

VOC Sample Collection Procedures

Soil samples obtained for laboratory analysis of VOCs will be collected in compliance with SW-846 Method 5035. Each soil sample will be obtained directly from the sampling device (i.e., not homogenized) using an En Core™ sampler or field preserved using Method 5035 compatible containers. A description of each sampling procedure is as follows:

EnCore Sampler

The EnCore™ sampler is a single use, commercially available device constructed of an inert composite polymer. EnCore™ uses a coring/storage chamber to collect either a 5-gram or 25-gram sample of cohesive soils. It has a press-on cap with a hermetically vapor tight seal and a locking arm mechanism. Three EnCore™ samplers shall be filled at each sample location using the following procedures:

- Place the EnCore™ sampler into the EnCore™ T-Handle tool.
- Push the sampler into the soil sample until the small o-ring on the plunger of the EnCore™ sampler is visible in the T-Handle viewing hole.
- Wipe off any excess soil from the coring body exterior using a clean paper towel.
- Place the cap on the end of the EnCore™ sampler and twist to lock the cap into place.
- Remove the sampler from the T-Handle and lock the plunger by rotating extended plunger rod fully counterclockwise until the plunger wings rest firmly against the plunger tabs.
- Place the label on the sampler and place the sampling into a labeled EnCore™ sampler bag and zip closed.
- Place the filled EnCore™ samplers in a cooler with ice for overnight shipment to the laboratory using standard chain-of-custody procedures. The soil samples must be prepared for analysis or frozen within 48 hours of sample collection.

Field Preservation

The procedures for the field preservation method are as follows:

- Push a one-time use plastic sampling tool such as a Terra Core™ sampler into the soil to be samples to collect an approximately 5-gram sample aliquot.
- Transfer the 5-gram aliquot to laboratory provided, pre-preserved, 40-milliliter vials containing a specific amount of methanol, sodium bisulfate, and/or organic-free water. The number of vials provided with each preservative will vary by the laboratory performing the analysis. One unpreserved container shall also be filled to allow for laboratory calculation of the sample dry weight.
- Label each sample and place in a cooler with ice for overnight shipment to the laboratory using standard chain-of-custody procedures.

Sample Description and Field Documentation

After samples for chemical and physical analysis have been prepared, a visual soil or lithologic description of each sample will be made according to the Unified Soil Classification System (USCS), and will be recorded in a bound log notebook. Each sampling location will be photographed, and the approximate location will be placed on a site map and recorded in the field notebook.

Residual soil from the compositing process and stored individual discrete sample portions will be disposed in accordance with the Sampling and Analysis Plan.

Appendix C

Infiltration and Mounding Calculations

Infiltration and Mounding Calculations

Field-Scale Soil Flushing Pilot Test, NERT Site, Henderson, Nevada

The rate at which flushing water is applied during the field-scale soil flushing pilot test will depend on the characteristics of the subsurface. An estimate of the maximum soil flushing rate and the rate to minimize unacceptable groundwater mounding was performed using available data to provide preliminary sizing and anticipated applications rates for the Treatability Study Work Plan for In-Situ Soil Flushing at the NERT Site. The sizing of the field-scale system will be refined once additional data has been collected as discussed in Section 5 of the Work Plan.

INFILTRATION RATE

Green-Ampt Model:

The Green-Ampt Model (Green, W.H. and G. Ampt, 1911), derived from Darcy's Law, is a method of estimating the maximum infiltration rate of water into soil without generating runoff. The model is also implemented to determine hydraulic parameters, such as design flow rates. The equation is shown below:

Equation 1

$$f_p = \frac{K_{sat}(H + S_f + L)}{L}$$

Where:

f_p = The infiltration rate (L/T)

K_{sat} = Saturated hydraulic conductivity (L/T)

H = Recharge basin head at discharge point (L)

S_f = Suction (capillary) head at wetting front (L) = .97 to 25.36 cm for sands

L = Depth to wetting front (L)

For the purposes of this analysis and until steady-state conditions are reached, the suction head and effective hydraulic conductivity are assumed to remain constant, with only the depth to the wetting front and infiltration rate varying with time. If the water depth within the soil flushing pilot cell is held constant, the depth of the wetting front would migrate downward until it reaches the water table where suction head will approach zero. When this occurs, the depth of the wetting front will reach a final value equal to the depth to the water table from the recharge basin bottom. Thus, the following equation will result for steady state infiltration due to a constant head recharge basin as the infiltration rate reaches a steady value:

Equation 2

$$f_p = \frac{K_{sat}(H + L)}{L}$$

Data:

To calculate the maximum possible flushing rate, data for K_{sat} and L were compiled from past investigations. The nearest groundwater monitoring well, M-111A, was removed as a part of the

2010/2011 soil removal action at the Site. The most recent water level at M-111A was 1734.5 feet above mean sea level on June 11, 2010 (Northgate, 2010). This result matches with groundwater contours based on more recent data which indicate that the groundwater elevation in the proposed pilot test location is approximately 1735 feet above mean sea level. The final grade in the proposed soil flushing pilot test location is 1757 feet above mean sea level. Using the approximate water level data and the final grade, the depth to groundwater, L in equation 2, is approximately 22 feet bgs.

The saturated vertical hydraulic conductivities of the soils in the proposed pilot test location are not currently known. Therefore, laboratory measured vertical hydraulic conductivities and porosities were taken from Qal soils at the site in an effort to match the depths and lithology over which the soil flushing system will function in the vadose zone. This data is shown below:

Table 1. QAL Soil Matrix Data at Similar Depths to the Proposed Soil Flushing Pilot

| Porosity and Vertical Hydraulic Conductivity | | | | | |
|--|----------------|-----------|--------------|---------------------------------|------------------|
| Well ID | Depth (ft bgs) | Lithology | Porosity (-) | Vertical Hydraulic Cond. (ft/d) | Test Method |
| RSAL6-0.5BSPLP | 0.5 | Qal | 0.36 | 1.75E-01 | Lab (ASTM D5084) |
| RSAU5-0.5BSPLP | 0.5 | Qal | 0.34 | 2.60E-02 | Lab (ASTM D5084) |
| RSAR3-0.5BSPLP | 0.5 | Qal | 0.37 | 2.67E-01 | Lab (ASTM D5084) |
| SA30-9BSPLP | 9 | Qal | 0.33 | 5.91E-01 | Lab (ASTM D5084) |
| SA56-10BSPLP | 10 | Qal | 0.38 | 4.24E+00 | Lab (ASTM D5084) |
| RSAM3-10BSPLP | 10 | Qal | 0.40 | 3.37E-01 | Lab (ASTM D5084) |
| SA166-10BSPLP | 10 | Qal | 0.36 | 4.54E-01 | Lab (ASTM D5084) |
| SA182-10BSPLP | 10 | Qal | 0.33 | 1.02E+00 | Lab (ASTM D5084) |
| RSAJ3-10BSPLP | 10 | Qal | 0.34 | 2.59E-01 | Lab (ASTM D5084) |
| SA64-10BSPLP | 10 | Qal | 0.35 | 3.45E-02 | Lab (ASTM D5084) |
| SA102-10BSPLP | 10 | Qal | 0.34 | 2.64E-01 | Lab (ASTM D5084) |
| SA128-10BSPLP | 10 | Qal | 0.38 | 1.69E-01 | Lab (ASTM D5084) |
| SA148-10BSPLP | 10 | Qal | 0.36 | 4.64E-01 | Lab (ASTM D5084) |
| RSAQ4-10BSPLP | 10 | Qal | 0.32 | 1.58E-01 | Lab (ASTM D5084) |
| RSAN8-10BSPLP | 10 | Qal | 0.37 | 5.22E-01 | Lab (ASTM D5084) |
| RSAQ8-10BSPLP | 10 | Qal | 0.37 | 1.23E+00 | Lab (ASTM D5084) |
| SA34-10BSPLP | 10 | Qal | 0.36 | 3.92E-01 | Lab (ASTM D5084) |
| RSAI7-10B | 10 | Qal | 0.38 | 3.89E-02 | Lab (ASTM D5084) |
| SA52-15BSPLP | 15 | Qal | 0.48 | 4.44E-01 | Lab (ASTM D5084) |
| RSAU4-20BSPLP | 20 | Qal | 0.36 | 1.04E+00 | Lab (ASTM D5084) |
| RSAL6-28BSPLP | 28 | Qal | 0.37 | 4.34E+00 | Lab (ASTM D5084) |
| RSAN8-28BSPLP | 28 | Qal | 0.31 | 2.26E+00 | Lab (ASTM D5084) |
| SA52-28BSPLP | 28 | Qal | 0.40 | 1.20E+00 | Lab (ASTM D5084) |
| RSAQ8-31BSPLP | 31 | Qal | 0.52 | 6.99E-01 | Lab (ASTM D5084) |

| | | | | | |
|-----------------|----|-----|-------------|-----------------|------------------|
| SA34-31BSPLP | 31 | Qal | 0.58 | 6.34E-02 | Lab (ASTM D5084) |
| Average: | | | 0.38 | 8.27E-01 | |

With the above data, the infiltration rate can be solved for:

$$f_p = K_s(H + L)/L = 0.827(1 \text{ ft} + 22 \text{ ft})/22 \text{ ft} = 0.86 \text{ ft/day}$$

Equation 3

This value represents the estimated maximum infiltration rate for saturated soils.

GROUNDWATER MOUNDING

The saturated soil conductivity represents the maximum infiltration rate that can be achieved under saturated conditions; however the actual infiltration rate will be dependent on the potential for groundwater mounding. When water is added continuously to the subsurface it can begin to mound at low permeability layers, such as the groundwater table, making the infiltrating fluid move horizontally along restricting layer. This is a concern for the pilot test because a large mound may force perchlorate laden flushing fluids outside of the capture zone of the GWETS.

Hantush Equation and AQTESOLVE Software:

The Hantush equation presented in Equation 4, below, was used to predict the maximum height of the water table beneath the rectangular recharge area of the soil flushing pilot cell.

Equation 4

$$h^2 - h_i^2 = \left(\frac{f_p}{2K_h}\right)(vt) \left[S\left(\frac{1+x}{\sqrt{4vt}}, \frac{a+y}{\sqrt{4vt}}\right) + S\left(\frac{1+x}{\sqrt{4vt}}, \frac{a-y}{\sqrt{4vt}}\right) + S\left(\frac{1-x}{\sqrt{4vt}}, \frac{a+y}{\sqrt{4vt}}\right) + S\left(\frac{1-x}{\sqrt{4vt}}, \frac{a-y}{\sqrt{4vt}}\right) \right]$$

Where:

$$S * (\alpha, \beta) = \text{Integrative term} = \int_0^1 \text{erf}\left(\frac{\alpha}{\sqrt{\tau}}\right) \text{erf}\left(\frac{\beta}{\sqrt{\tau}}\right) d\tau$$

h = Head at given time after recharge begins

h_i = Initial head of aquifer above aquifer base

f_p = Infiltration rate

K_h = Horizontal hydraulic conductivity

$$v = \text{Diffusivity} = \frac{K_h b}{S_y}$$

t = Time elapsed since flushing began

l = Half – length of the recharge basin

a = Half – width of the recharge basin

x = Horizontal distance from the center of the recharge basin

y = Vertical distance from the center of the recharge basin

$$\alpha = \text{Divisional Term 1} = \frac{1+x}{\sqrt{4vt}}, \frac{1-x}{\sqrt{4vt}}; \beta = \text{Divisional Term 2} = \frac{a+y}{\sqrt{4vt}}, \frac{a-y}{\sqrt{4vt}}$$

τ = Integrative variable

erf = Error function

Using AQTESOLVE software, the Hantush equation was solved to estimate the potential for groundwater mounding based on available site data. The following inputs were used to

estimate mounding in AQTESOLVE for three infiltration area sizes – 50 feet square, 100 feet square and 150 feet square:

- Depth to groundwater of 22 feet
- Storage coefficient of 0.065
- Infiltration rate = 0.86 ft/day
- Hydraulic conductivity = 35 ft/day (arithmetic mean for the Qal)
- Infiltration time = 100 days (the time to flush 4 pore volumes at the given infiltration rate)

The results from AQTESOLVE were then imported into Surfer to create the plots shown in Figure 1. As seen in Figure 1, there is significant mounding – mounding of greater than 1 foot, 300 feet from the center of infiltration - predicted for both the 100 and 150 foot square areas. However, the 50 foot square scenario is not estimated to cause significant mounding for the anticipated life of the pilot.

It is noted that the calculations presented herein are based on estimates of hydraulic conductivities and depth to groundwater to develop the preliminary sizing of the pilot cell. The actual size of the pilot cell will be based on field measurements of the saturated hydraulic conductivities of soils in the area of the candidate field-scale soil flushing pilot. As the proposed soil flushing pilot has the potential to result in mounding, piezometers will be installed to monitoring mounding during the pilot test.

Figure 1. Comparison of Mounding as a Function of Design and Hydraulic Conductivity

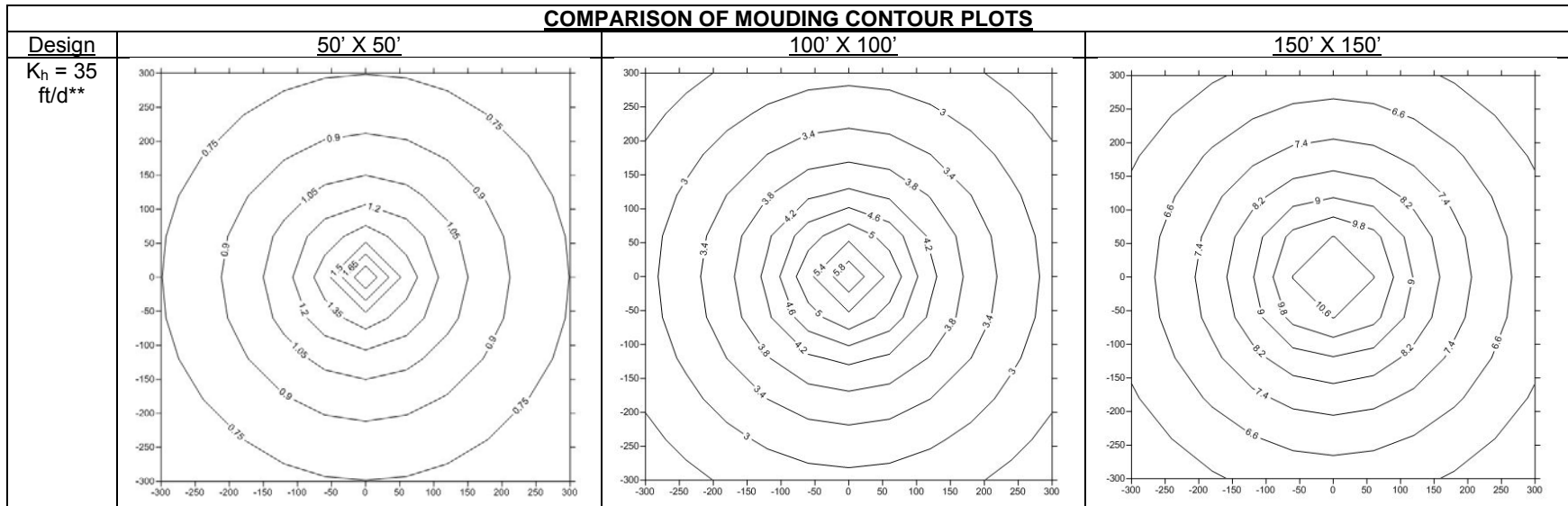

Appendix F
**Groundwater Extraction and Treatment System
Optimization Study: Preliminary Analysis of
Groundwater Capture and Extraction Rates at the
Interceptor and Athens Road Well Fields**

Contents

| | | |
|-----------|--|-----------|
| 1. | Introduction | 1 |
| 2. | Approach | 2 |
| 2.1 | Background | 2 |
| 2.2 | Methodology | 2 |
| 3. | Estimated Capture Zones and Potential Gaps in Capture | 5 |
| 4. | Analysis of Mass Removal | 6 |
| 4.1 | Historical Extraction Rates and Mass Removals | 6 |
| 4.2 | Mass Removal at IWF | 6 |
| 4.3 | Mass Removal at AWF | 7 |
| 5. | Recommendations | 8 |
| 5.1 | Proposed Changes to IWF Extraction Rates | 8 |
| 5.2 | Proposed Changes to AWF Extraction Rates | 8 |
| 5.3 | Startup and Testing of New Wells | 9 |
| 5.4 | Capture Zone Analysis Using the Groundwater Model | 10 |
| 6. | References | 11 |

List of Tables

| | |
|------------|---|
| Table F-1A | Interceptor Well Construction Details |
| Table F-1B | Athens Road Well Construction Details |
| Table F-2 | Current and Proposed Mass Removal at the Interceptor Well Field |
| Table F-3 | Current and Proposed Mass Removal at the Athens Road Well Field |

List of Figures

| | |
|-------------|---|
| Figure F-1 | Interceptor Well Field Capture Zone and Perchlorate Concentrations |
| Figure F-2 | Interceptor Well Field Capture Zone and Total Chromium Concentrations |
| Figure F-3 | Athens Road Well Field Capture Zone and Perchlorate Concentrations |
| Figure F-4 | Athens Road Well Field Capture Zone and Total Chromium Concentrations |
| Figure F-5 | Current Perchlorate Removal at the Interceptor Well Field |
| Figure F-6 | Current Chromium Removal at the Interceptor Well Field |
| Figure F-7 | Current Perchlorate Removal at the Athens Road Well Field |
| Figure F-8 | Current Chromium Removal at the Athens Road Well Field |
| Figure F-9 | Historic and Proposed Perchlorate Mass Removal |
| Figure F-10 | Historic and Proposed Chromium Mass Removal |

List of Attachments

Attachment F-1 Historical Extraction Rates and Mass Removal Plots for all Wells in the Interceptor Well Field

Attachment F-2 Historical Extraction Rates and Mass Removal Plots for all Wells in the Athens Road Well Field

Attachment F-3 Historical Extraction Rates and Mass Removal Plots for all Wells in the Seep Well Field

APPENDIX F

Groundwater Extraction and Treatment System Optimization Study: Preliminary Analysis of Groundwater Capture and Extraction Rates at the Interceptor and Athens Road Well Fields

1. Introduction

The Nevada Environmental Response Trust (the Trust) operates a groundwater extraction and treatment system (GWETS) at the Site to remediate perchlorate and hexavalent chromium from shallow groundwater. The GWETS consists of three extraction well fields: (1) the onsite Interceptor Well Field (IWF) and barrier wall; (2) the Athens Road Well Field (AWF), which is situated approximately 8,200 feet north (downgradient) of the IWF; and (3) the Seep Well Field (SWF) situated approximately 4,500 feet north of the AWF near the Las Vegas Wash. The performance and monitoring of the GWETS are discussed in detail in remedial performance reports submitted to the Nevada Division of Environmental Protection (NDEP) on a semi-annual basis.

The purpose of this appendix is to evaluate groundwater capture at the IWF and the AWF based on current groundwater extraction rates and to propose alternative extraction rates for existing wells and target extraction rates for new wells. The operational changes recommended herein are designed to enhance capture, increase mass removal, and minimize impacts downgradient of the AWF. Further monitoring and analysis of capture and mass removal will be required to evaluate performance of the GWETS and to identify the optimal sustainable extraction rates for individual wells within each well field. Therefore, this study should be considered the first step of an iterative process to enhance performance of these two well fields.

To simplify the analysis, the IWF and the AWF were each analyzed independently (i.e., the effects of one well field on the other were not evaluated). Capture zone analysis of the SWF will be proposed for future studies.

2. Approach

The overall approach of this preliminary analysis is to compare the current estimated capture zones of the IWF and AWF to the extent of the perchlorate and chromium plumes, and then to make recommendations for turning on new wells or adjusting extraction rates at existing wells in order to address the potential gaps in capture and to improve mass removal.

2.1 Background

In December 2010, Northgate prepared a capture zone evaluation, “2010 CZE Report”, to describe groundwater flow and perchlorate and chromium distributions and to evaluate the performance of the GWETS (Northgate, 2010a). The 2010 CZE Report was prepared on behalf of Tronox, the prior owner of the Site. NDEP has reviewed and provided comments on the 2010 CZE Report on April 5, 2011, some of which are being addressed by the Trust; however, this report has not yet been approved by NDEP. The 2010 CZE Report was a revised and expanded version of Northgate’s Interim Capture Zone Evaluation and Vertical Delineation Report dated March 23, 2010, the “2010 Interim CZE Report” (Northgate, 2010b). As part of the development of the 2010 Interim CZE Report and the 2010 CZE Report, new groundwater wells were installed in order to address data gaps. A number of these new wells installed were designed as potential extraction wells that could be used to address gaps in groundwater capture. The construction details of the wells of the IWF and AWF, including the new potential extraction wells in these well fields, are included in Tables F-1A and F-1B, respectively.

The Trust took title to the Site and the GWETS in conjunction with the settlement of Tronox’s bankruptcy proceeding on February 14, 2011. The Trust has been reporting on the performance of the GWETS since this time. In this current annual report (ENVIRON 2012), potential gaps in plume capture have been observed as evidenced by elevated concentrations (primarily of perchlorate, but also chromium) at the ends of the IWF and downgradient of the AWF (see Plates 6 and 7 of the annual reports). The gaps are generally consistent with capture gaps identified in the 2010 CZE Report, and therefore, some of the potential new extraction wells installed previously by Tronox could be utilized to enhance capture in these areas.

In conjunction with the 2010 CZE Report, a groundwater flow model was developed. Following a call between the Trust and NDEP on March 15, 2012, the groundwater flow model, supporting documentation, and responses to NDEP comments on the model were submitted to NDEP on April 25, 2012, and NDEP provided additional comments on the model on August 1, 2012. The Trust is currently addressing NDEP’s most recent comments. Once the groundwater flow model is approved, further analysis of capture and optimization of the GWETS including recommendations on the recharge trenches and the associated “dead zone” between the barrier wall and the former recharge trenches will be performed.

2.2 Methodology

This section provides an overview of the methods used to perform this analysis. More detailed discussions of the methods and results are included in the specific sections cited below.

As presented in Section 3 of this appendix, the current capture zones for the IWF and AWF were estimated based on contour maps of Shallow Zone water elevations collected in May-June

2012 by the Trust and adjacent property owners, including American Pacific Corporation (AMPAC), Olin/Stauffer/Syngenta/Montrose (OSSM), Southern Nevada Water Authority (SNWA), and Titanium Metals Corporation (TIMET). The water elevation contours were generated with KT3D_H2O v3.0 (Karanovic, 2009), a program for kriging water level data that incorporates extraction well pumping rates. Since KT3D_H2O is limited in its ability to account for low or no flow conditions, the water level contours generated by KT3D_H2O near the barrier wall were corrected manually. A similar approach was used to interpret water level data in the 2010 CZE Report. Potential gaps in capture were identified by overlaying the current isoconcentration contours for perchlorate and chromium on the groundwater contours and estimated capture zones.

As presented in Section 4, current and historical perchlorate and chromium mass removal estimates for each well were calculated using available pumping rate data and perchlorate and chromium concentration data for the time period July 1, 2002 to June 30, 2012. Based on the well extraction histories and professional judgment, a maximum sustainable flow rate of each well was estimated. The mass removal for each well was calculated using available extraction rates and chemical concentration measurements. If the measured concentrations were not available, the concentrations were interpolated from the isoconcentration maps available for Second Quarter 2012.

The estimates of mass removal for individual wells were used to recommend adjusted extraction rates for existing wells in order to increase mass removal while accommodating the initial extraction rates of new wells identified to address gaps in capture. The recommended adjusted extraction rates are discussed in Section 5.

The extraction rates at the IWF and AWF were adjusted such that the proposed cumulative extraction rates from each of the well fields do not exceed certain limits due to the following operational and design constraints of the GWETS:

- The GWETS is operating near its design average annual hydraulic loading of 950 gallons per minute (gpm) at the Fluidized Bed Reactors (FBRs) (the design 30-day average maximum flow is 1,000 gpm);
- The on-site chromium treatment plant, referred to as the “GWTP”, is operating near its current operational maximum hydraulic loading of 85 gpm (including the 8-10 gpm of recycle);
- Lift Station 3, which conveys extracted water from the AWF to Lift Station 2, is pumping at close to its maximum sustainable flow of 290 gpm; and
- The pumping at Lift Station 2, which conveys water from the SWF and the AWF to the onsite treatment plant is limited—it has a maximum sustainable flow of 900 gpm—but since Lift Station 2 is downstream of Lift Station 3, it is not directly limiting the flow from the AWF.

Based on these constraints, particularly the limitations of the GWTP and Lift Station 3, which are the most constraining, maximum cumulative extraction rates were set for the IWF and the AWF at 75 and 290 gpm, respectively. Recommendations on upgrades to these components are not

part of the scope of this analysis, but may be part of future studies to enhance the performance of the GWETS.

3. Estimated Capture Zones and Potential Gaps in Capture

Figures F-1 and F-2 show the detailed potentiometric map at the IWF along with the estimated capture zone and perchlorate and chromium isoconcentration contours, respectively. As shown on Figure F-1, the IWF is capturing high concentrations of the perchlorate plume (generally greater than 1,000 mg/L) at the barrier wall. However, on both ends of the barrier wall, lower concentrations of perchlorate appear to be outside of the inferred capture zone of the IWF. The potential capture gap is wider on the western side of the barrier wall where groundwater with perchlorate concentrations higher than 250 mg/L exists outside the capture zone. As seen on Figure F-2 the potential capture gap is visible on the western side of the barrier wall where groundwater with a total chromium concentration of about 0.1 mg/L exists outside of the capture zone. To address this gap, ENVIRON proposes to begin pumping the several new wells, which is described in more detail in the following sections.

Figure F-3 and Figure F-4 show the detailed potentiometric map at the AWF along with the estimated capture zone and perchlorate and chromium isoconcentration contours, respectively. Pumping at the AWF is already partially dewatering the alluvium as indicated by a localized area of unsaturated alluvium in the middle of the AWF, where the contact between alluvium and the Upper Muddy Creek Formation (UMCf) is relatively shallow, creating a subsurface geologic feature known as the UMCf ridge. The paleochannels on either side of the UMCf ridge are preferential pathways for groundwater flow. As can be seen on Figures F-3 and F-4, there is a potential gap in the capture zone identified at the center of the AWF centered at PC-149 and extending to the east and west past wells PC-148 and PC-150, respectively. To address this gap, ENVIRON proposes to begin pumping some of the new wells, which is described in more detail in the following sections.

As expected, the current estimated capture zones at IWF and AWF are very similar to those presented in the 2010 CZE Report, due to the fact that average pumping rates have remained relatively constant for the last five years.

As described in the remainder of this appendix, ENVIRON is proposing to adjust the pumping rates at both well fields including the commencement of pumping at several wells that were installed by Tronox in June 2010, but have not yet been used for extraction.

4. Analysis of Mass Removal

4.1 Historical Extraction Rates and Mass Removals

To evaluate alternatives for effective operation and to enhance the performance of the GWETS, historical perchlorate and chromium mass removal estimates were calculated for each well using available extraction rates and perchlorate and chromium concentration data for the time period July 1, 2002 to June 30, 2012.

The mass removal estimates were calculated using daily extraction rates and available (generally monthly) analytical results for perchlorate and chromium. Linear interpolation was used to estimate daily concentrations allowing calculation of daily mass removals. Daily chromium and perchlorate mass removal results were then summed for each fiscal year from 2002/2003 to 2011/2012 and plots were generated with the software package MATLAB 7.8.0.

For calculation of the mass estimates, non-detect values were substituted with half the reporting limit. For the two pairs of wells that share a pump (ART-6/ART-9 and PC-99R2/99R3), the concentration data for the two wells were averaged for each day, if available. Otherwise, the concentration from the well having data for that day was used. Likewise for all other wells, any duplicate data reported on the same day, such as from field duplicate samples, were averaged.

Historical extraction rates and mass removal plots for perchlorate and chromium for each well in the IWF and AWF are provided in Attachments F-1 and F-2, respectively. Historical extraction rates and mass removal plots for perchlorate only for each well in the SWF are provided in Attachment F-3. The SWF mass removal plots are provided only for comparison as the analysis described herein is focused on the IWF and AWF only.

4.2 Mass Removal at IWF

Table F-1A contains well construction details for the IWF wells. Figure F-5 presents the current (Second Quarterly 2012) extraction rates, perchlorate concentrations, and mass removals for the IWF wells. An equivalent figure showing chromium concentrations and mass removals in individual IWF wells is included as Figure F-6. Attachment F-1 presents the historical extraction rates and mass removal plots for perchlorate and chromium for each well in the IWF.

The annual average perchlorate mass removal at the IWF has declined to 601 pounds/day in 2011-12 from 1,043 pounds/day in 2002-03. Overall, mass removed at the IWF is approximately 50% of the total mass removed by the three well fields. The historical concentration plots for each IWF well in Attachment F-1 further show that the perchlorate concentration is declining over time. There is a significant decline at well I-AR where the concentration declined from 12,000 mg/L to 2,200 mg/L in the last nine years of operation. The total mass removal at the IWF has been stable since approximately 2007.

As shown on Figure F-5, well I-Z is the highest capacity well at the IWF which is currently extracting at a rate of 6.7 gpm. The corresponding perchlorate concentration at this well is 310 mg/L. In contrast, wells such as I-A-R extract at a much lower rate (1.0 gpm), but achieve relatively high mass removal due to high perchlorate concentrations (2,200 mg/L). There are other wells (I-Y, I-W and I-X) which are not operating, but located in an area of relatively high

perchlorate concentration. In addition, there are non-operating wells located outside of the current capture zone that could be activated to extend the capture zone laterally. Comparing Figures F-5 and F-6 demonstrates only one significant difference between the lateral distribution of perchlorate and chromium at the IWF: the high concentrations of perchlorate on the west side of the IWF (centered around well I-A-R) are not associated with elevated concentrations of chromium as is the case further east within the IWF where high concentrations of both perchlorate and chromium are centered around well I-U.

4.3 Mass Removal at AWF

Table F-1B contains well construction details for the AWF wells. Figure F-7 presents the current (Second Quarter 2012) extraction rates, perchlorate concentrations, and mass removals for the AWF wells. An equivalent figure showing chromium concentrations and mass removals in individual AWF wells is included as Figure F-8. Attachment F-2 presents the historical extraction rates and mass removal plots for perchlorate and chromium for each well in the AWF.

The AWF annual average perchlorate mass removal has declined to 553 pounds/day in from July 2011-June 2012 from approximately 800 pounds/day in 2004-05. Historical concentration plots in Attachment F-2 show that the decline in perchlorate mass removal at the AWF is due primarily to perchlorate concentrations decreasing at AWF wells over time. There is a significant decline at well ART-2 where the concentration declined from approximately 400 mg/L to 50 mg/L in the last nine years of operation. Total perchlorate mass removal at the AWF has been stable since about 2009. The perchlorate mass removed by the AWF is approximately 46% of the total mass removed by the GWETS.

As shown on Figure F-7, the wells ART-1 and ART-2 have relatively low mass removal rates, but high pumping rates as compared to other wells in the AWF. In contrast, well ART-4 has a relatively low mass removal rate even though it is in an area of high perchlorate concentration due to the low extraction rate exhibited in this well. There are other wells (ART-7B and PC-150), which are not operating but are located in an area of relatively high perchlorate concentration. Moreover, PC-150 is located outside of the current capture zone and could be activated to enhance mass capture and address the capture gap discussed previously. There are not significant differences in the perchlorate and chromium distributions based on Figures F-7 and F-8.

5. Recommendations

The objective of this preliminary analysis is to maximize efficiency of the IWF and AWF by identifying alternative extraction rates for existing wells and target extraction rates for new wells that in combination are expected to enhance mass capture. ENVIRON believes that the operational adjustments recommended below will serve as a first step in increasing the capture efficiency of these two well fields.

5.1 Proposed Changes to IWF Extraction Rates

The proposed extraction rates for each well in the IWF and expected mass removal rates are shown in Table F-2. Since the new extraction wells are not routinely sampled, the perchlorate and chromium concentrations at these wells are interpolated from the isoconcentration maps from second quarter 2012 (Plates 6 and 7 of the annual report). The extraction rates are proposed to be adjusted on the basis of mass removal while also considering the maximum sustainable flow rates for each extraction well that have been established based on historical operations of the wells, results of the IWF rehabilitation project undertaken by Tronox in 2007-2008, and professional judgment. The combined extraction rate for the IWF is proposed to increase, but as discussed in Section 2.2, is limited to 75 gpm due to the hydraulic limitations of the GWTP. Furthermore, until testing can be performed it is unclear whether this proposed combined extraction rate is sustainable given current hydrogeologic conditions.

Extraction rates in wells I-G, I-Q and I-U (currently at 0.1 gpm, 0.3 gpm and 0.7 gpm, respectively) are proposed to be increased to 0.5 gpm, 2.5 gpm and 0.8 gpm, respectively. The pumping in wells I-K, I-S and I-J is proposed to decrease to 2.0 gpm, 5.0 gpm and 2.5 gpm respectively. The pumping in well I-Z is proposed to decrease from 6.7 gpm to 5.5 gpm.

It is recommended that extraction from seven new wells in the IWF be initiated. Wells I-W, I-X, and I-Y are targeted to pump at 2.5, 2.5, and 4.1 gpm, respectively, with wells located at the edges of the IWF (I-AA, I-AB, I-AC and I-AD) assigned a target pumping rate of 1.0 gpm. The actual sustainable extraction rates of the new wells would be determined following shakedown and pump testing. Effects on capture would be evaluated using the groundwater flow model. With the proposed pumping rates, ENVIRON estimates that perchlorate mass removal at the IWF would increase from approximately 695 pounds/day to 851 pounds/day (Figure F-9). The chromium mass removal is estimated to increase from 6.64 pounds/day to 8.54 pounds/day (Figure F-10).

5.2 Proposed Changes to AWF Extraction Rates

Proposed extraction rates for each well in the AWF and expected mass removal rates are shown in Table F-3. The perchlorate concentration at new extraction wells is inferred as discussed in Section 4.2. The extraction rates are proposed to be adjusted on the basis of mass removal while also considering the maximum sustainable flow rates for each extraction well, which have been established based on historical operations of the wells. The combined extraction rate for the AWF is proposed to increase, but as discussed in Section 2.2, is limited to 290 gpm due to the hydraulic limitations of Lift Station 3. Furthermore, until testing can be performed it is unclear whether this increased combined extraction rate is sustainable given current hydrogeologic conditions.

Extraction rates in wells ART-3 and ART-8 (currently at 46.1 gpm and 62.7 gpm) are proposed to increase to 52.5 gpm, and 85.0 gpm, respectively. To minimize the dewatering of the Shallow Zone and to accommodate increased pumping, it is further proposed to decrease pumping in well ART-1 from 14.1 gpm to 1.0 gpm. The pumping rate for wells ART-2 and ART-9 are not proposed to change significantly.

New extraction wells ART-7B and PC-150 are proposed to be placed into active operation and pumped at their maximum capacities. For the purpose of estimating mass removal, extraction rates of 31.0 gpm and 5.0 gpm have been selected as reasonably achievable extraction rates for ART-7B and PC-150, respectively, based on professional judgment. The actual sustainable extraction rates of the new wells would be determined following shakedown and pump testing. It is expected that the proposed extraction from ART-7B would replace ART-7, since the wells are collocated; therefore, for this analysis it is assumed that the extraction rate for ART-7 would be zero under the proposed scenario. Effects on capture using the proposed rates would be evaluated in a future study using the groundwater flow model. The wells located within the area of unsaturated alluvium, PC-148 and PC-149, are not proposed for pumping at this time due to concerns that they will not yield significant water; however, if future capture zone analyses suggest additional pumping is necessary at this location, pumping could be attempted. ENVIRON estimates that perchlorate mass removal at the AWF would increase from approximately 667 pounds/day to 801 pounds/day (Figure F-9) upon implementation of the operational changes proposed above. The chromium mass removal rate is expected to increase from 1.38 pounds/day to 1.64 pounds/day at the AWF with the proposed extraction rates (Figure F-10).

5.3 Startup and Testing of New Wells

The adjusted extraction rates presented in Tables F-2 and F-3 will require the startup of nine new extraction wells: I-AA, I-AB, I-AC, I-AD, I-X, I-Y, and I-Z at the IWF and ART-7B and PC-150 at the AWF. The seven new IWF wells have already been connected to the GWETS; however, shakedown testing of these wells would be necessary to confirm they are in proper working order. The two new wells at the AWF would need to be plumbed and wired before startup and testing could commence. However, since PC-150 is located within the secured area of Lift Station 3, it is expected that the initial pumping and testing of this well could be performed with temporary lines to evaluate its performance prior to trenching and installation of permanent lines.

As additional wells are brought online, it would be necessary to perform testing of each of the new wells to evaluate its performance and effect on nearby wells. The well testing, the specifics of which would be described in a subsequent work plan, would be used to evaluate the extraction rates proposed herein and to determine the spatial effects of pumping on the aquifer and effects on the capture zone. This testing would be coordinated with the analyses performed using the groundwater flow model to provide multiple lines of evidence of capture.

Furthermore, as this work would require NDEP approval and coordination among numerous entities, including the operators and maintenance providers for the GWETS and the City of Henderson (owners of the property on which the AWF is situated), a work plan would be

prepared describing the steps for construction, startup, and testing of the new extraction wells. The work plan would also describe risk management measures, methods of managing soil and groundwater generated during construction, and procedures to minimize disturbance to active groundwater remediation in accordance with the Site Management Plan developed for the Site (ENVIRON 2012).

5.4 Capture Zone Analysis Using the Groundwater Model

A more detailed evaluation of the effect of the operational changes proposed in this appendix on the capture zones of the IWF and AWF systems would be conducted using the groundwater flow model once the model has been approved by NDEP.

6. References

- ENVIRON International Corporation. 2012. Annual Remedial Performance Report for Chromium and Perchlorate, Nevada Environmental Response Trust Site, Henderson, Nevada July 2011 – June 2012. August 31.
- ENVIRON International Corporation. 2011a. Annual Remedial Performance Report for Chromium and Perchlorate, Nevada Environmental Response Trust Site, Henderson, Nevada July 2010 – June 2011. August 26.
- ENVIRON International Corporation. 2012. Site Management Plan (SMP) Nevada Environmental Response Trust Site, Clark County, Nevada. April.
- Karanovic, M., Tonkin, M., and Wilson, D. 2009. *KT3D_H2O*: A Program for Kriging Water Level Data Using Hydrologic Drift Terms. *Ground Water*, Vol. 47, NO. 4:580-586.
- Northgate Environmental Management, Inc., 2010a. Capture Zone Evaluation Report, Tronox LLC. Henderson, Nevada. December 10.
- Northgate Environmental Management, Inc. 2010b. Interim Groundwater Capture Evaluation and Vertical Delineation Report, Tronox LLC, Henderson, Nevada. March 23.

Tables

TABLE : -1A: INTERCEPTOR WELL CONSTRUCTION DETAILS

Nevada Environmental Response Trust Site
Henderson, Nevada

| Well ID | Muddy Creek Elevation (ft amsl) | Depth to Qal/UMCf Contact (feet) | Total Borehole Depth (ft bgs) | Well Total Depth (ft bgs) | Depth to Top of Screen (feet bgs) | Depth to Bottom of Screen (feet bgs) | Screen Interval (feet) | Installation Date | Casing Material | Casing Diameter (inches) | Filter Interval (feet) | Screen Size | Water-Bearing Zone | Lithology |
|---------|---------------------------------|----------------------------------|-------------------------------|---------------------------|-----------------------------------|--------------------------------------|------------------------|-------------------|-----------------|--------------------------|------------------------|-------------|--------------------|---------------|
| I-B | 1723.0 | 27.0 | 46.0 | 43.0 | 17.8 | 42.5 | 24.7 | 10/1/1986 | PVC | 6 | 14.3-46 | 0.02 | Shallow | Qal/xMCf/UMCf |
| I-C | 1724.5 | 27.5 | 44.5 | 43.0 | 13.2 | 42.5 | 29.3 | 12/1/1986 | PVC | 6 | 10.4-44.5 | 0.02 | Shallow | UMCf |
| I-D | 1721.0 | 29.0 | 47.0 | 45.0 | 16.0 | 44.5 | 28.5 | 10/1/1986 | PVC | 6 | 10.7-47 | 0.02 | Shallow | Qal/xMCf/UMCf |
| I-E | 1723.0 | 27.0 | 49.0 | 44.0 | 21.5 | 43.5 | 22 | 12/1/1986 | PVC | 6 | 10.2-49 | 0.02 | Shallow | UMCf |
| I-F | 1717.7 | 30.0 | 50.0 | 43.8 | 11.8 | 43.3 | 31.5 | 9/1/1986 | PVC | 6 | 11-50 | 0.02 | Shallow | Qal/xMCf/UMCf |
| I-G | 1721.2 | 28.0 | 43.5 | 39.3 | 9.5 | 38.8 | 29.3 | 12/1/1986 | PVC | 6 | 7-43.5 | 0.02 | Shallow | Qal/xMCf/UMCf |
| I-H | 1721.8 | 28.5 | 47.0 | 43.6 | 13.6 | 43.1 | 29.5 | 9/1/1986 | PVC | 6 | 11.6-47 | 0.02 | Shallow | UMCf |
| I-I | 1715.8 | 26.5 | 45.0 | 41.0 | 11.3 | 40.5 | 29.2 | 12/1/1986 | PVC | 6 | 8.5-45 | 0.02 | Shallow | Qal/xMCf/UMCf |
| I-J | 1718.6 | 28.0 | 45.0 | 41.0 | 11.2 | 40.5 | 29.3 | 12/1/1986 | PVC | 6 | 8.7-45 | 0.02 | Shallow | Qal/xMCf/UMCf |
| I-K | 1719.3 | 24.5 | 43.0 | 35.8 | 7.0 | 35.2 | 28.2 | 12/1/1986 | PVC | 6 | 6-43 | 0.02 | Shallow | UMCf |
| I-L | 1720.3 | 28.0 | 45.0 | 40.0 | 9.0 | 39.0 | 30 | 10/1/1993 | PVC | 6 | 7-45 | 0.02 | Shallow | Qal/xMCf/UMCf |
| I-M | 1719.2 | 30.0 | 45.0 | 40.0 | 9.0 | 39.0 | 30 | 10/1/1993 | PVC | 6 | 7-40 | 0.02 | Shallow | Qal/xMCf/UMCf |
| I-N | 1713.8 | 34.0 | 45.0 | 38.0 | 7.0 | 37.0 | 30 | 10/1/1993 | PVC | 6 | 5-38 | 0.02 | Shallow | Qal/xMCf/UMCf |
| I-O | 1719.0 | 30.0 | 40.0 | 40.0 | 9.0 | 39.0 | 30 | 10/1/1993 | PVC | 6 | 7-40 | 0.02 | Shallow | Qal/xMCf/UMCf |
| I-P | 1716.2 | 33.0 | 45.0 | 44.5 | 14.0 | 44.0 | 30 | 3/1/1998 | PVC | 6 | 12-45 | 0.02 | Shallow | Qal/xMCf/UMCf |
| I-Q | 1721.4 | 28.0 | 40.0 | 40.0 | 9.6 | 39.6 | 30 | 3/1/1998 | PVC | 6 | 7-40 | 0.02 | Shallow | Qal/xMCf/UMCf |
| I-R | 1721.6 | 27.5 | 45.0 | 43.0 | 9.8 | 39.8 | 30 | 2/1/1999 | PVC | 6 | 7.8-43 | 0.02 | Shallow | Qal/xMCf/UMCf |
| I-S | 1721.1 | 26.5 | 45.2 | 45.2 | 12.0 | 42.0 | 30 | 2/1/1999 | PVC | 6 | 9.5-45.2 | 0.02 | Shallow | Qal/xMCf/UMCf |
| I-T | 1718.0 | 31.0 | 60.0 | 45.2 | 12.0 | 42.0 | 30 | 2/1/1999 | PVC | 6 | 10-45.2 | 0.02 | Shallow | Qal/xMCf/UMCf |
| I-U | 1721.0 | 28.5 | 45.0 | 45.0 | 12.0 | 42.0 | 30 | 2/1/1999 | PVC | 6 | 9.5-45 | 0.02 | Shallow | Qal/xMCf/UMCf |
| I-V | 1717.0 | 32.5 | 55.0 | 45.0 | 12.0 | 42.0 | 30 | 2/1/1999 | PVC | 6 | 9.5-45 | 0.02 | Shallow | Qal/xMCf/UMCf |
| I-W | 1727.1 | 33.0 | 51.0 | 50.5 | 20.0 | 50.0 | 30 | 9/1/2000 | PVC | 6 | 14-51 | 0.02 | Shallow | Qal/xMCf/UMCf |
| I-X | 1713.2 | 33.0 | 51.0 | 50.5 | 20.0 | 50.0 | 30 | 9/1/2000 | PVC | 6 | 14-51 | 0.02 | Shallow | Qal/xMCf/UMCf |
| I-Y | 1720.9 | 28.0 | 50.5 | 50.5 | 20.0 | 50.0 | 30 | 9/1/2000 | PVC | 6 | 14-50.5 | 0.02 | Shallow | Qal/xMCf/UMCf |
| I-Z | 1718.8 | 25.0 | 40.0 | 35.0 | 15.0 | 35.0 | 20 | 6/1/2003 | PVC | 6 | 10-35 | 0.02 | Shallow | Qal/xMCf/UMCf |
| I-AA | 1721.1 | 30.0 | 47.0 | 46.0 | 23.7 | 43.7 | 20 | 12/4/2007 | PVC | 6 | 18-47 | 0.02 | Shallow | UMCf |
| I-AB | 1723.4 | 30.5 | 51.0 | 51.0 | 25.0 | 45.0 | 20 | 8/14/2009 | PVC | 6 | 20-51 | 0.02 | Shallow | Qal/UMCf |
| I-AC | 1717.1 | 33.0 | 50.0 | 50.0 | 24.5 | 44.5 | 20 | 6/15/2010 | PVC | 6 | 20-50 | 0.02 | Shallow | Qal/UMCf |
| I-AD | 1721.9 | 31.0 | 50.0 | 50.0 | 24.5 | 44.5 | 20 | 6/16/2010 | PVC | 6 | 20-50 | 0.02 | Shallow | Qal/UMCf |
| I-A-R | 1731.0 | 27.0 | 45.0 | 45.0 | 25.0 | 45.0 | 20 | 4/1/2000 | Galv Steel | 18 | 20-45 | 0.02 | Shallow | UMCf |

Notes:

Qal = Alluvium

xMC = Transition Zone between Alluvium and Muddy Creek Formation

UMCf = Upper Muddy Creek Formation

TABLE : -1B: ATHENS ROAD WELL CONSTRUCTION DETAILS

Nevada Environmental Response Trust Site

Henderson, Nevada

| Well ID | Muddy Creek Elevation (ft amsl) | Depth to Qal/UMCf Contact (feet) | Total Borehole Depth (ft bgs) | Well Total Depth (ft bgs) | Depth to Top of Screen (feet bgs) | Depth to Bottom of Screen (feet bgs) | Screen Interval (feet) | Installation Date | Casing Material | Casing Diameter (inches) | Filter Interval (feet) | Screen Size | Water-Bearing Zone | Lithology |
|---------|---------------------------------|----------------------------------|-------------------------------|---------------------------|-----------------------------------|--------------------------------------|------------------------|-------------------|-----------------|--------------------------|------------------------|-------------|--------------------|-----------|
| ART-1 | 1562.6 | 53.0 | 58.0 | 56.0 | 14.0 | 54.0 | 40 | 10/1/2001 | PVC/SS | 6 | 11-58 | 0.04 | Shallow | Qal |
| ART-1A | 1561.8 | 54.0 | 58.0 | 56.0 | 19.0 | 54.0 | 35 | 3/1/2003 | PVC/SS | 8 | 16-57 | 0.04 | Shallow | Qal |
| ART-2 | 1562.4 | 55.0 | 57.0 | 56.0 | 19.0 | 54.0 | 35 | 10/1/2001 | PVC/SS | 6 | 16-57 | 0.04 | Shallow | Qal |
| ART-2A | 1561.3 | 57.0 | 58.0 | 58.0 | 21.0 | 56.0 | 35 | 3/1/2003 | PVC/SS | 8 | 9-58 | 0.04 | Shallow | Qal |
| ART-3 | NR | NR | 48.5 | 47.0 | 15.0 | 45.0 | 30 | 10/1/2001 | PVC/SS | 6 | 13-48.5 | 0.04 | Shallow | Qal |
| ART-3A | 1566.1 | 53.0 | 58.0 | 55.0 | 18.0 | 53.0 | 35 | 3/1/2003 | PVC/SS | 8 | 9-58 | 0.04 | Shallow | Qal |
| ART-4 | 1573.9 | 44.4 | 48.4 | 46.4 | 19.4 | 44.4 | 25 | 10/1/2001 | PVC/SS | 6 | 14.4-48.4 | 0.02 | Shallow | Qal |
| ART-4A | 1574.9 | 43.4 | 47.4 | 45.4 | 18.4 | 43.4 | 25 | 2/1/2003 | PVC/SS | 8 | 7.4-45.4 | 0.04 | Shallow | Qal |
| ART-5 | 1589.2 | 28.6 | 31.6 | 30.6 | 18.6 | 28.6 | 10 | 10/1/2001 | PVC/SS | 6 | 15.6-30.6 | 0.04 | Shallow | Qal |
| ART-6 | 1582.3 | 37.9 | 41.9 | 39.9 | 17.9 | 37.9 | 20 | 10/1/2001 | PVC/SS | 6 | 13.5-39.9 | 0.04 | Shallow | Qal |
| ART-6A | 1582.3 | 37.7 | 41.7 | 39.7 | 22.7 | 37.7 | 15 | 3/1/2003 | PVC/SS | 8 | 10.7-39.7 | 0.04 | Shallow | Qal |
| ART-7 | NR | NR | 41.7 | 41.0 | 19.0 | 39.0 | 20 | 10/1/2001 | PVC/SS | 6 | 13.5-41 | 0.04 | Shallow | Qal |
| ART-7A | NR | NR | 42.7 | 41.7 | 19.7 | 39.7 | 20 | 3/1/2003 | PVC/SS | 8 | 9.7-41.7 | 0.04 | Shallow | Qal |
| ART-7B | 1573.1 | 45.0 | 50.0 | 50.0 | 29.5 | 44.5 | 15 | 6/28/2010 | PVC/SS | 8 | 25-50 | 0.04 | Shallow | Qal |
| ART-8 | 1567.5 | 51.0 | 54.0 | 50.5 | 18.0 | 48.0 | 30 | 1/1/2002 | PVC/SS | 6 | 15-54 | 0.02 | Shallow | Qal |
| ART-8A | 1566.5 | 52.0 | 58.0 | 54.0 | 22.0 | 52.0 | 30 | 3/1/2003 | PVC/SS | 8 | 9-58 | 0.04 | Shallow | Qal |
| ART-9 | 1576.2 | 42.5 | 47.5 | 45.5 | 23.0 | 43.0 | 20 | 5/1/2006 | PVC/SS | 8 | 15-45.5 | 0.04 | Shallow | Qal |
| PC-148 | 1592.8 | 25.0 | 50.0 | 50.0 | 24.5 | 44.5 | 20 | 6/19/2010 | PVC | 6 | 20-50 | 0.01 | Shallow | UMCf |
| PC-149 | 1586.9 | 32.0 | 50.0 | 50.0 | 24.5 | 44.5 | 20 | 6/23/2010 | PVC | 6 | 20-50 | 0.01 | Shallow | Qal/UMCf |
| PC-150 | 1579.4 | 39.0 | 45.0 | 45.0 | 19.5 | 39.5 | 20 | 6/30/2010 | PVC | 6 | 15-45 | 0.02 | Shallow | Qal |

Notes:

Qal = Alluvium

xMCf = Transition Zone between Alluvium and Muddy Creek Formation

UMCf = Upper Muddy Creek Formation

TABLE : -2: CURRENT AND PROPOSED MASS REMOVAL AT THE INTERCEPTOR WELL FIELD

Nevada Environmental Response Trust Site

Henderson, Nevada

| Well | Perchlorate Concentration (mg/L) | Total Chromium Concentration (mg/L) | Current Extraction Rate (gpm) | Current Perchlorate Mass Removal (pounds/day) | Current Total Chromium Mass Removal (pounds/day) | Maximum Sustainable Flow (gpm) | Proposed Extraction Rate (gpm) | Expected Perchlorate Mass Removal (pounds/day) | Expected Total Chromium Mass Removal (pounds/day) |
|-----------------------|----------------------------------|-------------------------------------|-------------------------------|---|--|--------------------------------|--------------------------------|--|---|
| Existing Wells | | | | | | | | | |
| I-A-R | 2200 | 1.4 | 1.1 | 29.1 | 0.02 | 1.0 | 1.0 | 26.4 | 0.02 |
| I-B | 480 | 1.0 | 1.5 | 8.7 | 0.02 | 1.5 | 1.5 | 8.7 | 0.02 |
| I-C | 860 | 3.1 | 5.9 | 61.0 | 0.22 | 6.0 | 6.0 | 62.0 | 0.22 |
| I-D | 730 | 7.4 | 1.3 | 11.4 | 0.12 | 2.0 | 1.5 | 13.2 | 0.13 |
| I-E | 710 | 10.0 | 1.3 | 11.1 | 0.16 | 1.5 | 1.5 | 12.8 | 0.18 |
| I-F | 1200 | 19.0 | 5.7 | 82.2 | 1.30 | 5.7 | 5.7 | 82.2 | 1.30 |
| I-G | 1600 | 27.0 | 0.1 | 1.9 | 0.03 | 0.5 | 0.5 | 9.6 | 0.16 |
| I-H | 1600 | 26.0 | 0.9 | 17.3 | 0.28 | 1.2 | 1.2 | 23.1 | 0.37 |
| I-I | 720 | 13.0 | 5.0 | 43.3 | 0.78 | 5.0 | 4.4 | 38.1 | 0.69 |
| I-J | 250 | 2.9 | 6.3 | 18.9 | 0.22 | 8.0 | 2.5 | 7.5 | 0.09 |
| I-K | 120 | 1.3 | 3.9 | 5.6 | 0.06 | 4.0 | 2.0 | 2.9 | 0.03 |
| I-L | 1600 | 0.7 | 1.9 | 36.5 | 0.02 | 2.5 | 2.5 | 48.1 | 0.02 |
| I-M | 770 | 0.9 | 2.6 | 24.1 | 0.03 | 2.6 | 2.6 | 24.1 | 0.03 |
| I-N | 970 | 11.0 | 3.1 | 36.1 | 0.41 | 3.5 | 3.5 | 40.8 | 0.46 |
| I-O | 1600 | 22.0 | 1.7 | 32.7 | 0.45 | 2.5 | 2.5 | 48.1 | 0.66 |
| I-P | 1600 | 13.0 | 2.1 | 40.4 | 0.33 | 3.0 | 2.5 | 48.1 | 0.39 |
| I-Q | 1500 | 29.0 | 0.3 | 5.4 | 0.10 | 2.5 | 2.5 | 45.1 | 0.87 |
| I-R | 1600 | 0.4 | 2.5 | 48.1 | 0.01 | 2.5 | 2.3 | 43.3 | 0.01 |
| I-S | 870 | 1.4 | 5.2 | 54.4 | 0.09 | 5.0 | 5.0 | 52.3 | 0.08 |
| I-T | 1600 | 29.0 | 0.4 | 7.7 | 0.14 | 0.4 | 0.4 | 7.7 | 0.14 |
| I-U | 1600 | 27.0 | 0.7 | 13.5 | 0.23 | 0.8 | 0.8 | 15.4 | 0.26 |
| I-V | 1400 | 17.0 | 4.8 | 80.8 | 0.98 | 4.8 | 4.0 | 67.3 | 0.82 |
| I-Z | 310 | 8.1 | 6.7 | 25.0 | 0.65 | 8 | 5.5 | 20.5 | 0.54 |

TABLE : -2: CURRENT AND PROPOSED MASS REMOVAL AT THE INTERCEPTOR WELL FIELD

Nevada Environmental Response Trust Site

Henderson, Nevada

| Well | Perchlorate Concentration (mg/L) | Total Chromium Concentration (mg/L) | Current Extraction Rate (gpm) | Current Perchlorate Mass Removal (pounds/day) | Current Total Chromium Mass Removal (pounds/day) | Maximum Sustainable Flow (gpm) | Proposed Extraction Rate (gpm) | Expected Perchlorate Mass Removal (pounds/day) | Expected Total Chromium Mass Removal (pounds/day) |
|---|----------------------------------|-------------------------------------|-------------------------------|---|--|--------------------------------|--------------------------------|--|---|
| New Wells | | | | | | | | | |
| I-AA | 100 | 0.1 | NO* | 0 | 0 | -- | 1.0 | 1.2 | 0.00 |
| I-AB | 250 | 0.2 | NO* | 0 | 0 | -- | 1.0 | 3.0 | 0.00 |
| I-AC | 50 | 0.9 | NO* | 0 | 0 | -- | 1.0 | 0.6 | 0.01 |
| I-AD | 70 | 0.9 | NO* | 0 | 0 | -- | 1.0 | 0.8 | 0.01 |
| I-W | 1200 | 20.0 | NO* | 0 | 0 | -- | 2.5 | 36.1 | 0.60 |
| I-X | 1100 | 13.0 | NO* | 0 | 0 | -- | 2.5 | 33.0 | 0.39 |
| I-Y | 600 | 0.5 | NO* | 0 | 0 | -- | 4.1 | 29.6 | 0.02 |
| Total Pumping at IWF (gpm) | | | 65.0 | | | | 75.0 | | |
| Total Mass Removal at IWF (pounds/day) | | | | 695.0 | 6.64 | | | 851.3 | 8.54 |

Notes:

Current analytical results and extraction rates are from Second Quarter 2012.

Total chromium and perchlorate concentrations for the new wells are based on interpolation of concentration data presented on Plate 6 and Plate 7, respectively, in the main report.

The perchlorate mass removal rate for the IWF in Table 6 of the main report is differ slightly because it is based on combined flow rates and a perchlorate concentration from all IWF wells inflowing to the GWETS on a weekly frequency.

-- = no data available

gpm = gallons per minute

NO* = not operational

mg/L = milligrams per liter

TABLE F-3: CURRENT AND PROPOSED MASS REMOVAL AT THE ATHENS ROAD WELL FIELD

Nevada Environmental Response Trust Site

Henderson, Nevada

| Well | Perchlorate Concentration (mg/L) | Total Chromium Concentration (mg/L) | Current Extraction Rate (gpm) | Current Perchlorate Mass Removal (pounds/day) | Current Total Chromium Mass Removal (pounds/day) | Maximum Sustainable Flow (gpm) | Proposed Extraction Rates (gpm) | Expected Perchlorate Mass Removal (pounds/day) | Expected Total Chromium Mass Removal (pounds/day) |
|---|----------------------------------|-------------------------------------|-------------------------------|---|--|--------------------------------|---------------------------------|--|---|
| Existing Wells | | | | | | | | | |
| ART-1 | 4.8 | 0.00096 | 14.1 | 0.8 | 0.00 | 33.0 | 1.0 | 0.1 | 0.00 |
| ART-2 | 64 | 0.026 | 62.4 | 48.0 | 0.02 | 71.0 | 61.0 | 46.9 | 0.02 |
| ART-3 | 300 | 0.37 | 46.1 | 166.3 | 0.21 | 54.0 | 52.5 | 189.3 | 0.23 |
| ART-4 | 410 | 0.57 | 8.5 | 42.0 | 0.06 | 10.0 | 8.5 | 41.9 | 0.06 |
| ART-5 ¹ | -- | -- | NO | 0.0 | 0.00 | 0.0 | 0.0 | 0.0 | 0.0 |
| ART-6 ² | 300 | 1.2 | NO | 0.0 | 0.00 | 0.0 | 0.0 | 0.0 | 0.00 |
| ART-7 | 160 | 0.74 | 31.2 | 60.0 | 0.28 | 32.0 | 0.0 | 0.0 | 0.00 |
| ART-8 | 220 | 0.2 | 62.7 | 165.8 | 0.15 | 85.0 | 85.0 | 224.7 | 0.20 |
| ART-9 | 330 | 1.2 | 46.5 | 184.4 | 0.67 | 47.0 | 46.0 | 182.4 | 0.66 |
| New Wells | | | | | | | | | |
| ART-7B | 270 | 1.2 | NO* | 0.0 | 0.00 | -- | 31.0 | 100.6 | 0.45 |
| PC-148 | 32 | 0.027 | NO* | 0.0 | 0.00 | -- | 0.0 | 0.0 | 0.00 |
| PC-149 | 22 | 0.0061 | NO* | 0.0 | 0.00 | -- | 0.0 | 0.0 | 0.00 |
| PC-150 | 250 | 0.25 | NO* | 0.0 | 0.00 | -- | 5.0 | 15.0 | 0.02 |
| Total Pumping at AWF (gpm) | | | 271.6 | | | 332.0 | 290.0 | | |
| Total Mass Removal at AWF (pounds/day) | | | | 667.3 | 1.38 | | | 800.9 | 1.64 |

Notes:

Current analytical results and extraction rates are from Second Quarter 2012.

¹ ART-5 has been dry since February 2006

² Pumping from ART-6 was replaced by ART-9 in September 2006.

-- = no data available

NO = not operational

NO* = proposed pumping well

gpm = gallons per minute

mg/L = milligrams per liter

NA = not applicable

Figures

Path: H:\LePetomane\NERT\GWM\Annual Performance Reports\2012 Annual\Appendix E - Mass Removal Plots\Figures\Figure E1 - IWF_Capture_Zone_perchlorate.mxd

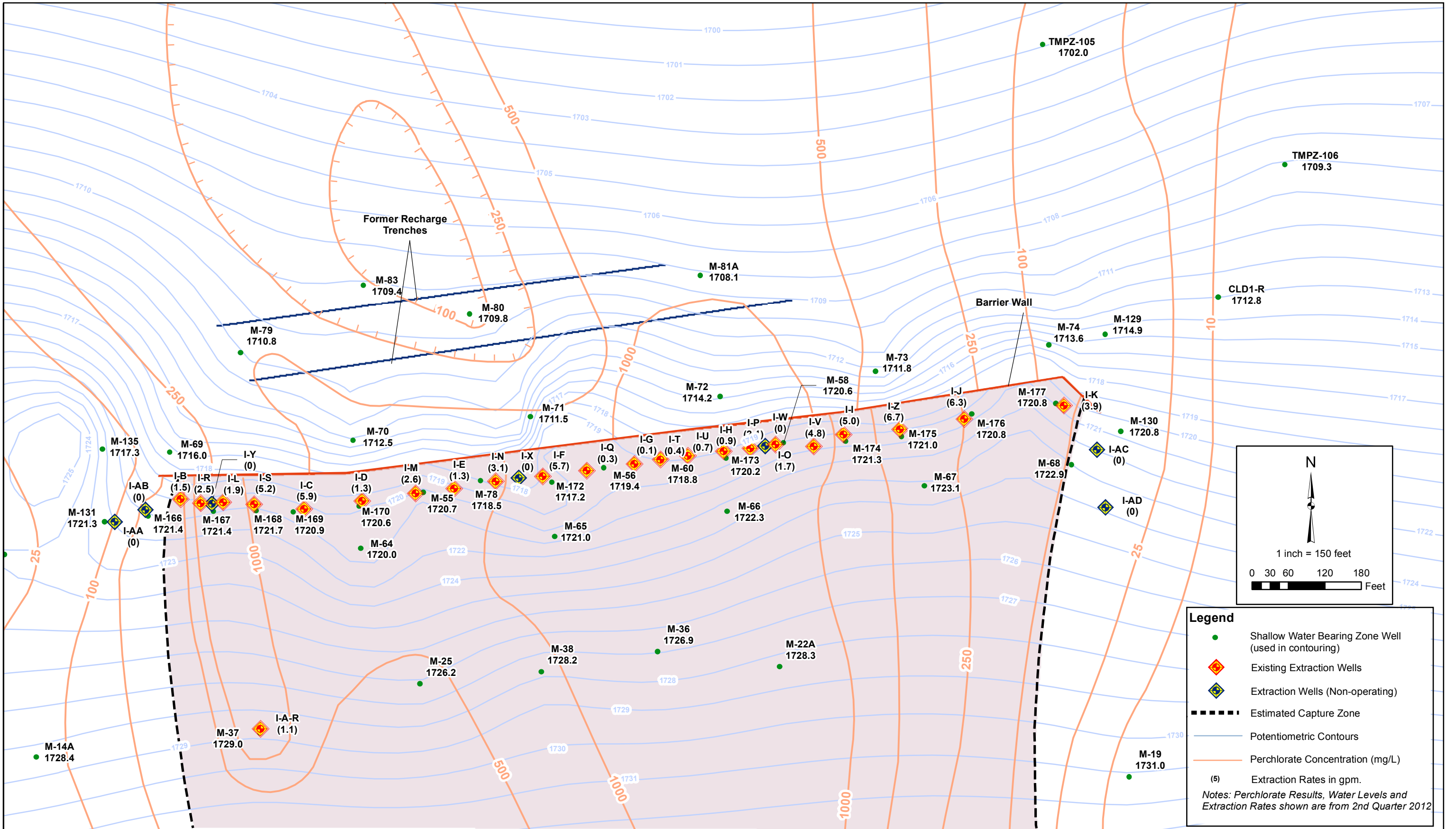

Interceptor Well Field Capture Zone and Perchlorate Concentrations
 Nevada Environmental Response Trust Site
 Henderson, Nevada

Figure
E-1

2200 Powell St., Suite 700, Emeryville, CA 94608

Drafter: EA

Date: 8/31/2012

Contract Number: 21-29100G

Approved by: AS

Revised: EA

Path: H:\LePetomane\NERT\GWM\Annual Performance Reports\2012 Annual\Appendix E - Mass Removal Plots\Figures\Figure E2 -IWF_Capture_Zone_Cr.mxd

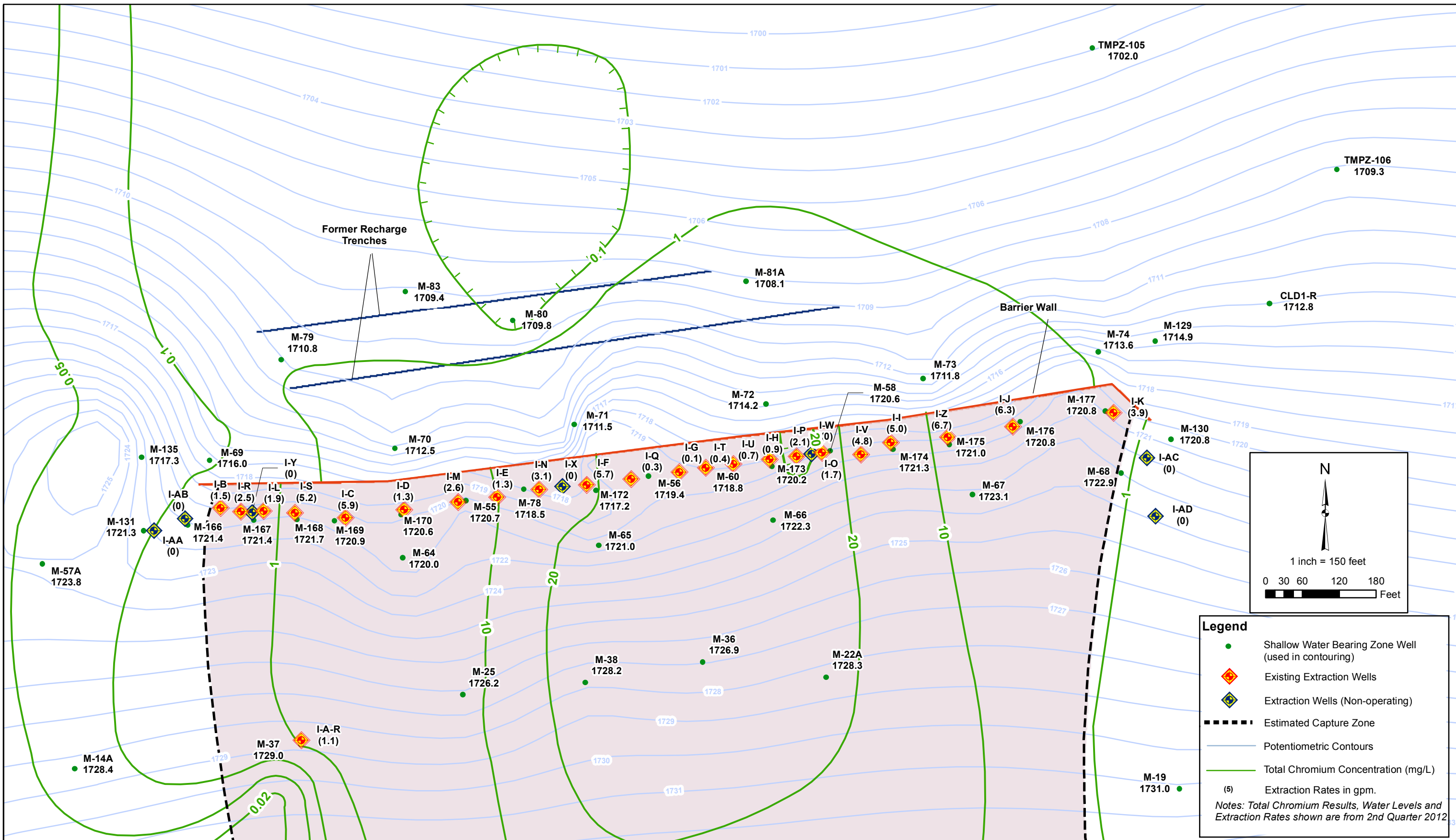

2200 Powell St., Suite 700, Emeryville, CA 94608

Interceptor Well Field Capture Zone and Total Chromium Concentrations
 Nevada Environmental Response Trust Site
 Henderson, Nevada

Drafter: EA

Date: 8/31/2012

Contract Number: 21-29100G

Approved by: AS

Revised: EA

Figure
E-2

Path: H:\LePetomane\NERT\GWM\Annual Performance Reports\2012 Annual\Appendix E - Mass Removal Plots\Figures\Figure E2 - Location Map_ARWF.mxd

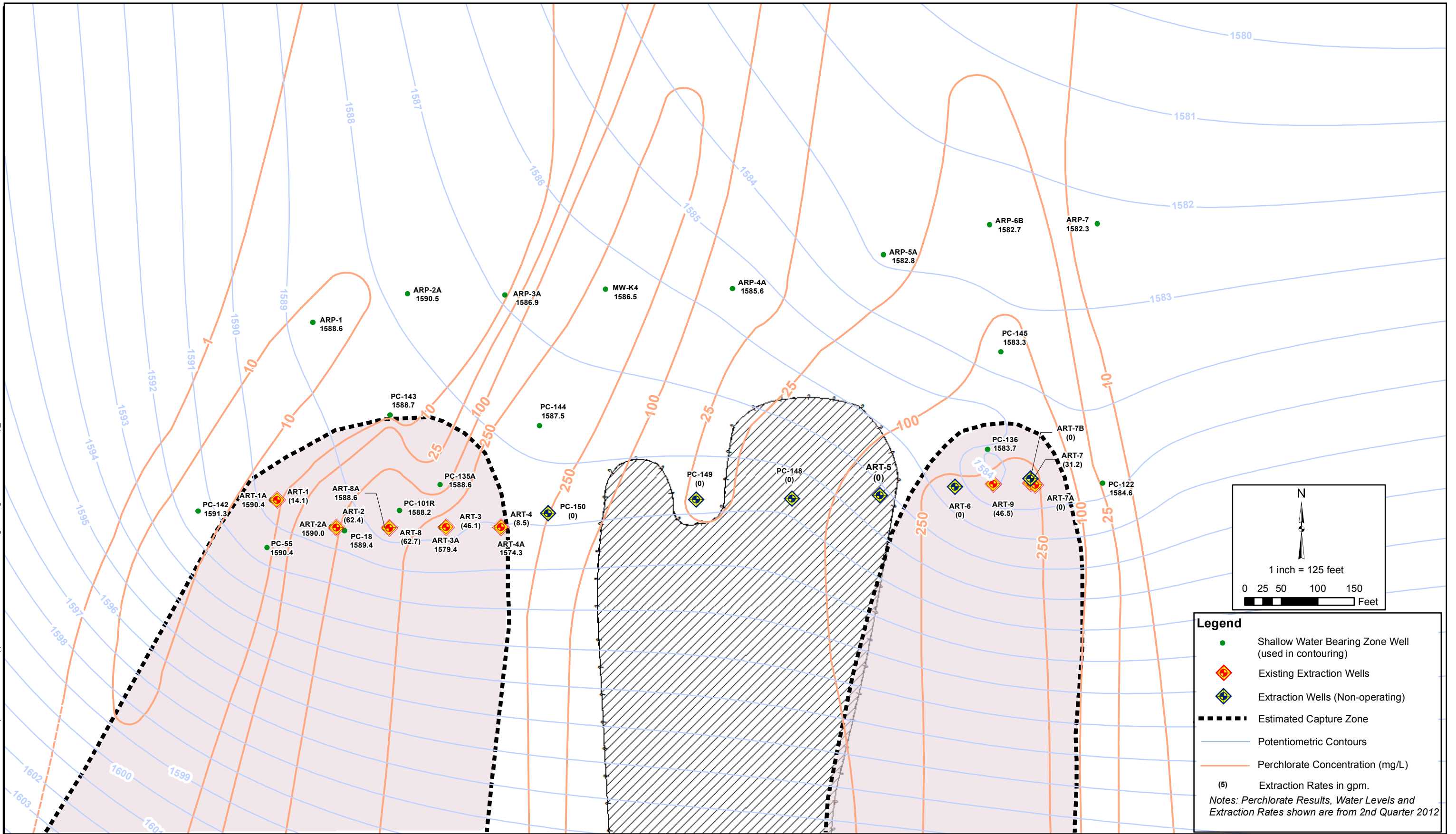

Legend

- Shallow Water Bearing Zone Well (used in contouring)
- ◆ Existing Extraction Wells
- ◆ Extraction Wells (Non-operating)
- Estimated Capture Zone
- Potentiometric Contours
- Perchlorate Concentration (mg/L)
- (5) Extraction Rates in gpm.

Notes: Perchlorate Results, Water Levels and Extraction Rates shown are from 2nd Quarter 2012



Athens Road Well Field Capture Zone and Perchlorate Concentrations
 Nevada Environmental Response Trust Site
 Henderson, Nevada

Figure
E-3

2200 Powell St., Suite 700, Emeryville, CA 94608

Drafter: EA

Date: 8/31/2012

Contract Number: 21-29100G

Approved by: AS

Revised: EA

Path: H:\LePetomane\NERT\GWA\Annual Performance Reports\2012 Annual\Appendix E - Mass Removal Plots\Figures\Figure E4 - Location Map_ARWF_cr.mxd

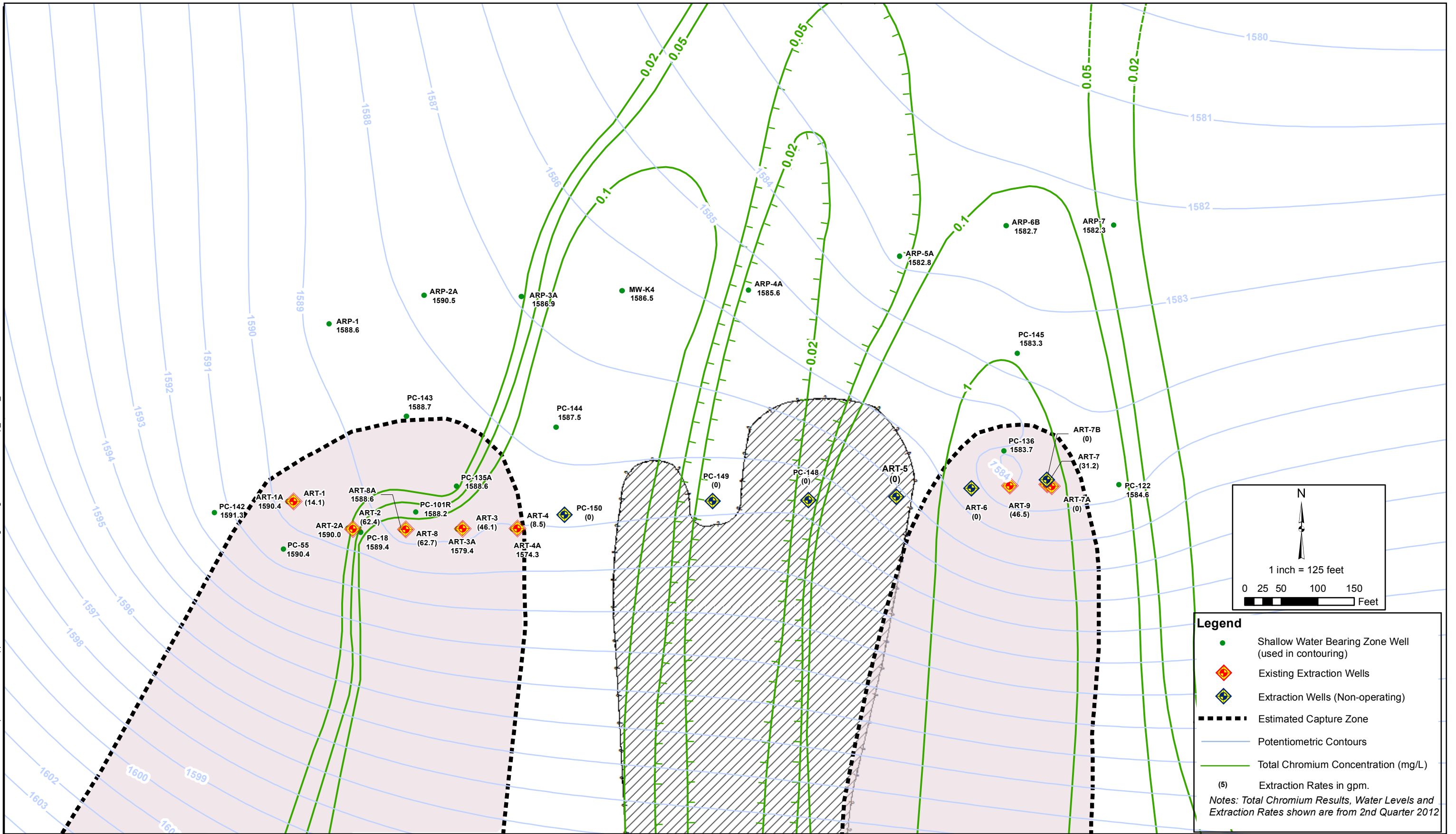

2200 Powell St., Suite 700, Emeryville, CA 94608

Athens Road Well Field Capture Zone and Total Chromium Concentrations
 Nevada Environmental Response Trust Site
 Henderson, Nevada

Drafter: EA

Date: 8/31/2012

Contract Number: 21-29100G

Approved by: AS

Revised: EA

Figure
E-4

Path: H:\LePetomane\NERT\GMM\Annual Performance Reports\2012 Annual\Appendix E - Mass Removal Plots\Figures\Figure E5 - Perchlorate removal\IWF.mxd

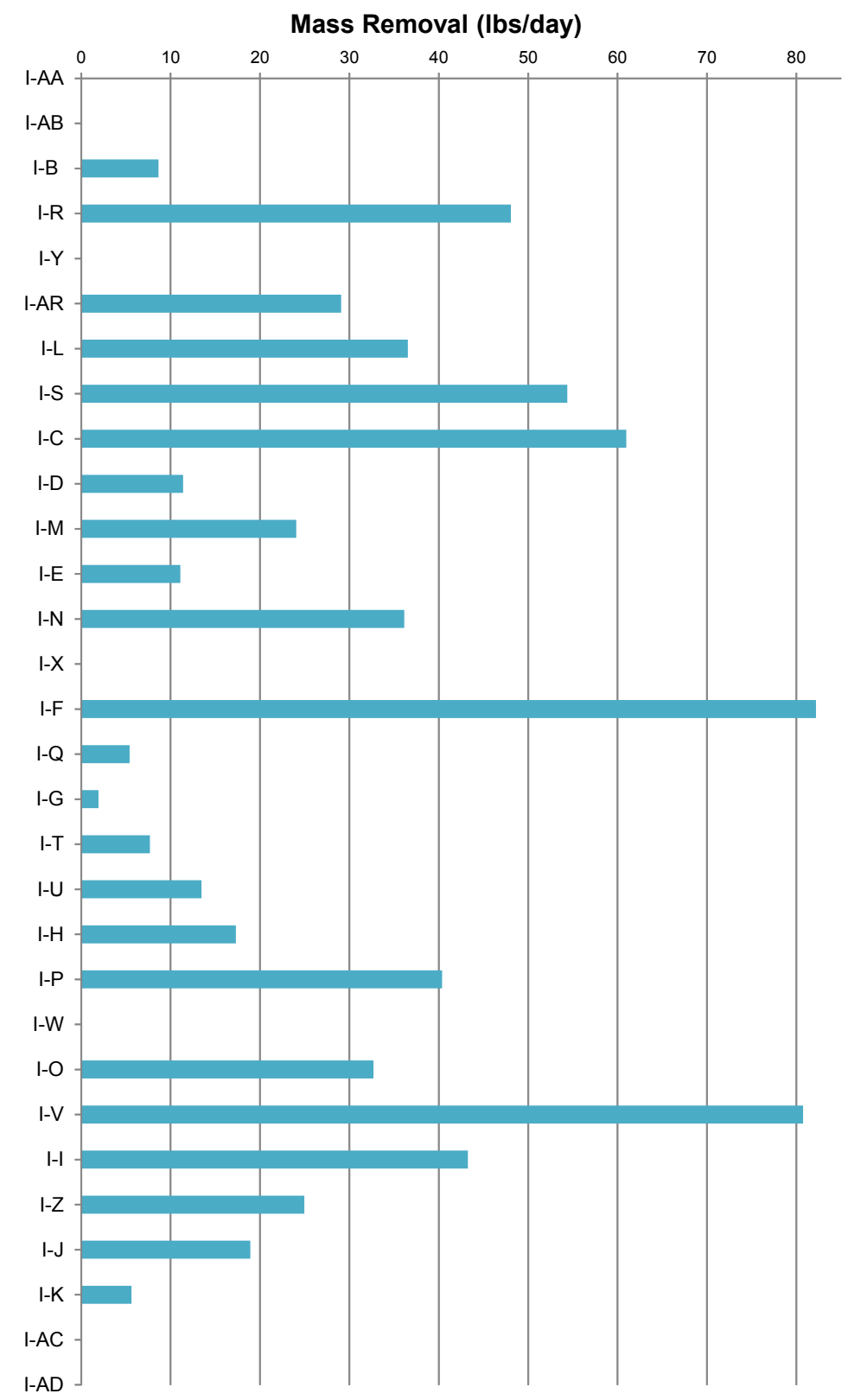
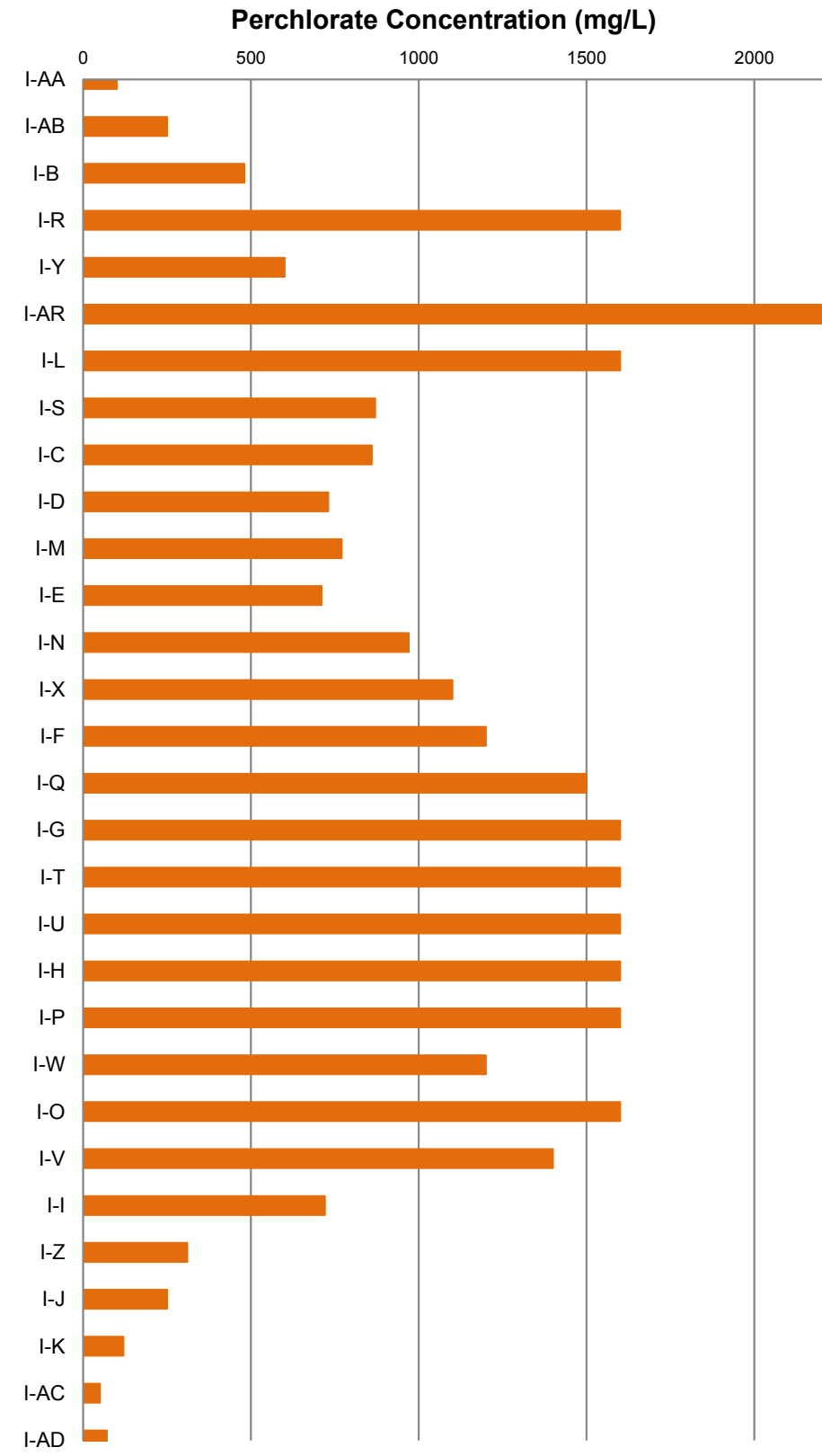
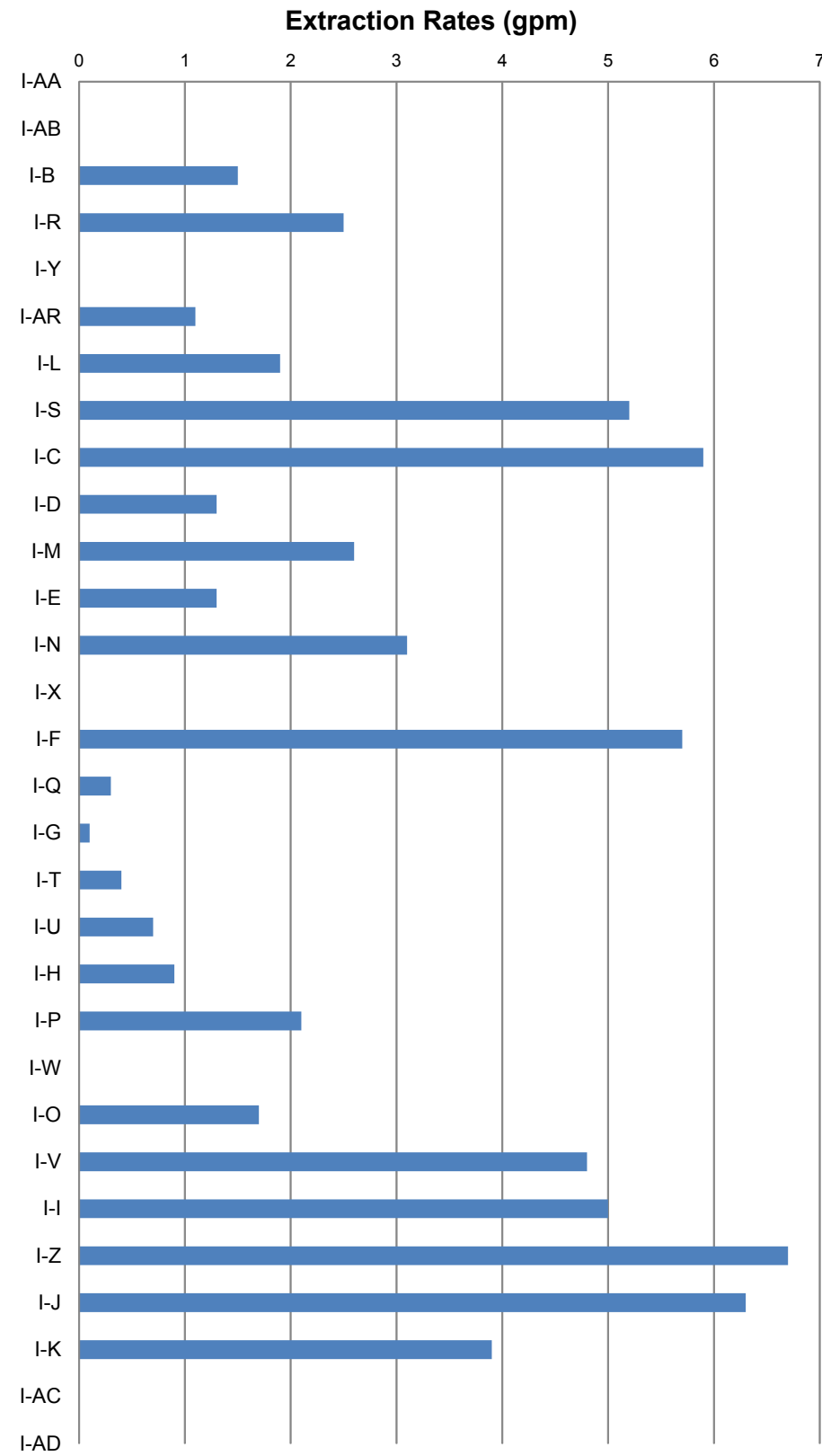

Current Perchlorate Removal at the Interceptor Well Field
 Nevada Environmental Response Trust Site
 Henderson, Nevada

Figure
E-5

Drafter: EA

Date: 8/31/2012

Contract Number: 21-29100G

Approved by: AS

Revised: EA

Path: H:\LePetomane\NERT\GWA\Annual Performance Reports\2012 Annual\Appendix E - Mass Removal\Plots\Figures\Figure E6 - Chromium removal\WF.mxd

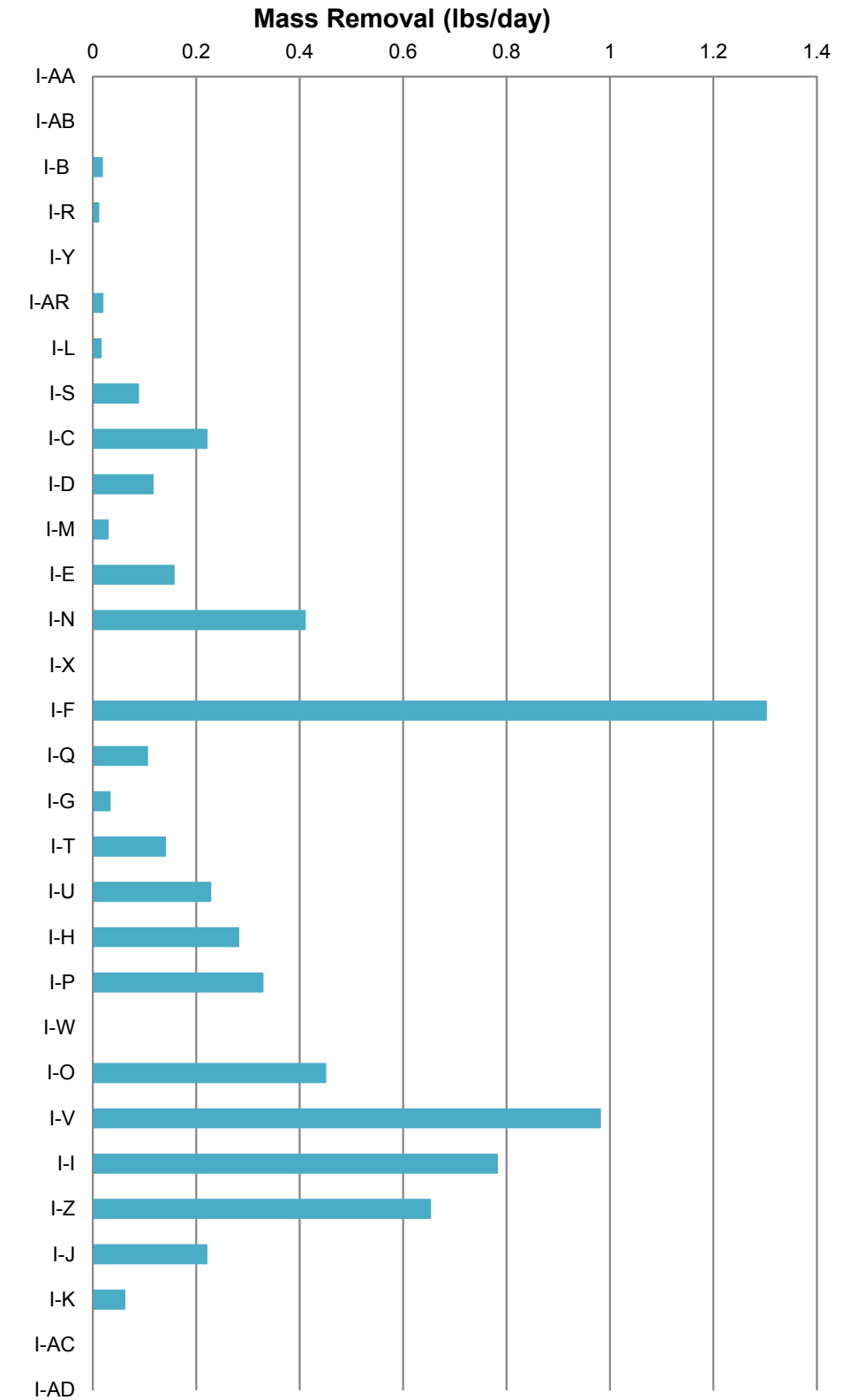
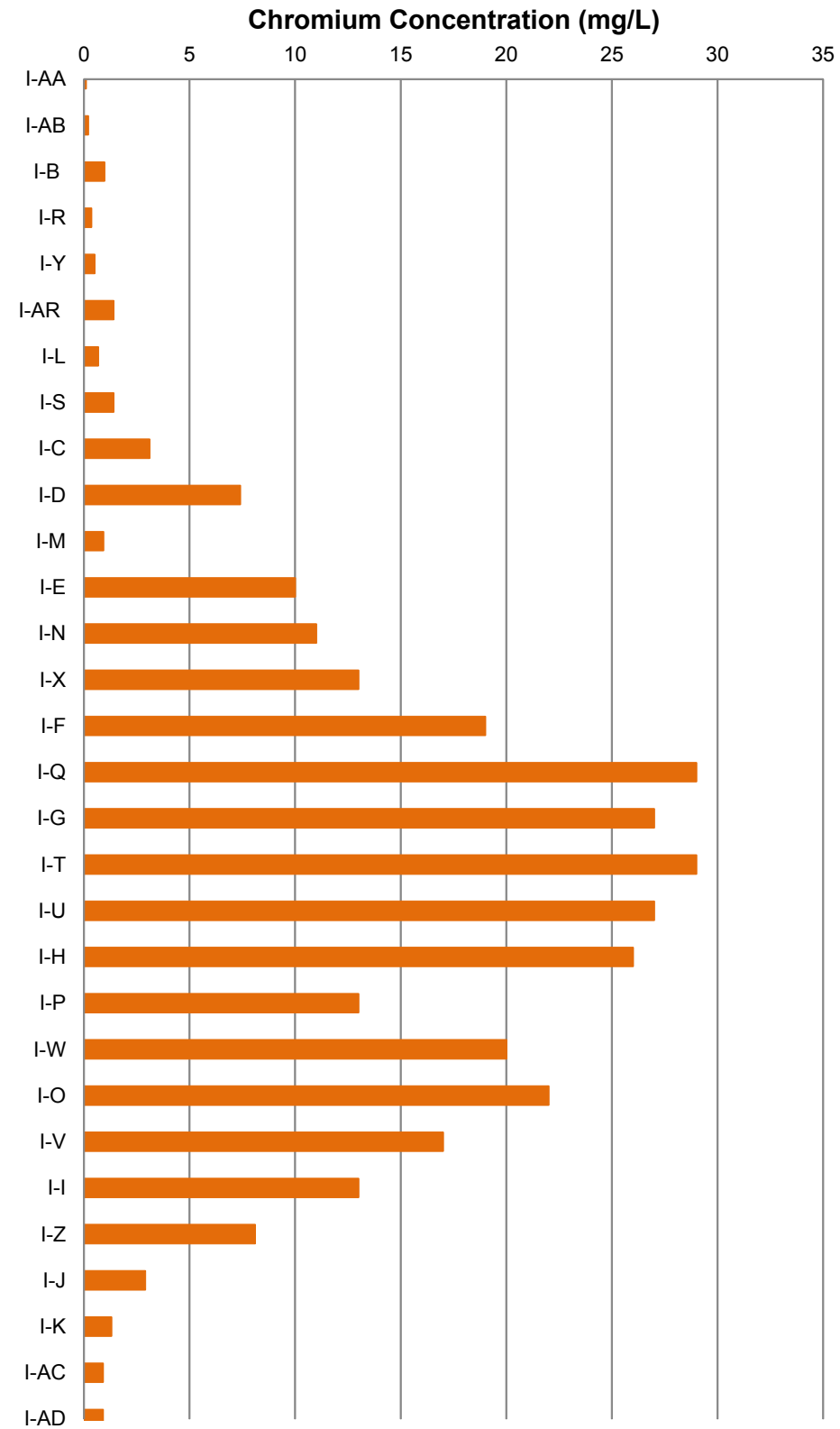
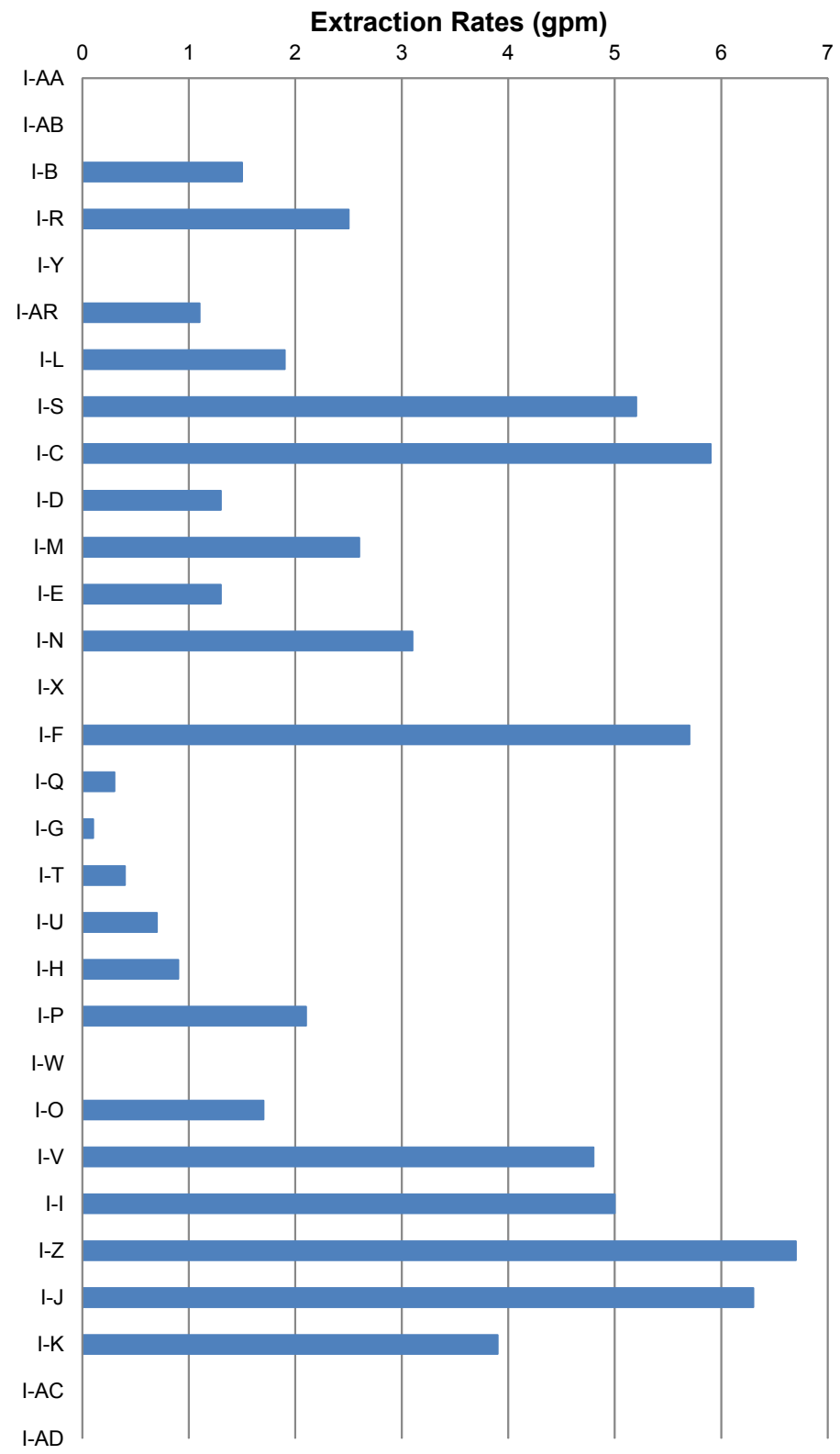

Current Chromium Removal at the Interceptor Well Field
Nevada Environmental Response Trust Site
Henderson, Nevada

Figure
E-6

Drafter: EA

Date: 8/31/2012

Contract Number: 21-29100G

Approved by: AS

Revised: EA

Extraction Rate (gpm)

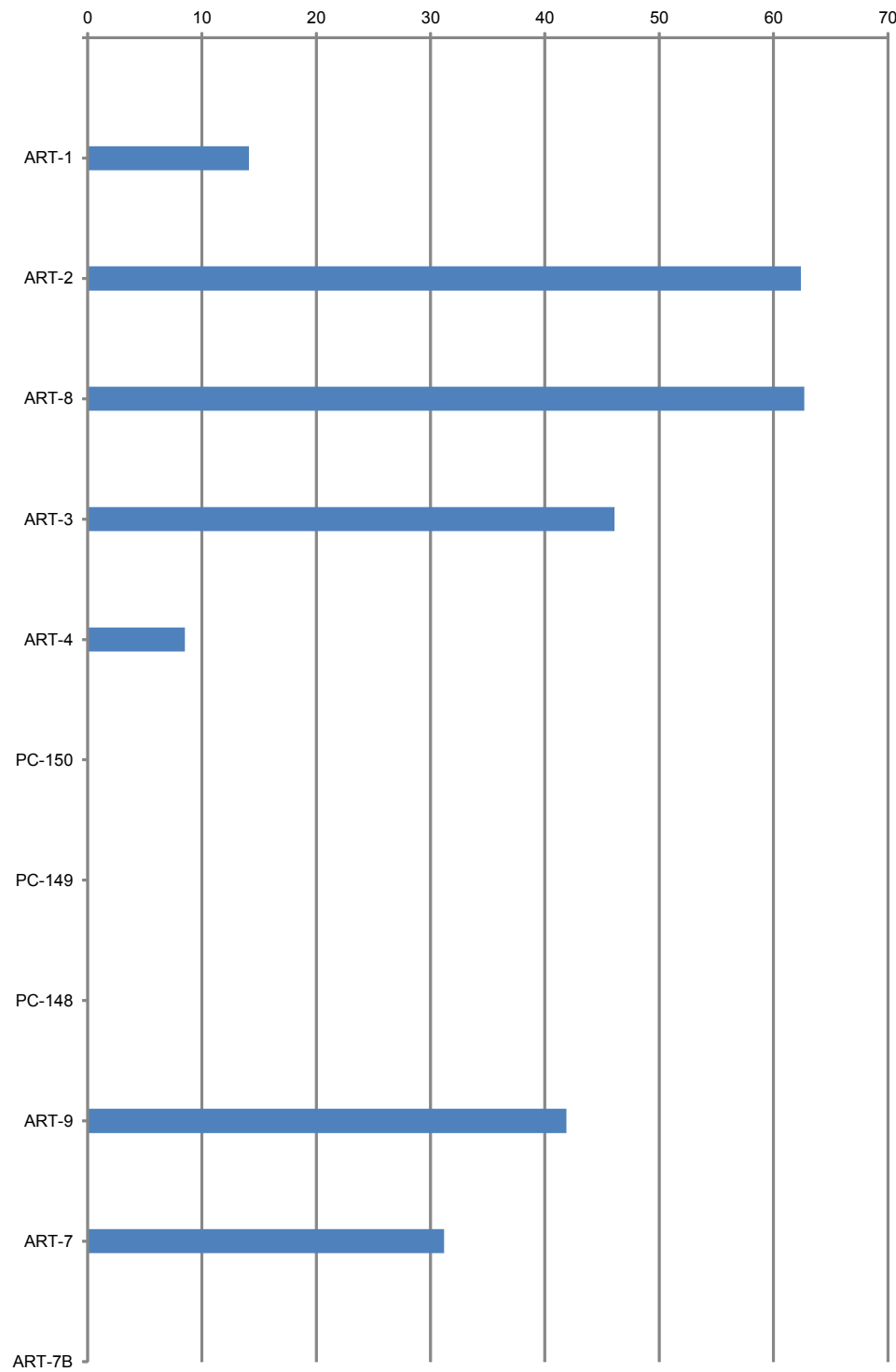

Perchlorate Concentration (mg/L)

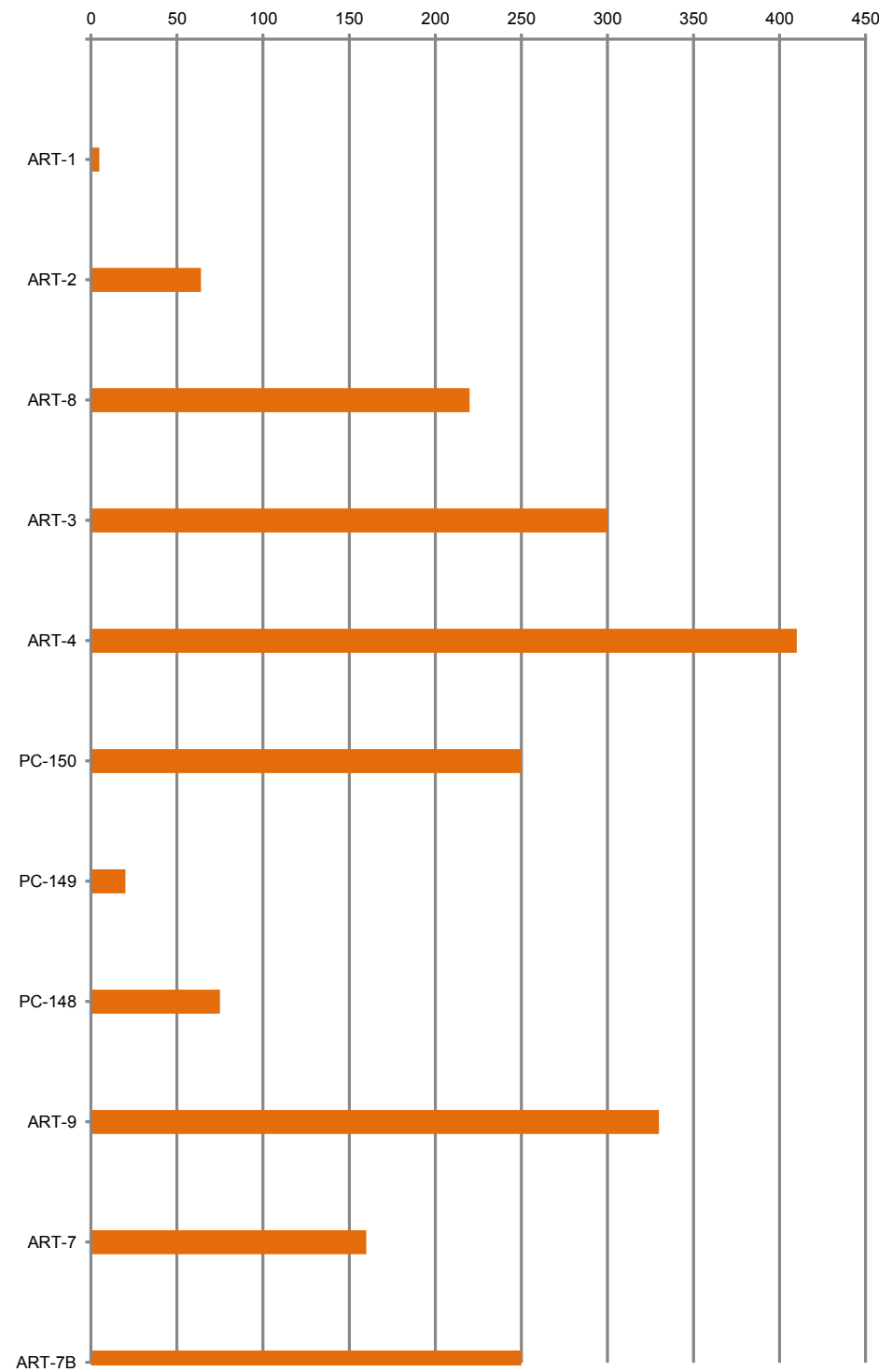

Mass Removal (lbs/day)

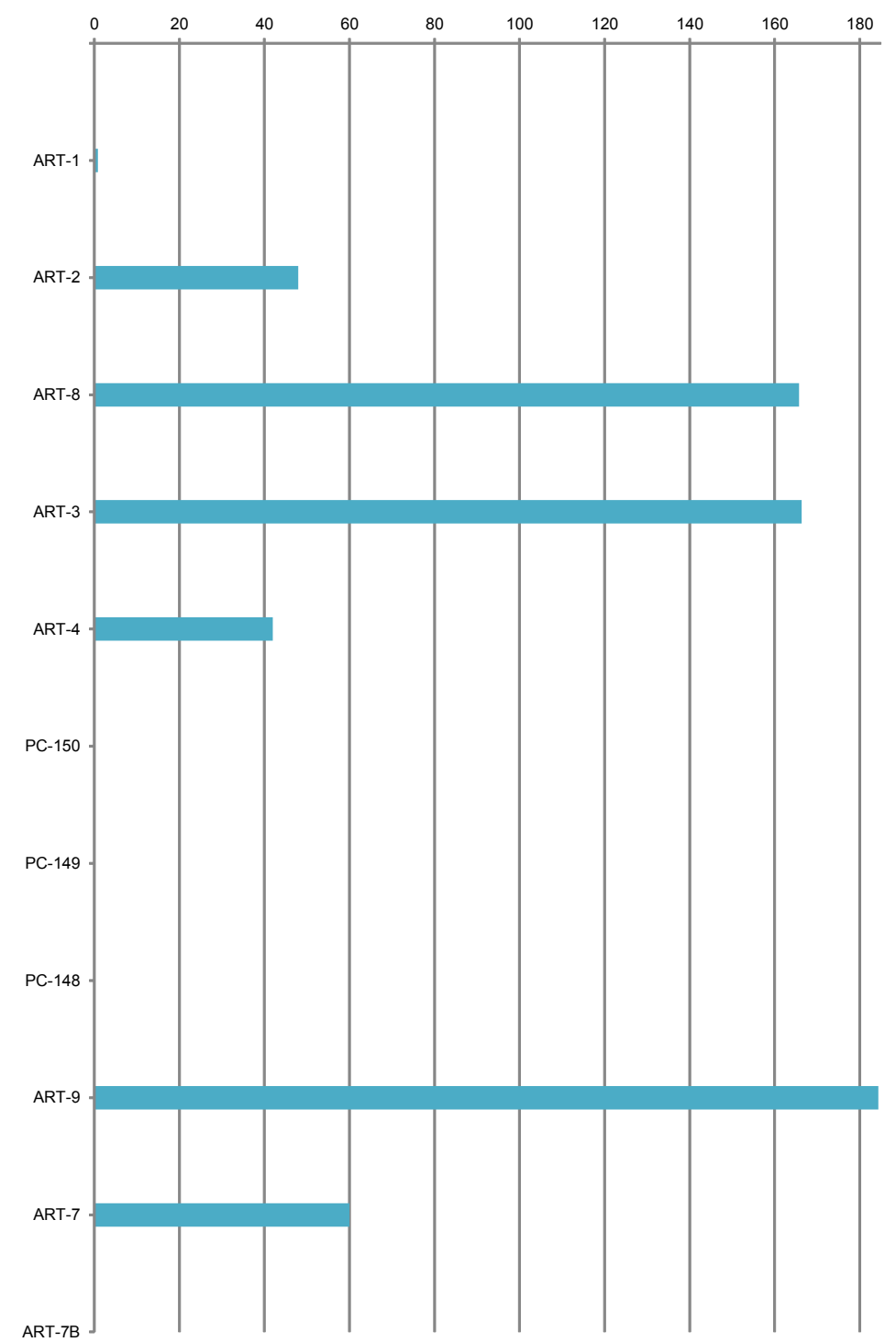

Path: H:\LePetomane\NERT\GWA\Annual Performance Reports\2012 Annual\Appendix E - Mass Removal Plots\Figures\Figure E7 - Perchlorate removal-AWF.mxd



Current Perchlorate Removal at the Athens Road Well Field
 Nevada Environmental Response Trust Site
 Henderson, Nevada

Figure
E-7

Drafter: EA

Date: 8/31/2012

Contract Number: 21-29100G

Approved by: AS

Revised: EA

Extraction Rate (gpm)

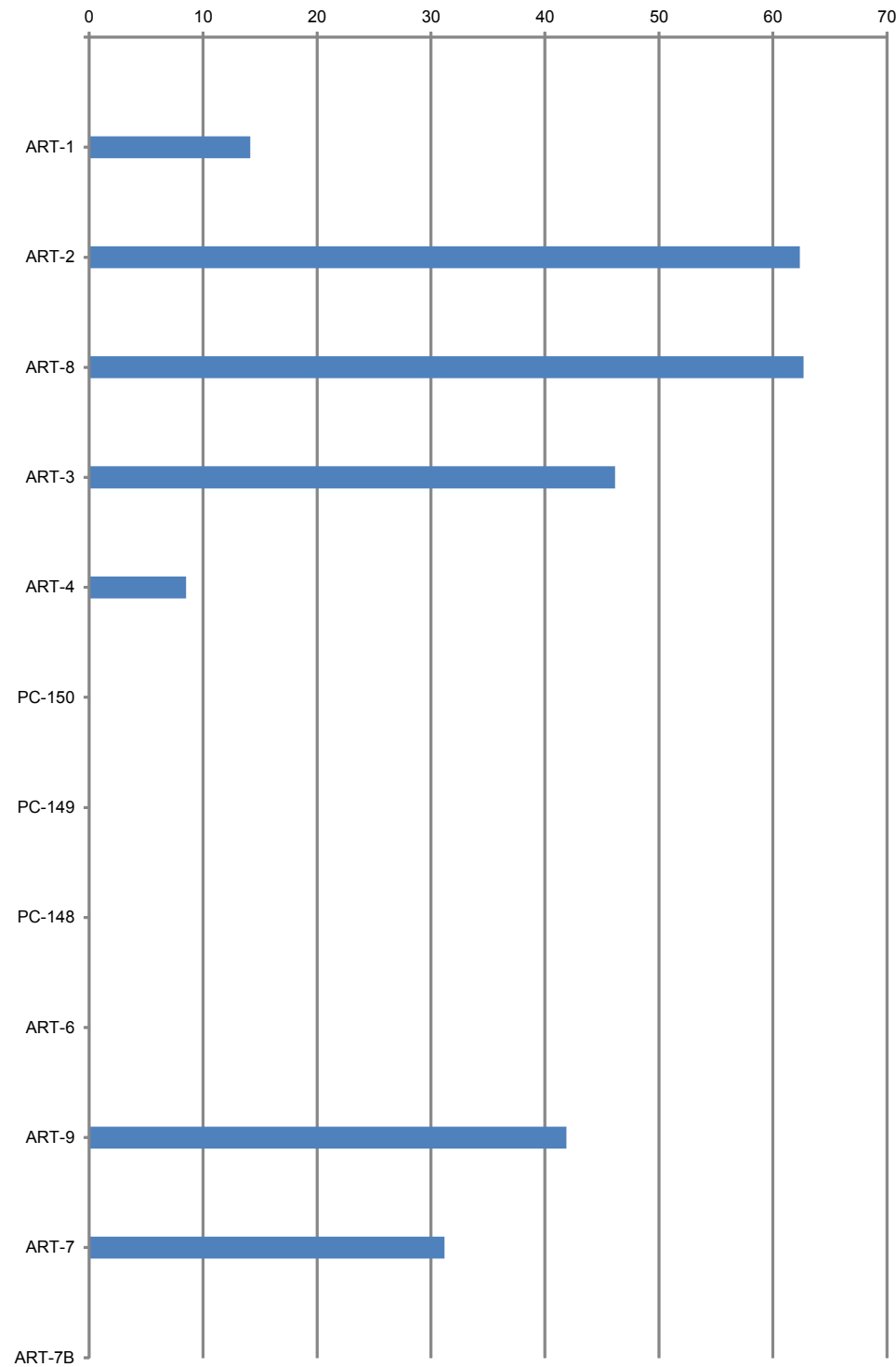

Chromium Concentration (mg/L)

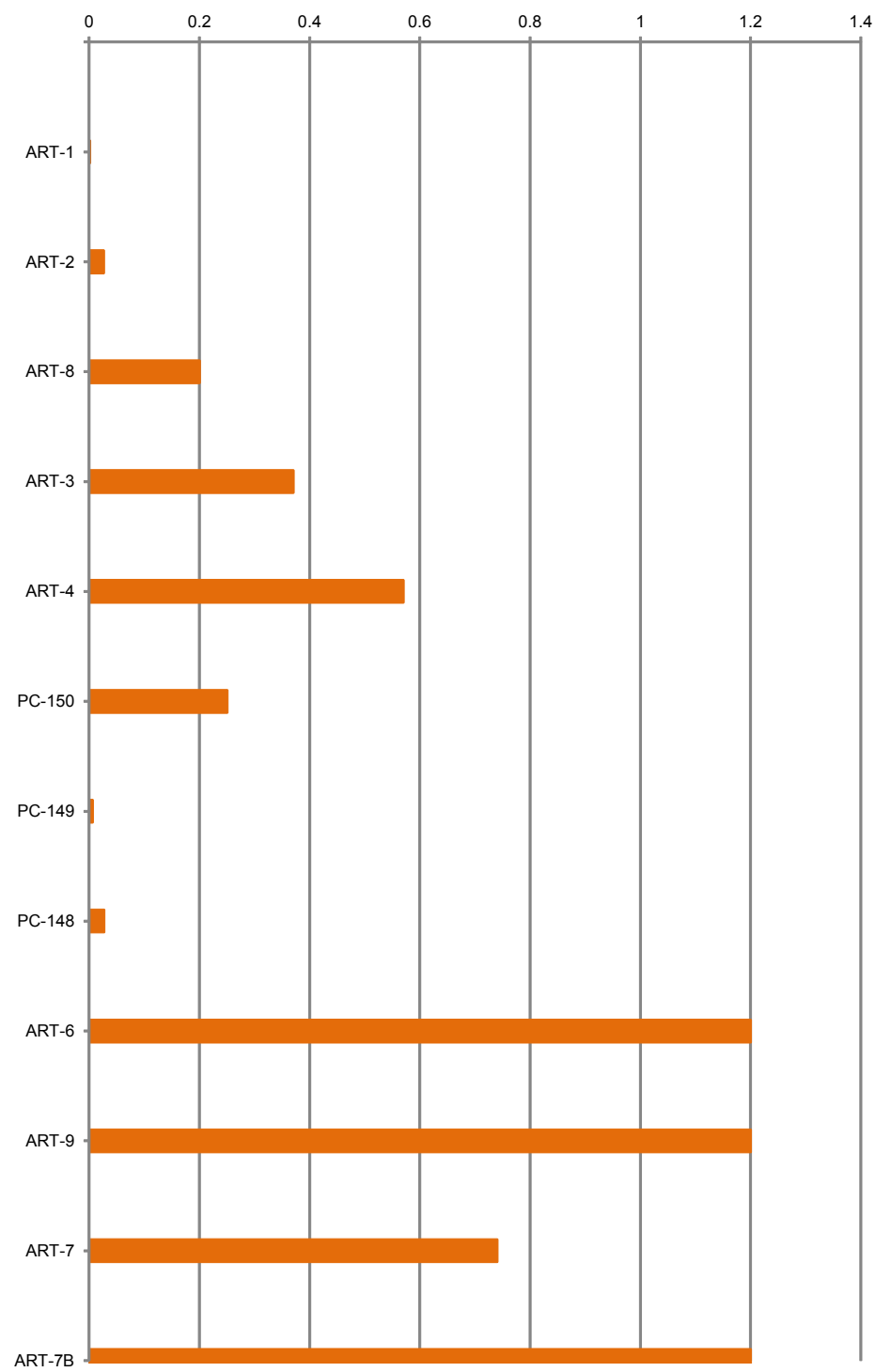

Mass Removal (lbs/day)

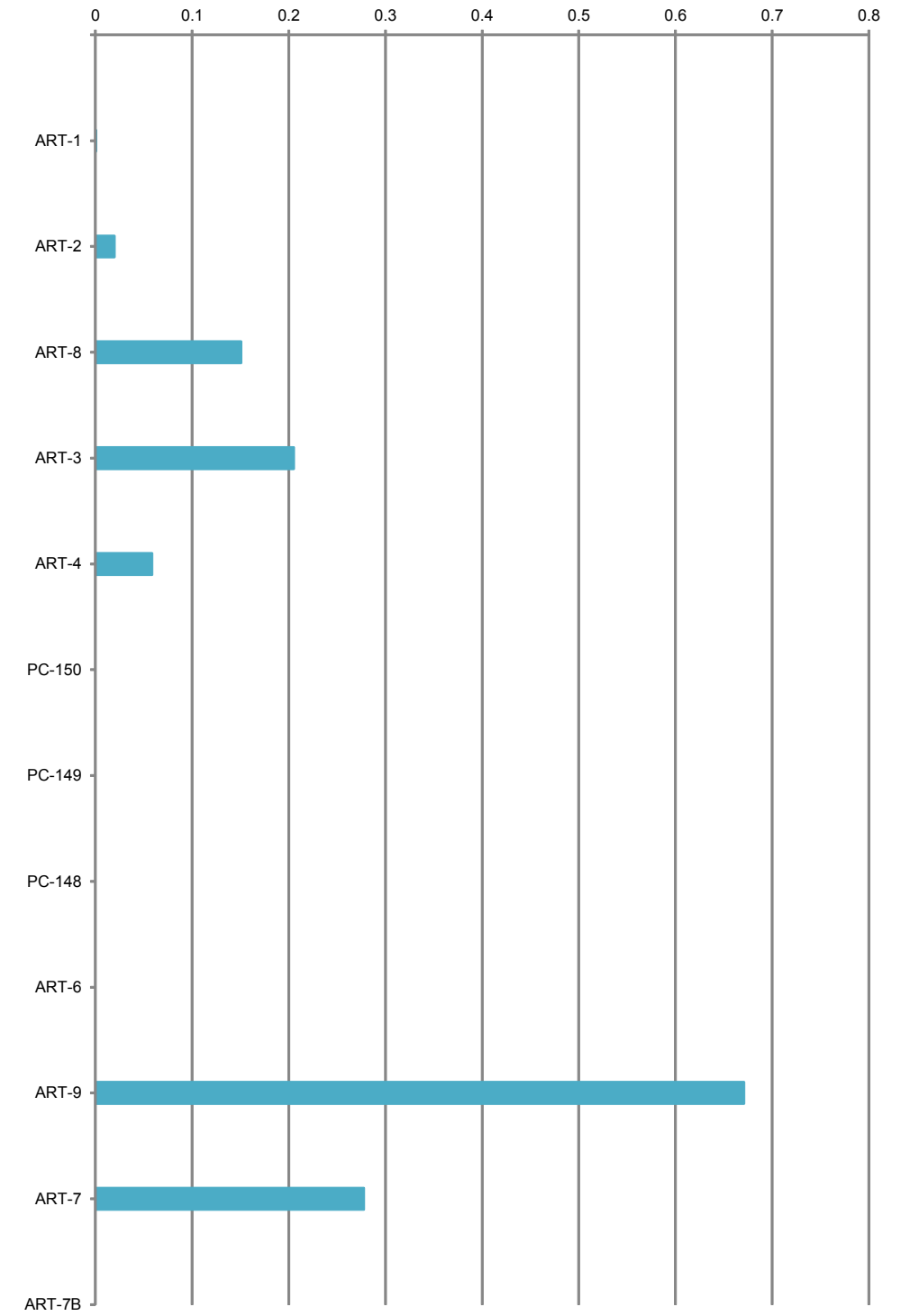

Path: H:\LePetomane\NERT\GWA\Annual Performance Reports\2012 Annual\Appendix E - Mass Removal Plots\Figures\Figure E8 - Chromium removal-AWF.mxd



Current Chromium Removal at the Athens Road Well Field
 Nevada Environmental Response Trust Site
 Henderson, Nevada

Figure
E-8

Drafter: EA

Date: 8/31/2012

Contract Number: 21-29100G

Approved by: AS

Revised: EA

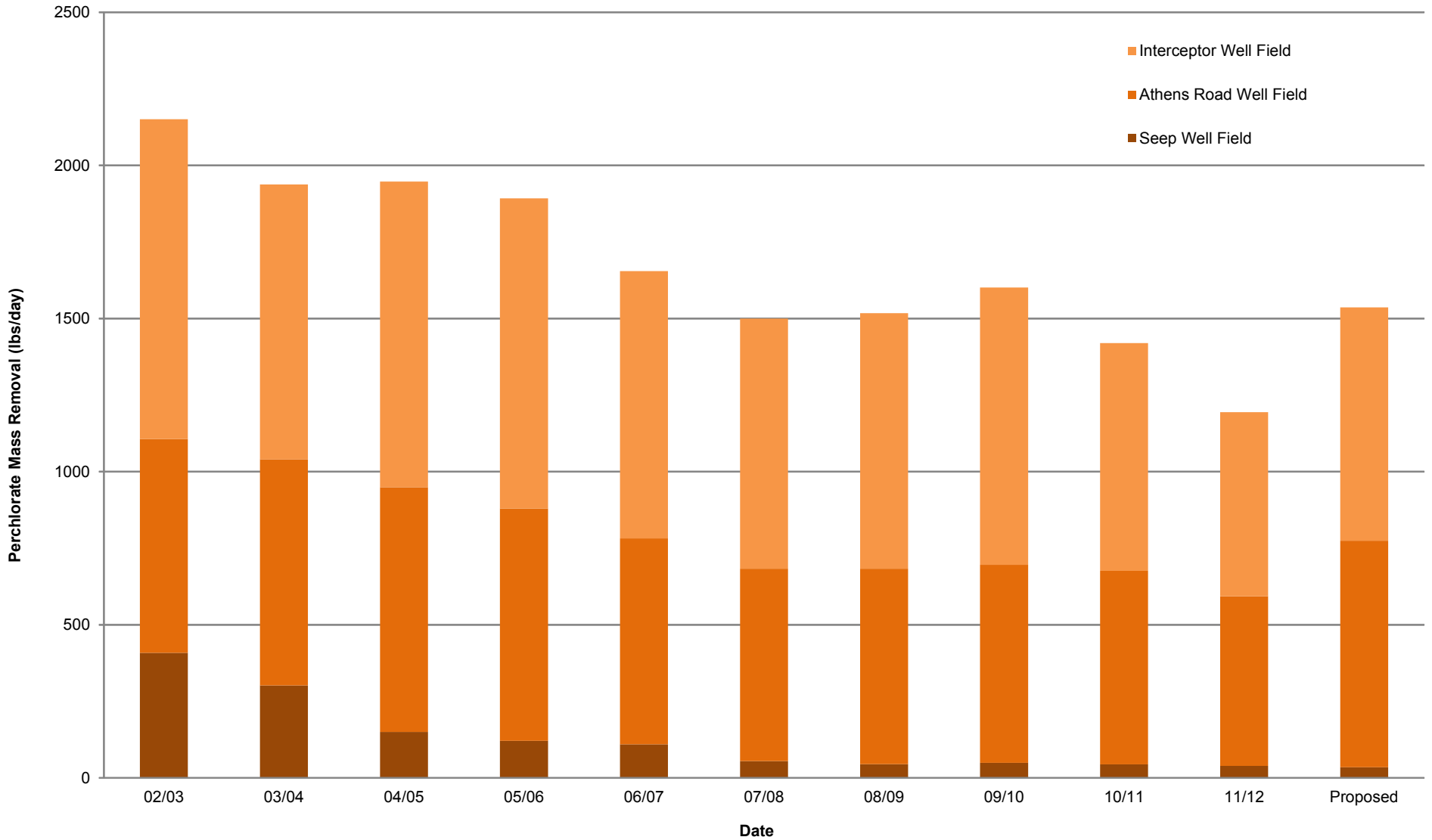

Historic and Proposed Perchlorate Mass Removal
 Nevada Environmental Response Trust Site
 Henderson, Nevada

Figure

E-9

Drafter: RS

Date: 8/28/12

Contract Number: 21-29100G

Approved:

Revised:

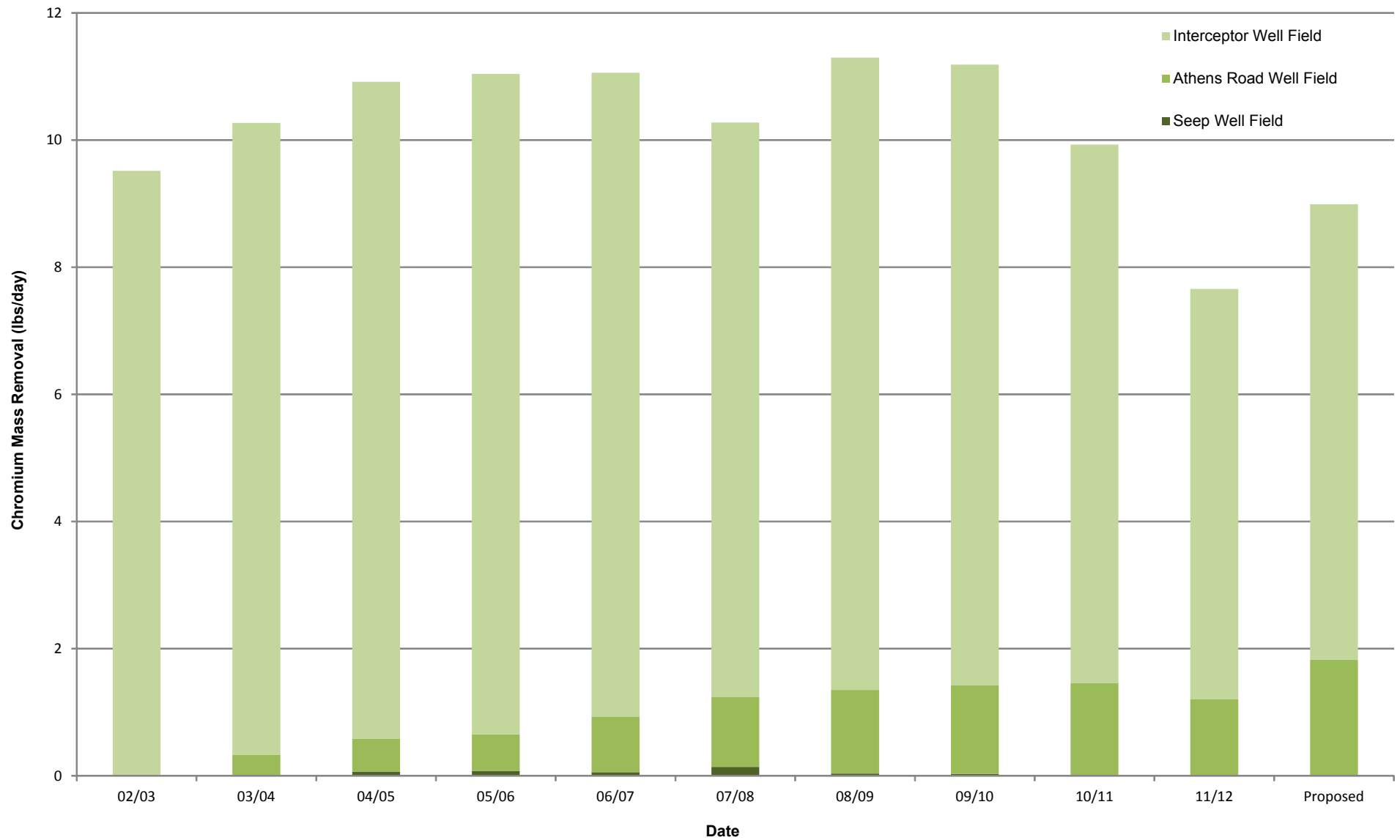

Historic and Proposed Chromium Mass Removal
 Nevada Environmental Response Trust Site
 Henderson, Nevada

Figure

E-10

Drafter: RS

Date: 8/28/12

Contract Number: 21-29100G

Approved:

Revised:

Attachment F-1
Historical Extraction Rates and Mass Removal
Plots for all Wells in the Interceptor Well Field

Interceptor Well Field (IWF) Summary

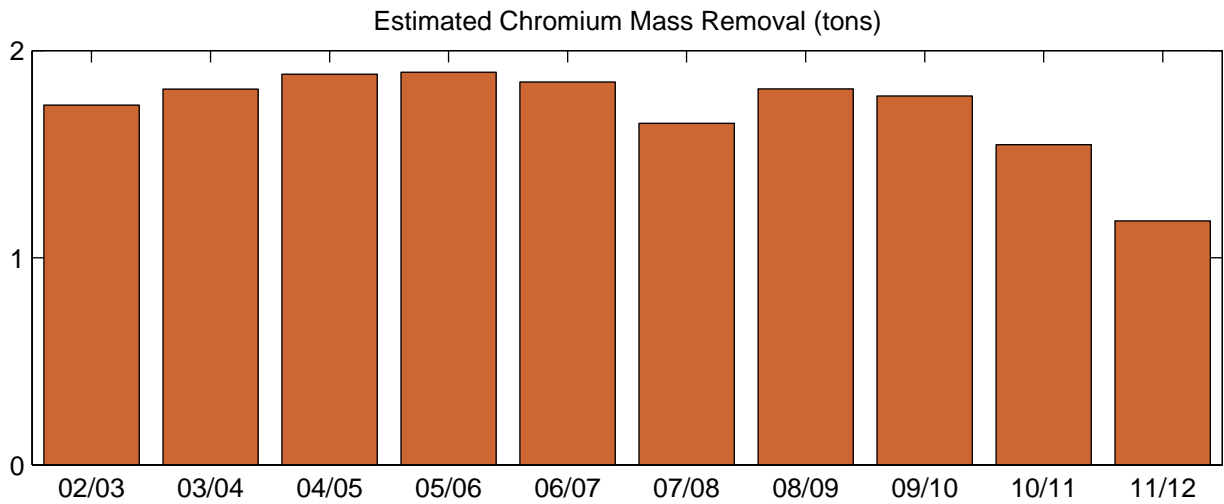
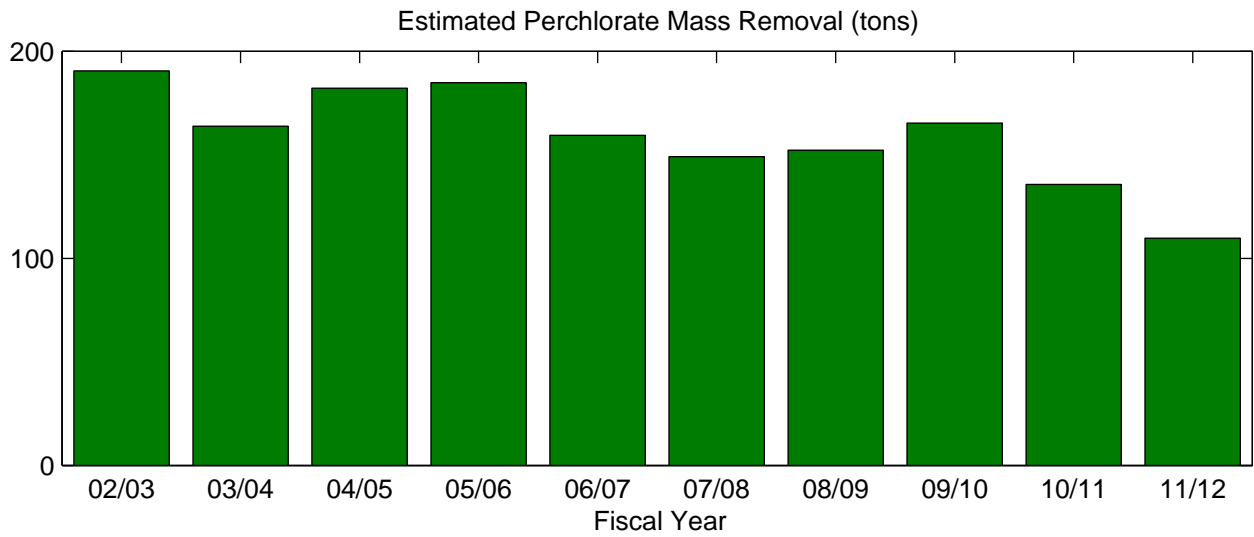
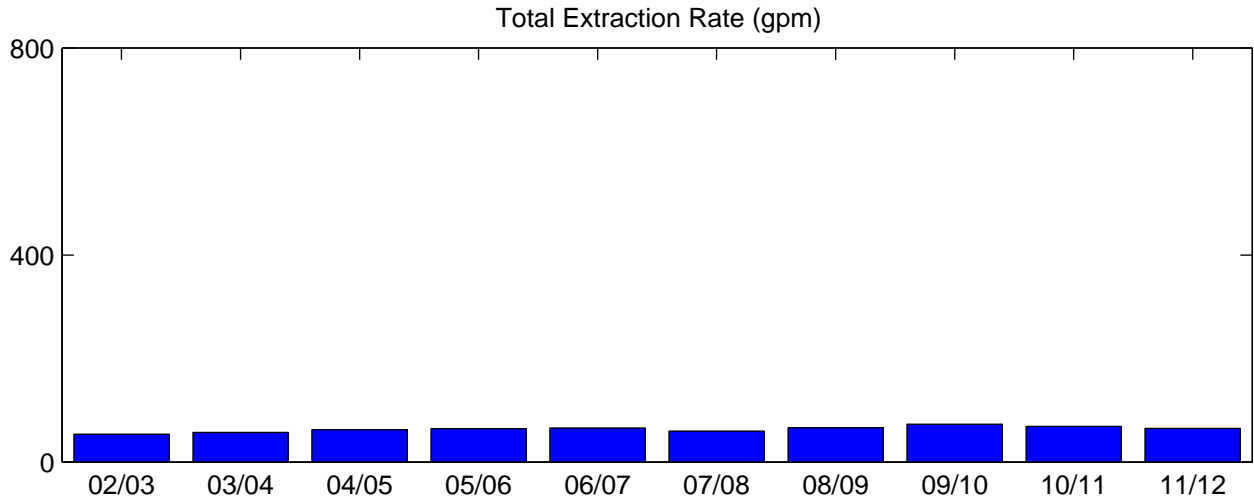

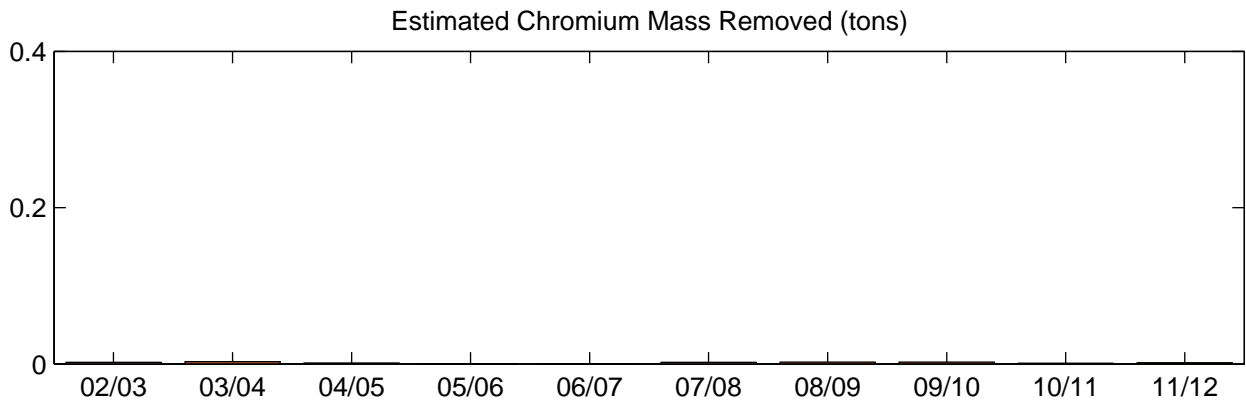
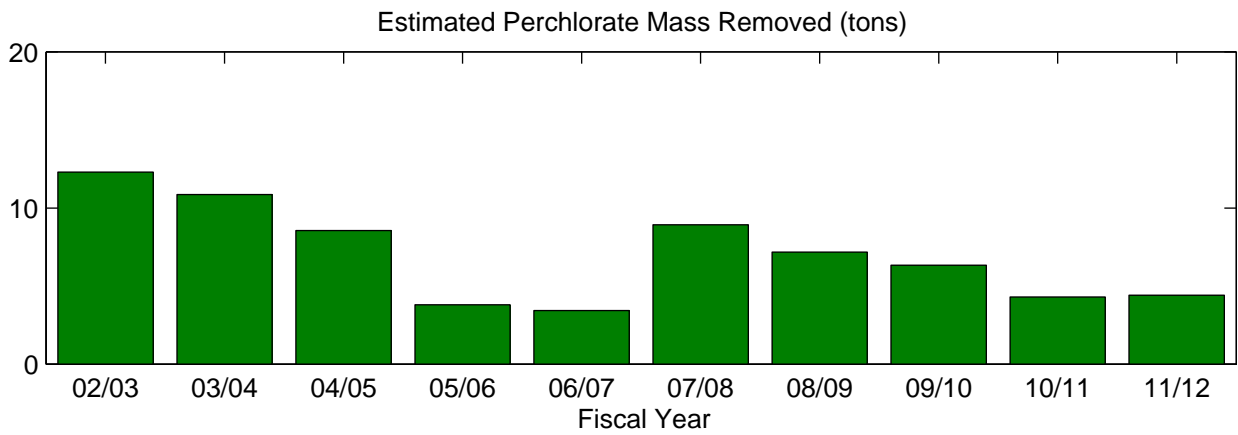
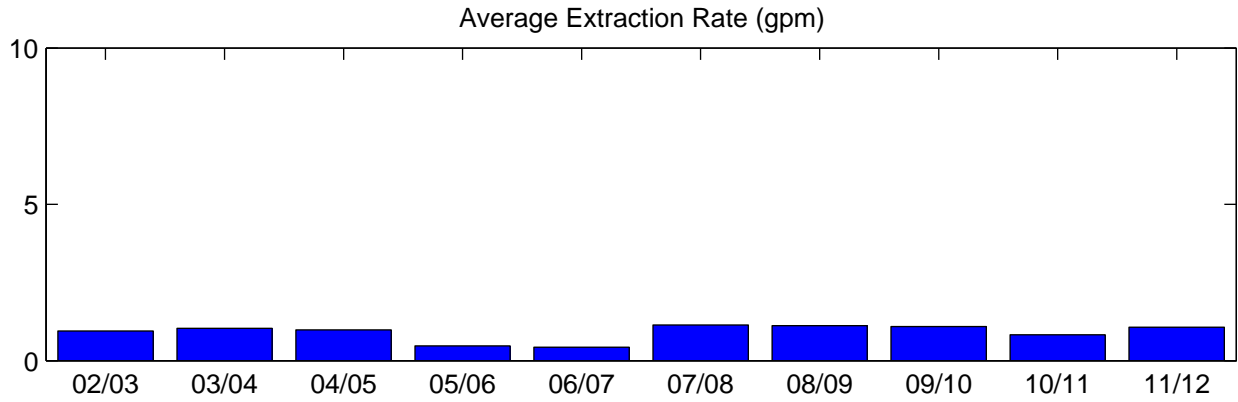
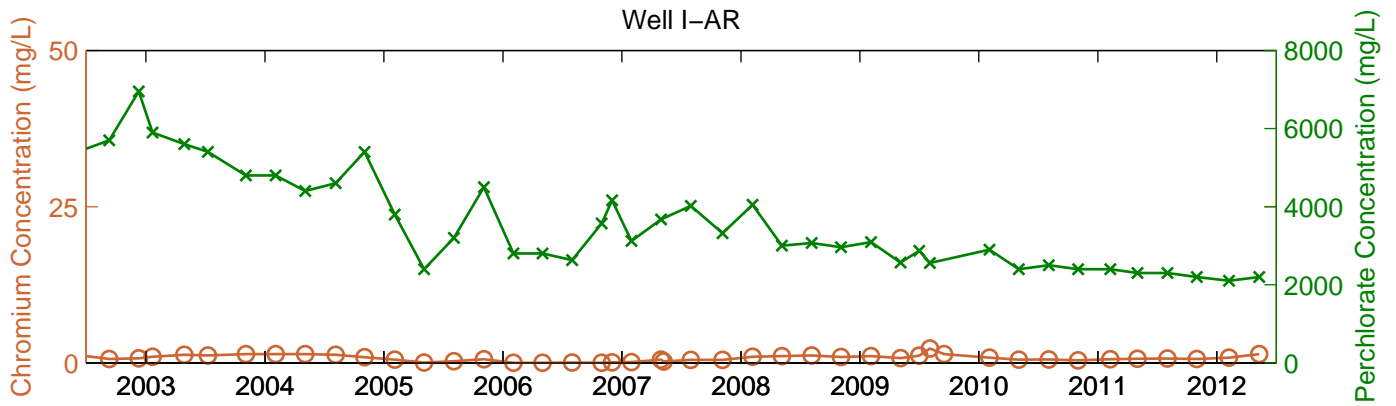

* Extraction rates for FY02/03 are the average of discharge rates reported for December 2002 and June 2003.

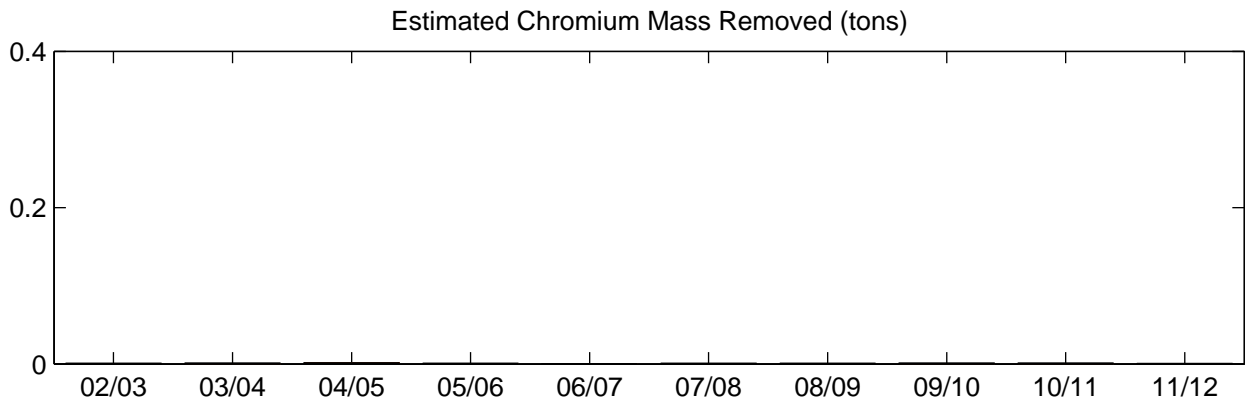
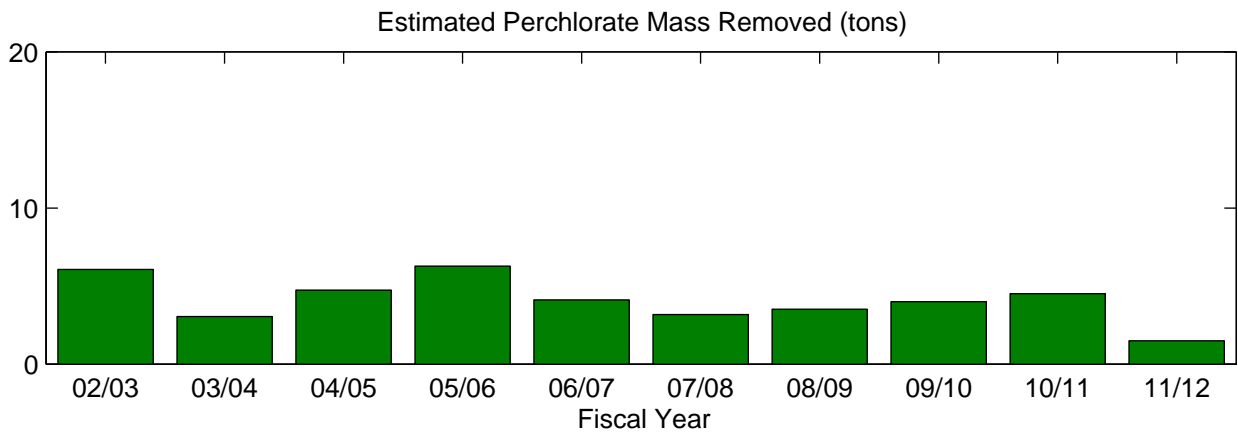
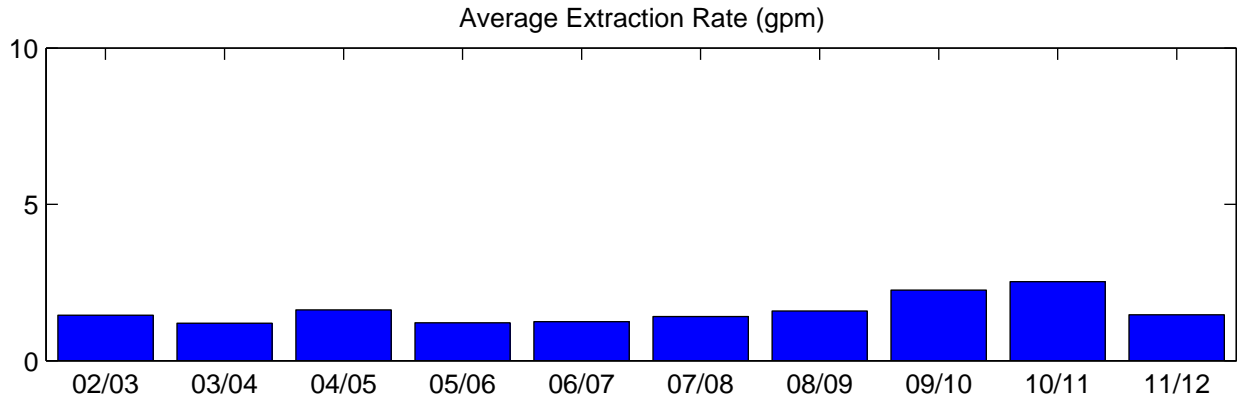
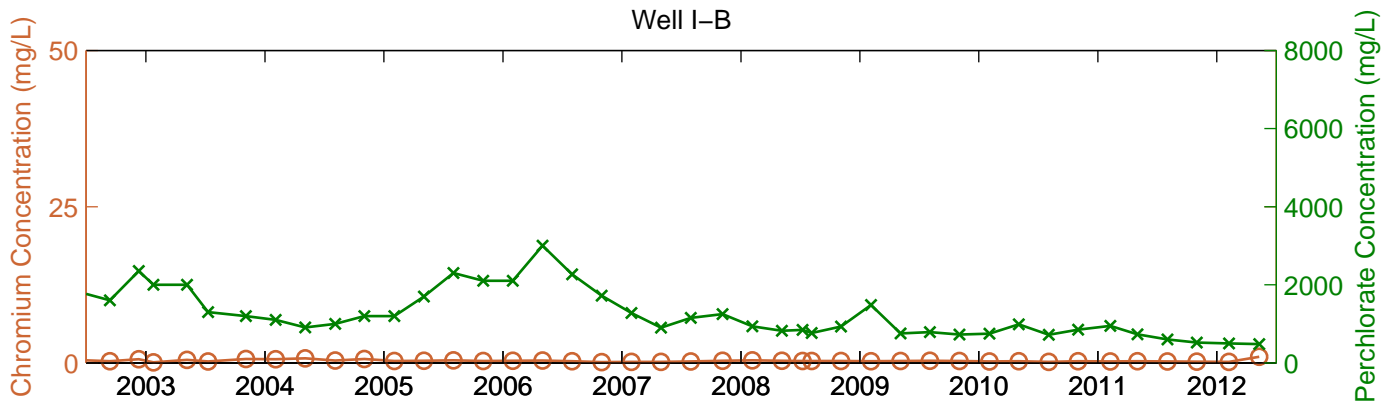

* Extraction rates for FY02/03 are the average of discharge rates reported for December 2002 and June 2003.

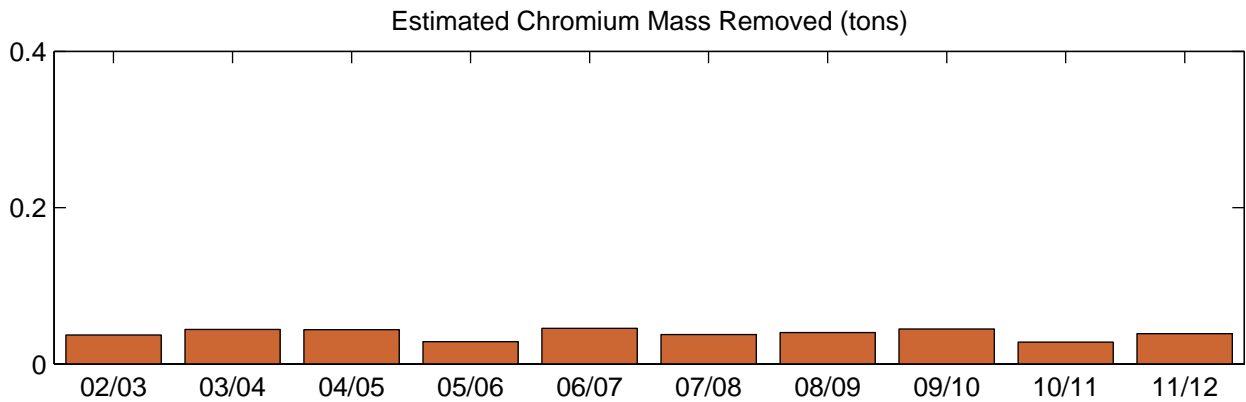
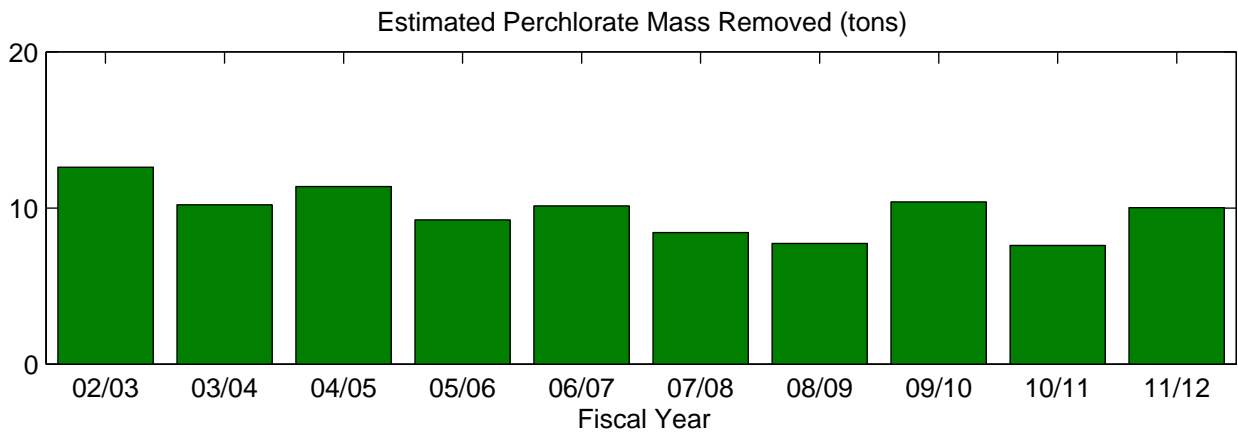
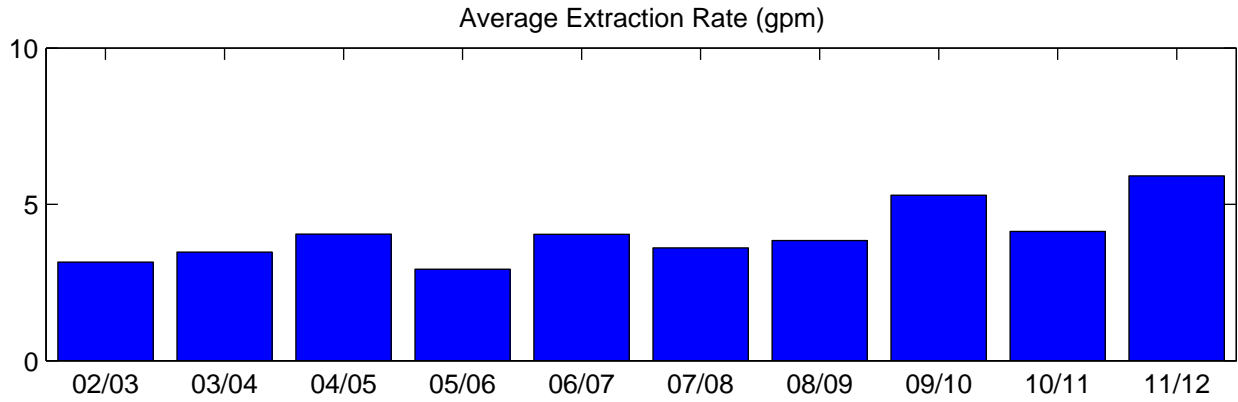
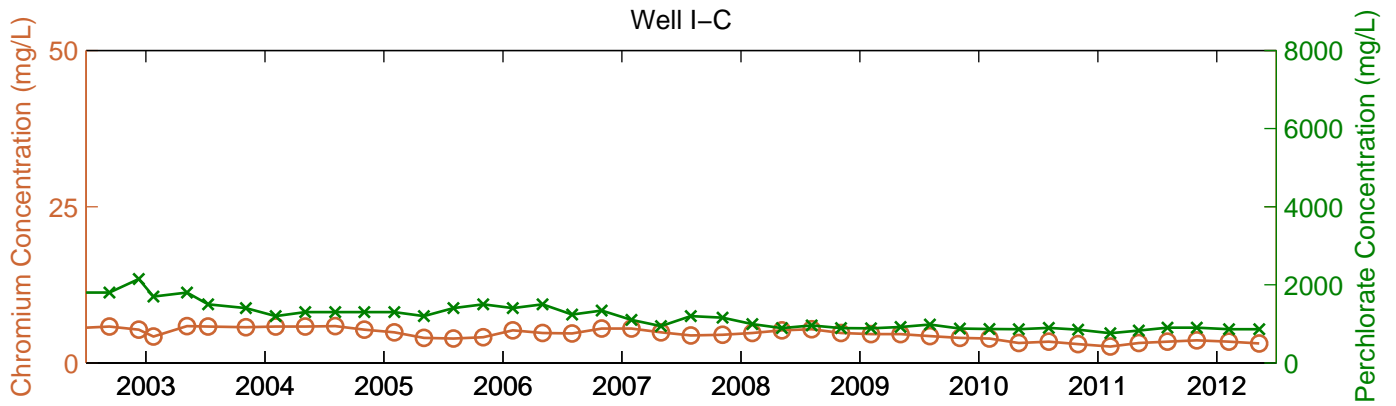

* Extraction rates for FY02/03 are the average of discharge rates reported for December 2002 and June 2003.

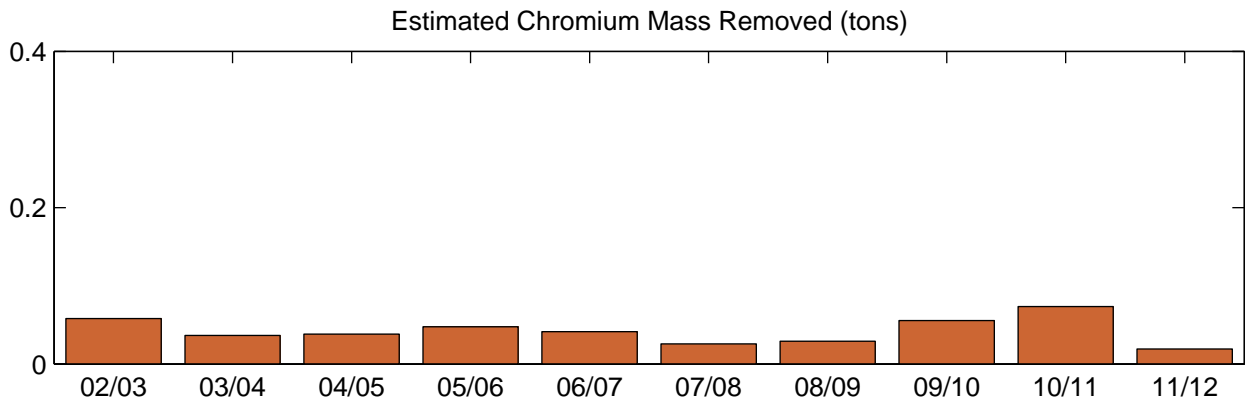
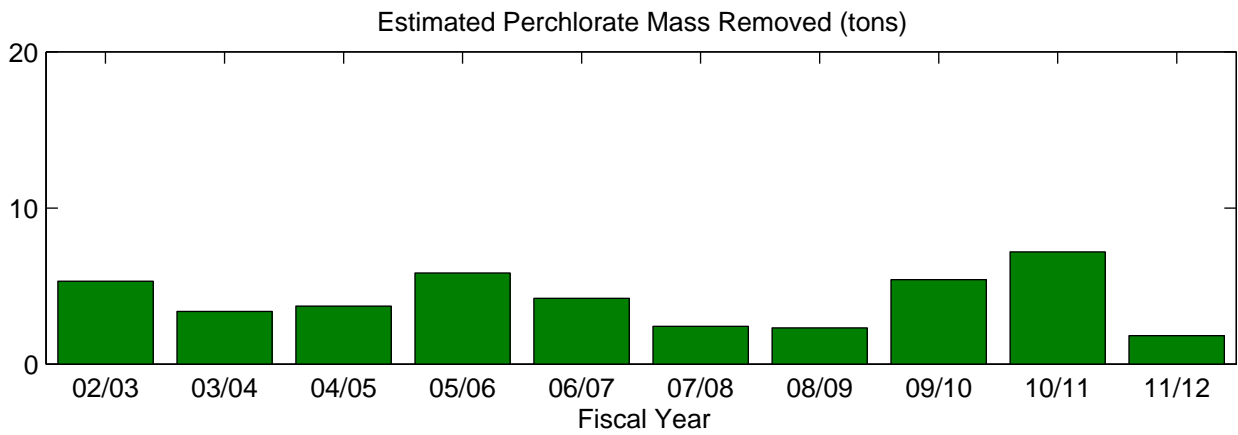
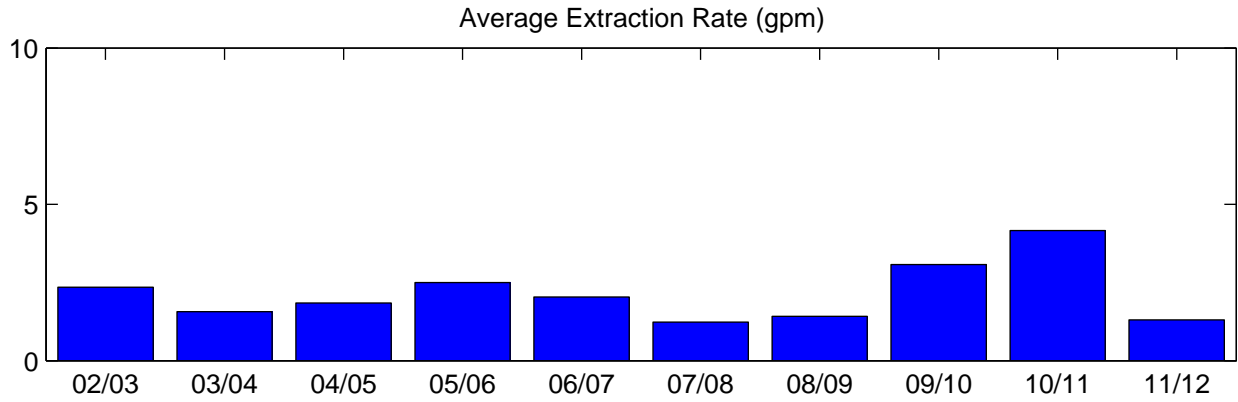
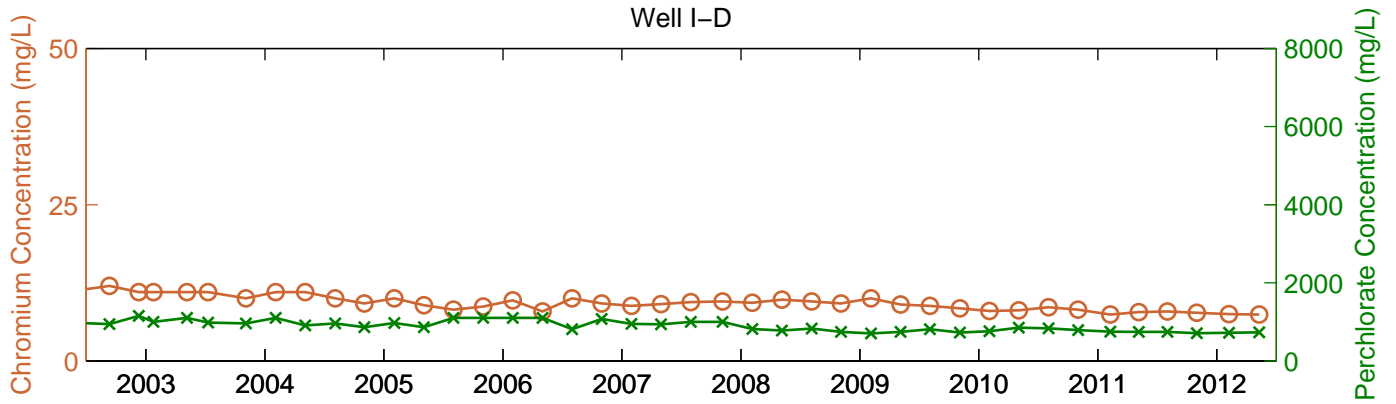

* Extraction rates for FY02/03 are the average of discharge rates reported for December 2002 and June 2003.

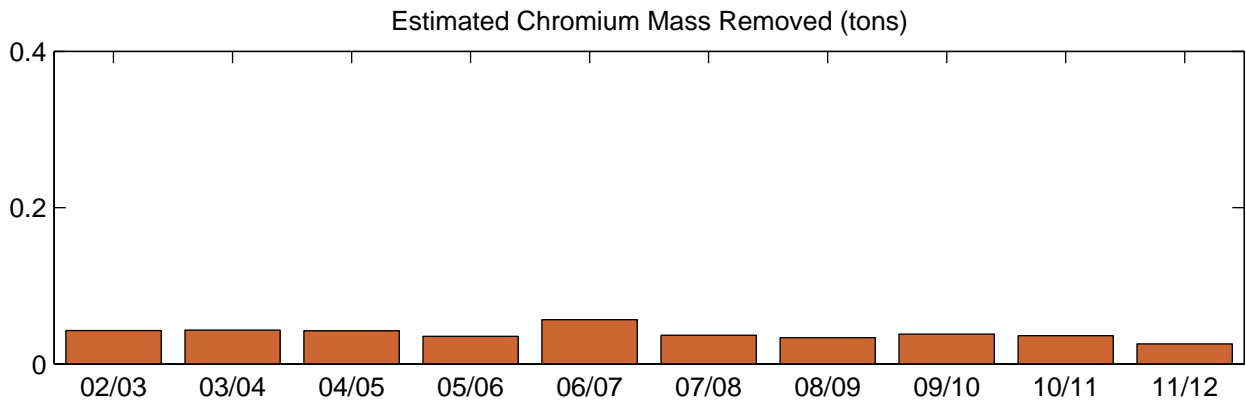
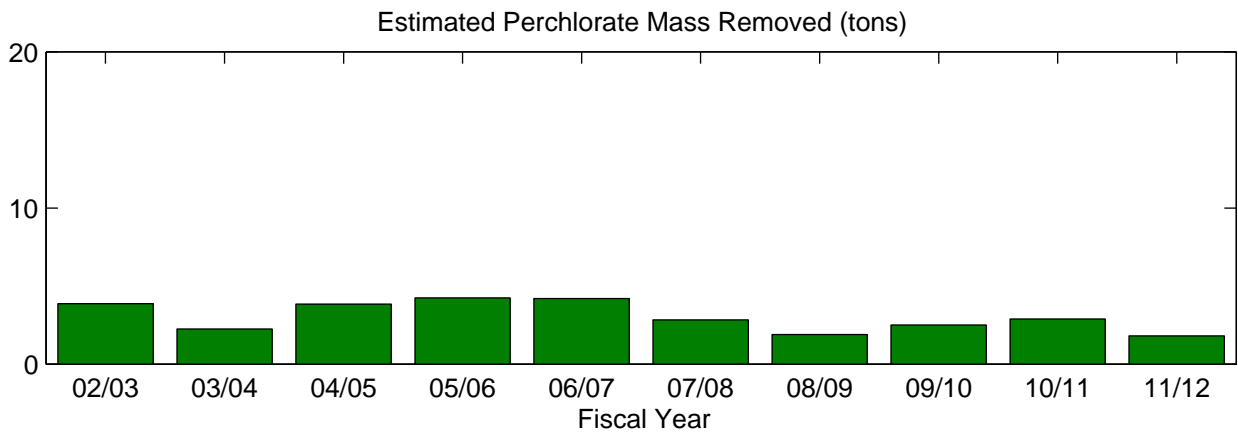
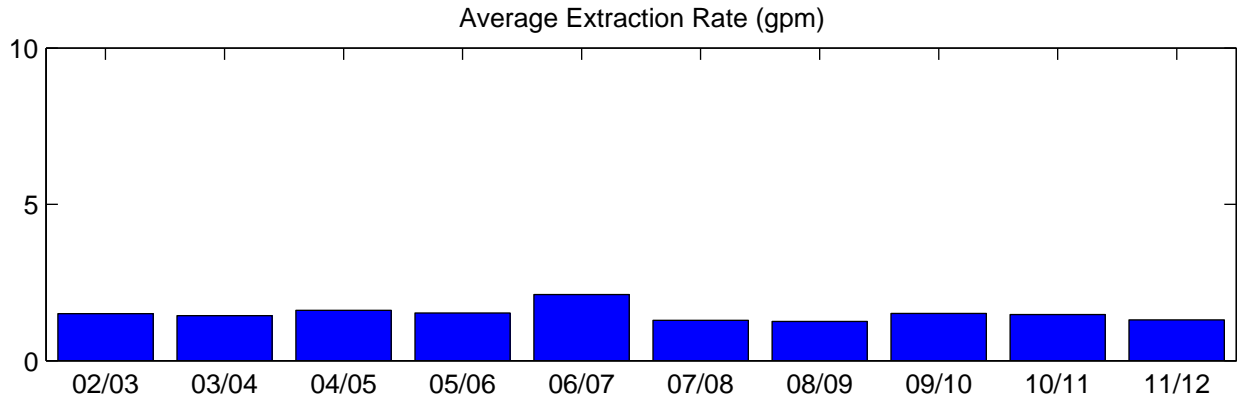
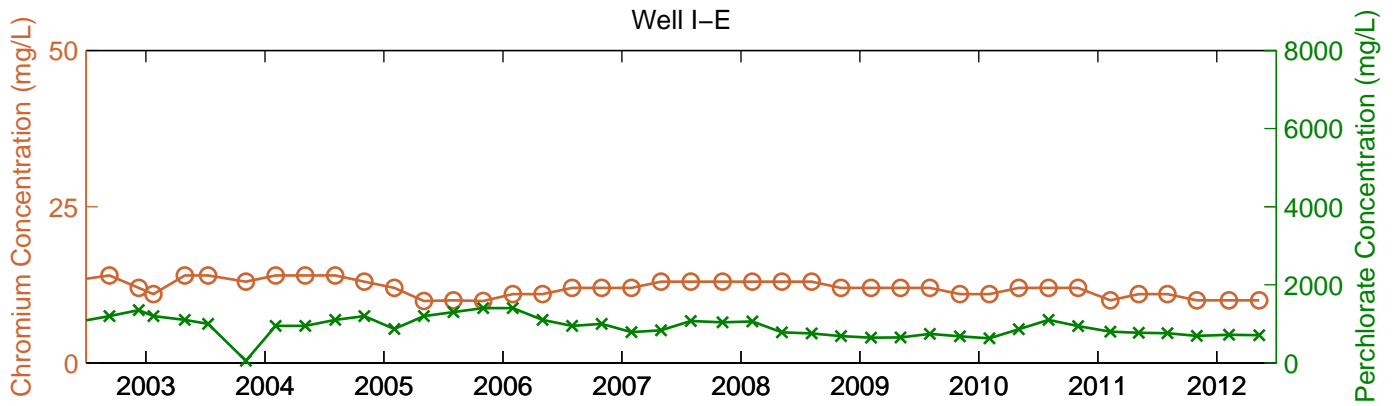

* Extraction rates for FY02/03 are the average of discharge rates reported for December 2002 and June 2003.

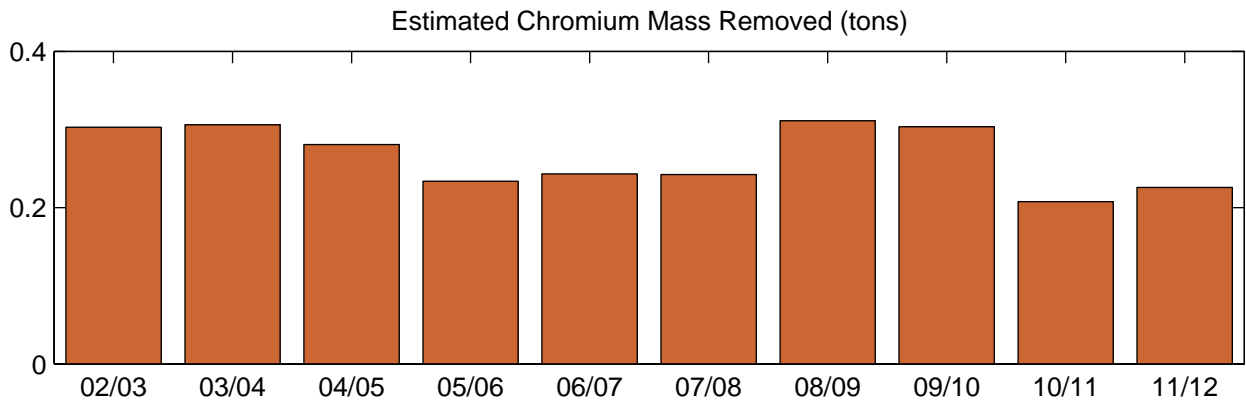
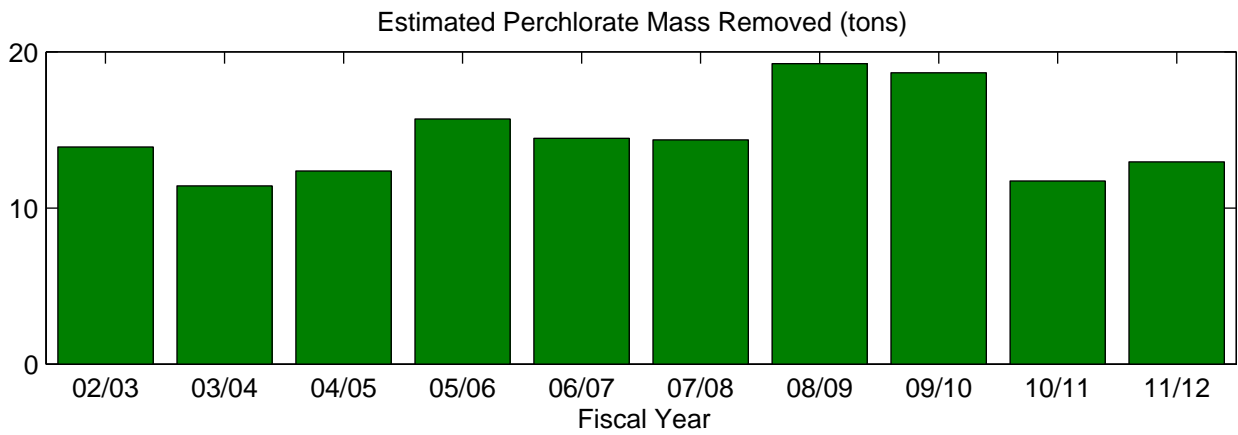
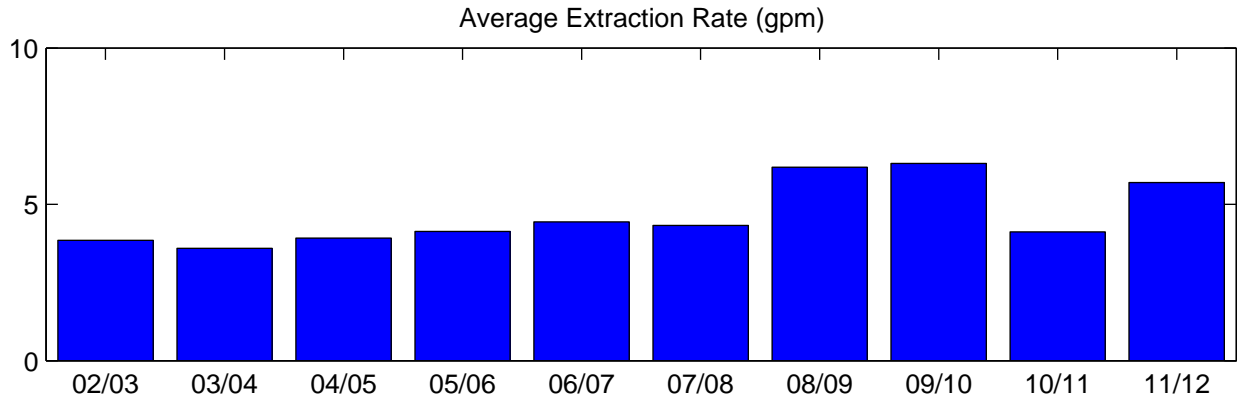
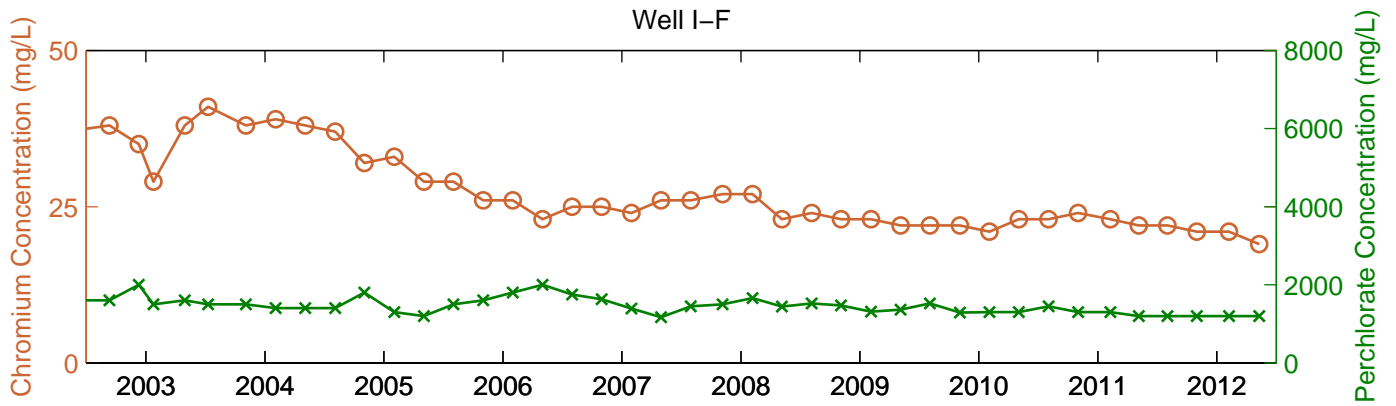

* Extraction rates for FY02/03 are the average of discharge rates reported for December 2002 and June 2003.

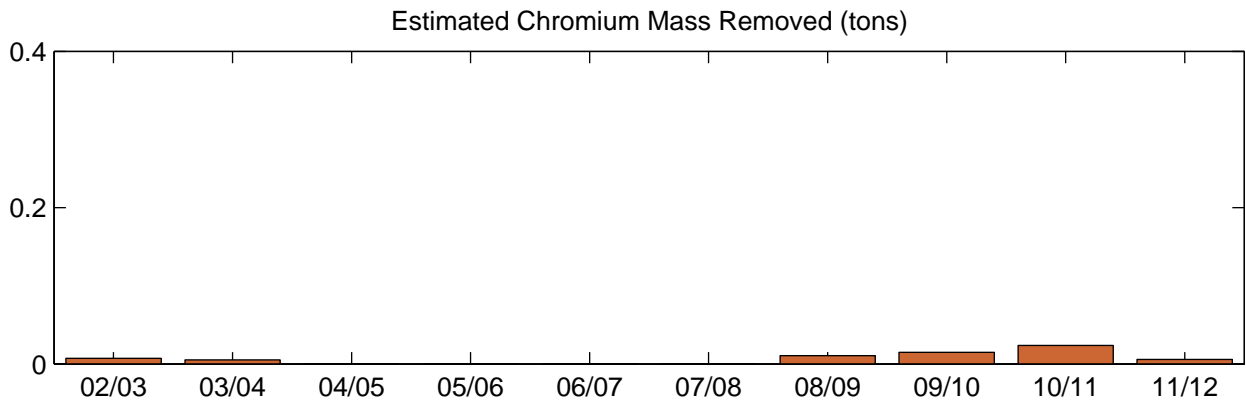
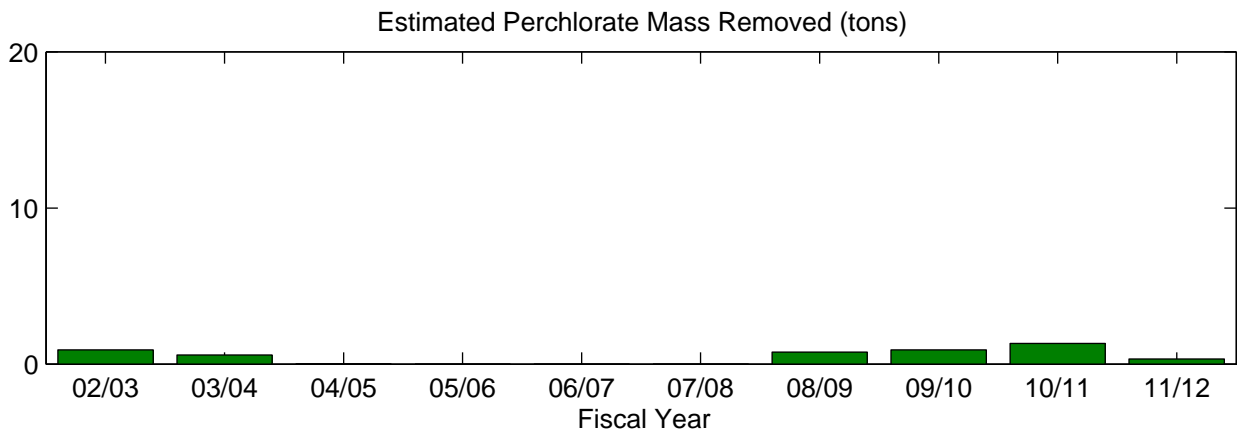
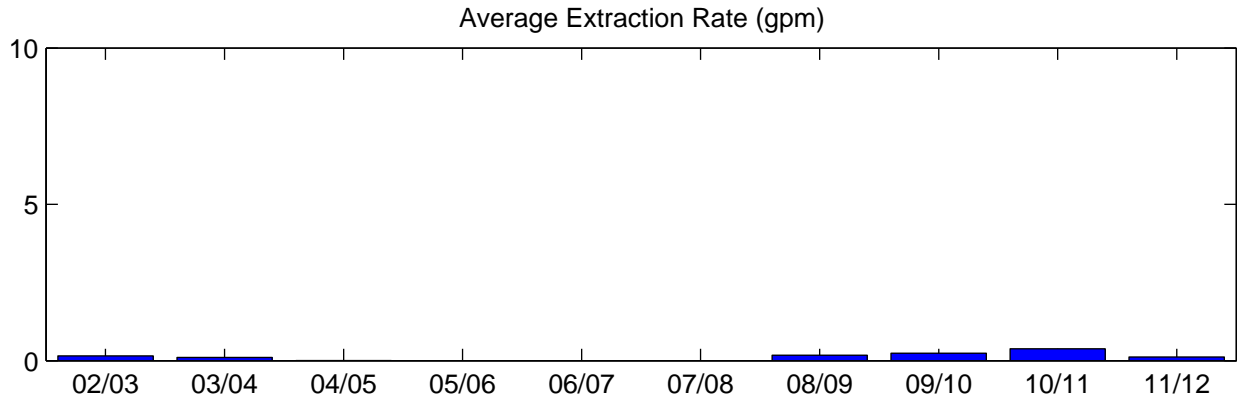
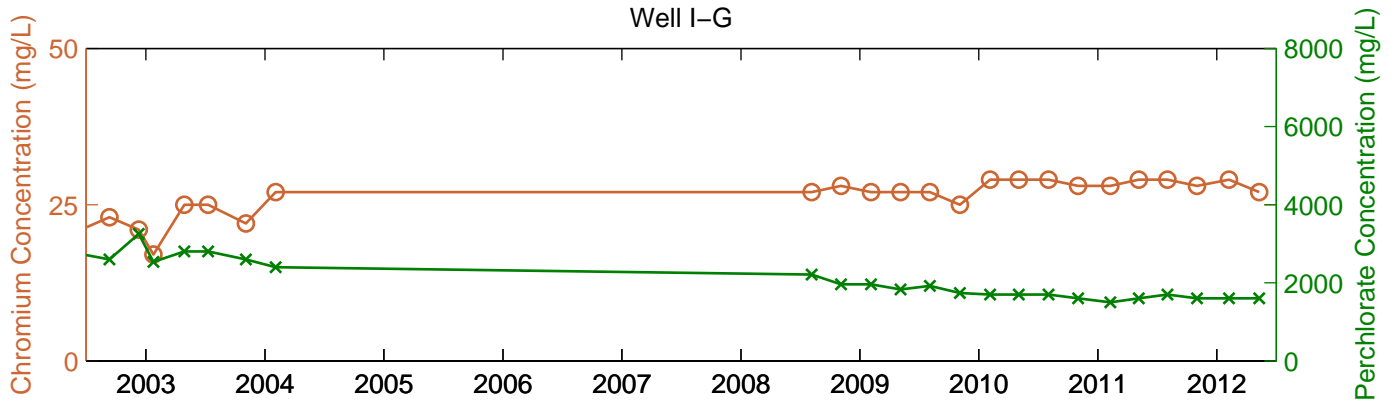

* Extraction rates for FY02/03 are the average of discharge rates reported for December 2002 and June 2003.

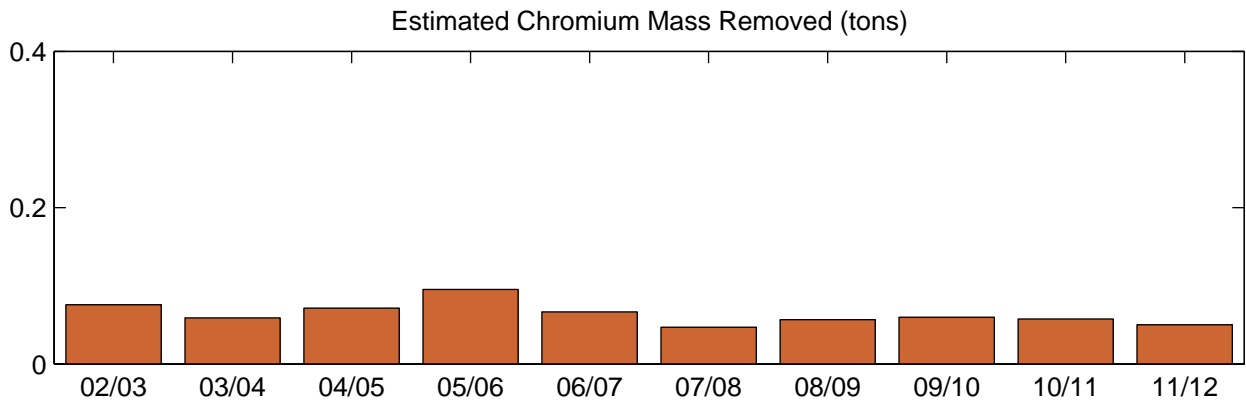
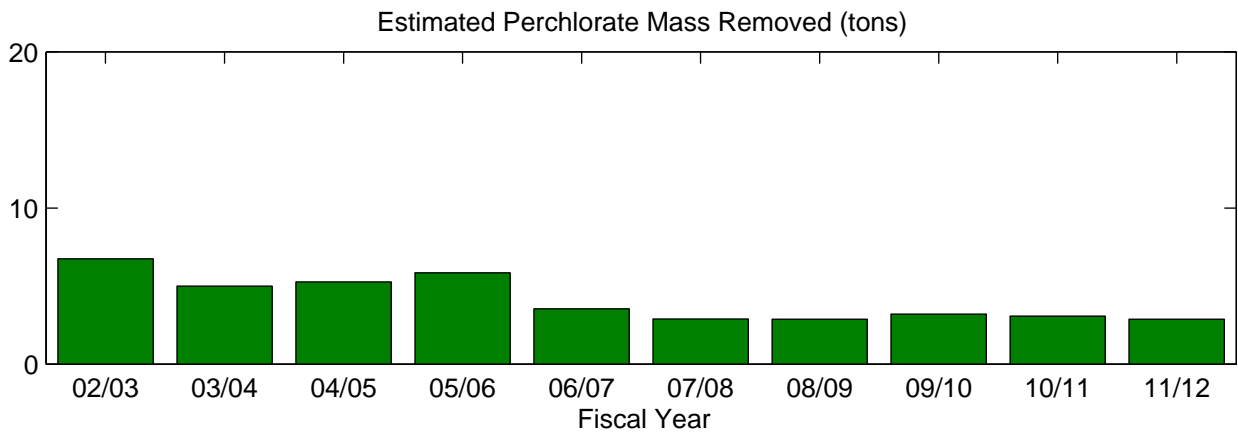
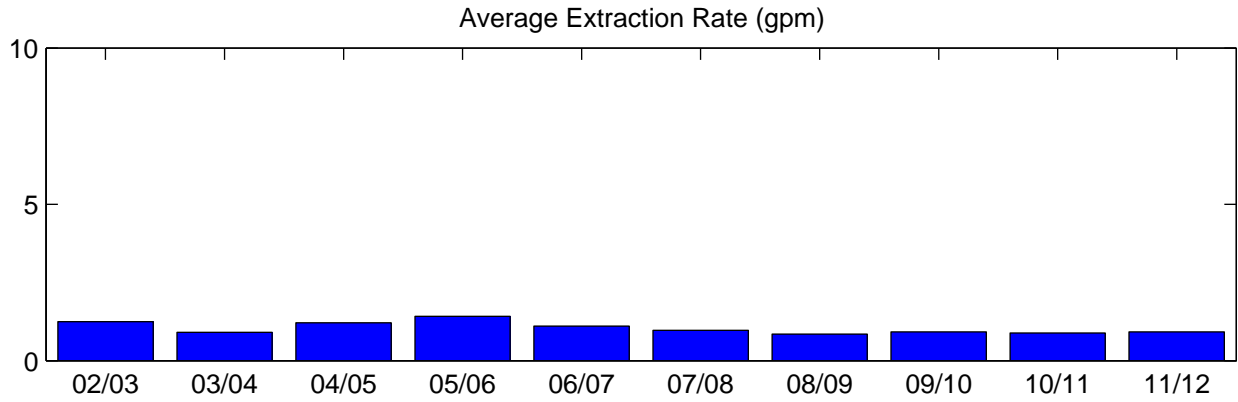
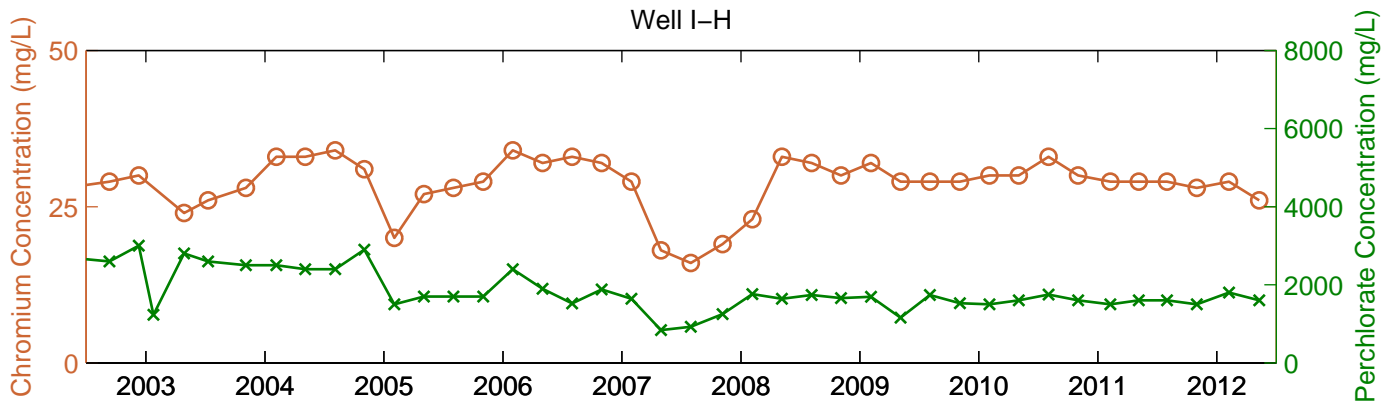

* Extraction rates for FY02/03 are the average of discharge rates reported for December 2002 and June 2003.

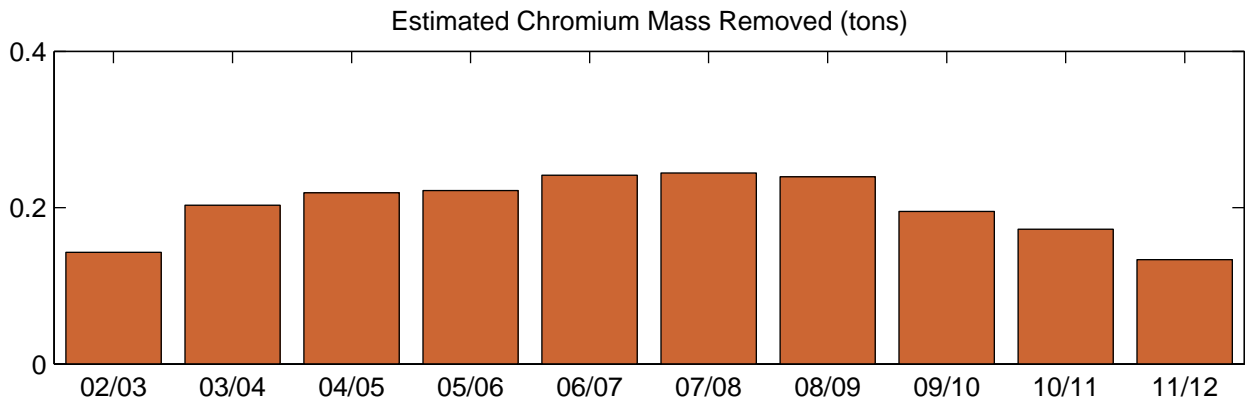
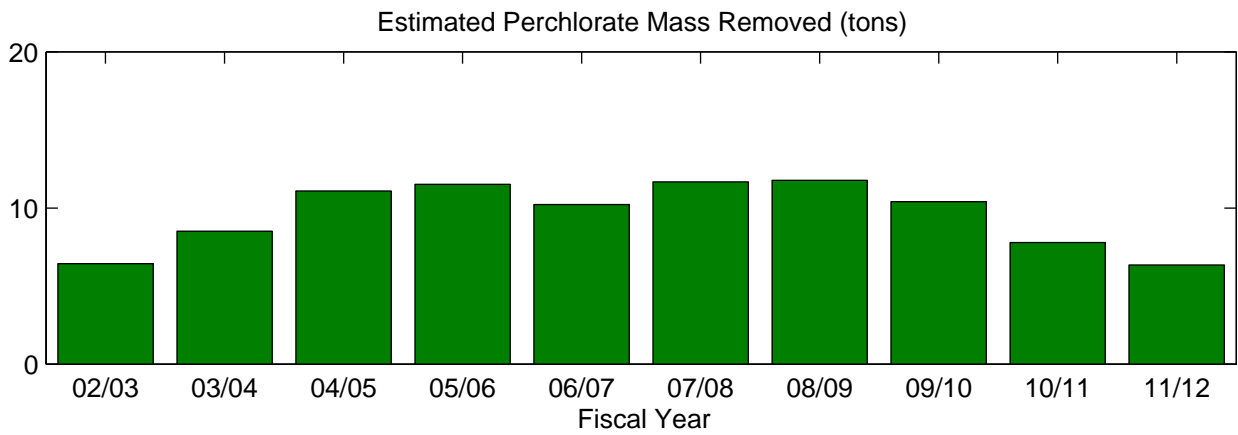
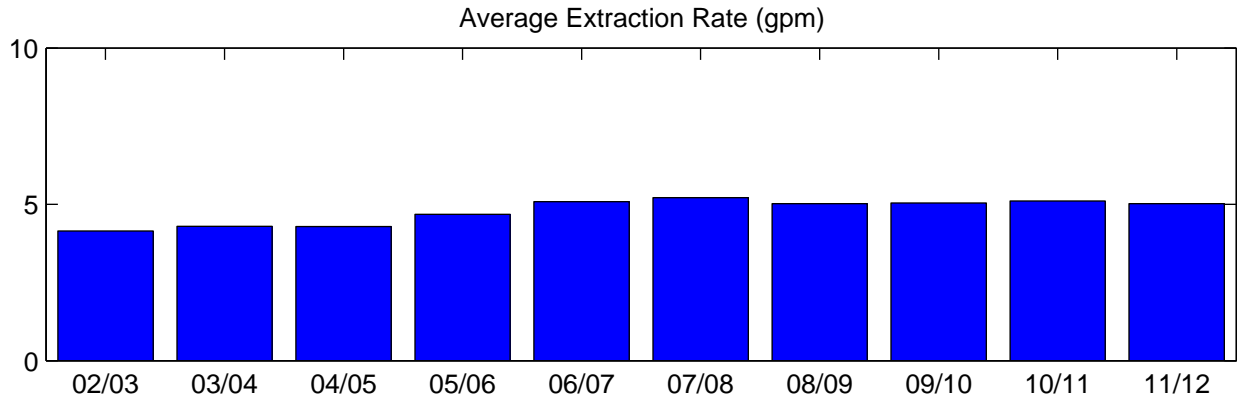
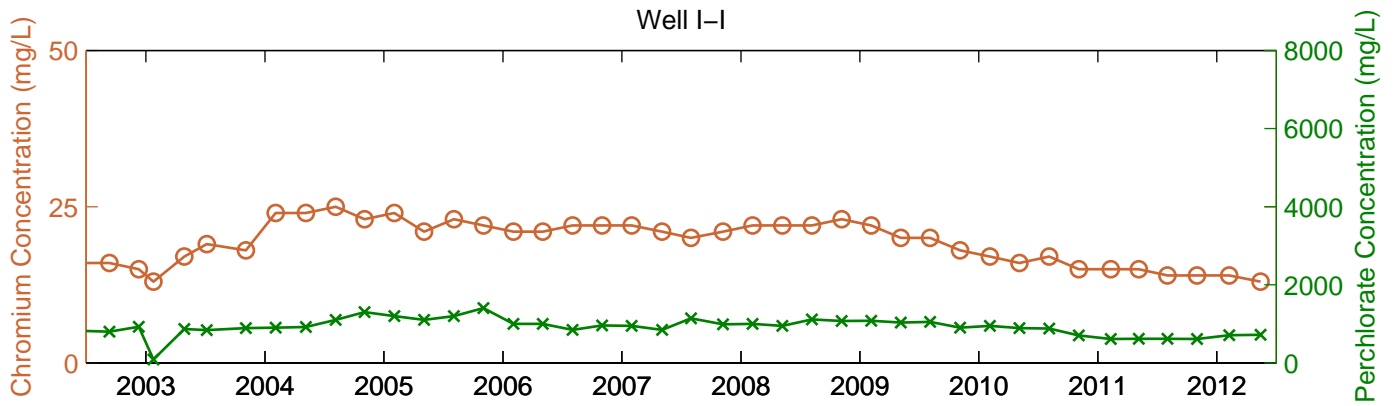

* Extraction rates for FY02/03 are the average of discharge rates reported for December 2002 and June 2003.

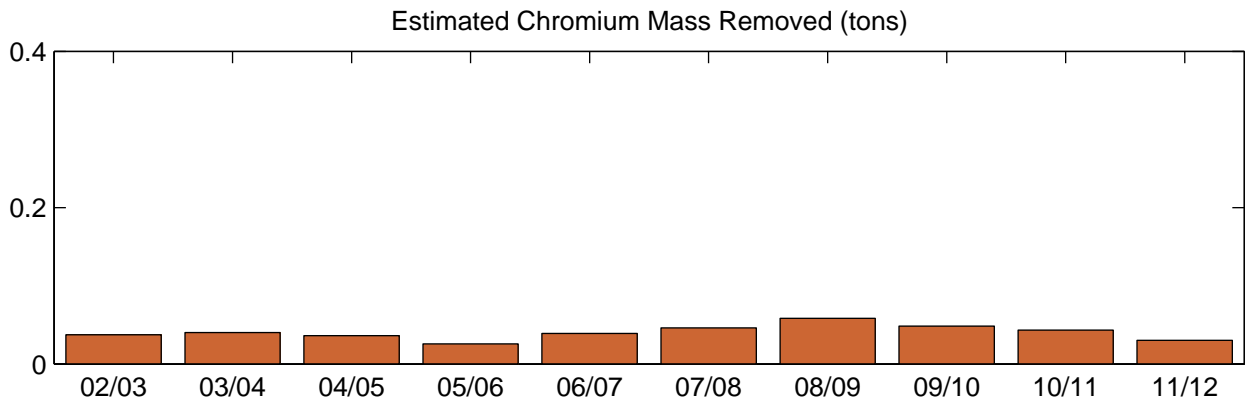
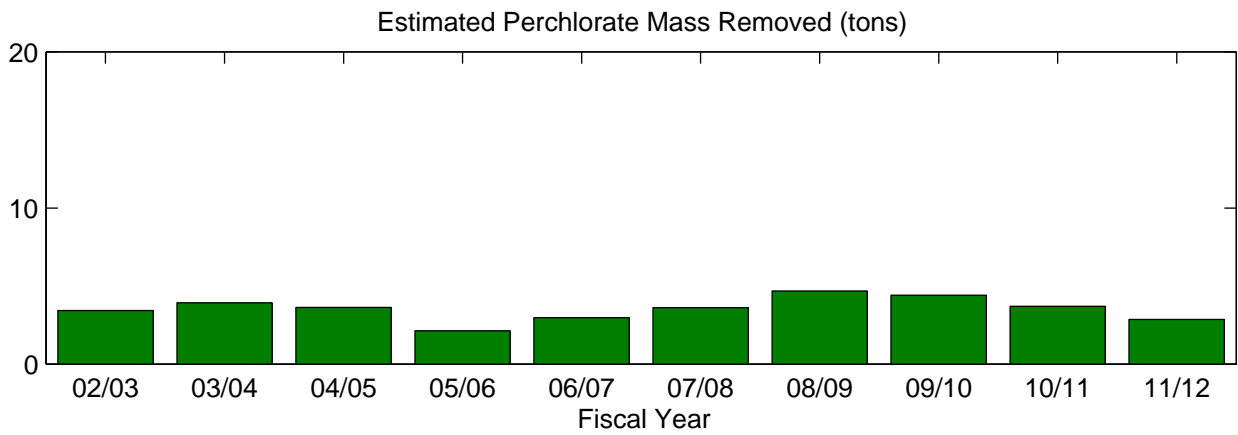
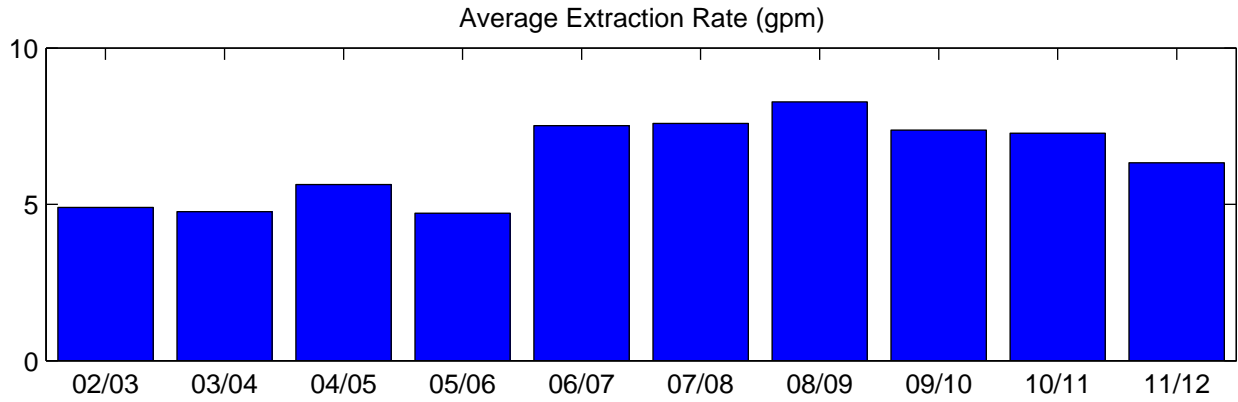
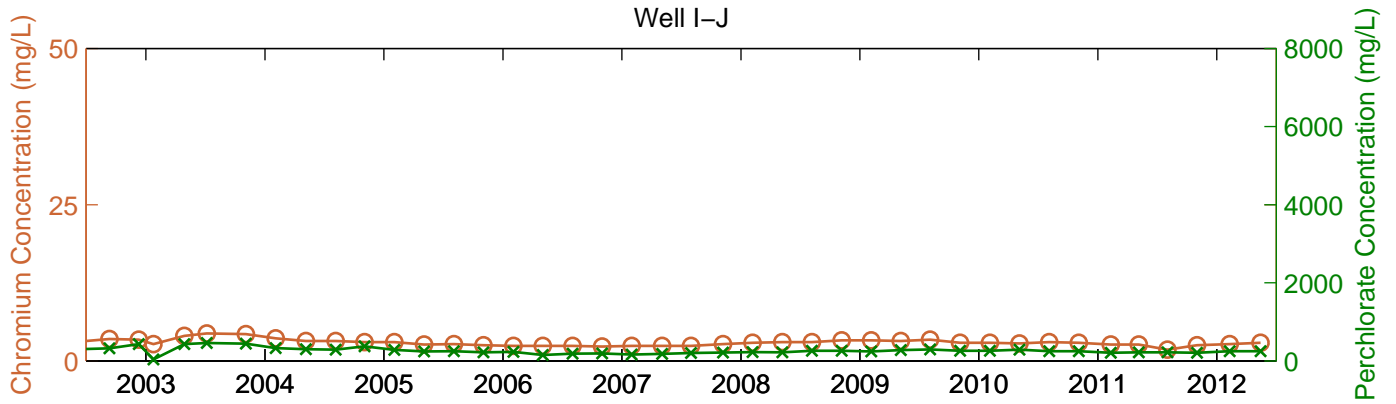

* Extraction rates for FY02/03 are the average of discharge rates reported for December 2002 and June 2003.

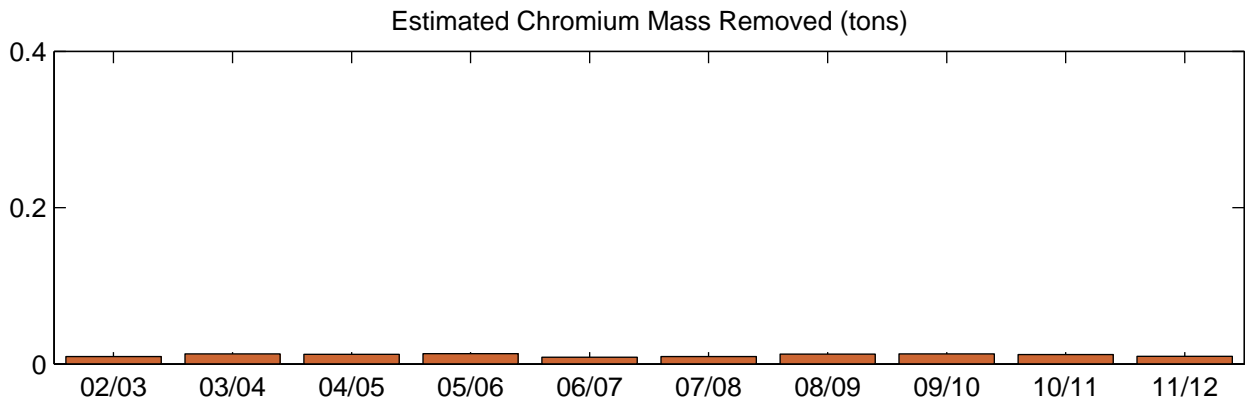
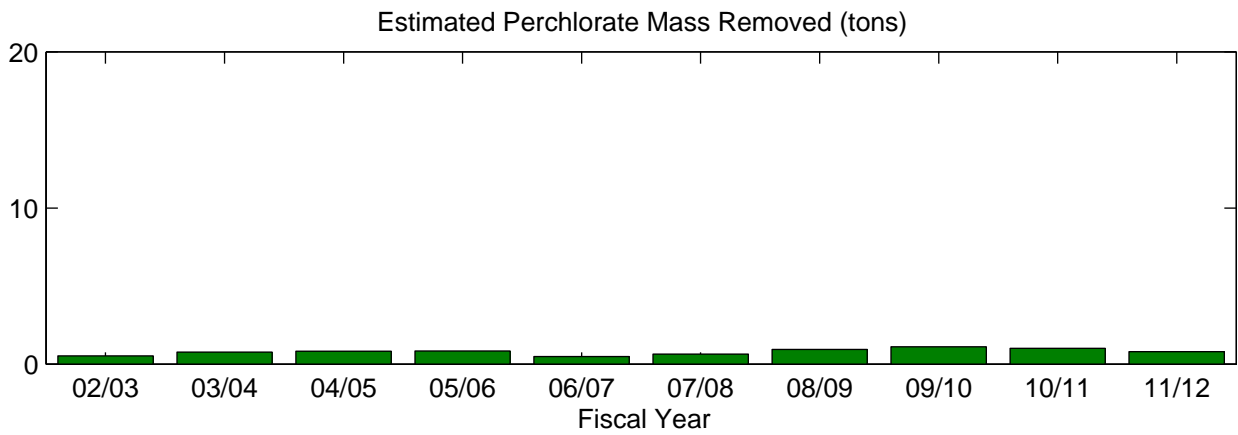
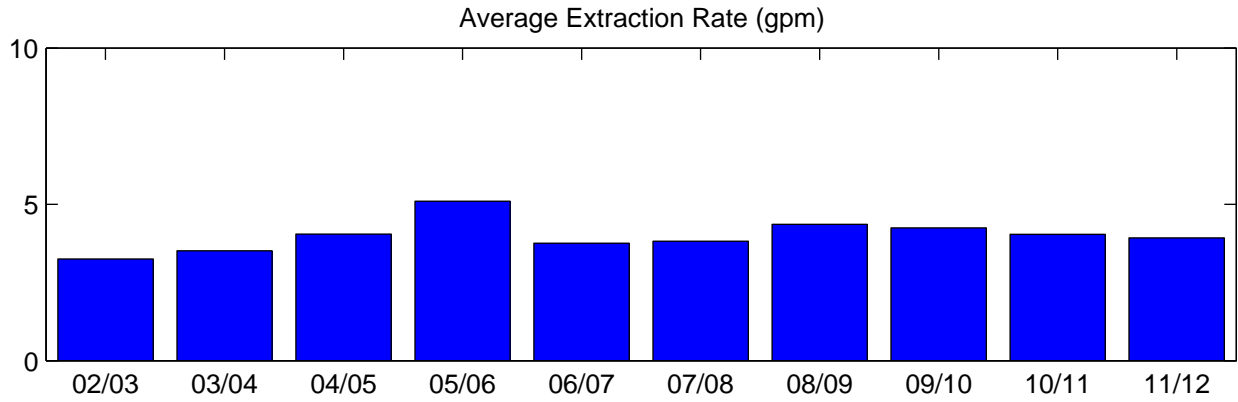
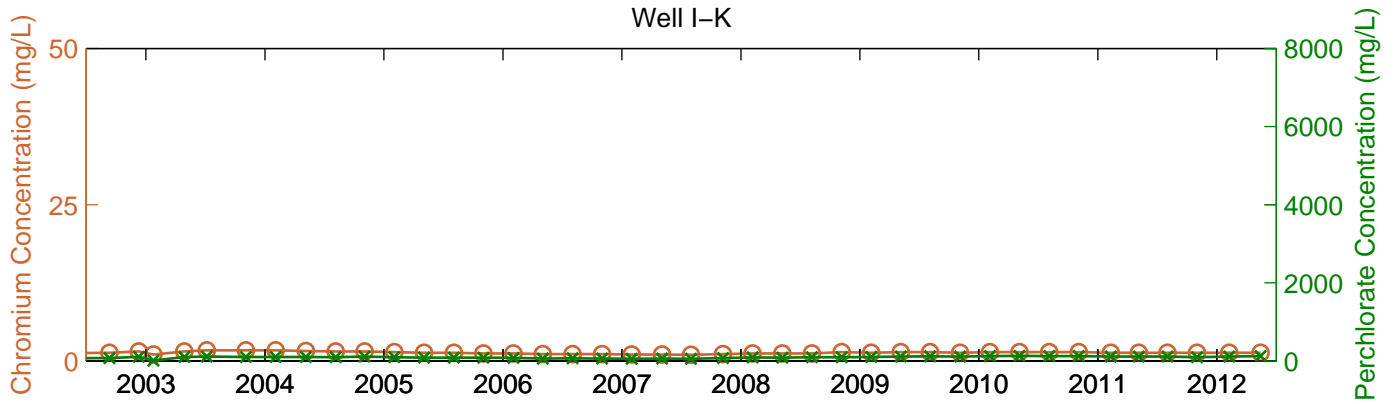

* Extraction rates for FY02/03 are the average of discharge rates reported for December 2002 and June 2003.

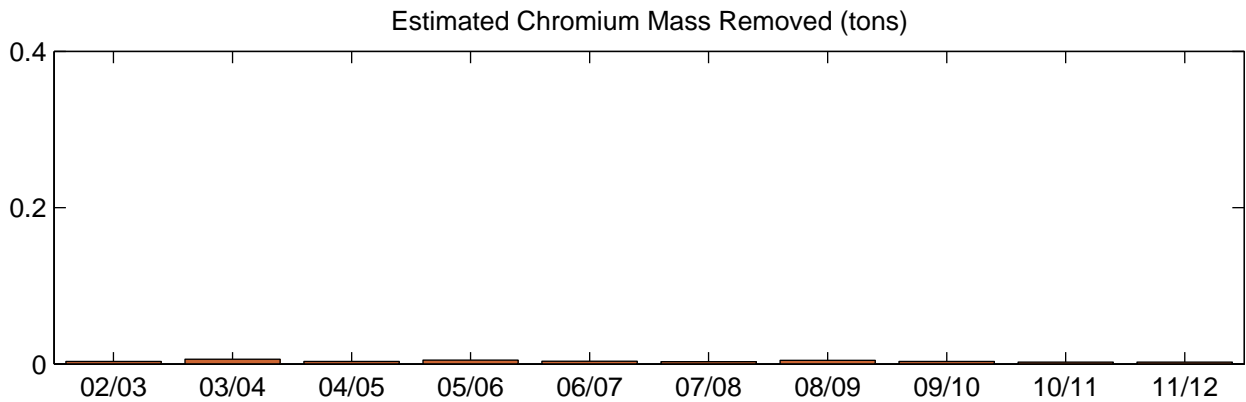
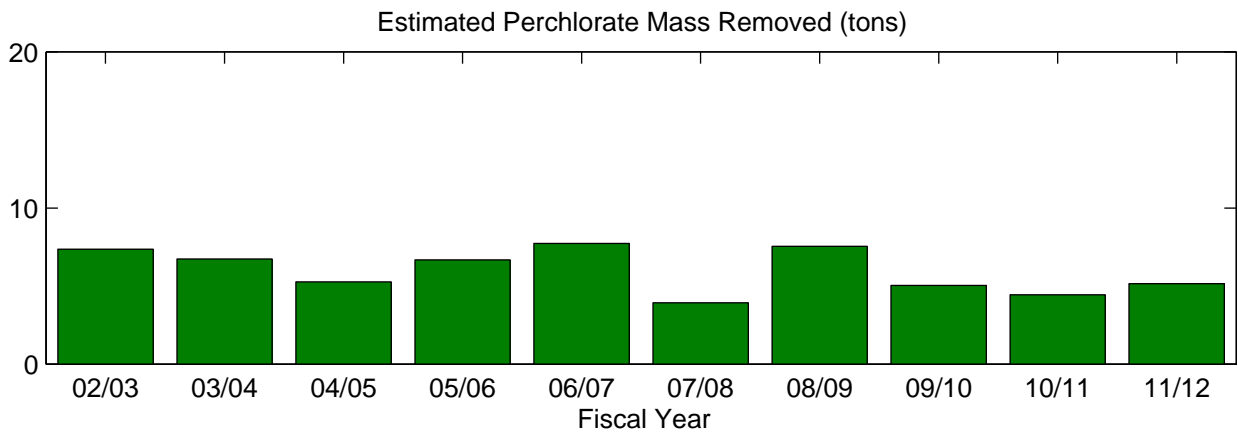
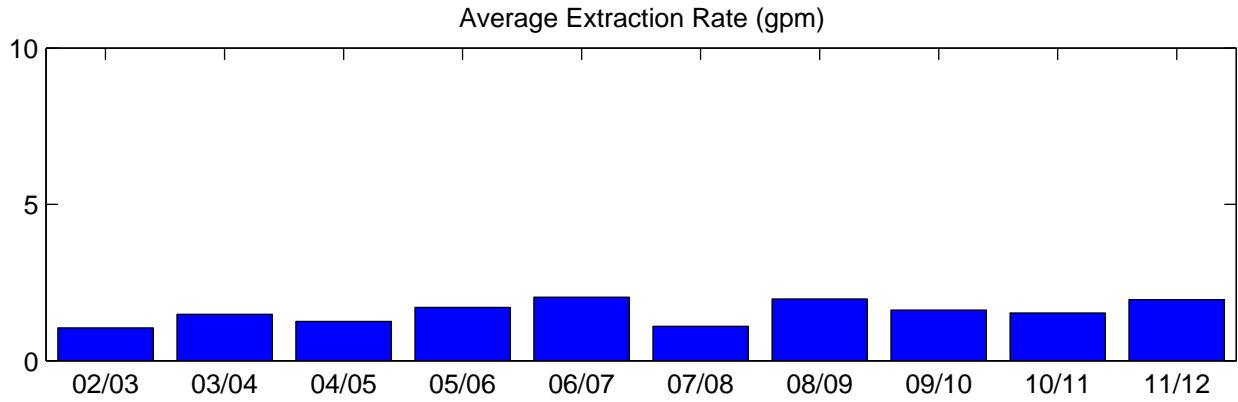
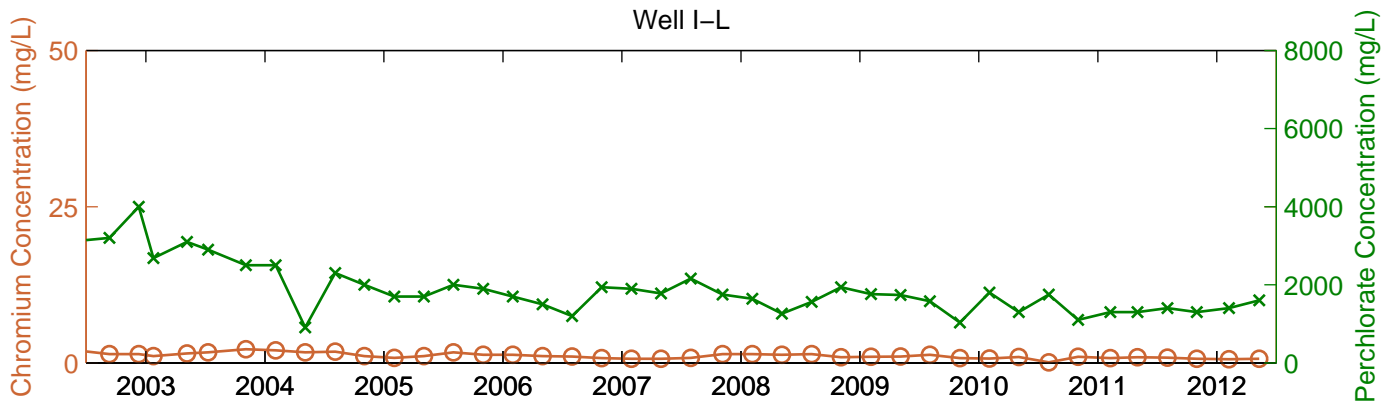

* Extraction rates for FY02/03 are the average of discharge rates reported for December 2002 and June 2003.

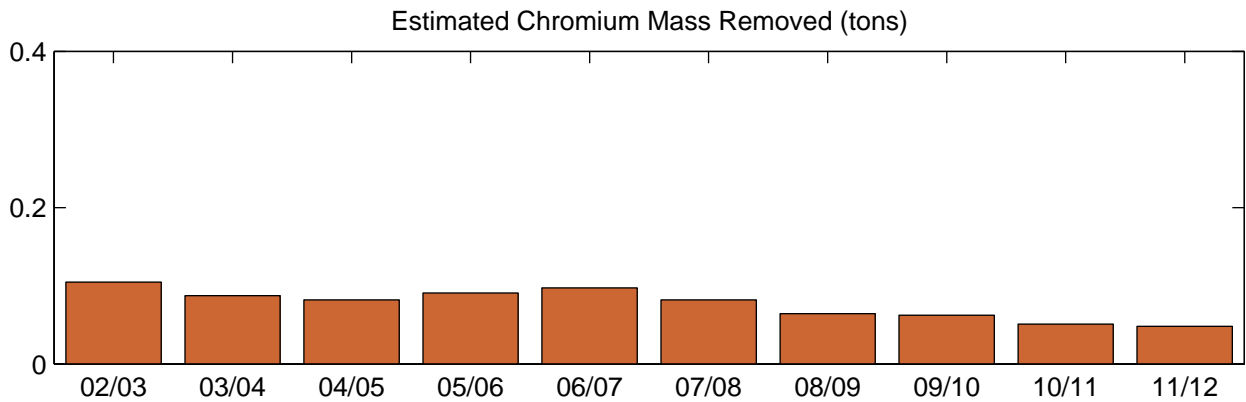
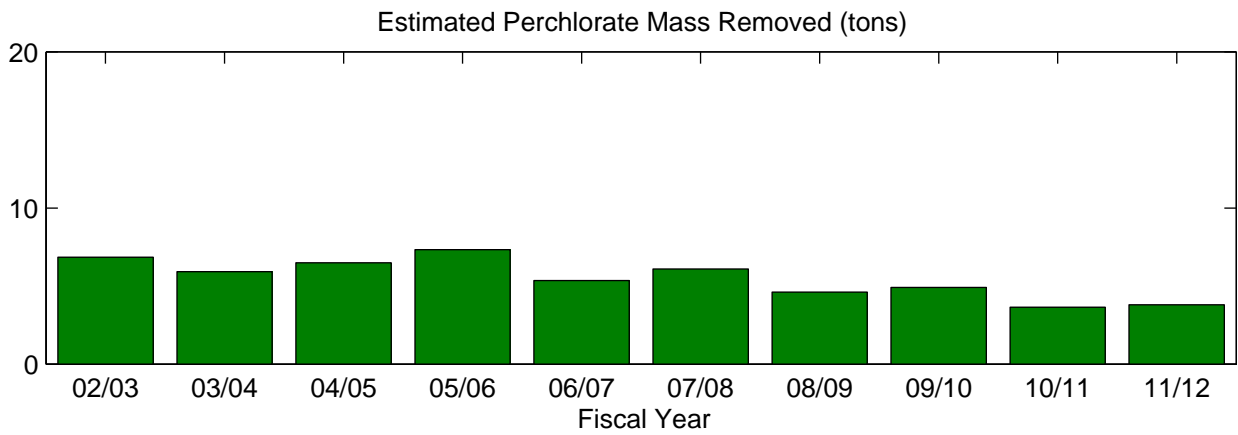
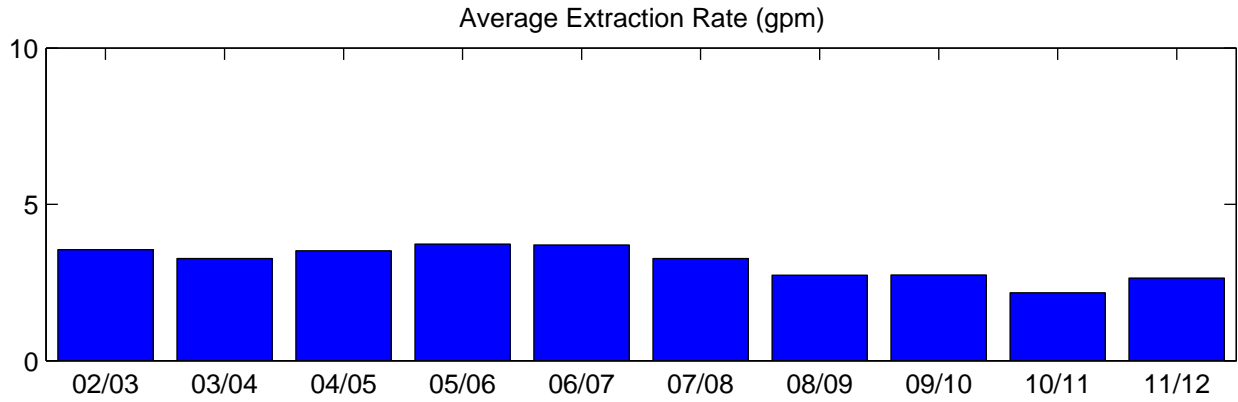
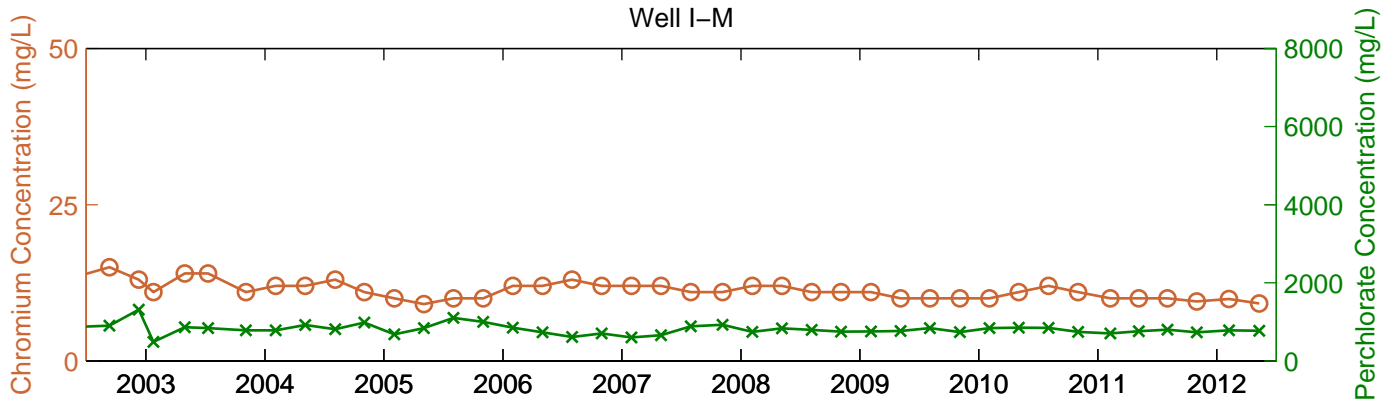

* Extraction rates for FY02/03 are the average of discharge rates reported for December 2002 and June 2003.

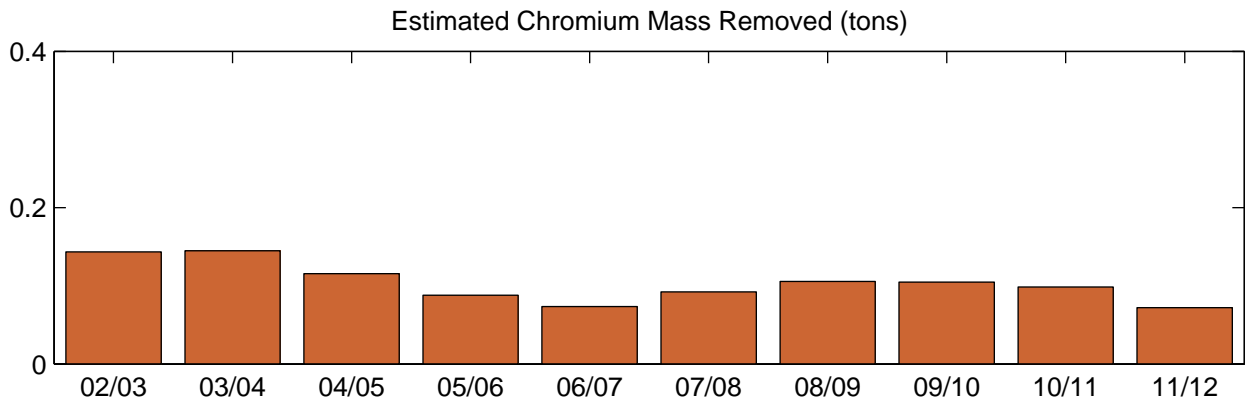
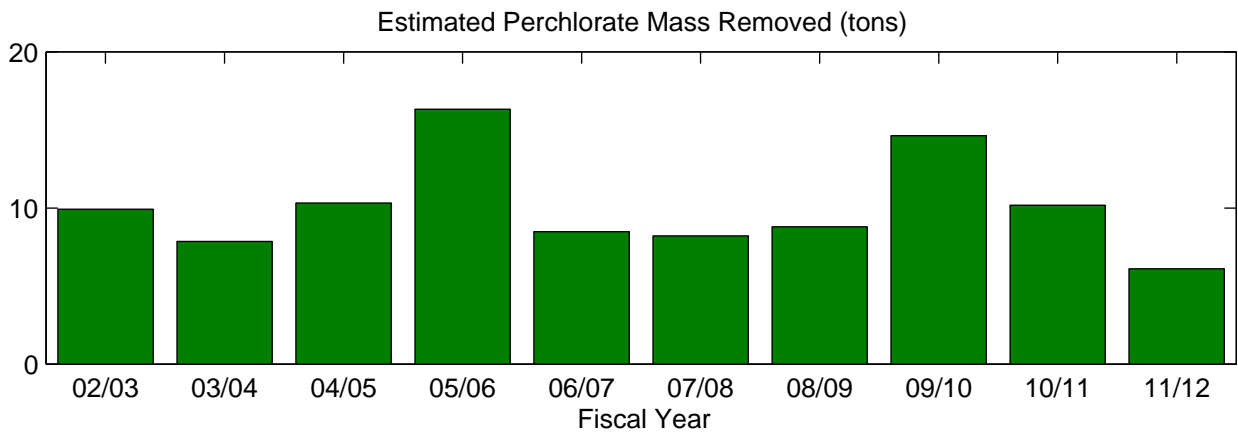
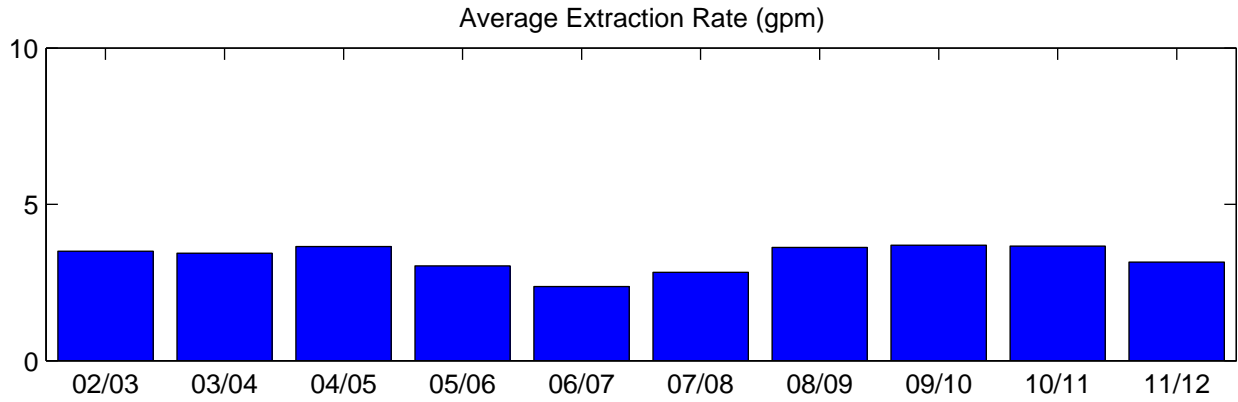
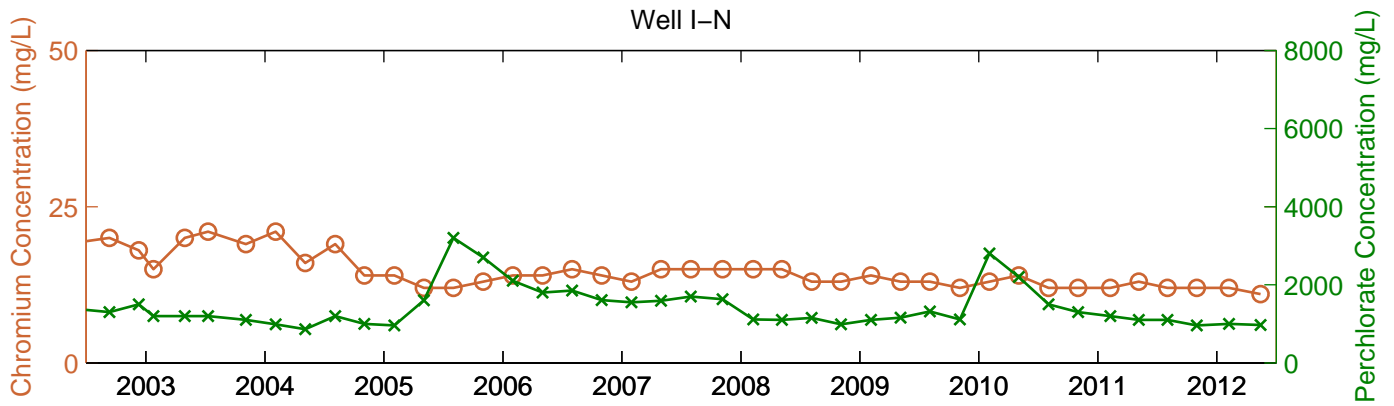

* Extraction rates for FY02/03 are the average of discharge rates reported for December 2002 and June 2003.

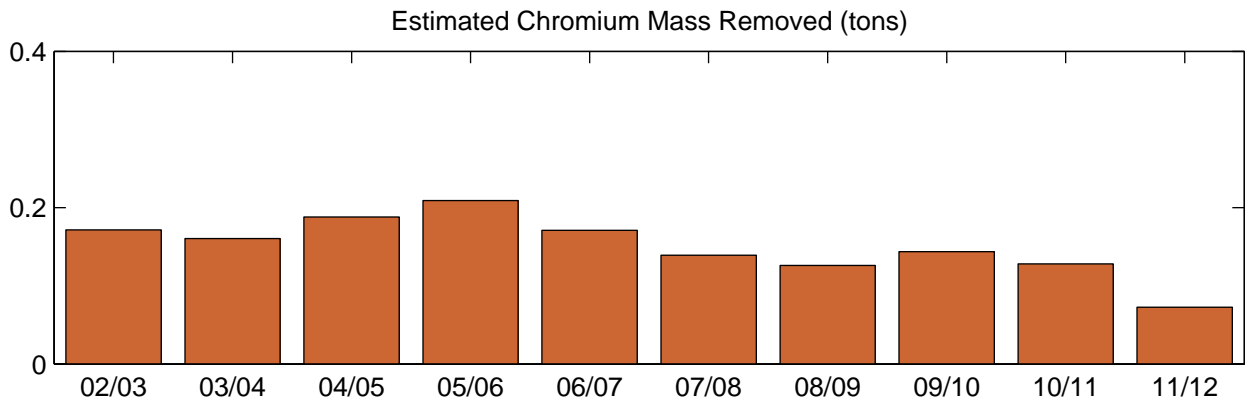
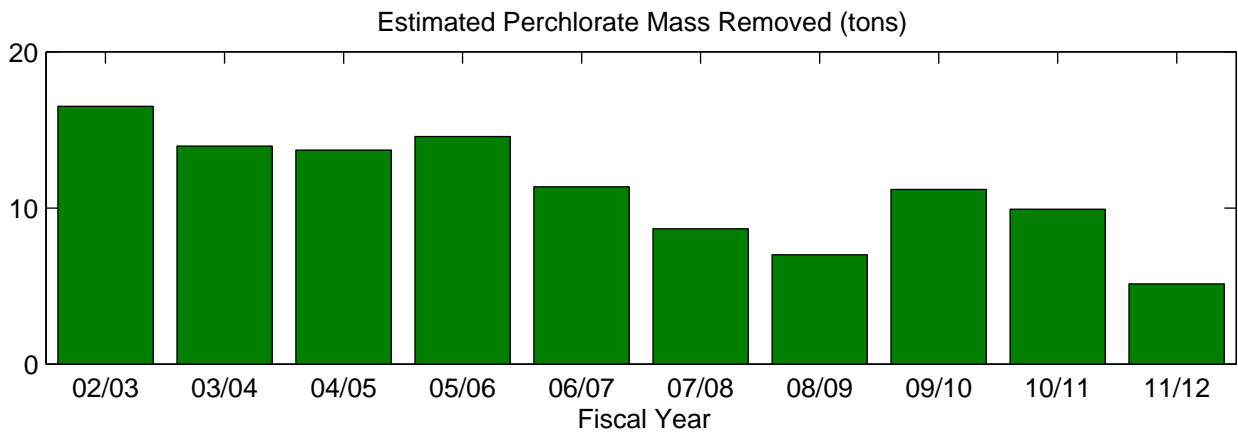
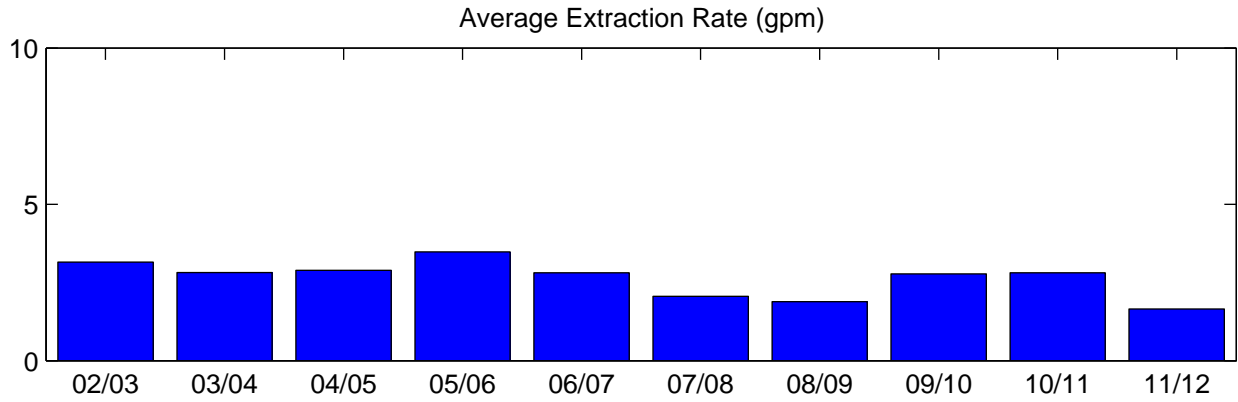
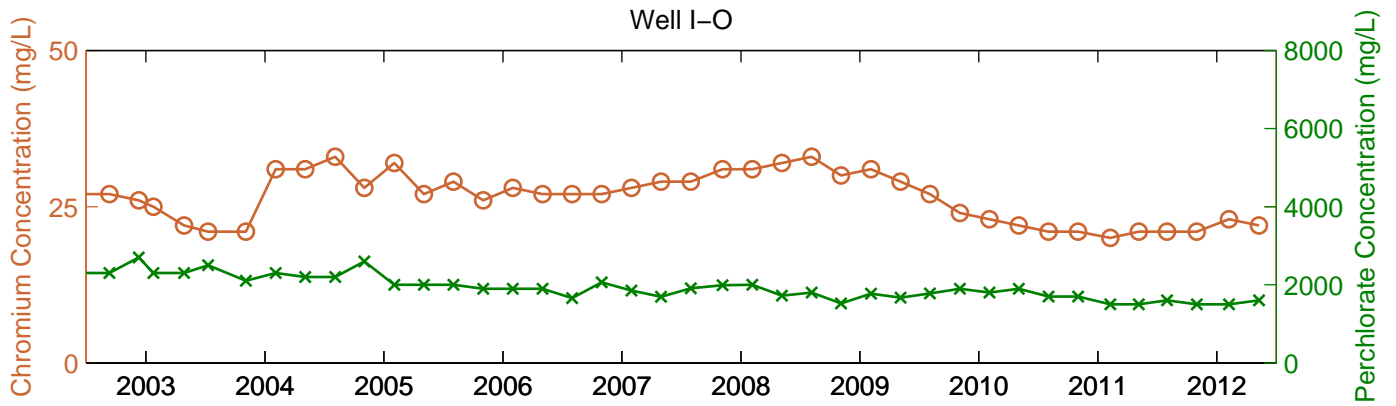

* Extraction rates for FY02/03 are the average of discharge rates reported for December 2002 and June 2003.

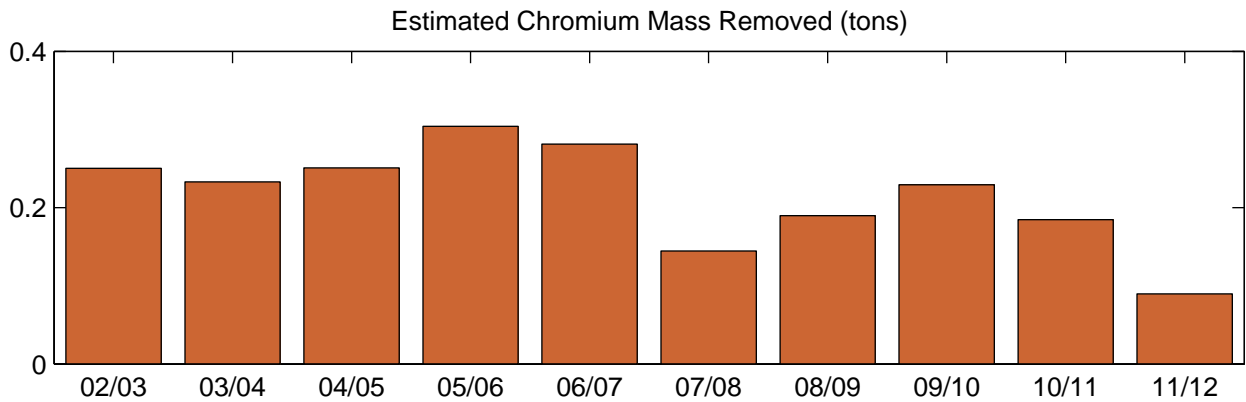
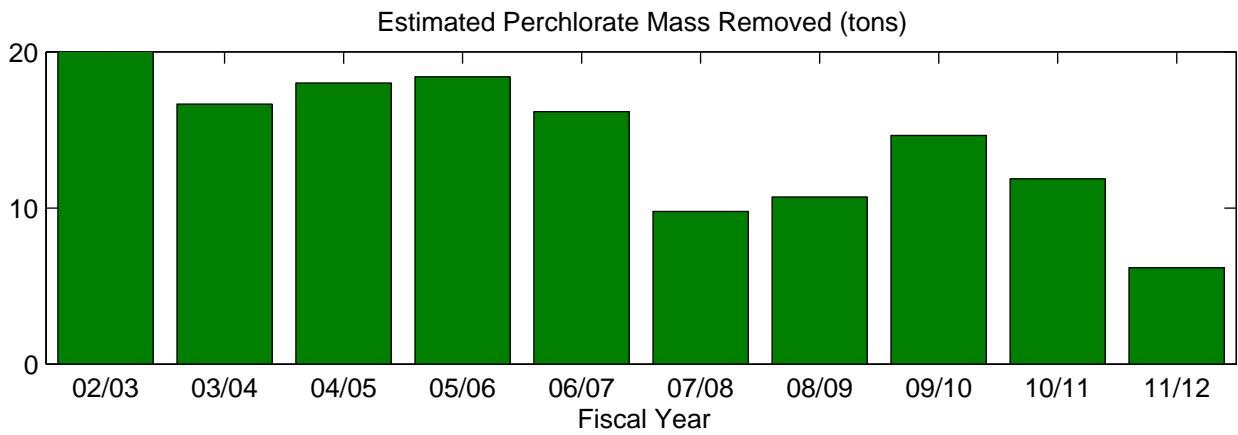
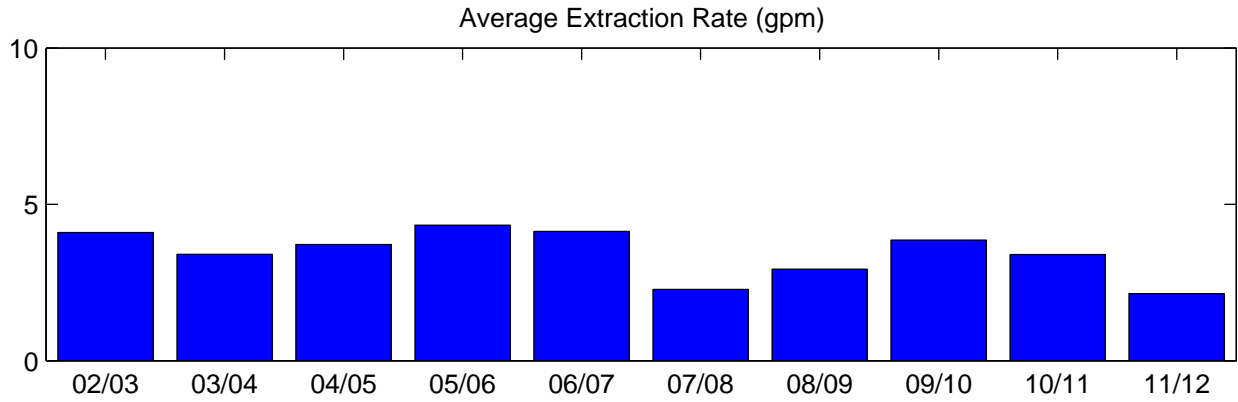
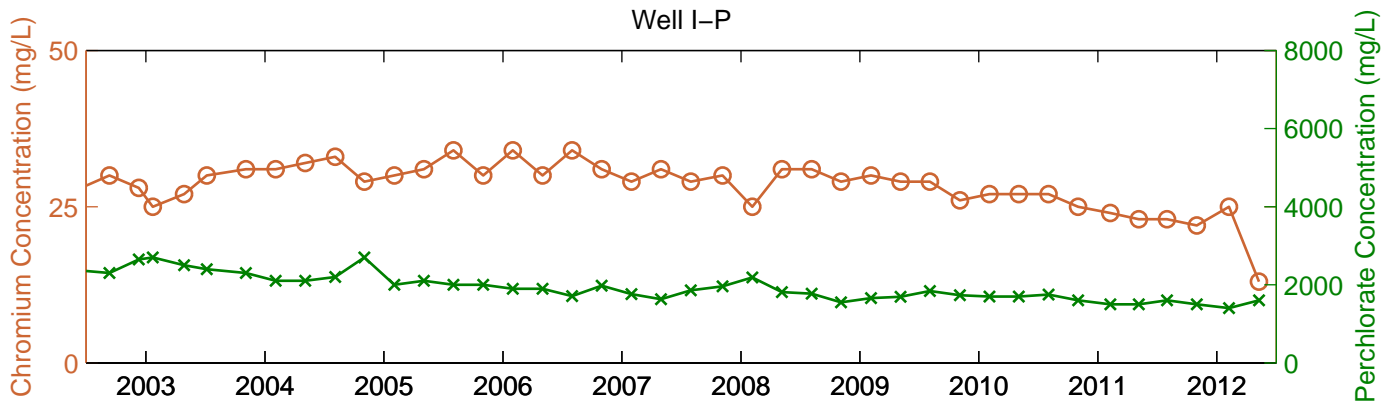

* Extraction rates for FY02/03 are the average of discharge rates reported for December 2002 and June 2003.

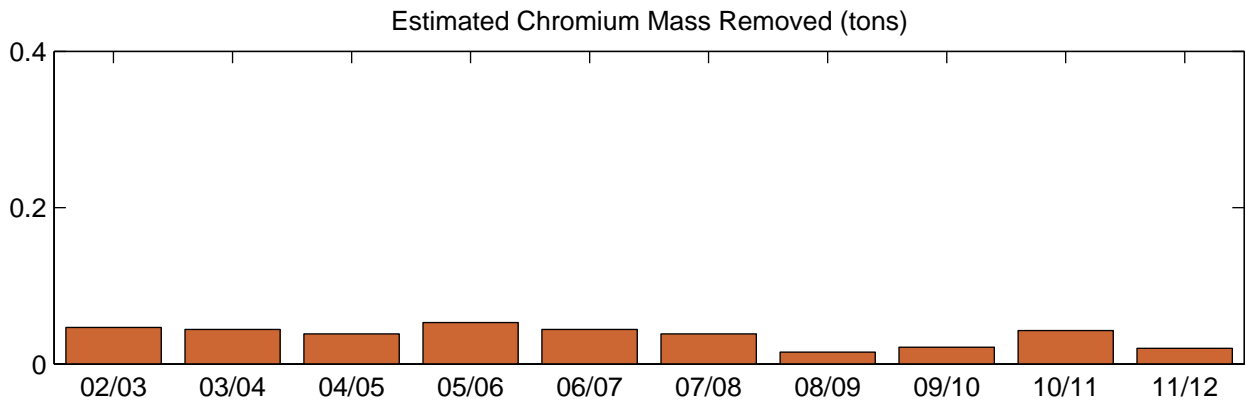
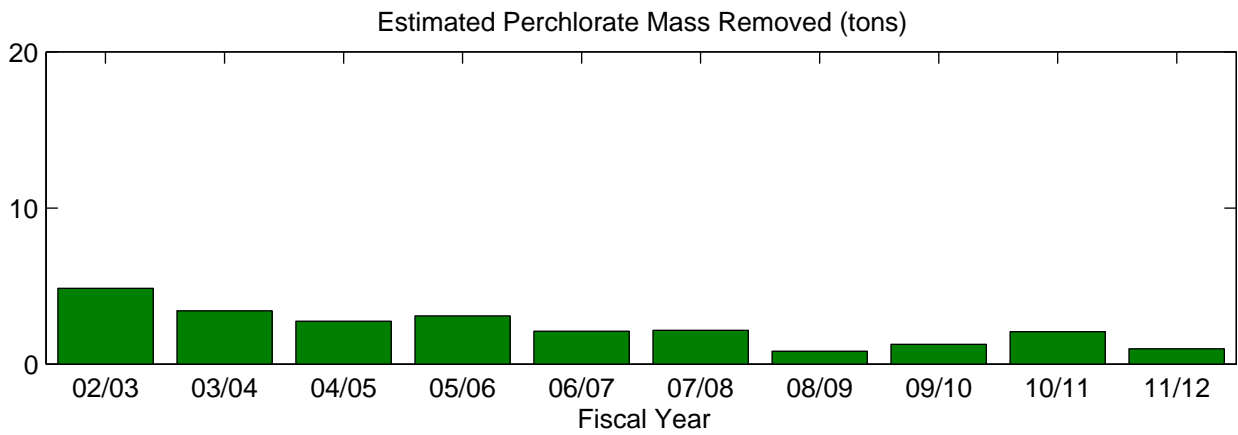
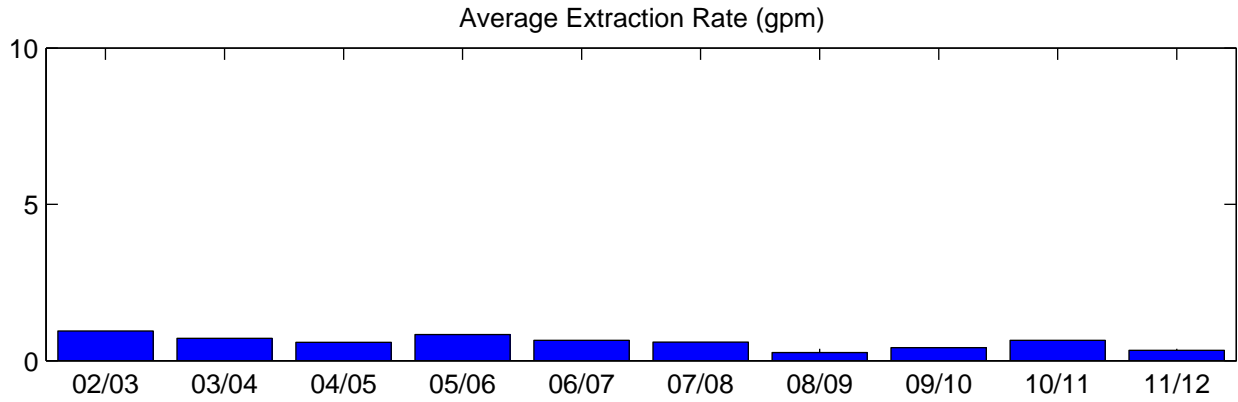
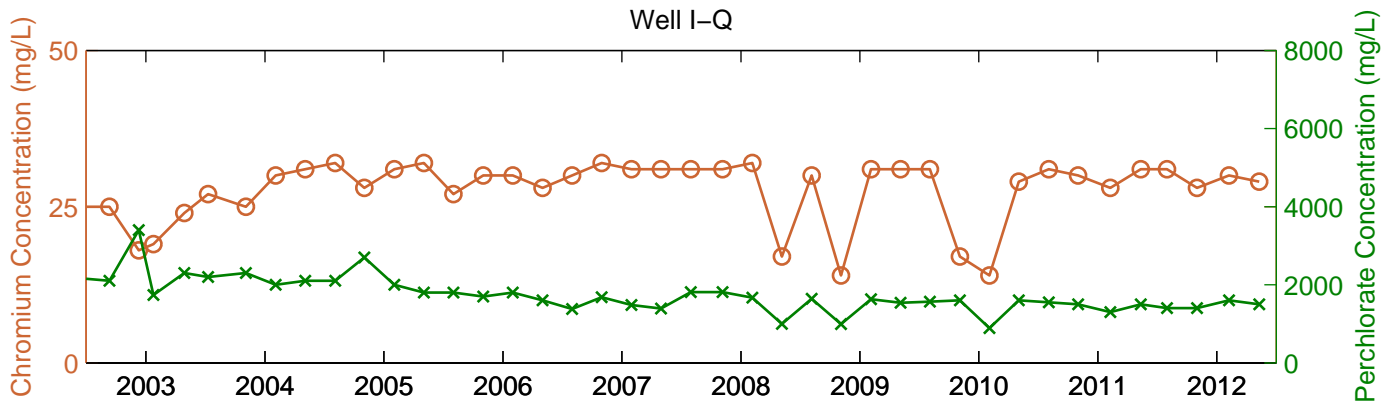

* Extraction rates for FY02/03 are the average of discharge rates reported for December 2002 and June 2003.

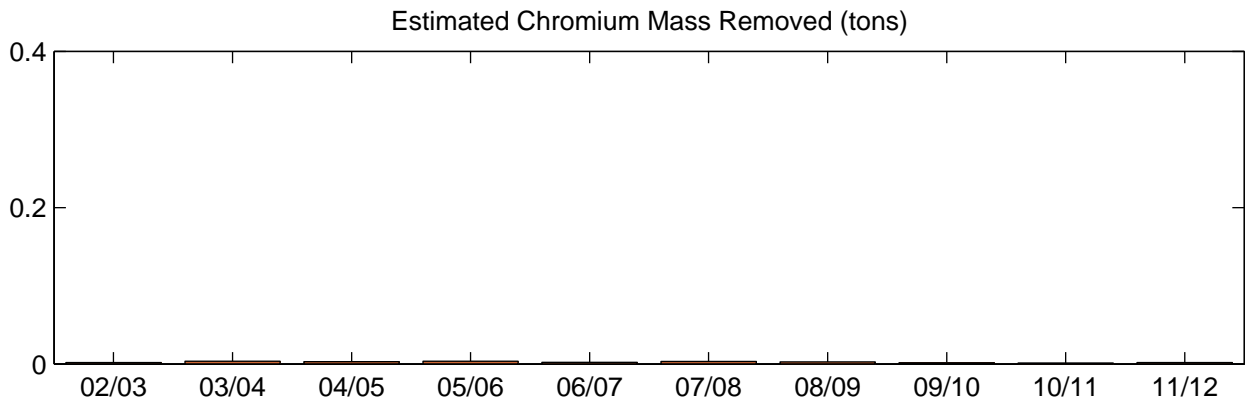
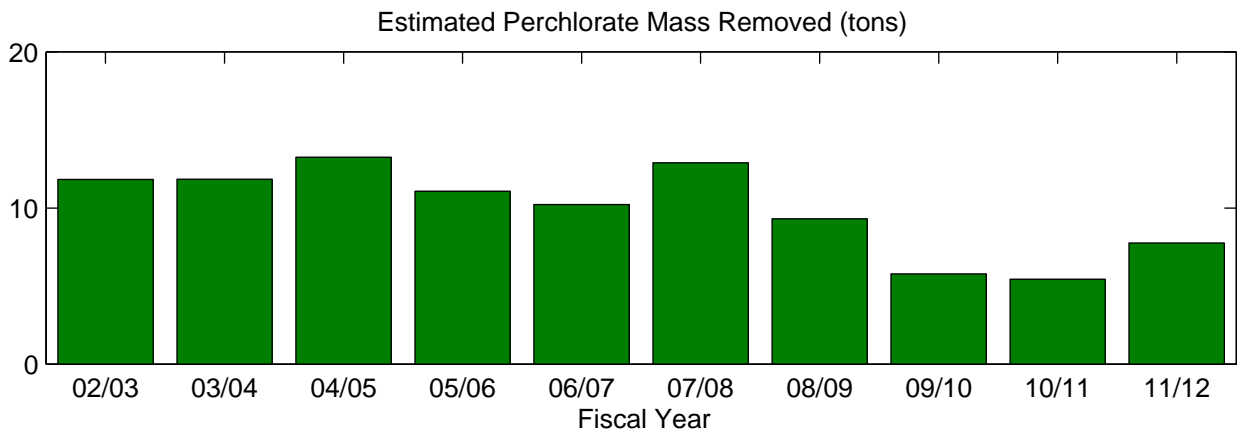
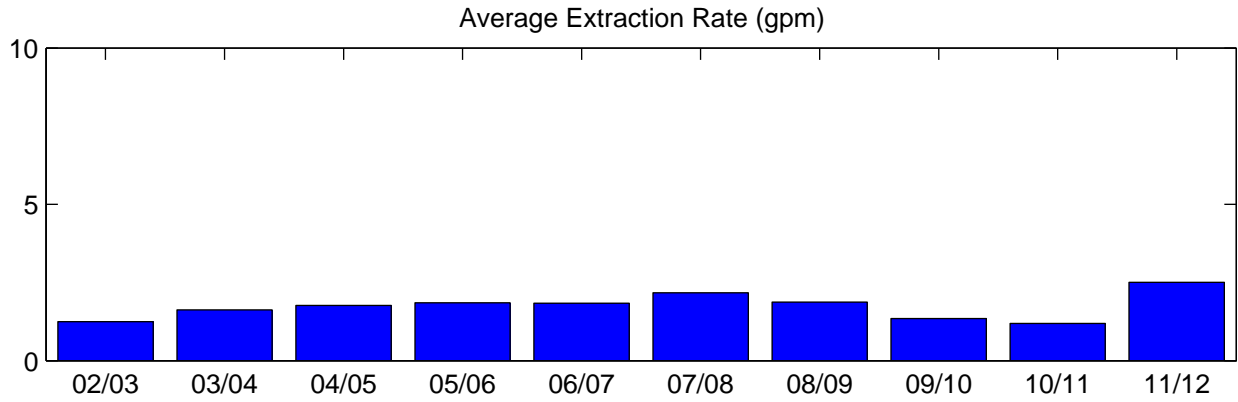
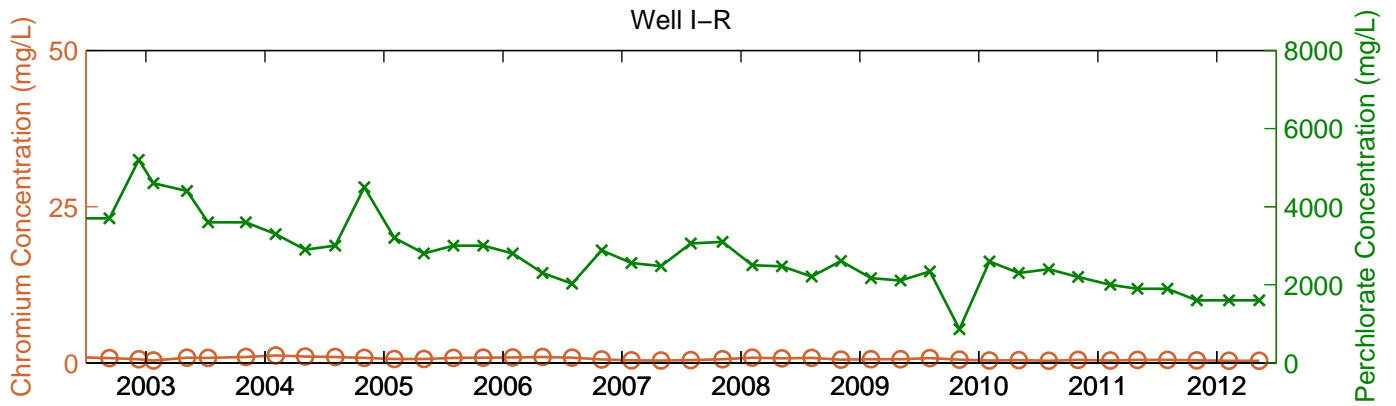

* Extraction rates for FY02/03 are the average of discharge rates reported for December 2002 and June 2003.

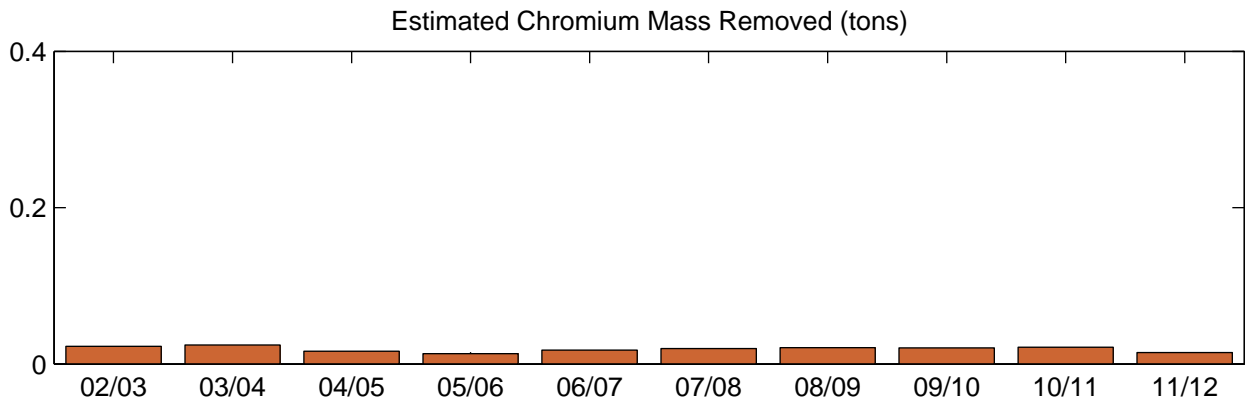
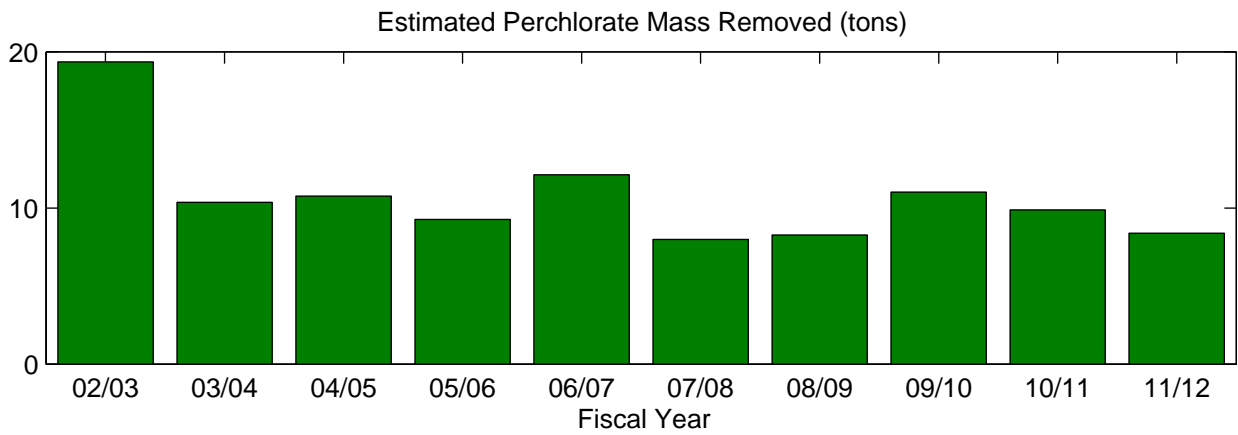
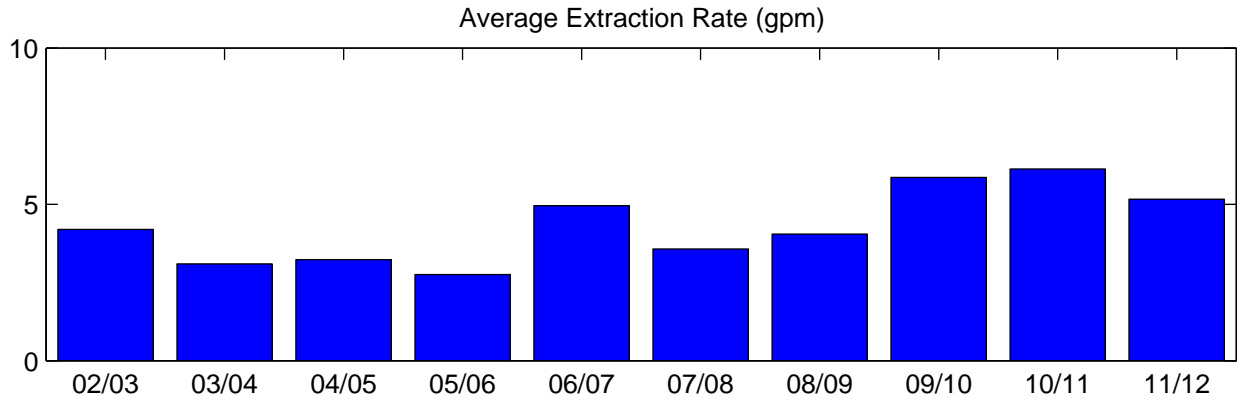
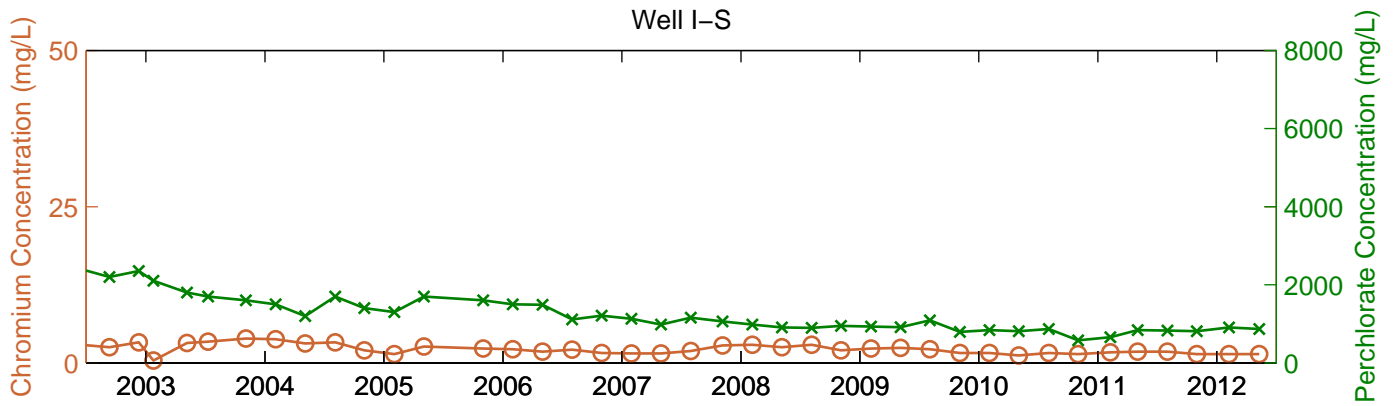

* Extraction rates for FY02/03 are the average of discharge rates reported for December 2002 and June 2003.

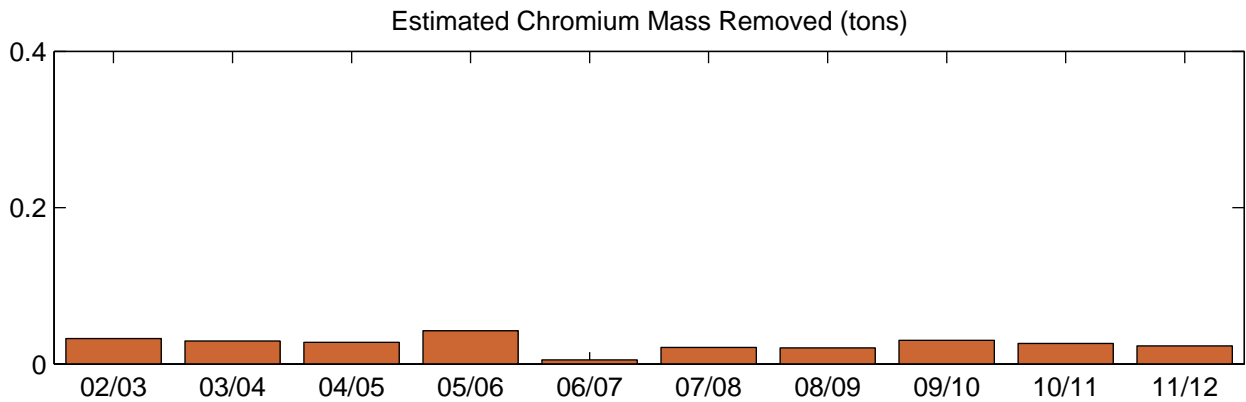
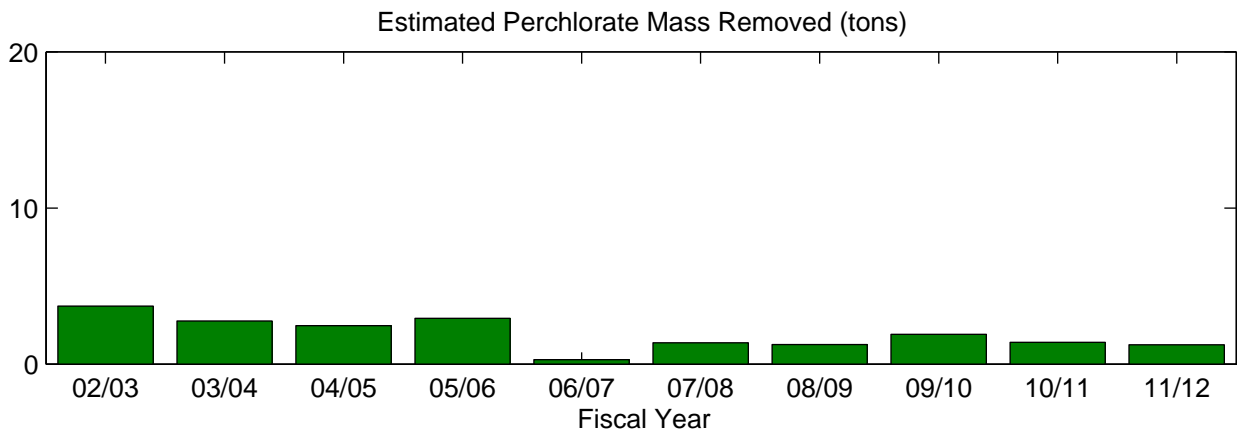
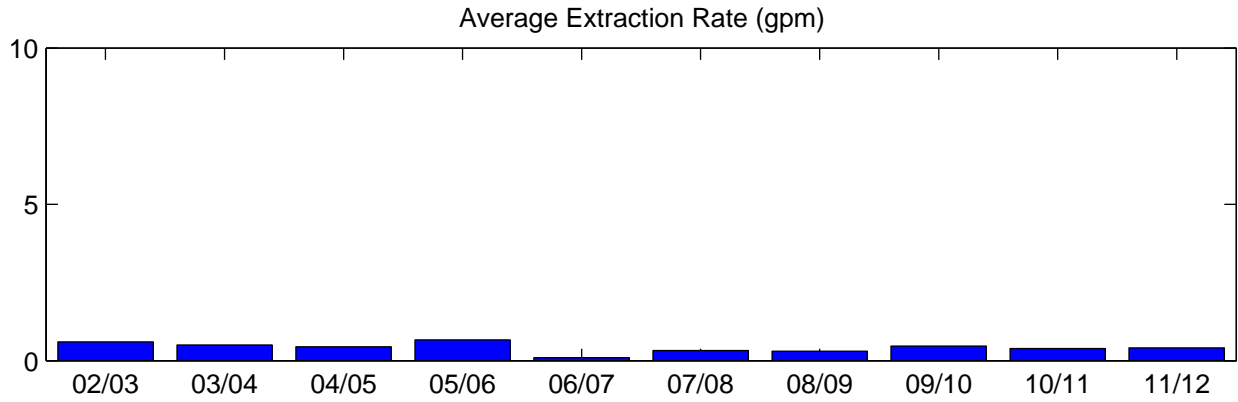
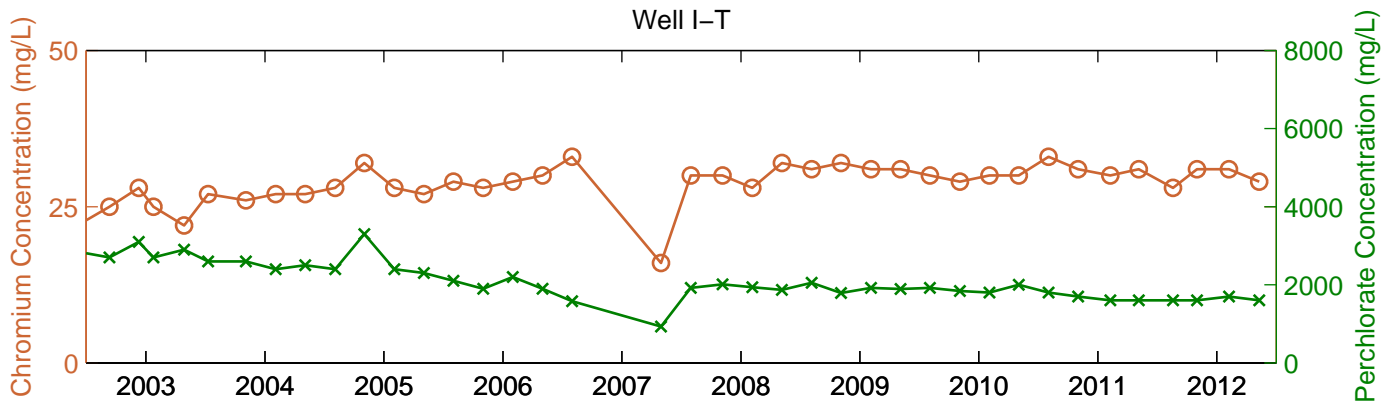

* Extraction rates for FY02/03 are the average of discharge rates reported for December 2002 and June 2003.

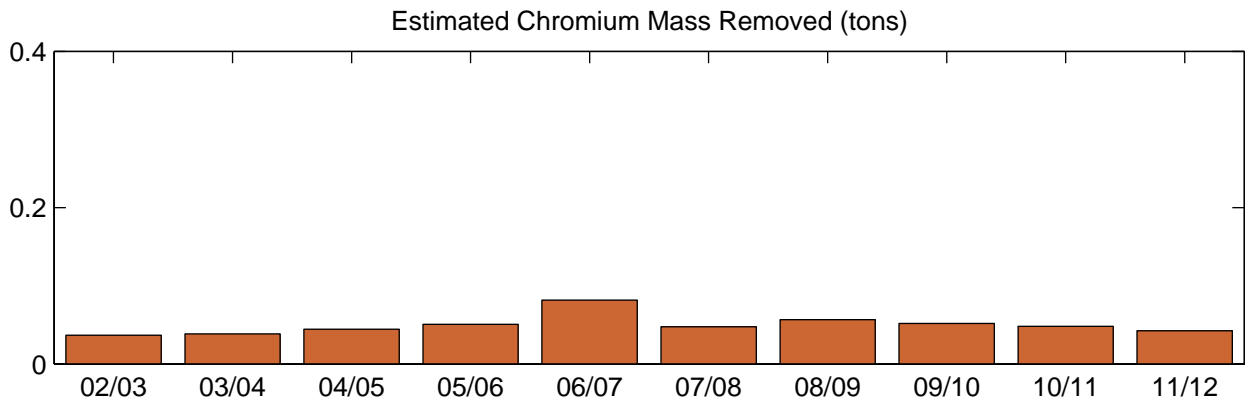
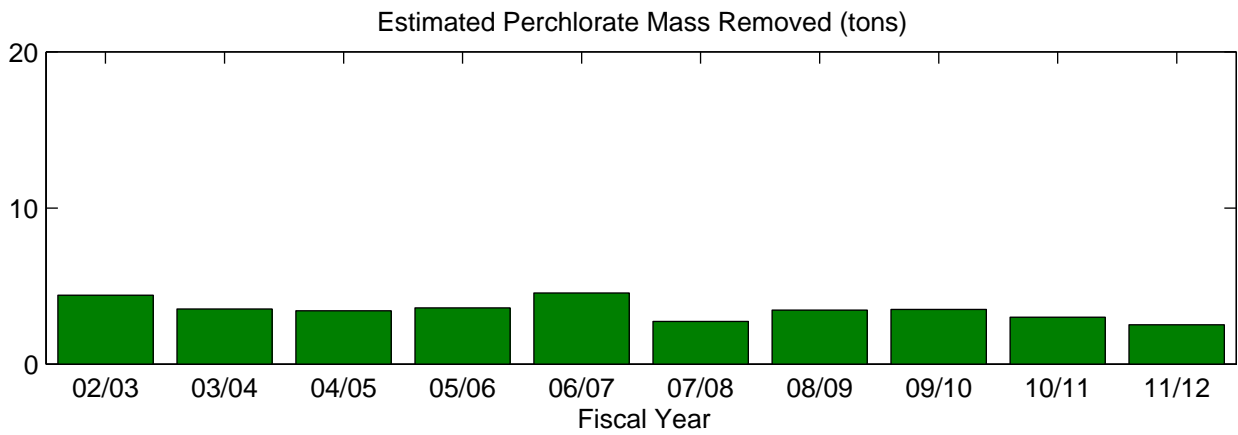
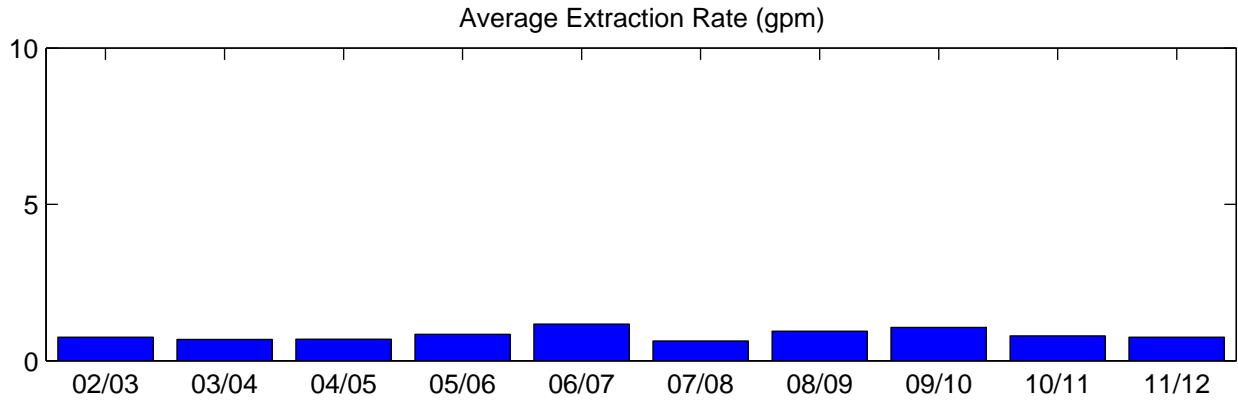
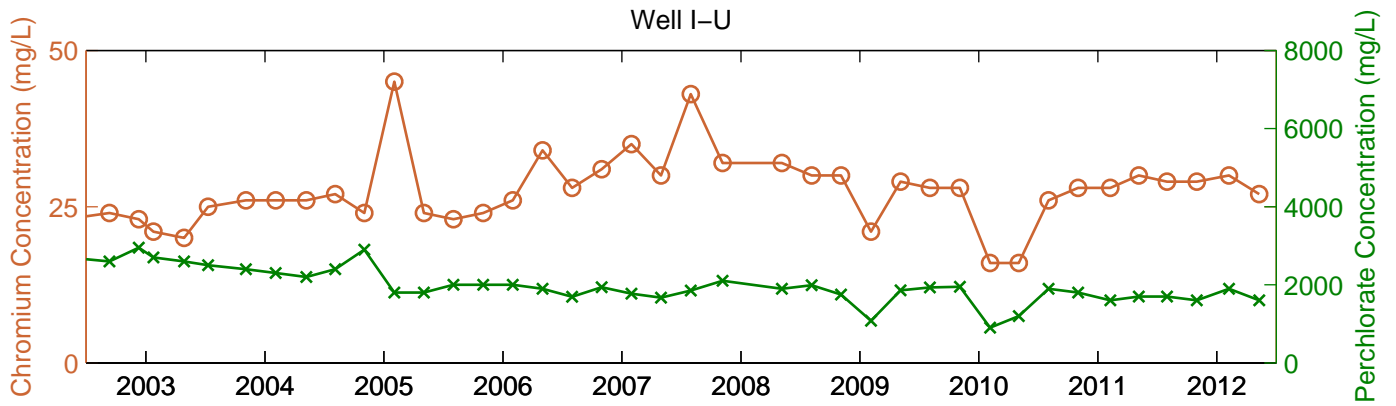

* Extraction rates for FY02/03 are the average of discharge rates reported for December 2002 and June 2003.

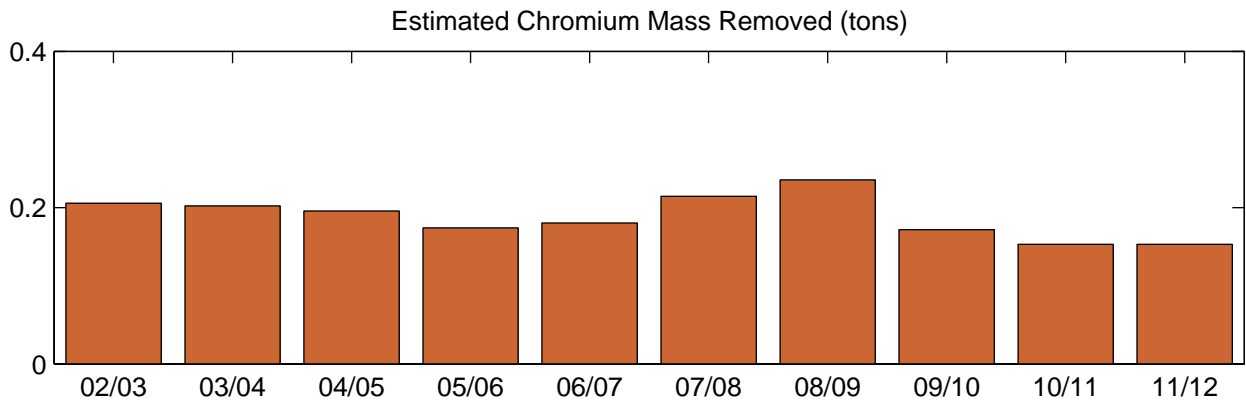
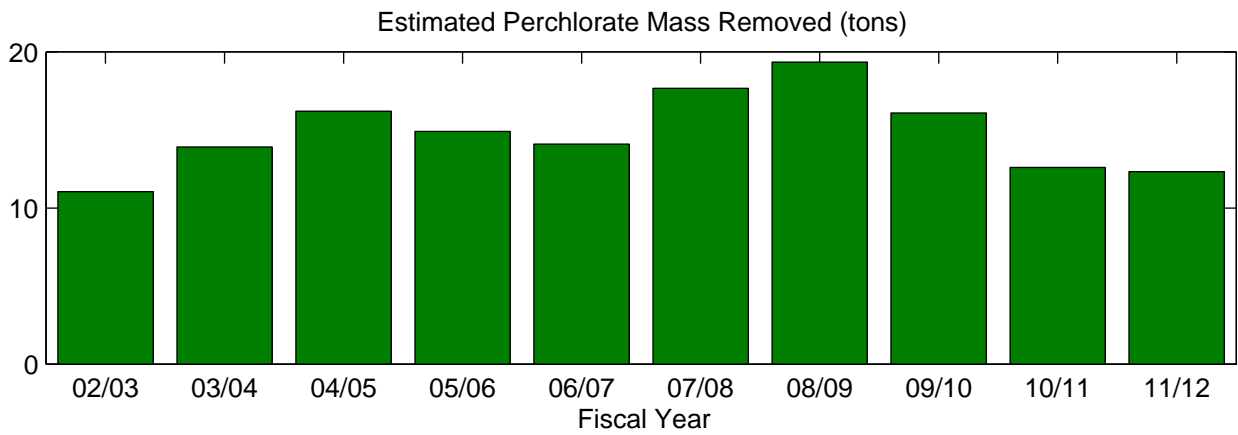
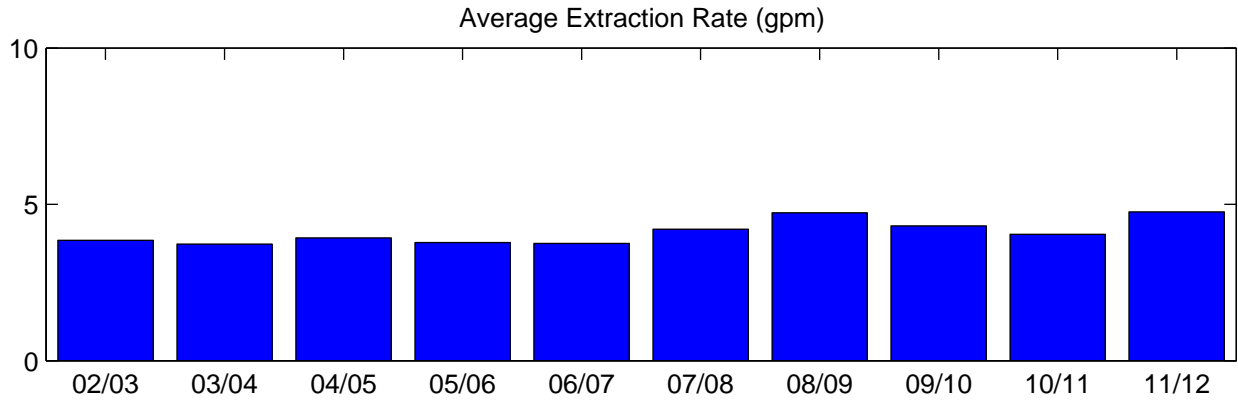
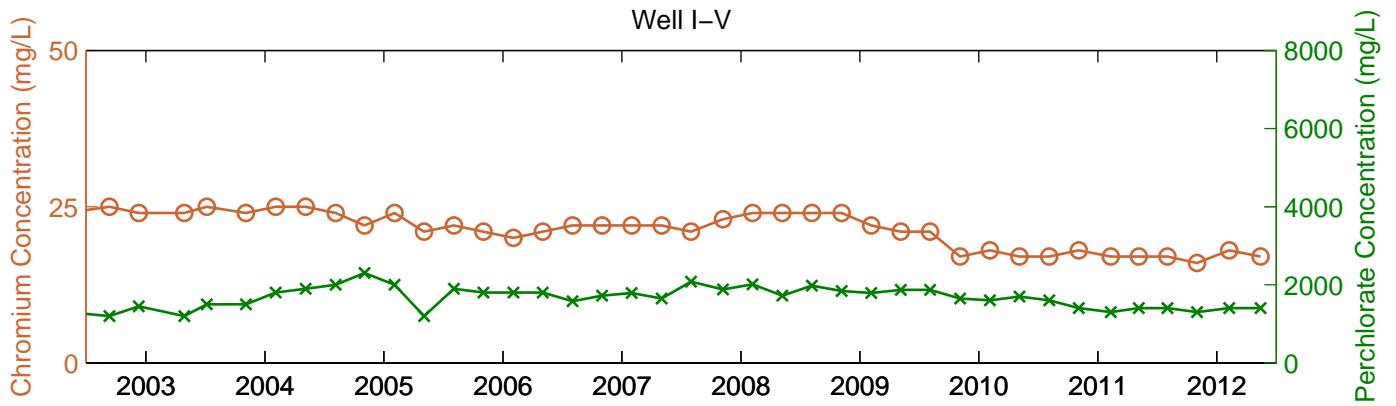

* Extraction rates for FY02/03 are the average of discharge rates reported for December 2002 and June 2003.

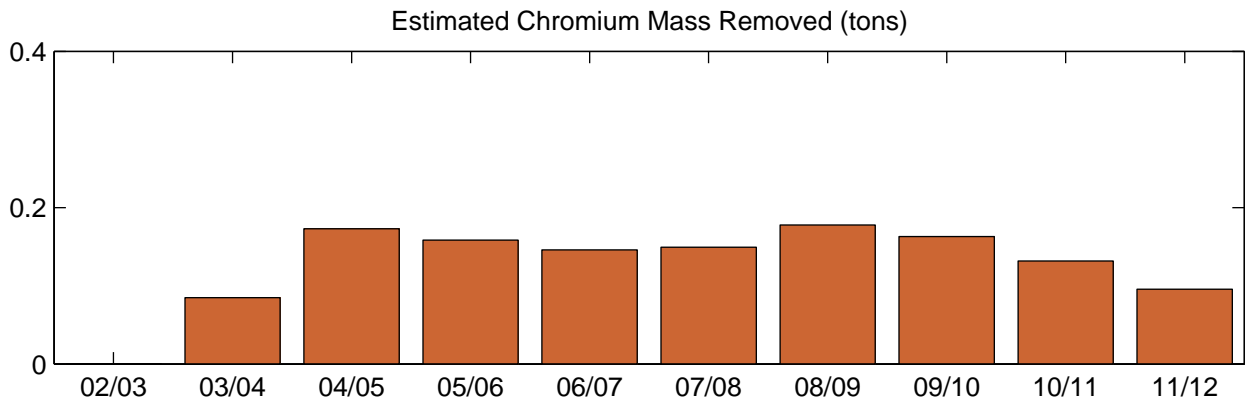
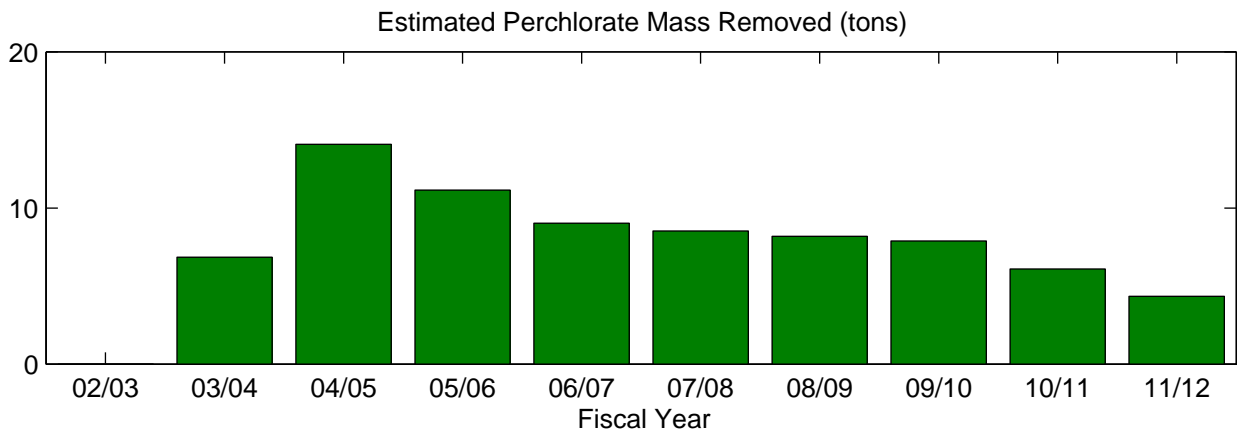
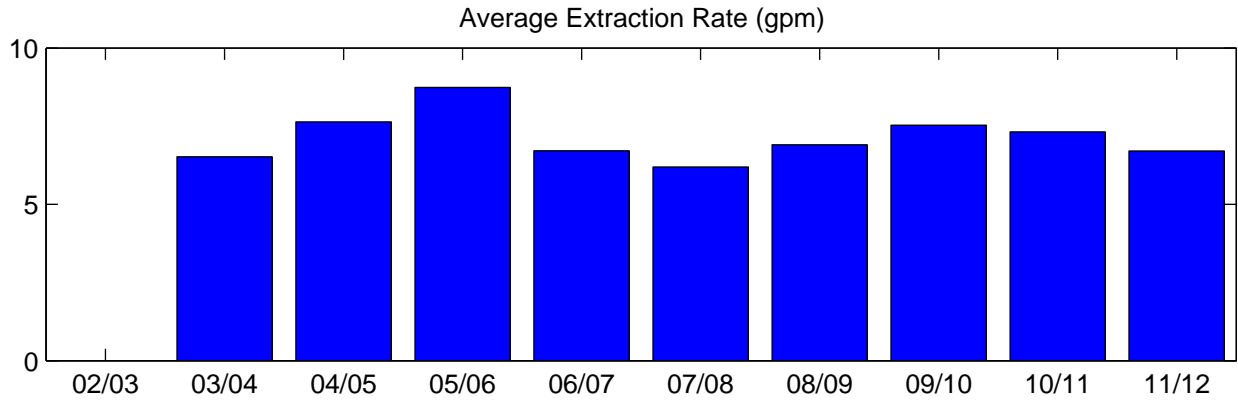
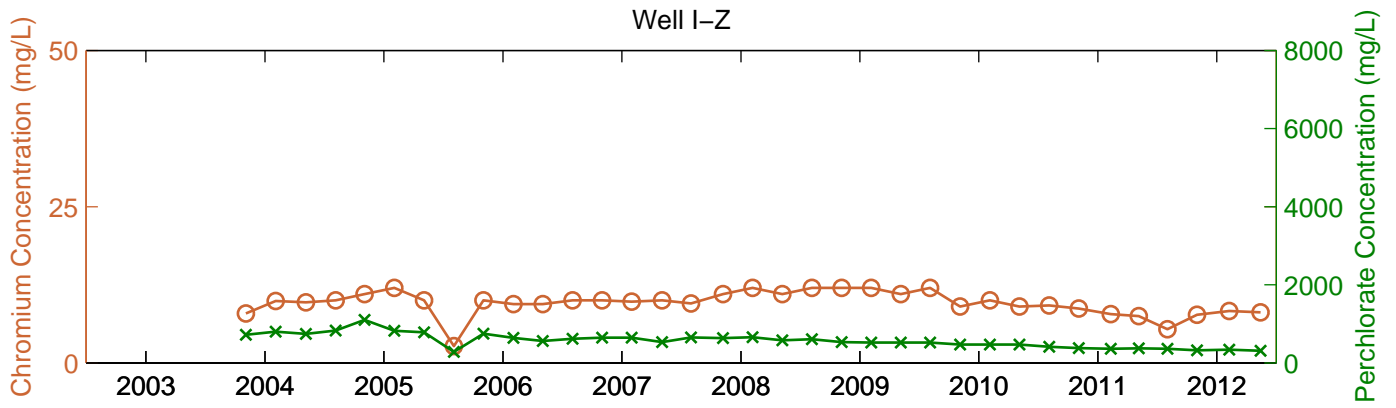

* Extraction rates for FY02/03 are the average of discharge rates reported for December 2002 and June 2003.

Attachment F-2
Historical Extraction Rates and Mass Removal Plots
for all Wells in the Athens Road Well Field

Athens Road Well Field (AWF) Summary

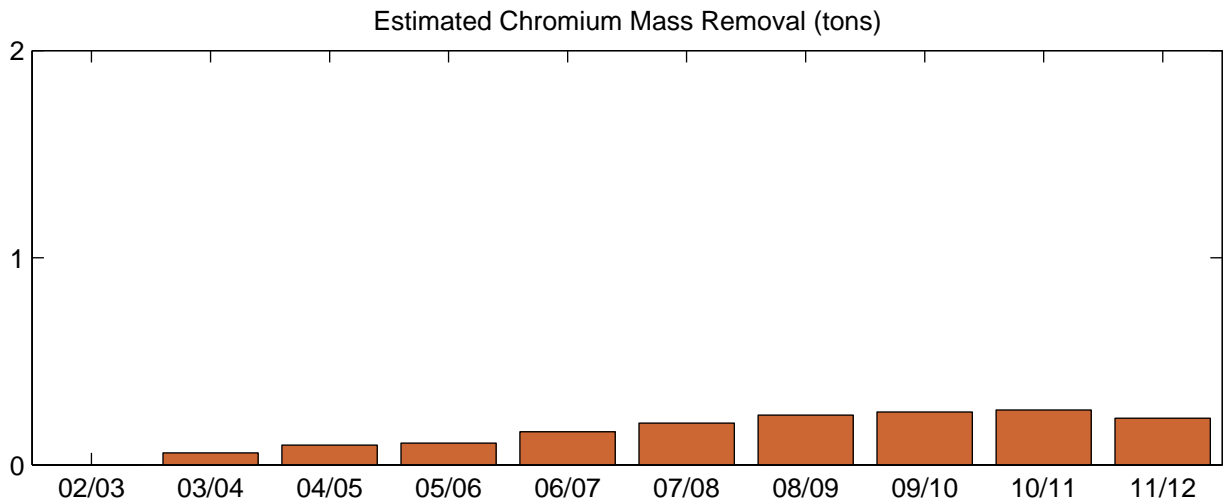
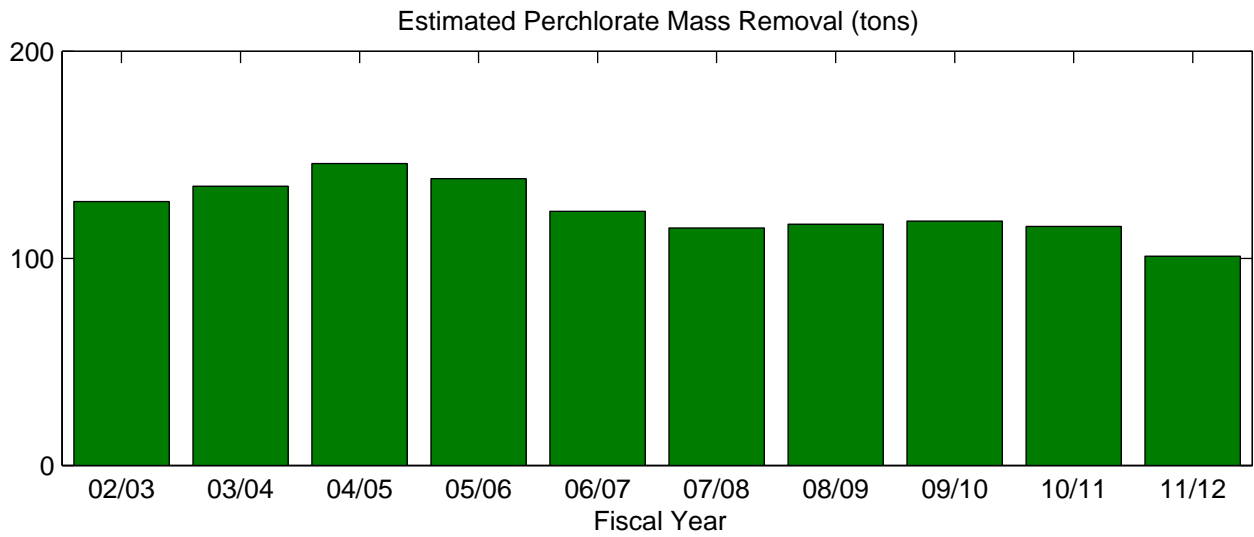
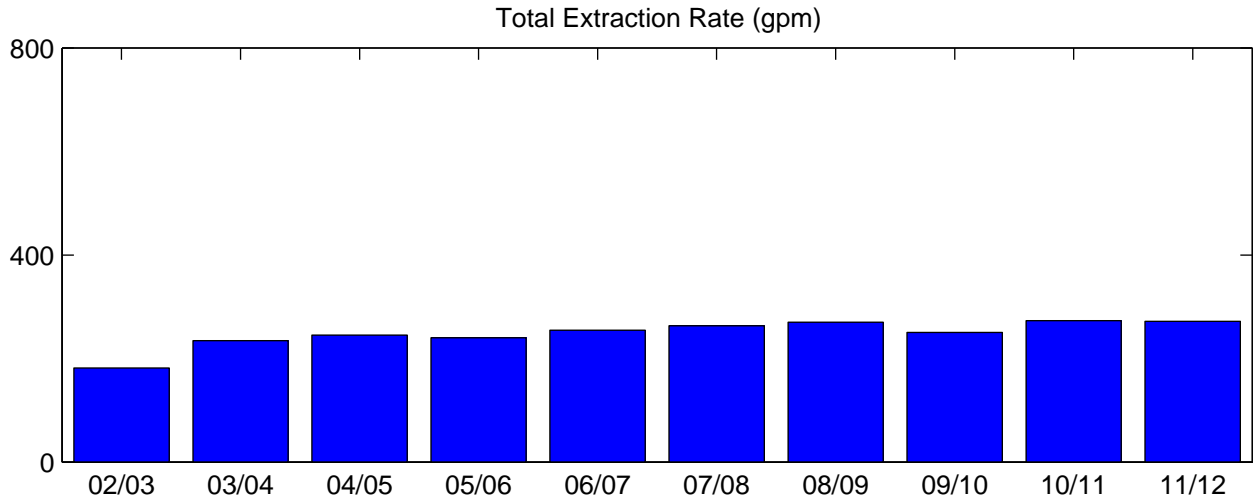

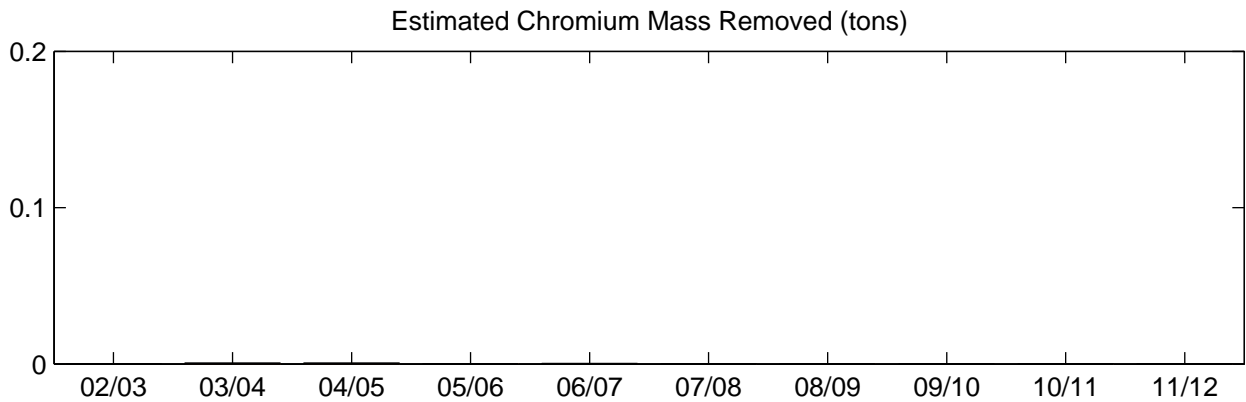
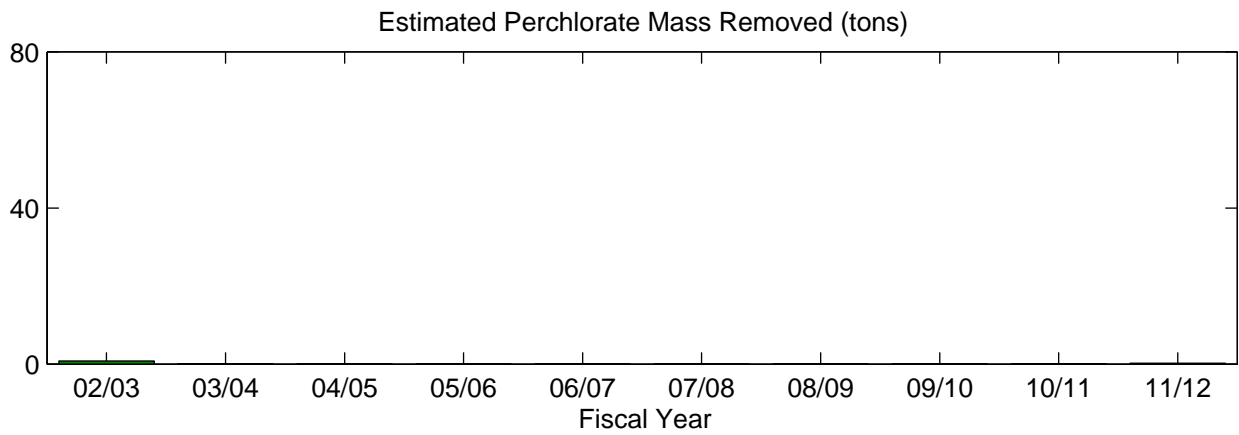
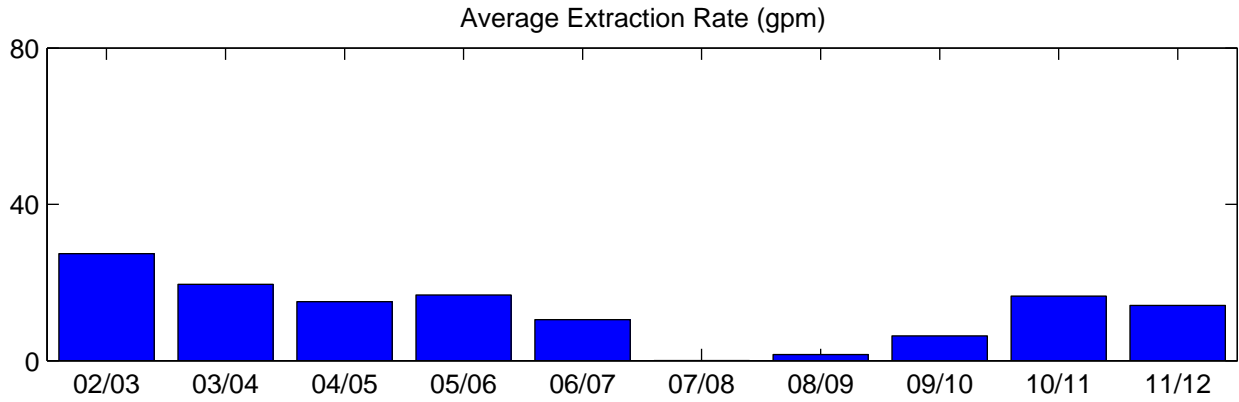
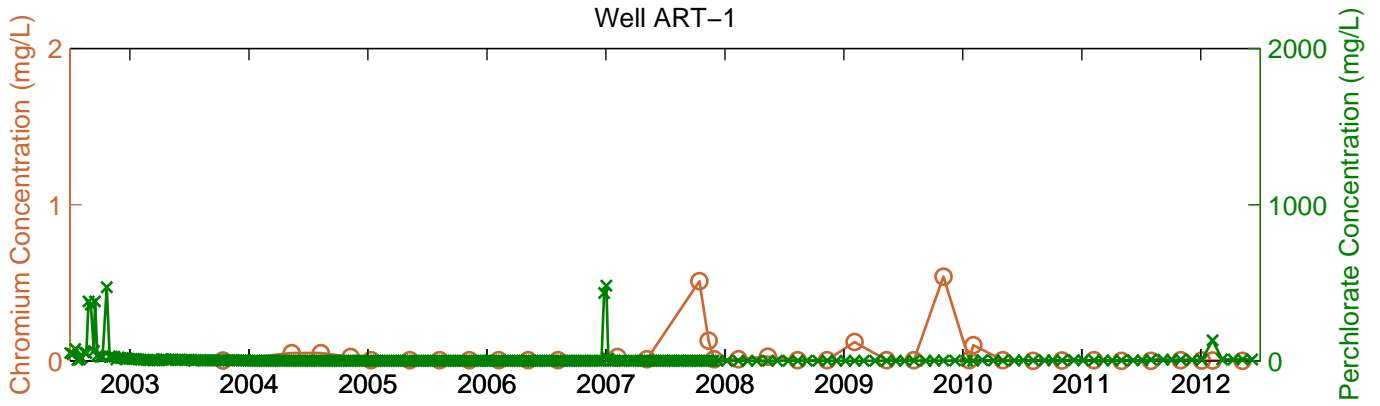

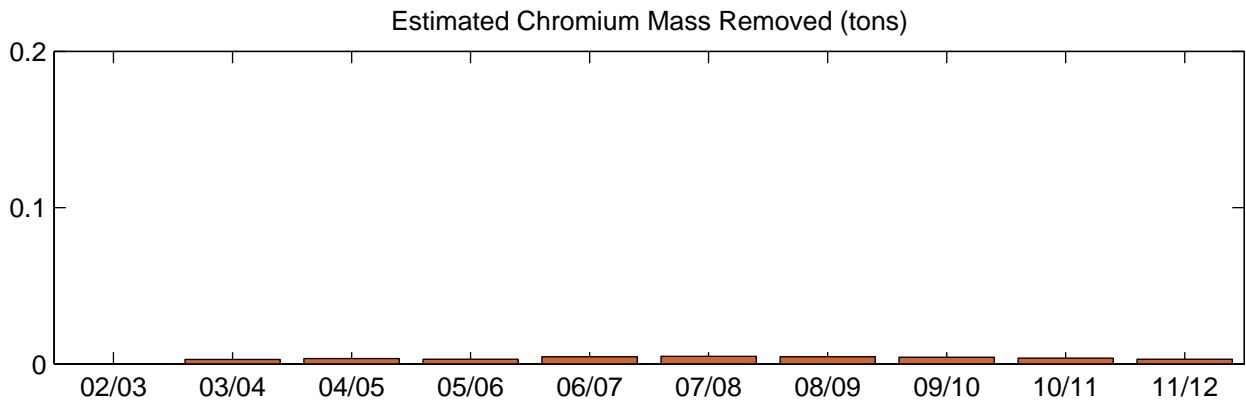
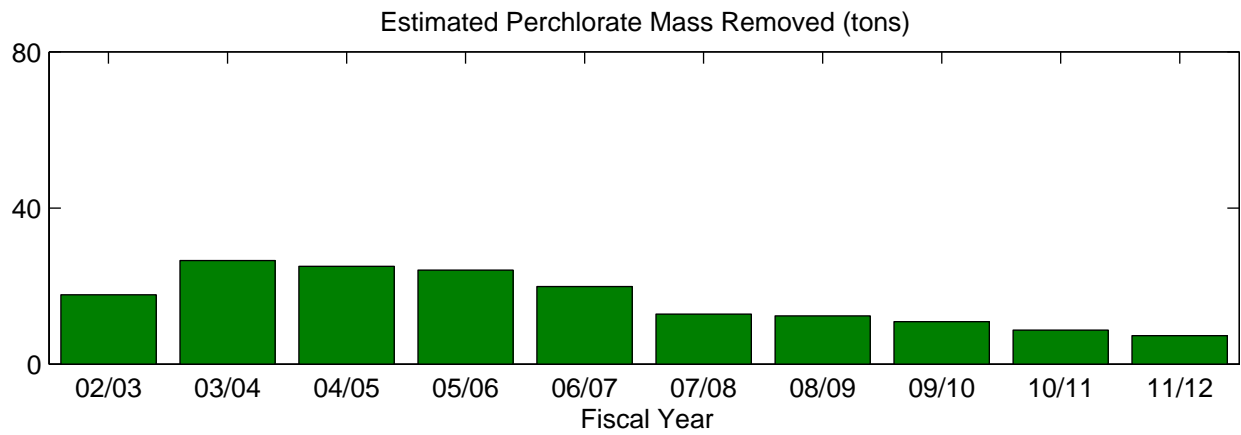
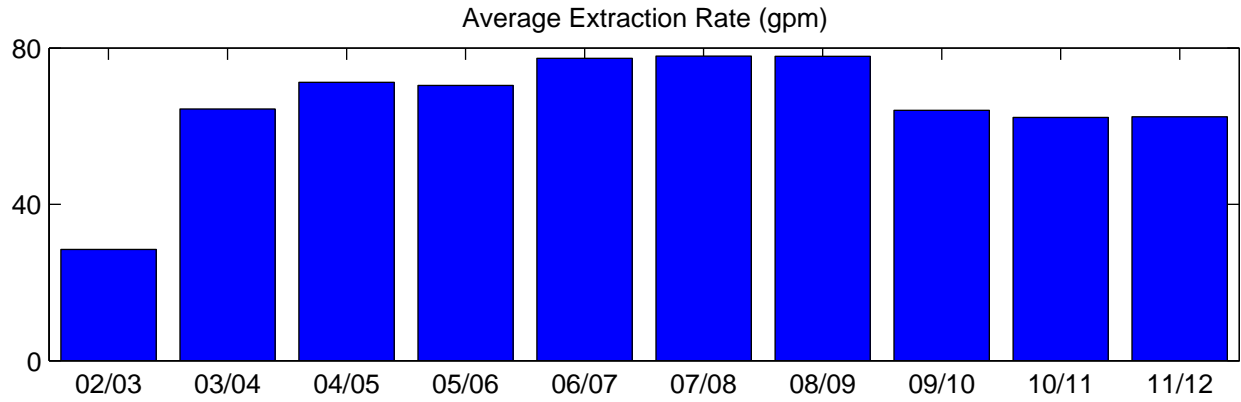
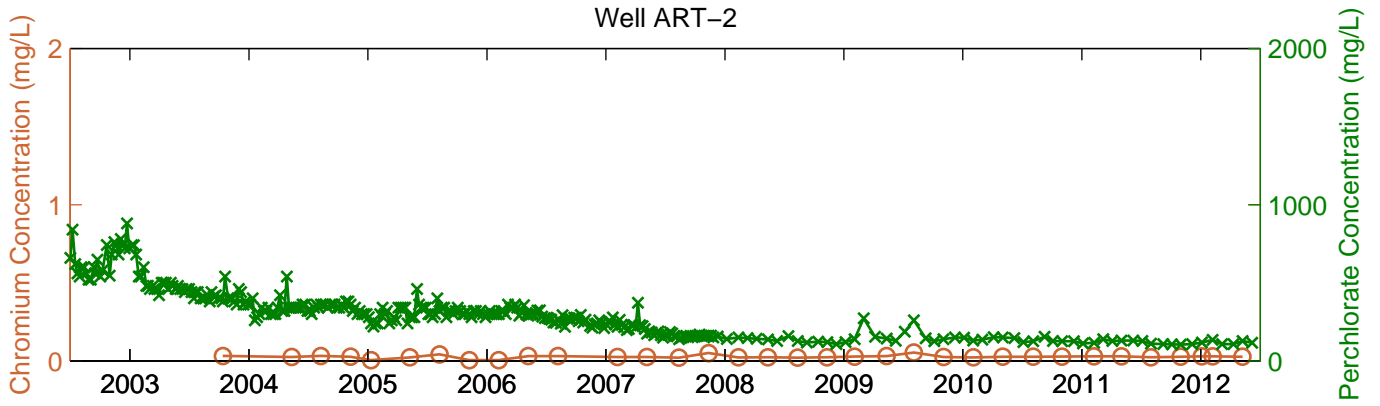

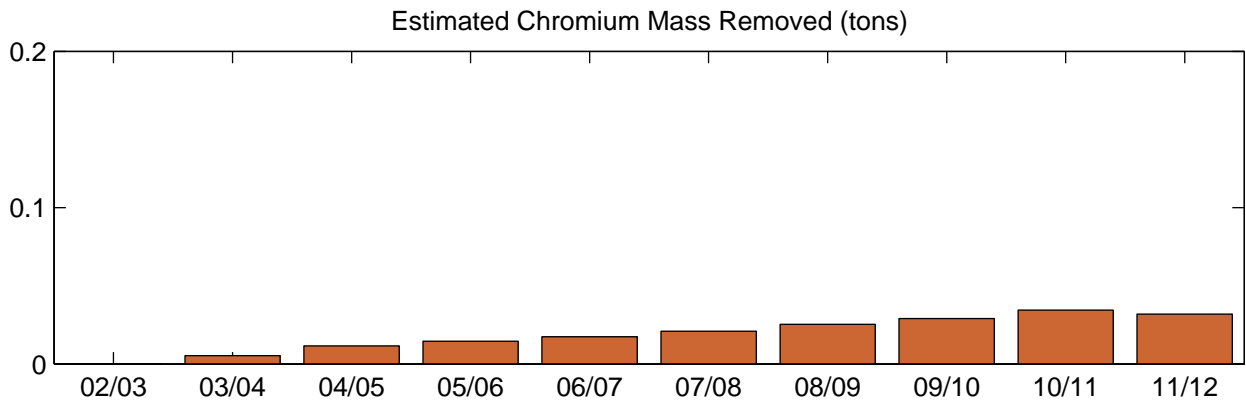
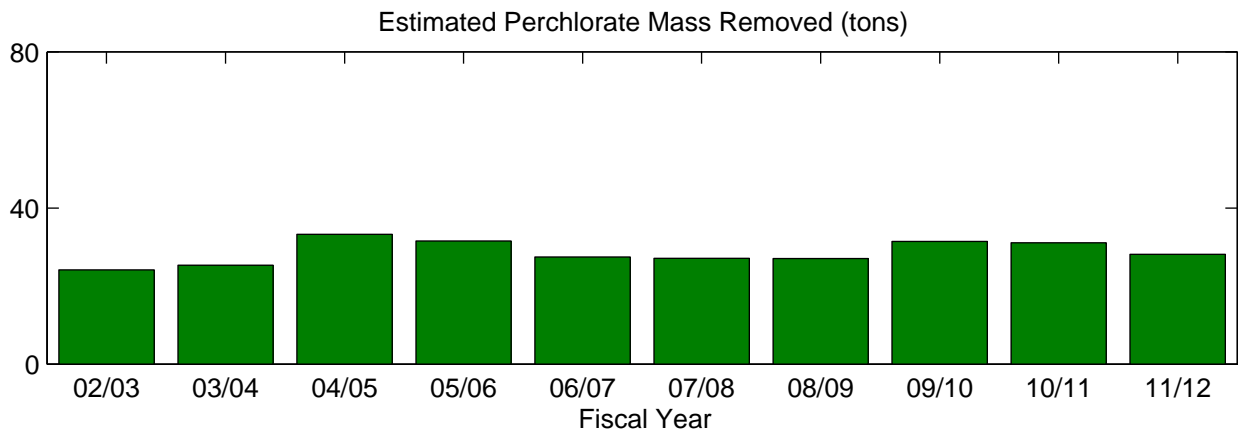
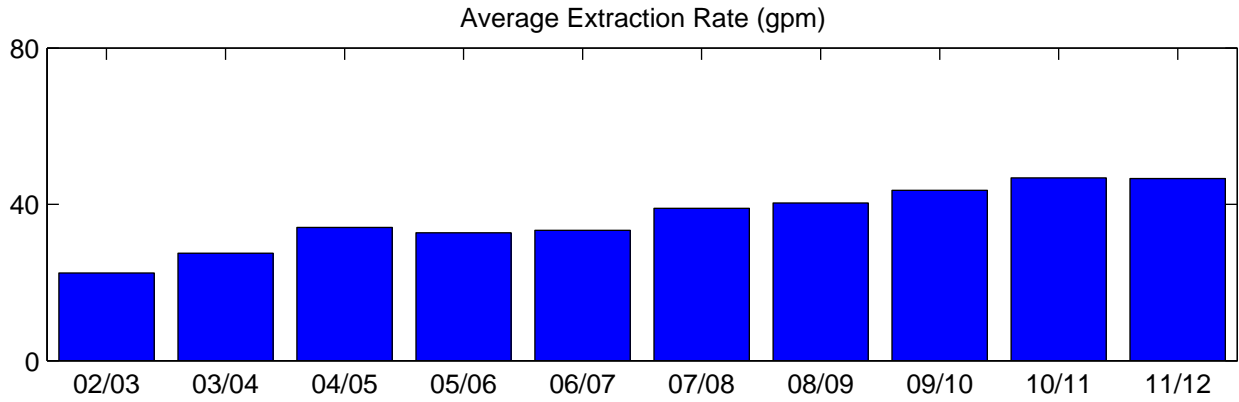
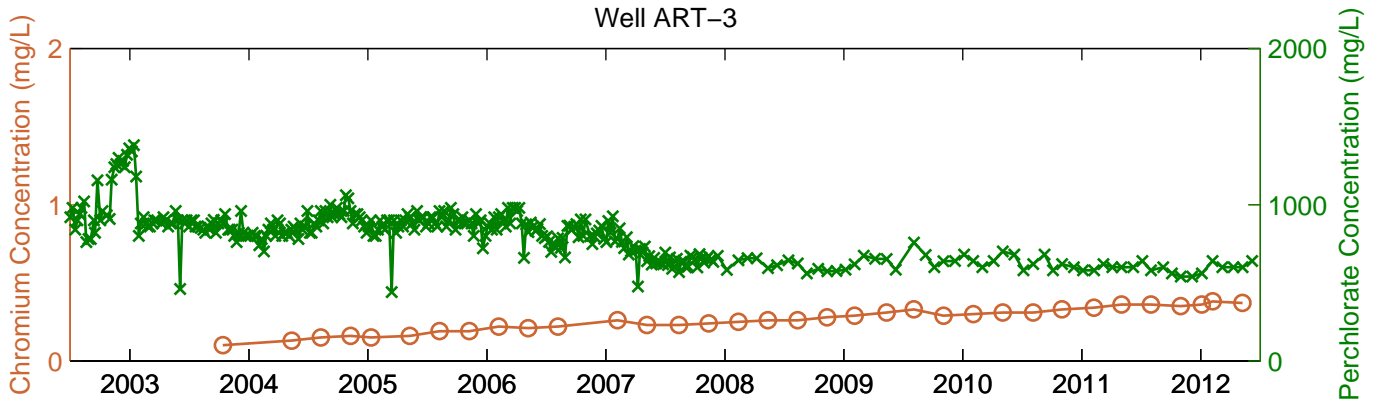

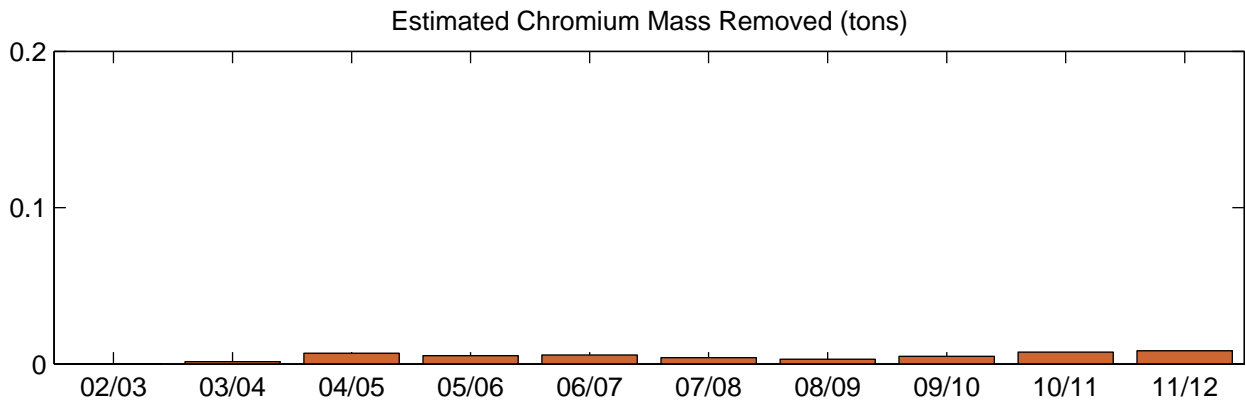
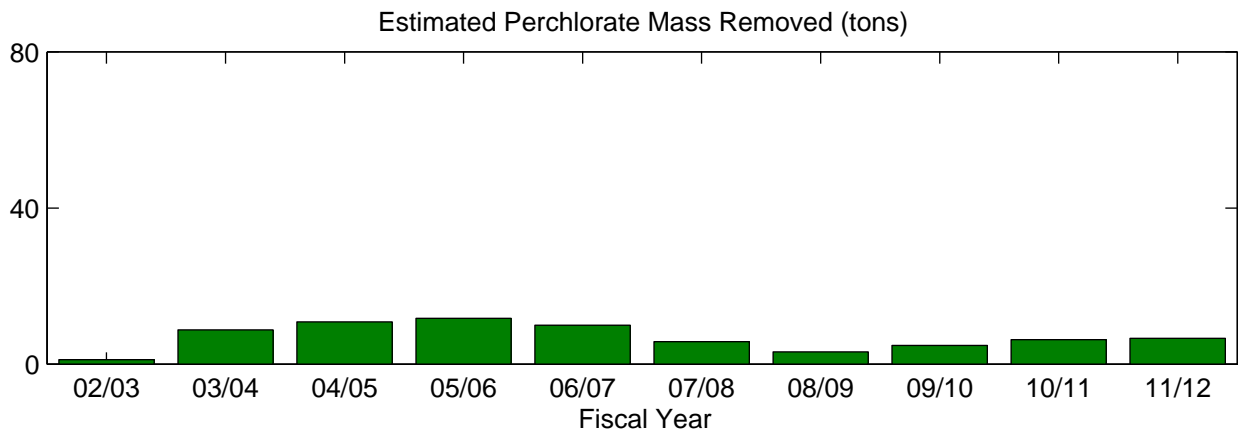
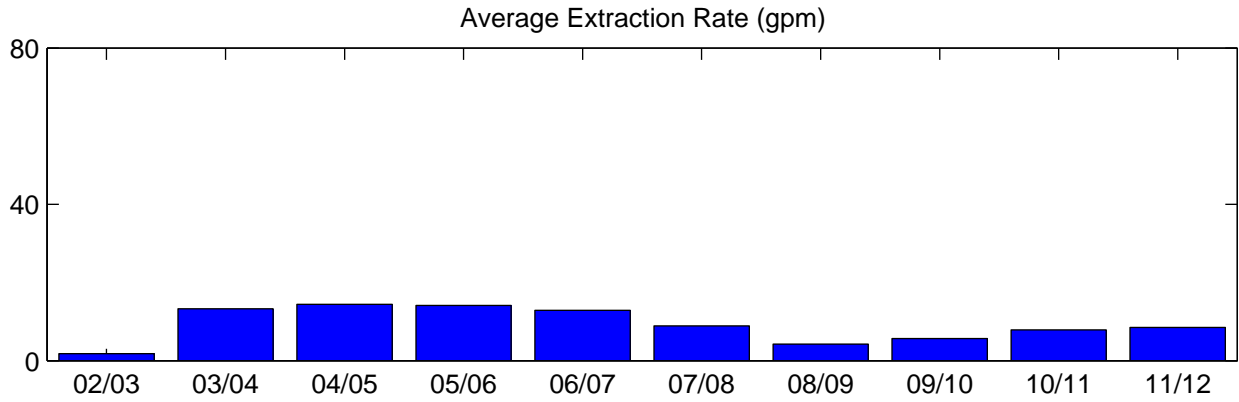
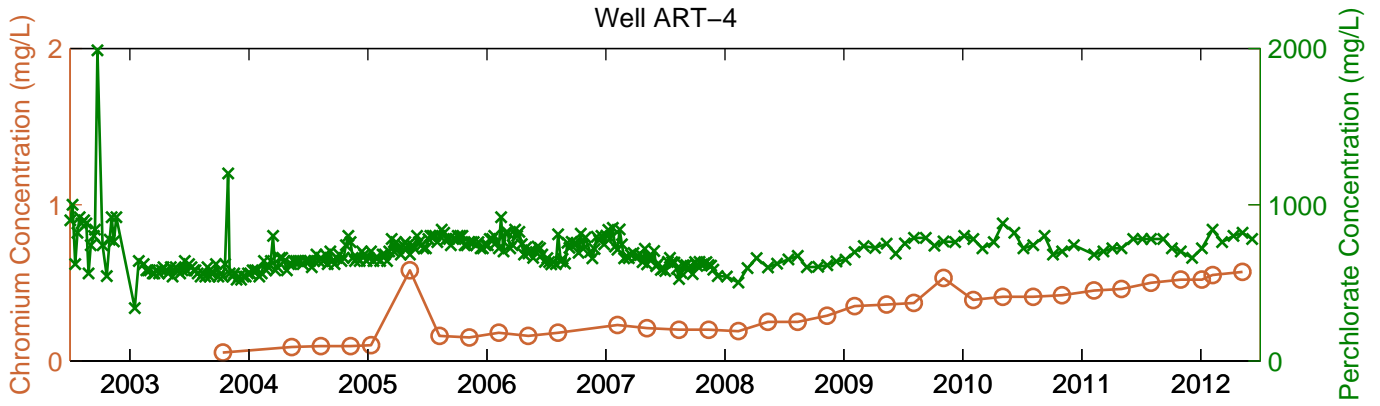

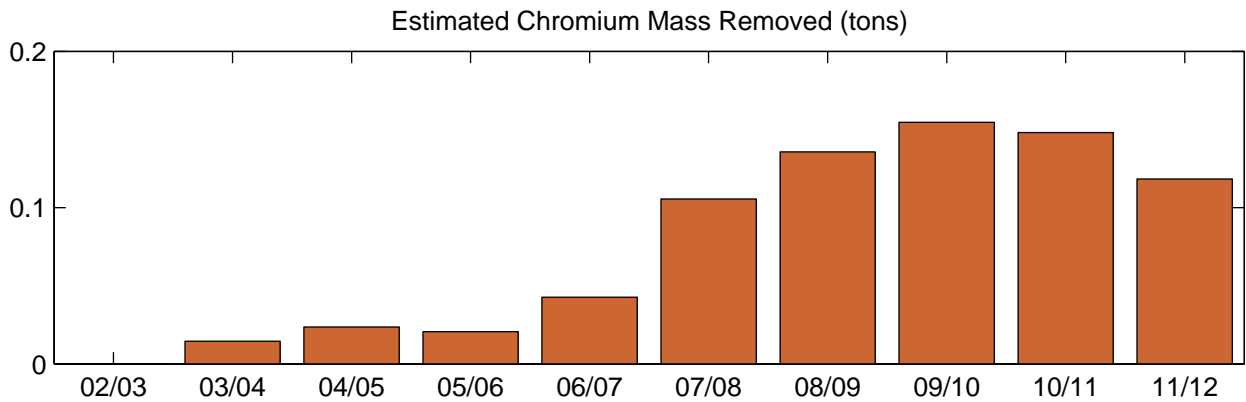
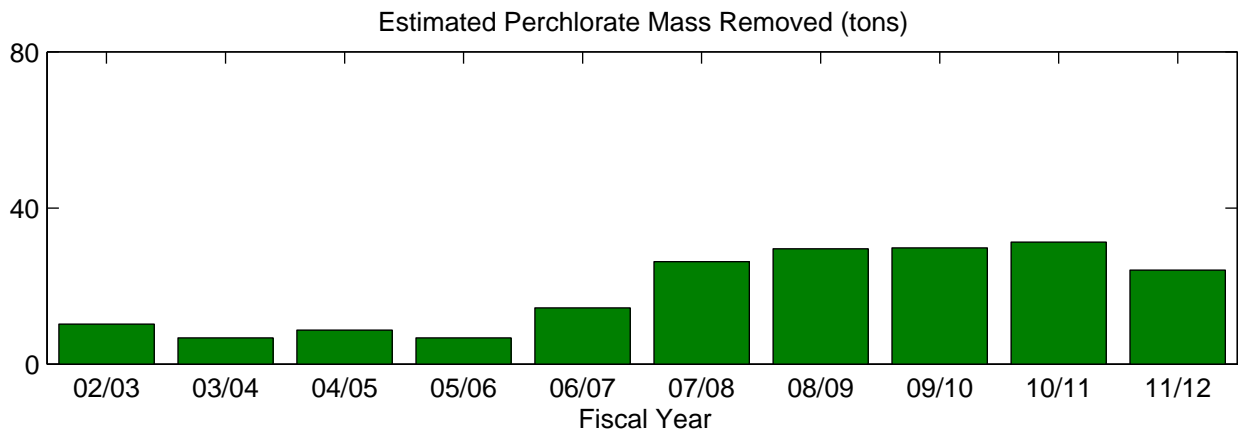
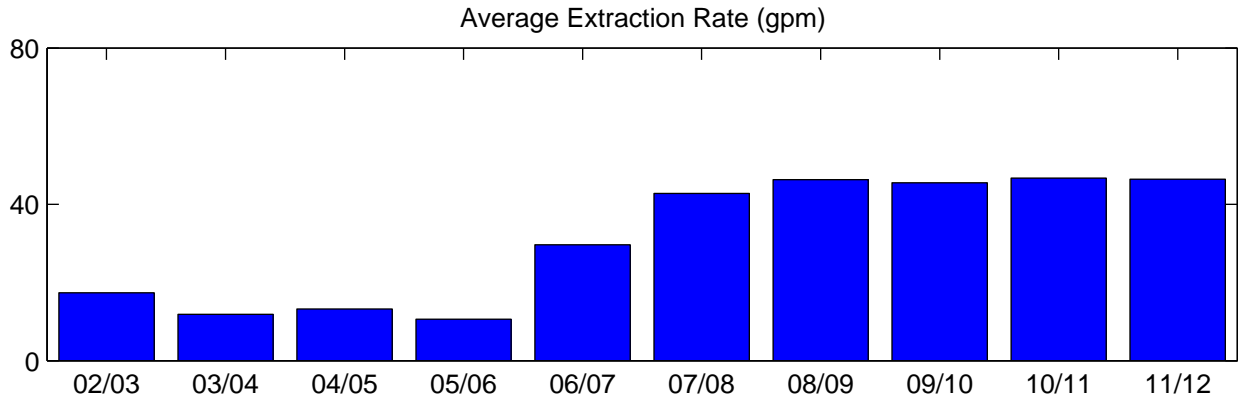
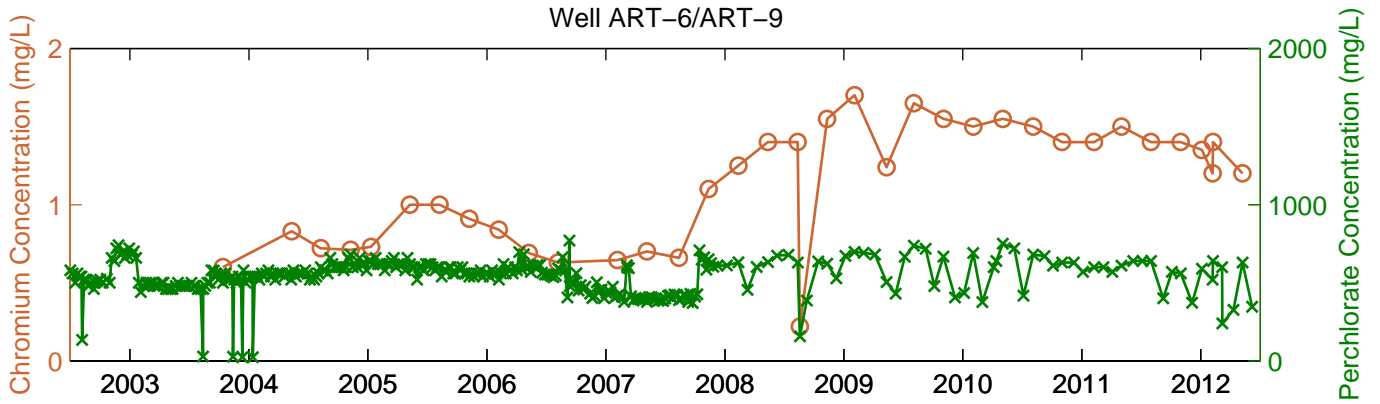

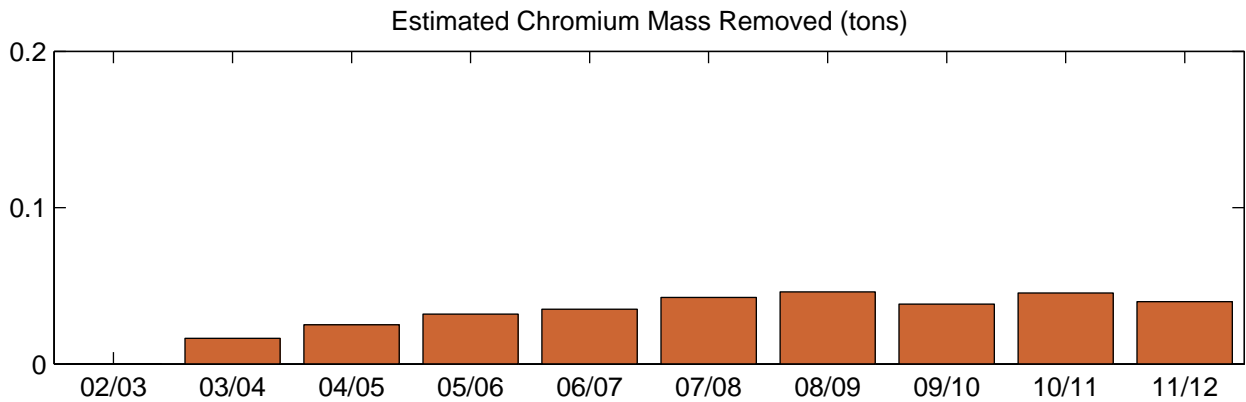
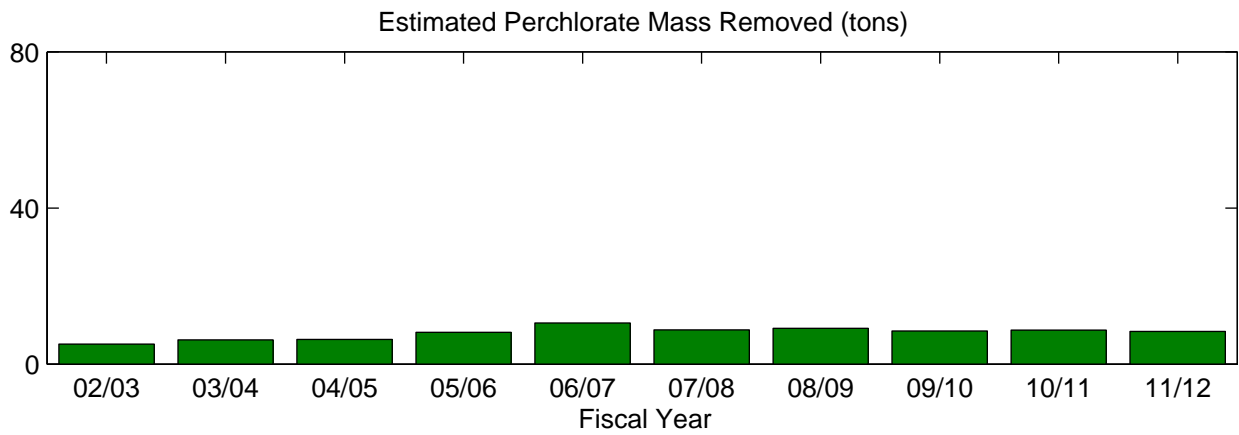
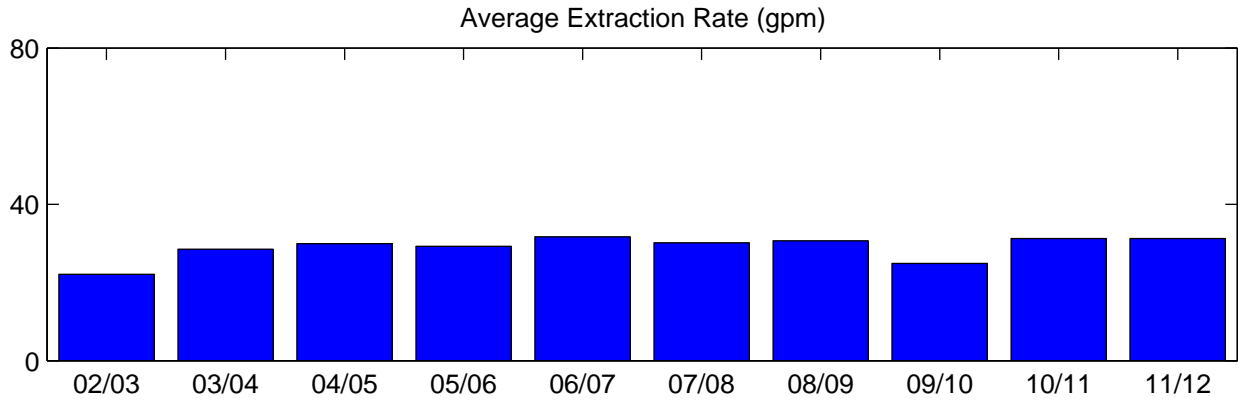
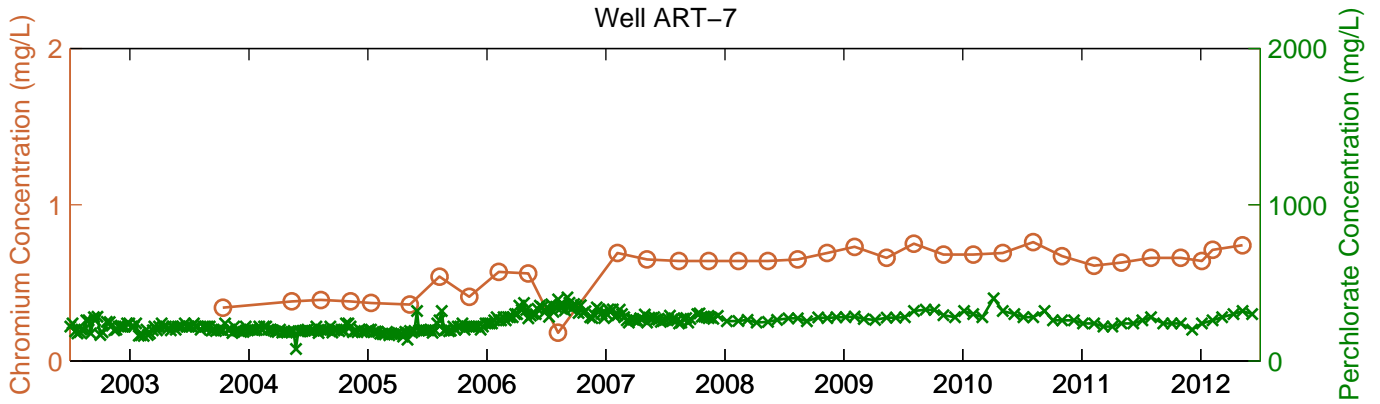

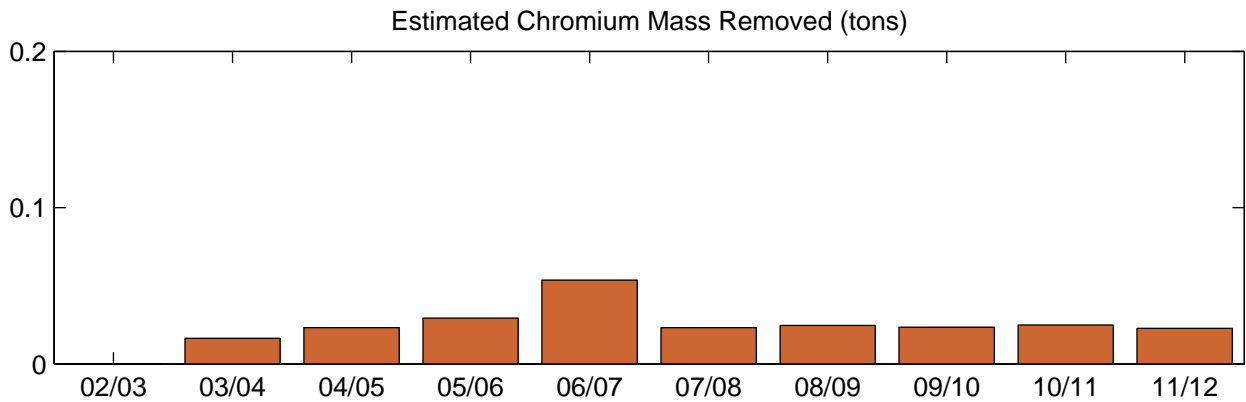
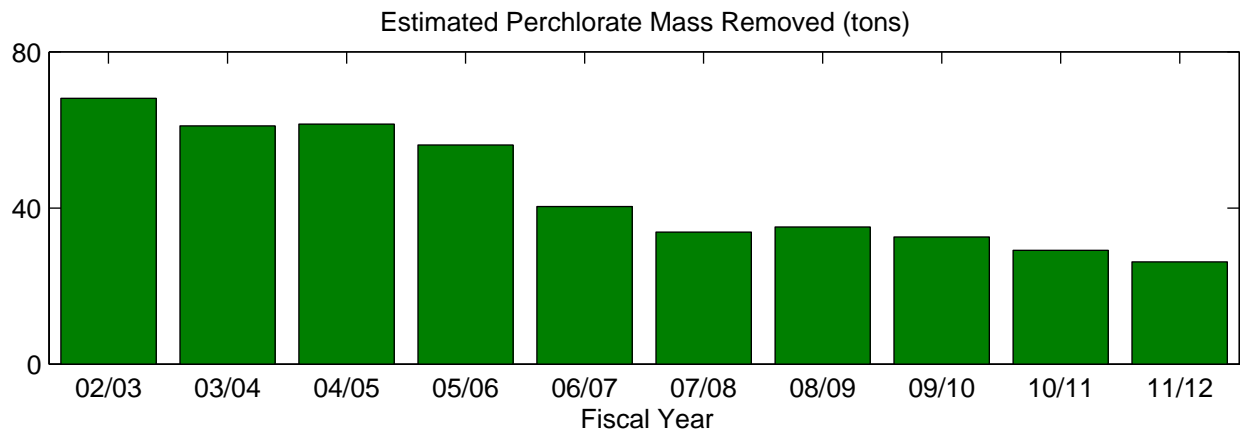
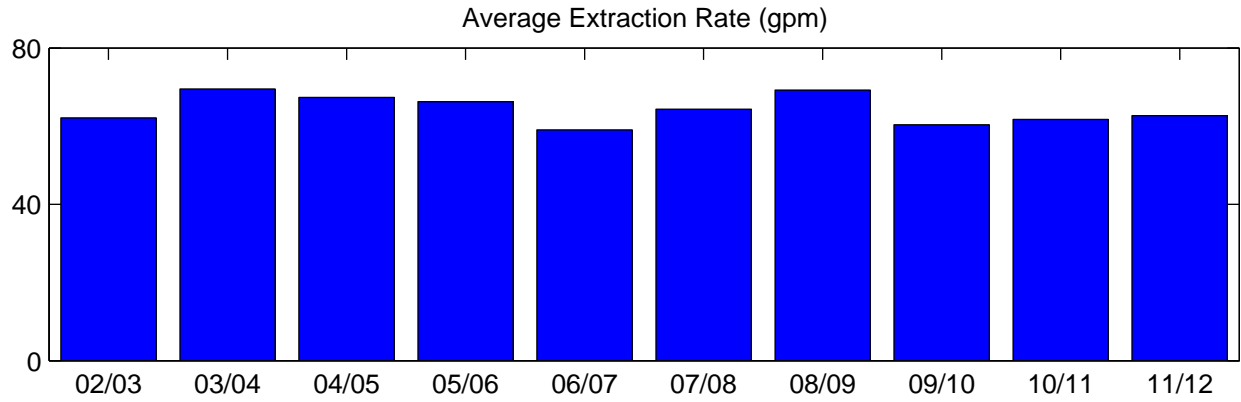
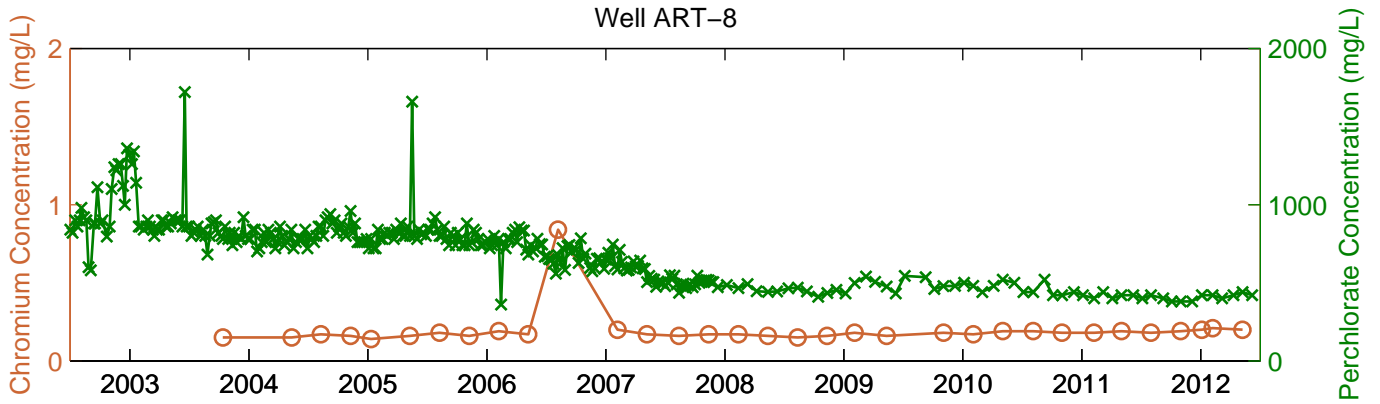

Attachment F-3
Historical Extraction Rates and Mass Removal Plots
for all Wells in the Seep Well Field

Seep Well Field (SWF) Summary

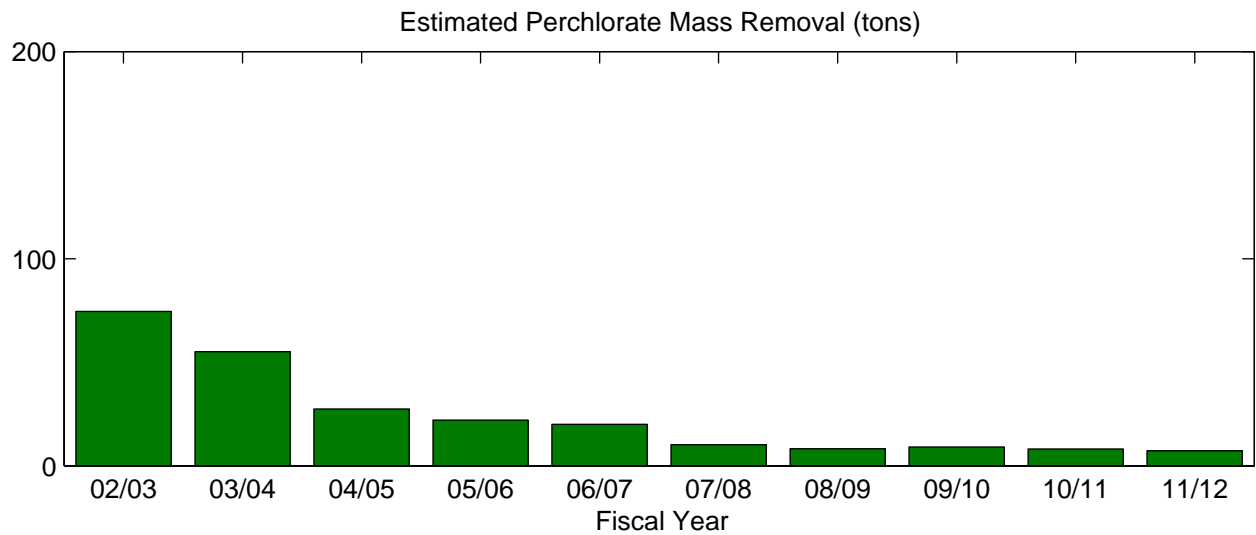
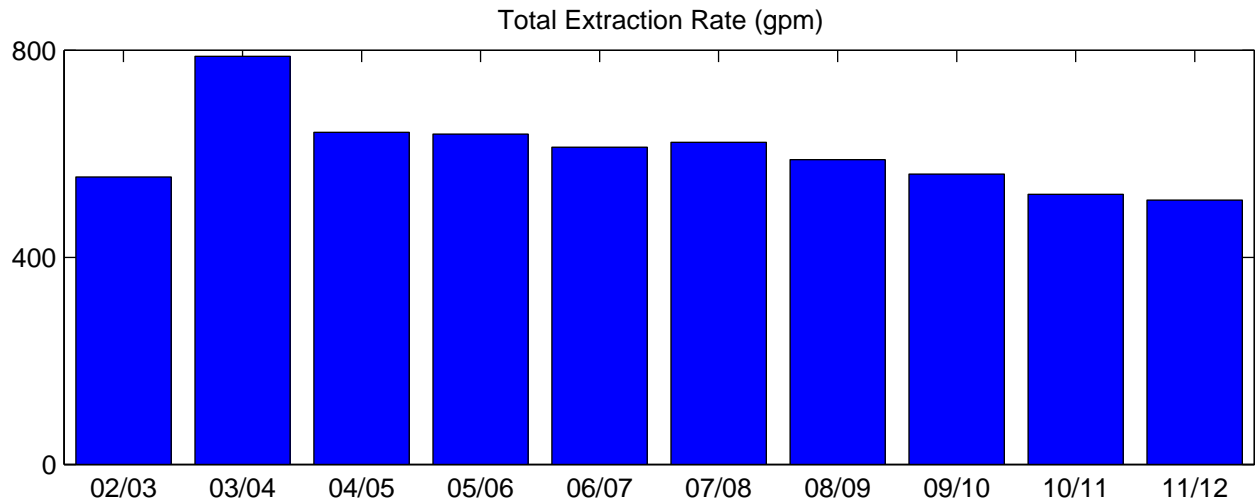

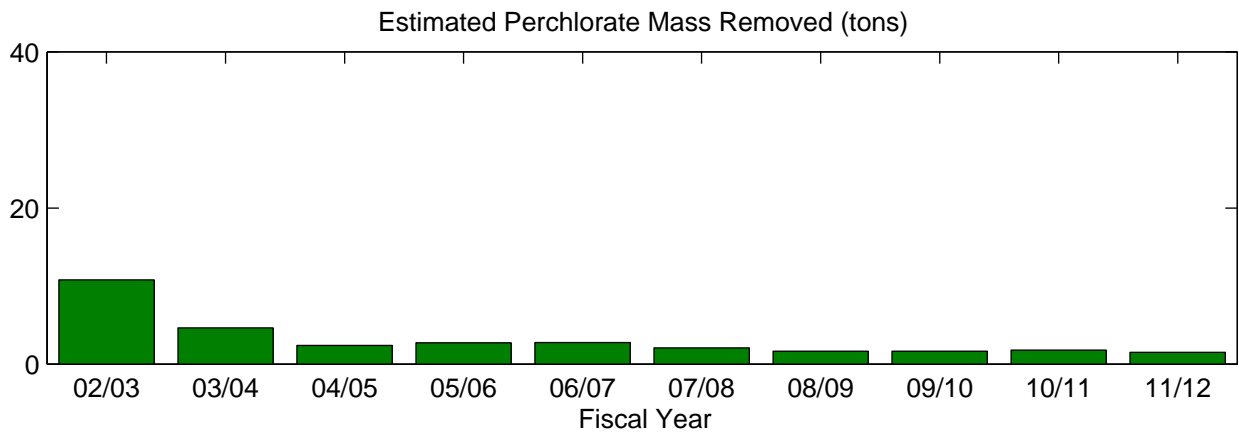
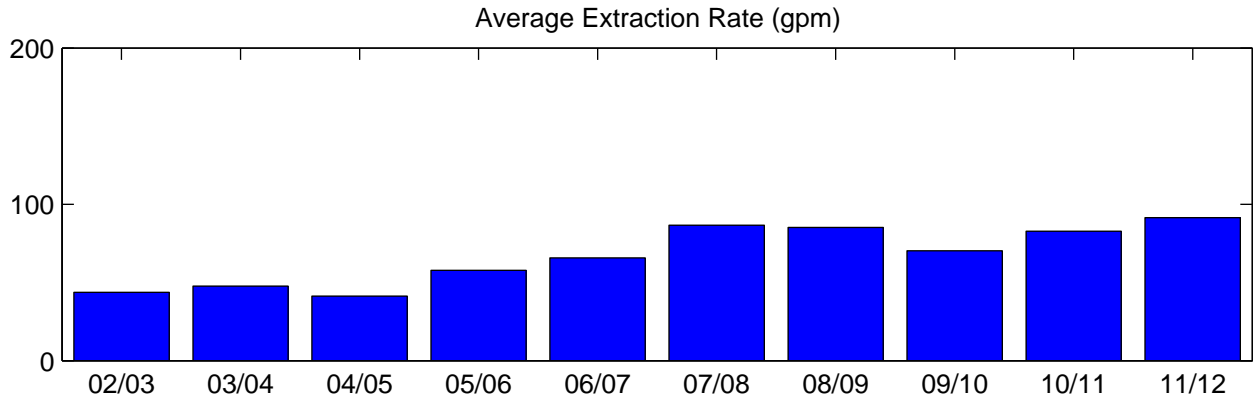
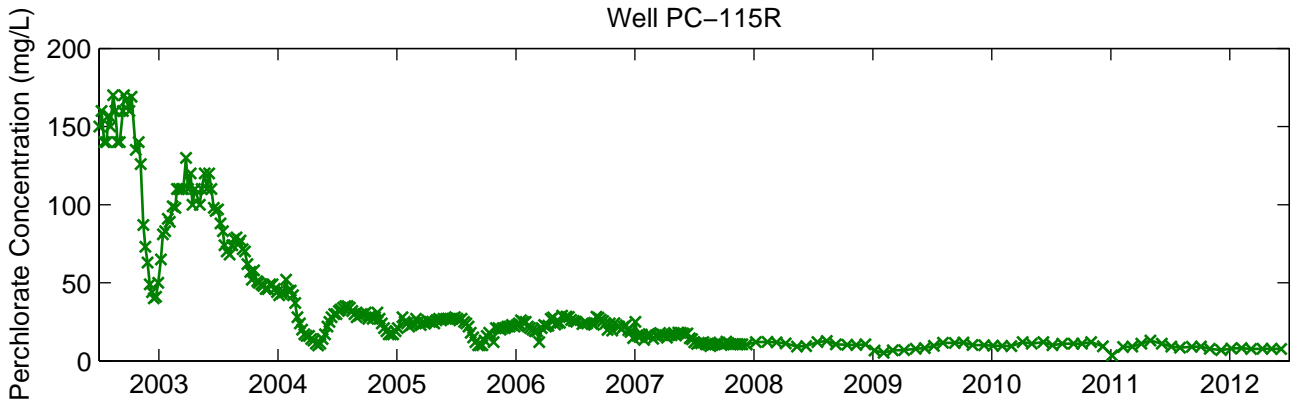

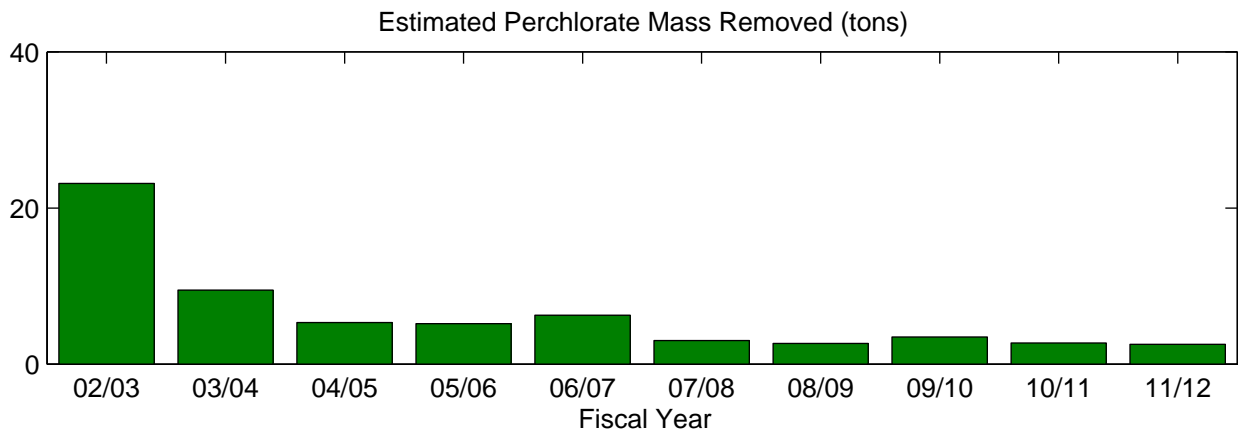
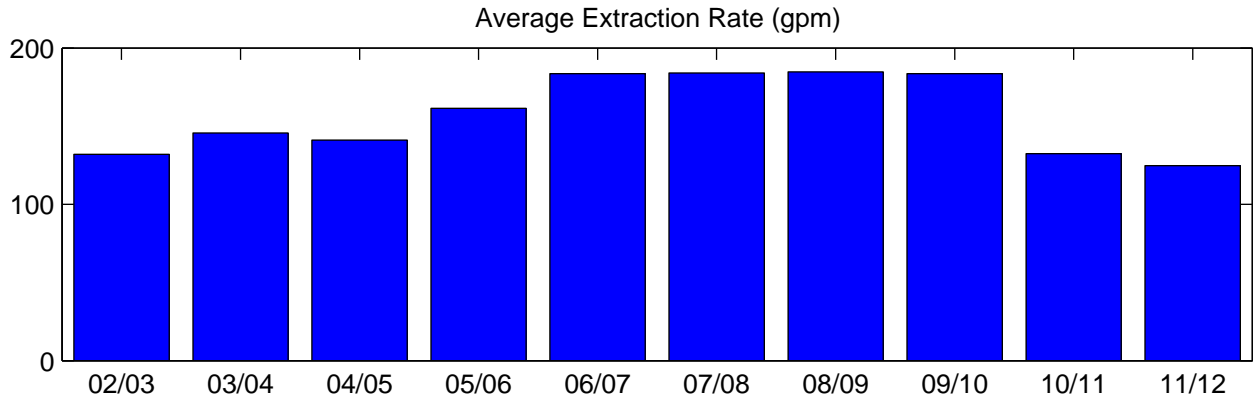
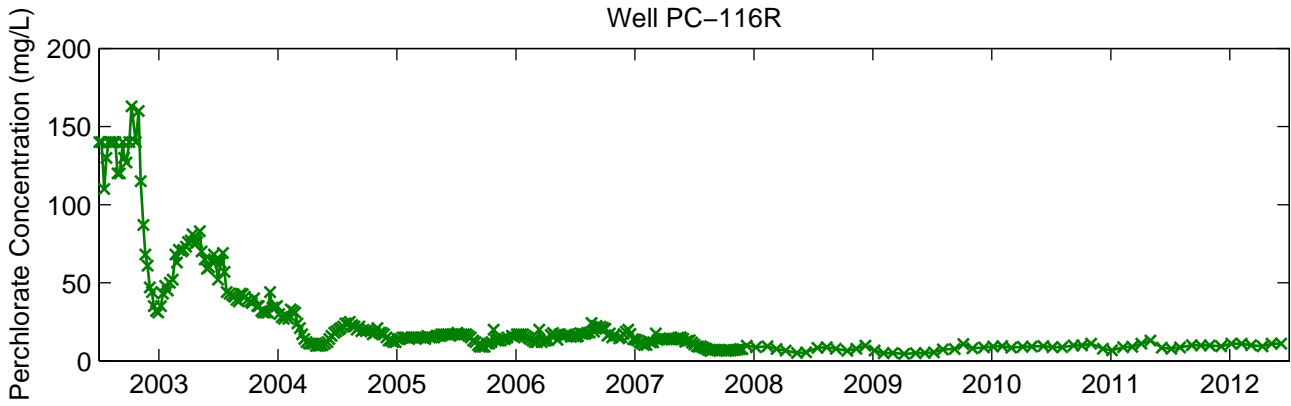

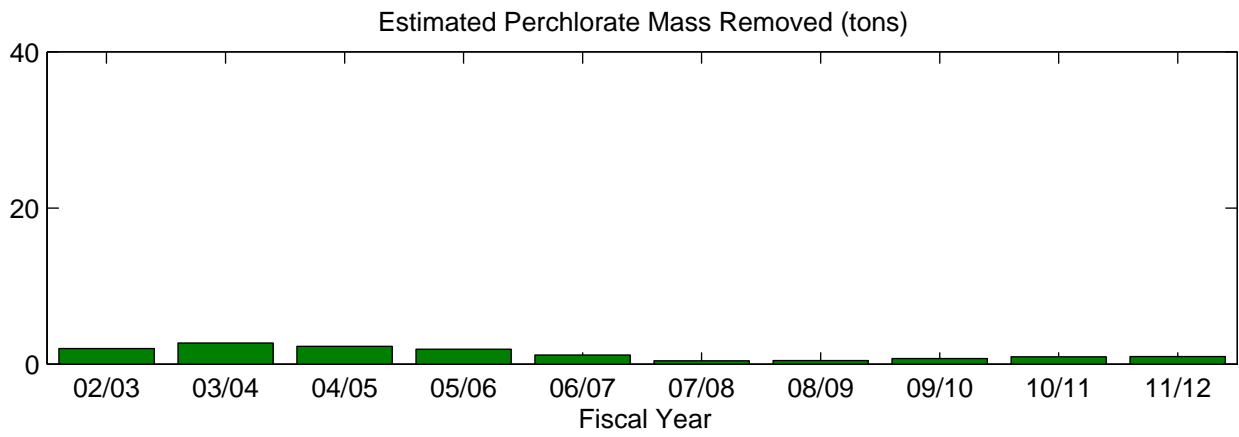
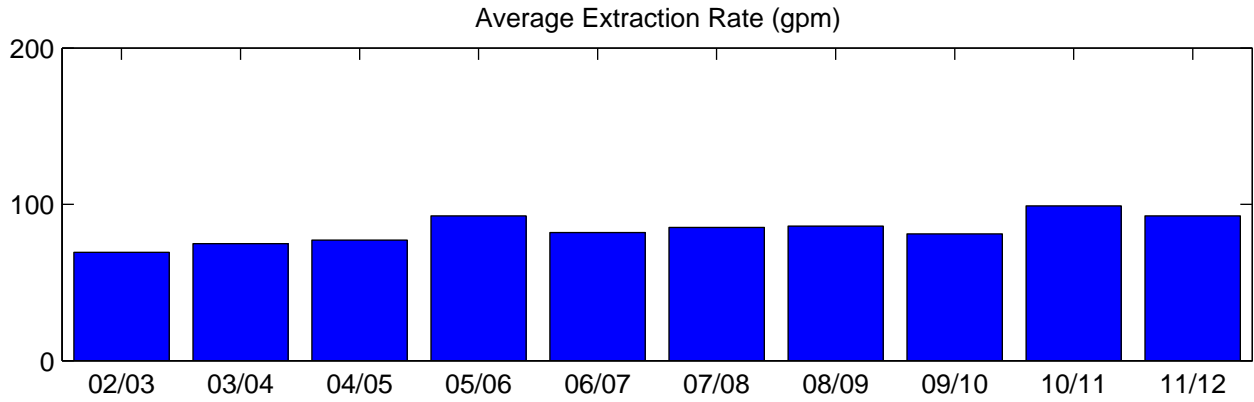
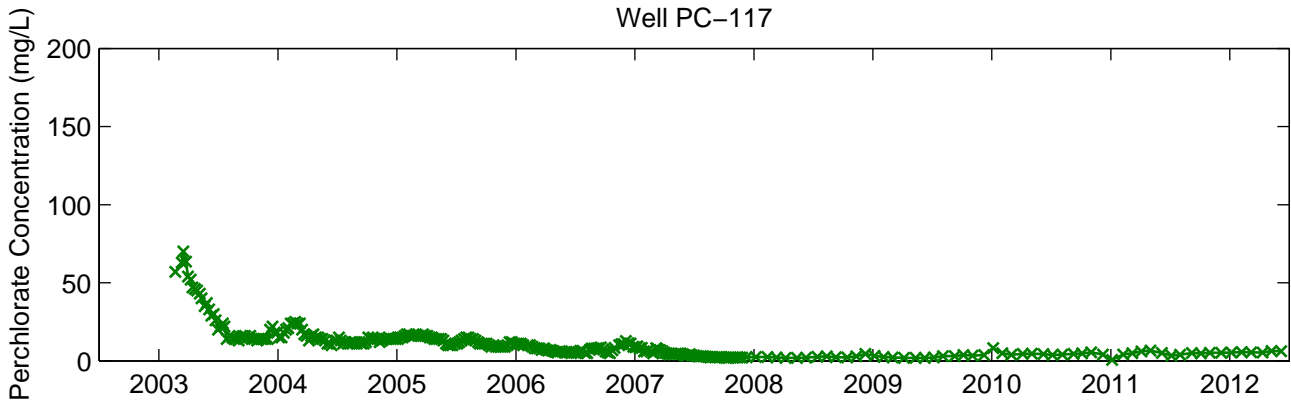

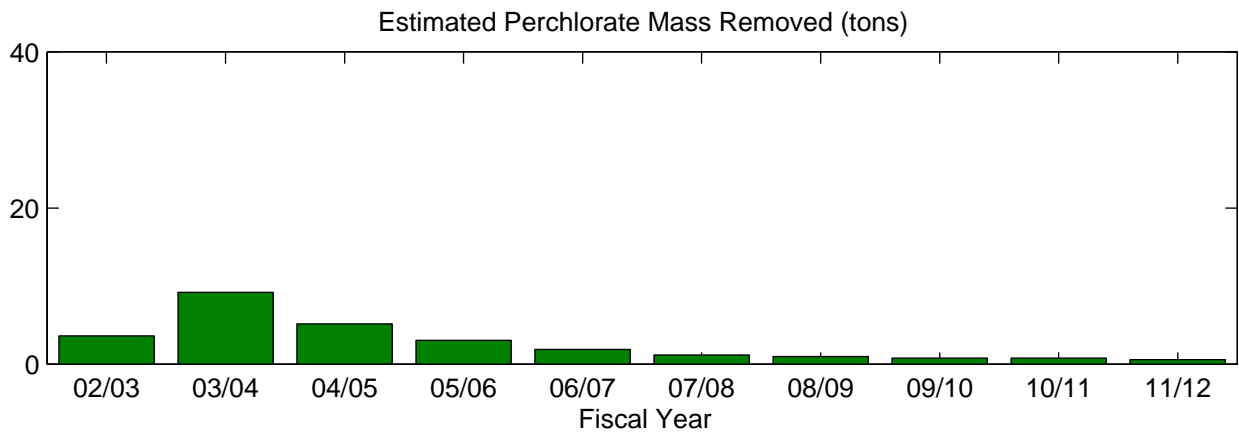
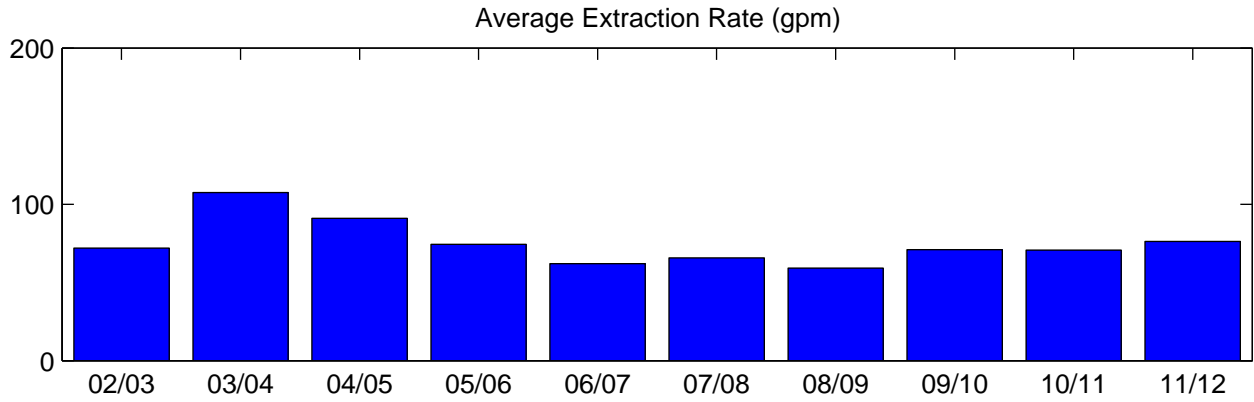
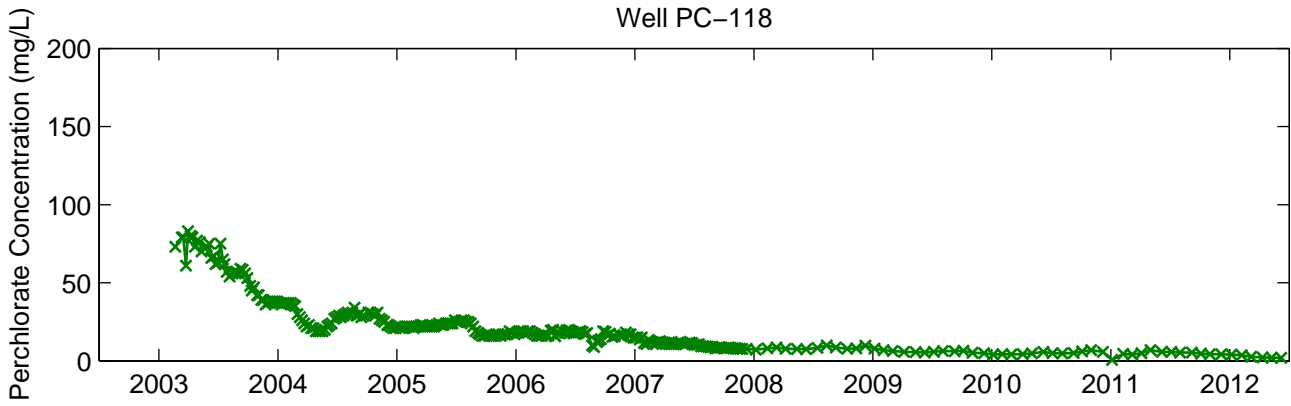

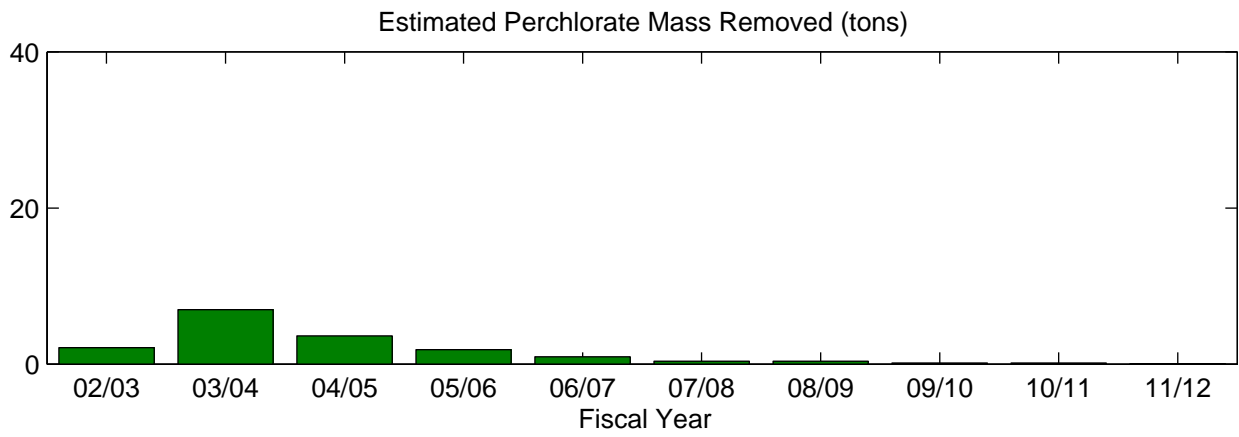
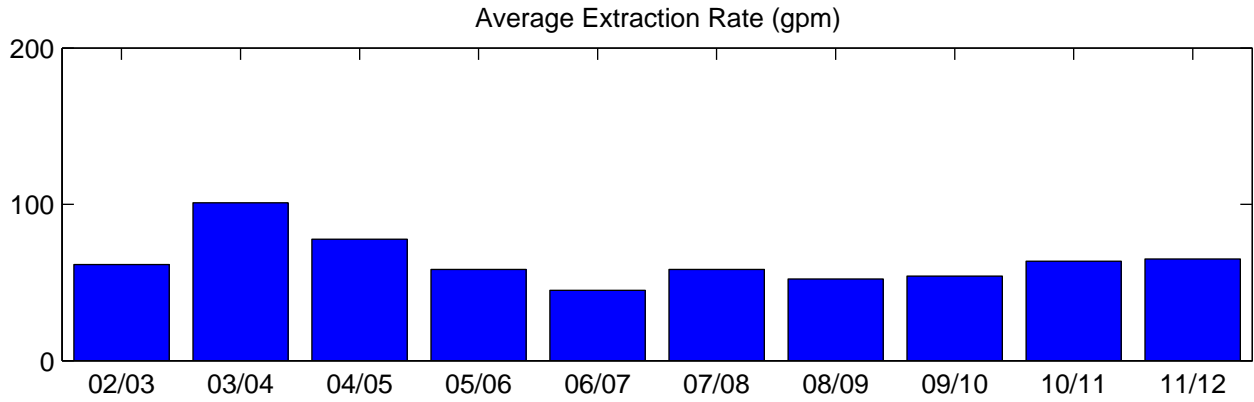
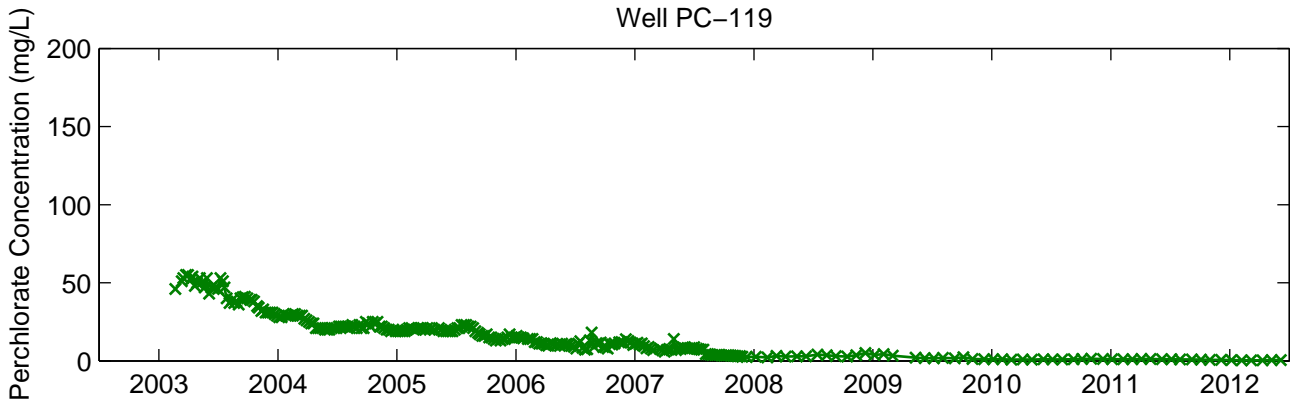

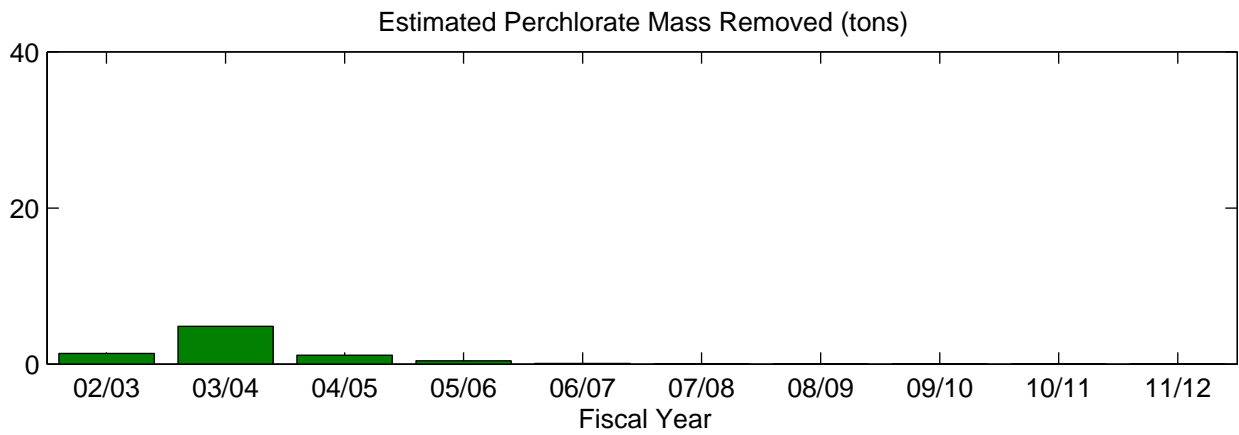
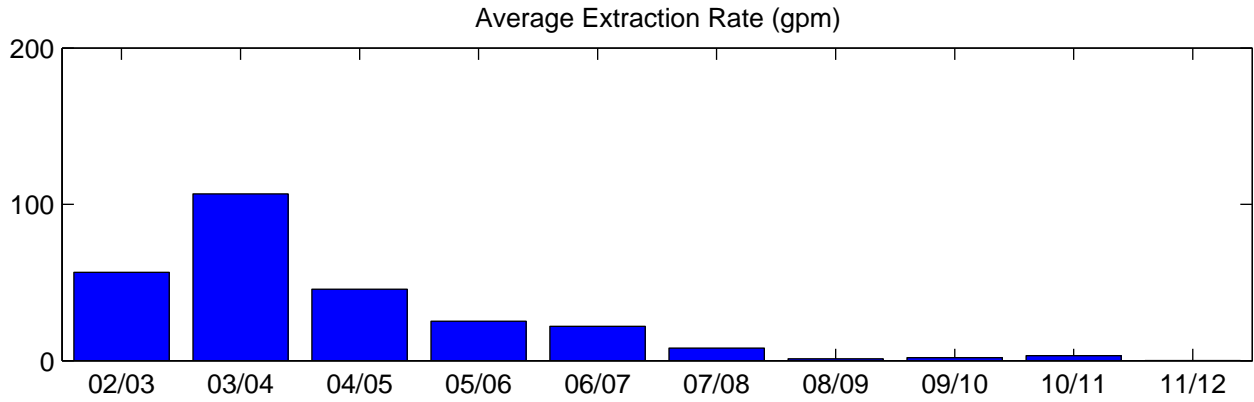
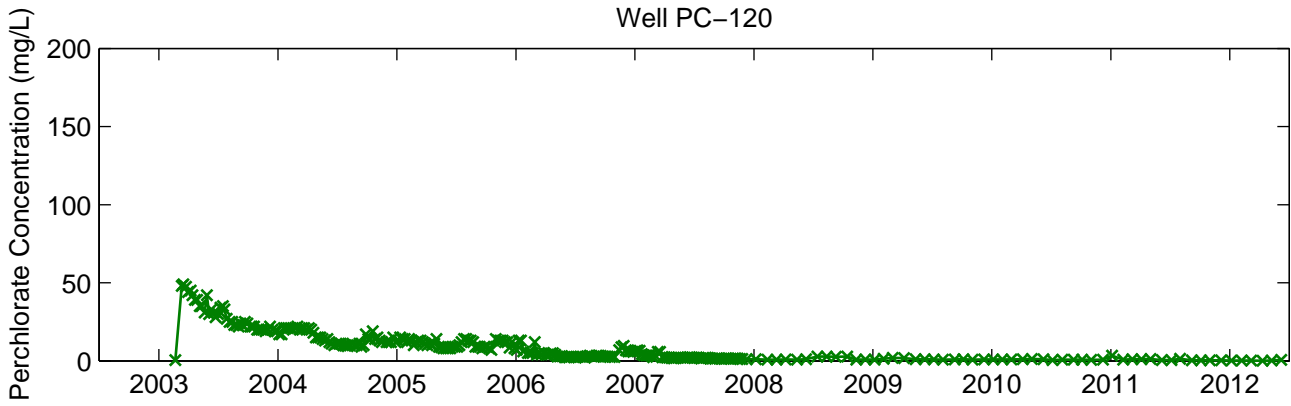

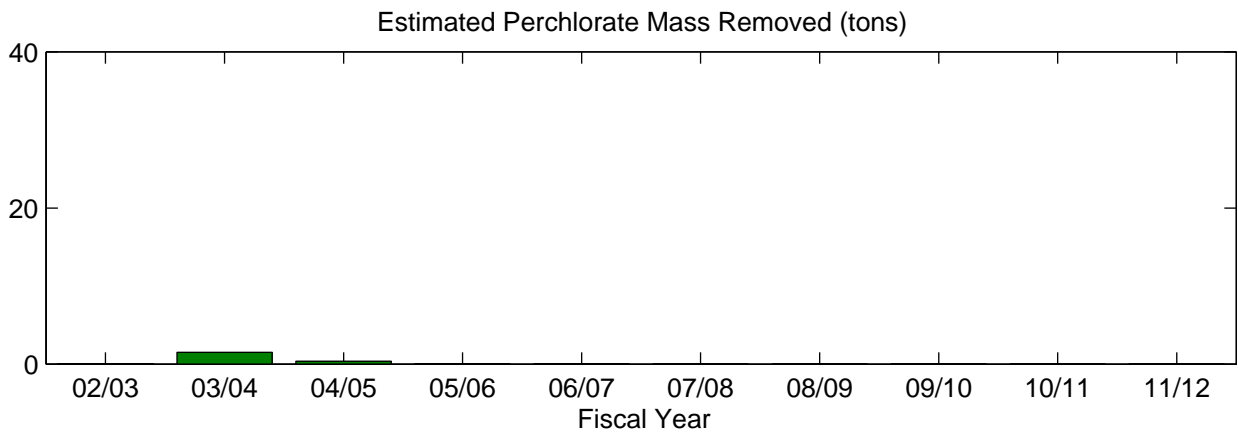
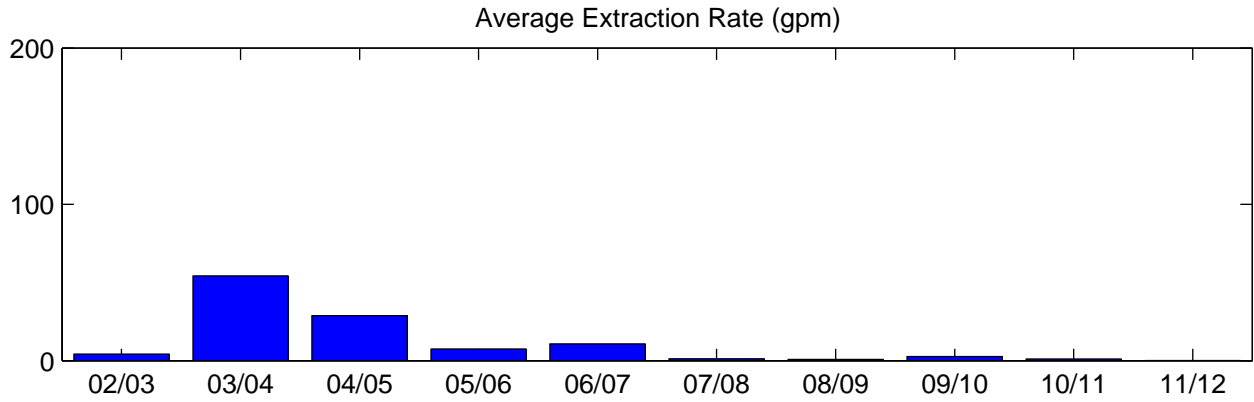
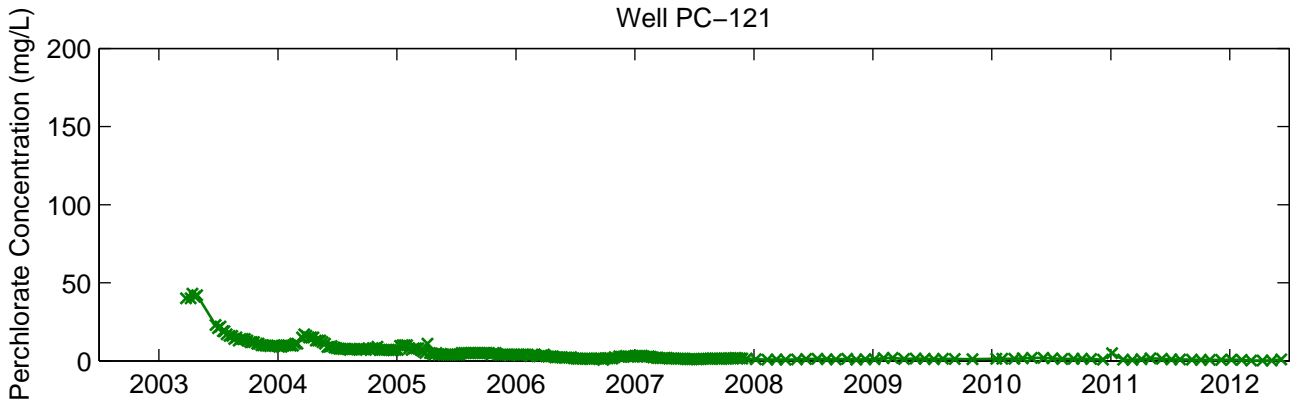

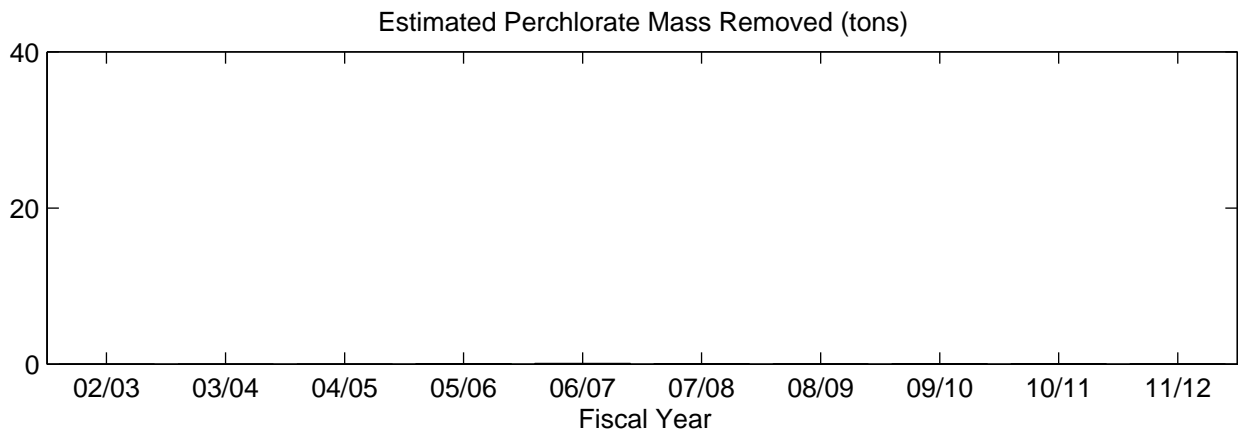
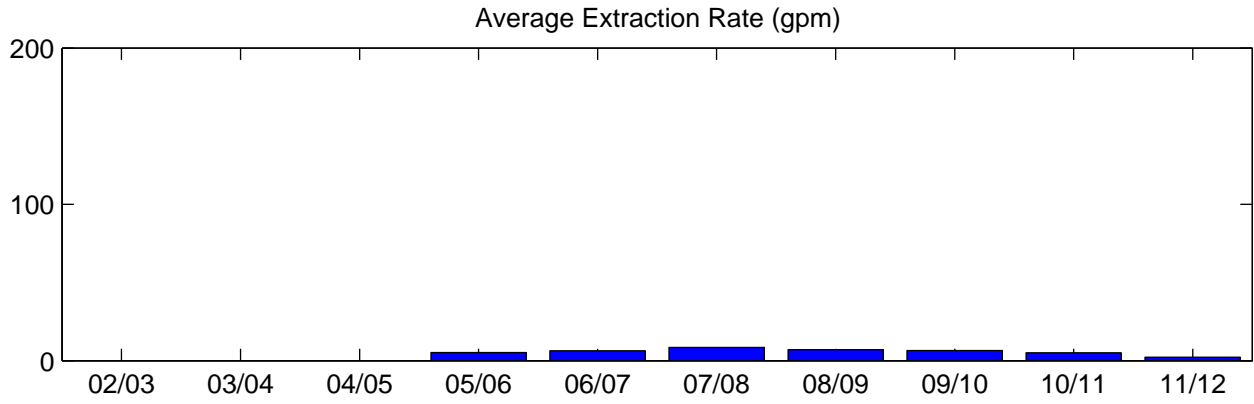
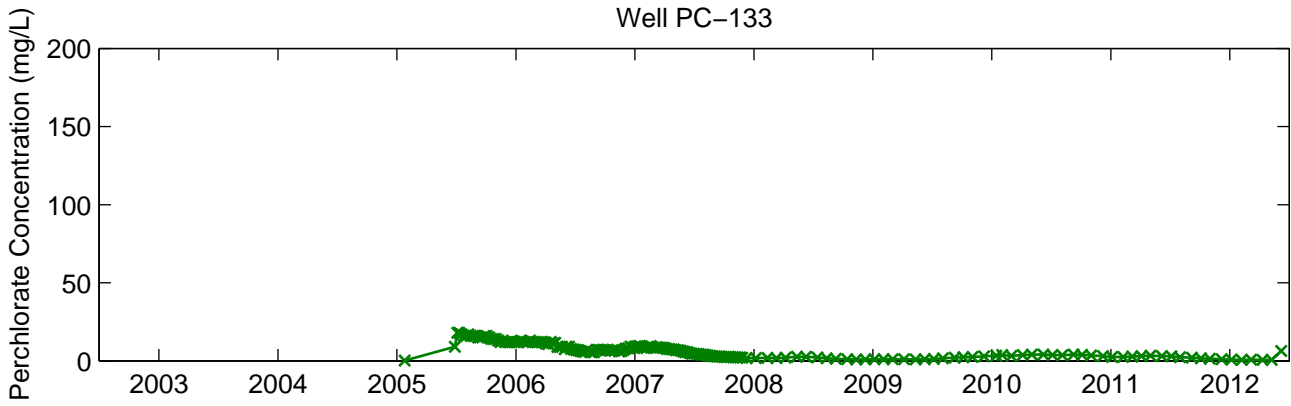

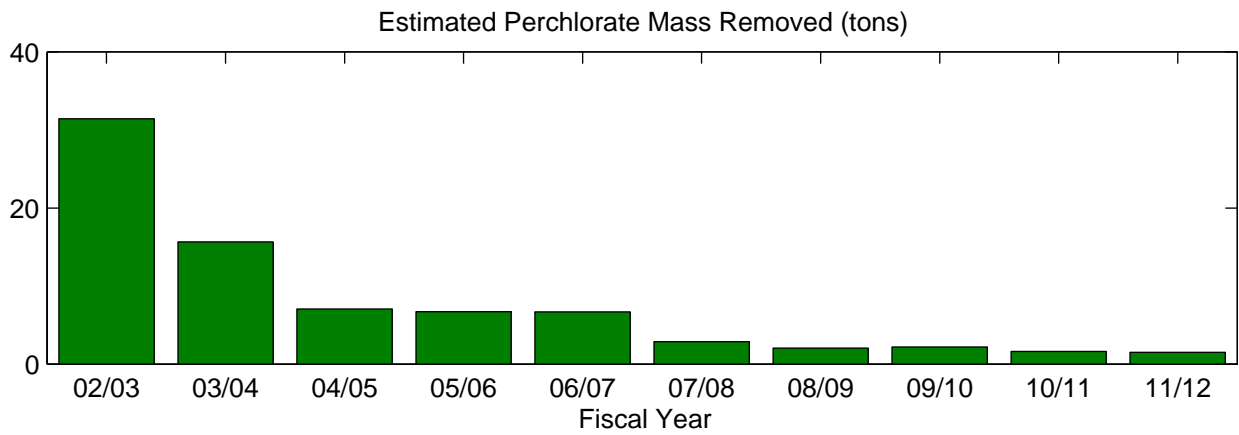
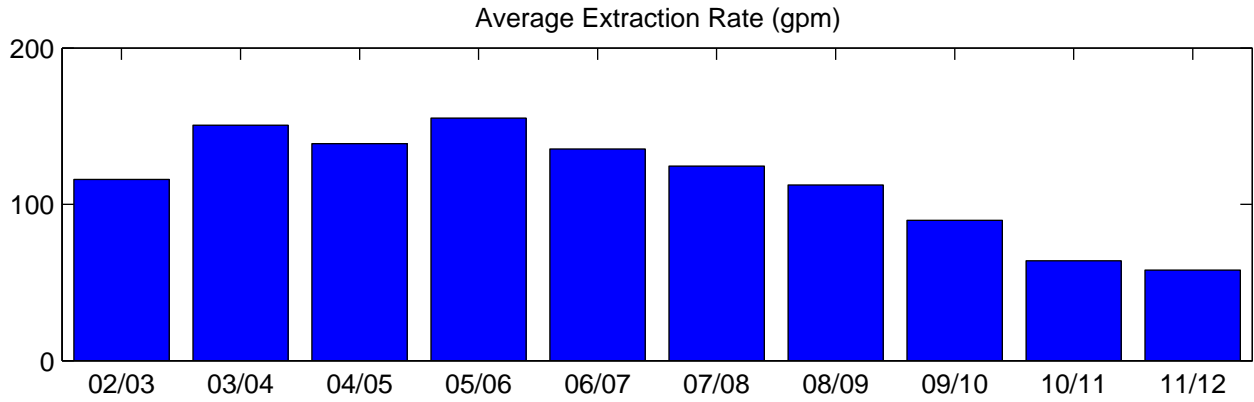
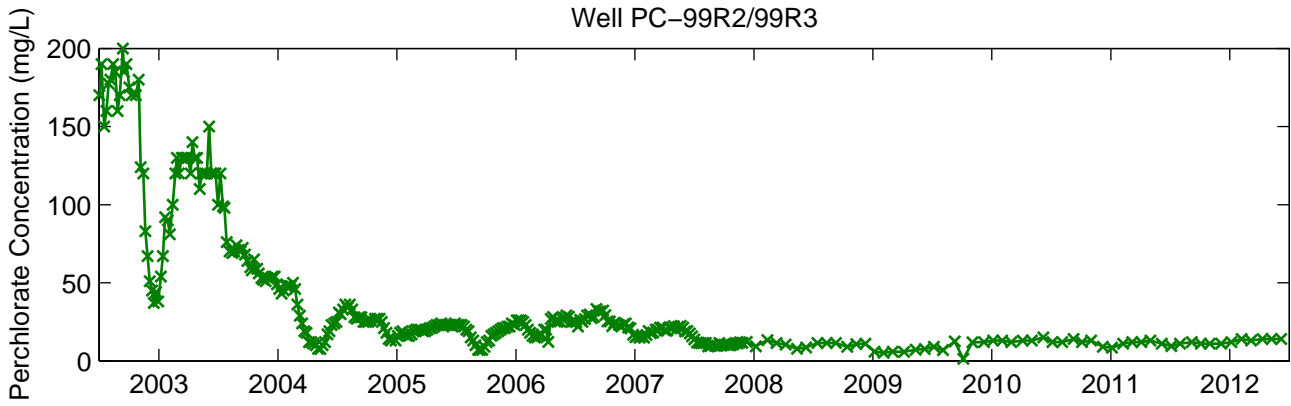

Appendix G
Community Involvement Plan
(this plan was previously submitted to NDEP
on April 30, 2012 (ENVIRON 2012a).

COMMUNITY INVOLVEMENT PLAN

DRAFT

**NEVADA ENVIRONMENTAL RESPONSE TRUST SITE
(FORMERLY TRONOX HENDERSON SITE)
HENDERSON, NEVADA**

(REVISED APRIL 30, 2012)

**Nevada Environmental Response Trust
35 East Wacker Drive – Suite 1550
Chicago, Illinois 60601**

Table of Contents

| Section | Page |
|---|------|
| Section 1.0 – Overview of the Community Involvement Plan | 1 |
| Section 2.0 – Site Description..... | 2 |
| 2.1 Site History..... | 2 |
| 2.2 Site Description/Location | 2 |
| 2.3 Site Inspections and Cleanup Activities | 3 |
| Section 3.0 – Community Background..... | 6 |
| 3.1 Community Profile..... | 6 |
| 3.2 History of Community Involvement | 6 |
| 3.3 Key Community Concerns | 7 |
| 3.4 Summary of Communication Needs | 7 |
| Section 4.0 – NERT’s Community Involvement Program | 9 |
| 4.1 Community Involvement Activities | 9 |
| 4.2 Time Frame Summary for Community Involvement Activities | 12 |

Figures

- Figure 1 Site Location Map
- Figure 2 Site Features

Appendices:

- A NERT and NDEP Contacts
- B Local Officials
- C State Officials
- D Federal Elected Officials
- E Repository Locations

Section 1.0 – Overview of the Community Involvement Plan

The Nevada Environmental Response Trust (“NERT”) developed this Community Involvement Plan (“CIP”) to guide the facilitation of communication between the community surrounding the Nevada Environmental Response Trust Site (the “Site”) with the Nevada Division of Environmental Protection (“NDEP”) and NERT and to encourage community involvement in Site activities. NERT will utilize the community involvement activities outlined in this plan to ensure that the community is informed and provided opportunities for input.

This CIP addresses the relationship with the community, provides a background of the community, presents the community involvement program of NERT, and provides a listing of resources available. NERT drew upon several information sources to develop this plan, including input received from the community, public information, and site files. The NDEP will oversee implementation of the community involvement activities outlined in this Plan.

Section 2.0 – Site Description

2.1 Site History

The Site is located within the Black Mountain Industrial (BMI) complex, an industrial complex that has had operations since 1942. The BMI complex was originally sited and operated by the United States (U.S.) government as a magnesium production plant in support of the World War II effort. Following the war, a portion of the complex was leased by Western Electrochemical Company (WECCO). By August 1952, WECCO had purchased several portions of the complex, including six of the large unit buildings, and produced manganese dioxide, sodium chlorate, and various perchlorates. In addition, in the early 1950s, pursuant to a contract with the U.S. Navy, WECCO constructed and operated a plant to produce ammonium perchlorate on land purchased by the U.S. Navy. In 1956, WECCO merged with American Potash and Chemical Company (AP&CC) and continued to operate the processes with the Navy's continued involvement in the ammonium perchlorate process. In 1962, AP&CC purchased the ammonium perchlorate plant from the Navy but continued to supply the Navy and its contractors material from the operating process. AP&CC merged with Kerr-McGee Corporation (Kerr-McGee) in 1967. As part of this merger, boron production processes in California were moved to Henderson. In the early 1970s, the boron operations, which included the production of elemental boron, boron trichloride and boron tribromide, began at the Site. In 1994, the boron tribromide process was shut down and dismantled. In 1997, the sodium chlorate process was shut down and in 1998, production of commercial ammonium perchlorate ended as well. The ammonium perchlorate production equipment was used to reclaim perchlorate from on-site materials until early 2002, when the equipment was permanently shut down.

In 2005, Kerr-McGee Chemical Corporation's name was changed to Tronox LLC. Tronox LLC filed for bankruptcy in 2009. The NERT was established through the resolution of the Tronox LLC bankruptcy. NERT is the owner of the property that was previously owned by Tronox LLC. Tronox LLC leases back a portion of the Site from the NERT for production of manganese dioxide, boron trichloride and elemental boron.

2.2 Site Description/Location

The Site is approximately 450 acres in size and is located 13 miles southeast of Las Vegas, Nevada in an unincorporated section of Clark County, Nevada. It is completely surrounded by the incorporated area of the City of Henderson (See Site Location Map Figure 1).

The Site is surrounded by industrial, commercial, and residential properties. The nearest surface water is the Las Vegas Wash, which is located approximately 3.35 miles to the north-northeast. The Las Vegas Wash discharges to Lake Mead, which is located approximately 8.6 miles to the northeast and beyond Lake Las Vegas. The location of the Site relative to surrounding industrial, commercial, and residential properties is provided on Figure 1.

The nearest residential community is located approximately 480 feet south of the site property line. The nearest health facility is located 1 mile to the east of the Site.

2.3 Site Inspections and Cleanup Activities

A groundwater investigation was initiated by Kerr-McGee in July 1981 to comply with the federal Resource Conservation and Recovery Act (“RCRA”) standards for monitoring the existing on-site impoundments. The following presents a summary of the events that followed the 1981 groundwater investigation.

- In December 1983, NDEP requested that Kerr-McGee investigate the extent of chromium impacts in the groundwater beneath the facility.
- A Consent Order between Kerr-McGee and NDEP, prepared in September 1986, stipulated additional groundwater characterization and the implementation of remedial activities to address chromium in the groundwater.
- Monitoring wells, groundwater interceptor wells, a groundwater treatment system for chromium reduction and two treated-groundwater injection trenches were installed and the treatment of groundwater began in mid-1987. This treatment is on-going today although the injection trenches are not currently utilized.
- In April 1991, Kerr-McGee was one of six companies that entered into a Consent Agreement with the NDEP to conduct environmental studies to assess site-specific environmental conditions, which are the result of past and present industrial operations and waste disposal practices. The six companies (Basic Management, Inc., Tronox, Montrose Chemical Corporation, Pioneer Americas, LLC, Titanium Metals Corporation, and Rhone-Poulenc Ag) that entered into the Consent Agreement included those past or present entities that conducted business within the BMI complex. The Consent Agreement specified that, among other things, the companies identify, document or address soil, surface water, groundwater or air impacts and document measures that have been taken to address environmental impacts from their respective sites.
- In April 1993, in compliance with the 1991 Consent Agreement, Kerr-McGee submitted the Phase I Environmental Conditions Assessment (“ECA”) to NDEP. The purpose of the report was to identify and document site-specific environmental impacts resulting from past or present industrial activities. The Phase I ECA included an assessment of the geologic and hydrologic setting, as well as then-current and historical manufacturing activities.
- In 1994, the NDEP issued a letter of understanding (“LOU”) that identified 69 data gap areas that needed additional information, either in the form of additional document research or field sampling of site conditions.
- During the mid to late 1990s, Kerr-McGee collected additional data to fill the LOU identified data gaps. This was done by investigating past operator records as well as through field sampling. Results of this work are described in the Phase II Written Response to the LOU (1996), the Phase II ECA (1997), and the Supplemental Phase II ECA (2001), the latter two of which were reports describing the results of field sampling of groundwater and soils. Through this effort, potential environmental impacts associated with the 69 LOU data gap areas were evaluated.

- In 1997, perchlorate was discovered in vicinity of the Las Vegas Wash. As a result, this aspect of the ECA was placed on a remedial fast-track.
- In the late 1990s, an impact characterization and treatment methodology evaluation was performed. Concurrently, a seep water collection system was installed adjacent to the Las Vegas Wash to mitigate the discharge of perchlorate, and a temporary ion exchange (“IX”) treatment system was installed. The groundwater treatment process began operation in November 1999.
- Kerr-McGee and NDEP entered into a 1999 Consent Agreement, which defined response requirements and looked forward to a treatment process that would replace the temporary IX. After considerable research and process development, fluidized bed reactors were developed and installed for treatment of perchlorate.
- Kerr-McGee and NDEP entered into an October 2001 Administrative Order on Consent (“AOC”) defining the current response requirements, which included additional extraction well systems and the construction of the on-site groundwater treatment facility. These systems were installed by Kerr-McGee.
- In addition, pursuant to this Order, Kerr-McGee completed the existing off-site Athens Road Well Field (AWF), the off-site Seep Well Field (SWF), and the associated on-site treatment system. The AWF, completed in 2002, consists of a series of 14 groundwater extraction wells at seven paired well locations that span roughly 1,200 feet of the alluvial paleochannels and pump from the shallow zone at a combined rate of approximately 280 gallons per minute (gpm).
- NERT currently operates the groundwater treatment facility, which includes the following primary unit operations: granular activated carbon, biological fluidized bed reactors, and a ferrous sulfate chemical precipitation system. Following treatment, all extracted water is discharged to Las Vegas Wash under a National Pollutant Discharge Elimination System (NPDES) permit. Remedial performance reports are submitted semi-annually to the NDEP.
- In 2004, a list of site-related chemicals was developed based upon then-current and historic operations information and on-Site soil and groundwater investigation analytical results. This list included but was not limited to raw materials, process chemicals, intermediates, and products of all current and previous manufacturers at the site.
- In 2005, a Conceptual Site Model (“CSM”) was prepared for the Site, which consolidated and evaluated information about known and potential environmental impacts.
- Based on data gaps identified in the investigation data results and CSM, Tronox implemented two soil sampling programs (known as Phase A and B Source Investigations) that were completed in 2006 and 2008, respectively. These investigations identified a number of constituents in excess of Nevada Basic Comparison Level (BCL) criteria within the upper 10 feet of soil, including dioxins/furans TEQ, hexachlorobenzene, other semivolatile organic compounds (SVOCs), polychlorinated biphenyls (PCBs), asbestos, metals, organochlorine pesticides (OCPs), and perchlorate.

- In an Order dated December 14, 2009, NDEP directed Tronox to remove all contaminated soil (within the vertical interval extending to a depth of 10 feet below ground surface) from the Site by the end of 2010. For the purposes of soil removal activities, the main contaminated portions of the Site were divided into the five separate remediation zones indicated on Figure 2 (Site Features) and listed below:
 - RZ-A: the southern portion of the Site
 - RZ-B: the area around the Unit buildings
 - RZ-C: the ammonia perchlorate production area, Koch Materials area, pond and diesel storage tank area, and manganese tailings area
 - RZ-D: the Trade Effluent ponds and ammonium perchlorate pad/drum recycling area (including the hazardous waste landfill)
 - RZ-E: the Beta Ditch

Soil sampling in RZ-A did not identify soils exceeding NDEP cleanup criteria so there was no excavation performed.

- In the May 28, 2010 Remedial Action Work Plan (RAW), Tronox proposed the strategy for excavating chemically impacted soil within the upper 10 feet of soil in areas RZ-B through RZ-E, to the extent such soils were accessible. These remediation activities commenced during 2010 and were completed in 2011 by NERT.
- In 2010, Tronox began evaluation of alternatives for the enhanced control/treatment of perchlorate migrating in groundwater downgradient from the AWF to reduce the need for extraction in the SWF (about 90% of the total water throughput treated in the on-site water treatment plant is extracted from the SWF) and minimize the chance for perchlorate to migrate into Las Vegas Wash. One such alternative would be installation of an *in-situ* permeable reactive barrier (PRB).
- As of January 1, 2012, approximately 930,000 tons of contaminated soil and related materials had been excavated. Certain impacted soils within the remediation zones, which could not be excavated due to physical constraints or other access issues, are being addressed through Institutional Controls / Environmental Covenants.
- Recent groundwater monitoring results indicate significant capture and ongoing reduction of the perchlorate and hexavalent chromium plumes. Perchlorate loading into Las Vegas Wash has declined by nearly 94% over the last 10 years of groundwater capture system operation. The groundwater extraction and treatment system continues to operate.

Section 3.0 – Community Background

3.1 Community Profile

The Site is located in Henderson, Nevada, a suburban city in Clark County, Nevada, United States, within the Las Vegas metropolitan area of the Mojave Desert. It occupies the southeast end of the Las Vegas Valley. The total land area of Henderson is 107.33 square miles with a population density of 2,392.3 persons per square mile. Until recent years, Henderson was one of the fastest growing cities in the nation.

Henderson is the second largest city in Nevada, after Las Vegas, with an estimated population of 257,729 in the 2010 census. This represents a 47 percent increase over the 2000 Census population. Census 2010 data show that Henderson is 76.8 percent White, 14.9 percent Hispanic, 7.2 percent Asian and 5.1 percent Black. The median household income was \$68,039 and 7.3 percent of the population lived below the poverty line. As of 2010, the unemployment rate was 13.8 percent. 22.6 percent of the Henderson population in 2010 was under 18, while 14.3 percent was 65 and older.

Henderson had 24,846 businesses as of the 2010 Census. In 2010, the largest employer was the City of Henderson with 2,963 employees. Four of the top ten employers were businesses in the tourism, gaming and entertainment industry. Two of the top ten employers were hospitals.

The public school system in Henderson is organized under the Clark County School District. Of the public schools serving Henderson, there are 26 elementary schools, 9 junior high/middle schools, and 9 high schools. There are also 4 charter schools and 5 private schools. With specific relevance to the NERT site, Hinman Elementary School is located approximately three-quarters of a mile north/northeast of the Site and in the direction of Las Vegas Wash.

There are 10 golf courses in Henderson, as well as 54 city parks on more than 1,260 acres. Henderson also boasts over 65 linear miles of walking and running trails. In regards to the NERT site, three parks are located between the site and the Las Vegas Wash: Rodeo Park, Henderson Bird Viewing Preserve, and Wells Park and Pool.

3.2 History of Community Involvement

A previous Community Involvement Plan was implemented for the Site by Tronox and NDEP has maintained a public website with various site-related documents and related information since 2006. Information repositories were also previously established for the Site at the City of Henderson public library and the NDEP Las Vegas and Carson City offices. Although the library was subsequently demolished, information and documents continue to be available at the NDEP Las Vegas office. In addition, NDEP has held several stakeholder meetings for interested community residents and local authorities that were open to the public, distributed fact sheets related to the Site, and disseminated information regarding the site to the local media.

NERT has communicated site developments and collected input from the community using an interview questionnaire that was mailed to community members residing within 1 mile of the Site. The mailing included distribution of a current fact sheet. Furthermore, NERT held two Community Interview Meetings on April 23, 2012. Notification of the meetings was made with direct mailings to the NERT mailing list which included more than 4000 names and placement of a notice in in two papers, the Las Vegas Review Journal and The Henderson Press (twice).

NERT and NDEP participate in quarterly stakeholder calls. The calls occurred on a monthly basis through a majority of 2011. NERT has also maintained open communications to interested parties such as the Henderson Industrial Community Advisory Panel which includes representatives of the community such as local residents, business owners, and a school principal, along with representatives of nearby industries, police, fire, community development, and the Chamber of Commerce.

3.3 Key Community Concerns

The following is a summary of key community concerns identified through the use of the Community Interview Questionnaire and the public meeting.

- Risk to public health through exposure to releases from the Site that may have occurred historically, or are currently occurring under existing permits. The public expressed concerns regarding historical releases that may have impacted soil areas which are now residential properties or groundwater impacts that have been detected off the NERT property.
- Information regarding site related chemicals and the potential risk of site related chemicals to the surrounding community.
- Information regarding the fate and transport of chemicals from the Site including the treatment processes employed by the existing groundwater treatment system.
- Information regarding the project schedule and the plan for future Site work.
- Cost of remediation and who is paying for the cleanup.
- Air quality and information regarding what chemicals may be released from the larger BMI complex site.
- Staining noted on sidewalks and property at off-site believed to originate from the NERT site or the larger BMI complex site.
- Concerns were expressed regarding the potential deposition of impacted soil in adjacent properties, as well as health affects related to inhalation of dust from the site, both historically, due to the soil contamination, as well as currently, due to both the soil contamination that remains and the BMI complex air emissions.
- Levels of perchlorate in groundwater.
- Remediation of other properties in the BMI complex.

3.4 Summary of Communication Needs

NERT will continue to provide routine updates to the public through mailings (including electronic mail) and public meetings. Mailings will include fact sheets (at least annually) and updates at critical stages of the project or as requested by the community. For example, the surrounding community will be informed when the remedial investigation has been completed and the report approved by the NDEP.

As required by Title 40 of the Code of Federal Regulations (CFR) Part 25, public meetings and public hearings will be held at project milestones such as publication of the Proposed Remedial Action Plan (PRAP). Meetings will be held at times and places which, to the maximum extent feasible, facilitate attendance by the public. As with the April 23, 2012 Community Interview Meeting, more than one meeting may be held to facilitate public participation. Public meetings,

which are less formal than public hearings, do not require formal presentations, scheduling of presentations and a record of proceedings. Notice of public meetings and hearing will not be less than 30 days.

Section 4.0 – NERT’s Community Involvement Program

The overall goal of NERT’s community involvement program is to promote two-way communication between citizens and NERT and to provide opportunities for meaningful and active involvement by the community in the cleanup process. NERT will implement the community involvement activities described below. The following plan is based on the results of the community interviews described earlier; it addresses each issue that was identified as being important to the community. The identified issues include:

- Designate a Community Involvement Coordinator (CIC).
- Prepare and distribute Site fact sheets and technical summaries.
- Maintain a mailing list for the Site.
- Establish and maintain information repositories.
- Place Site information on the internet.
- Establish and maintain the Administrative Record.
- Hold public meetings or public availability sessions.
- Revise the Community Involvement Plan (CIP).

4.1 Community Involvement Activities

The following highlights community involvement activities associated with this plan.

Designation of Community Involvement Coordinator (CIC)

- Objective: The CIC will be the primary liaison between the community and the NDEP and NERT, and will ensure prompt, accurate, and consistent responses and information dissemination about the Site. In those instances where the CIC may be unable to provide adequate information (such as on technical issues), inquiries will be directed to the appropriate NERT contact.
- Method: The CIC appointed is Shannon Harbour, Supervisor Special Projects Branch of the NDEP. She will work closely with Allan DeLorme of ENVIRON, NERT’s technical lead for the Site.
- Timing: The CIC was designated on June 2012.

Prepare and distribute fact sheets and technical summaries

- Objective: To provide citizens with current, accurate, easy-to-read, easy-to-understand information about the NERT site.
- Method: Fact sheets will be mailed to parties on the Site mailing list. In addition, copies will be available at the information repository and on the NDEP website for the NERT site.
- Timing: NERT and NDEP will prepare and distribute fact sheets at least once per year or more frequent, if appropriate, to communicate site activities.

Maintain a mailing list for the Site

- Objective: To facilitate the distribution of site-specific information to everyone who needs or wants to be kept informed about the Site.
- Method: NERT in cooperation with NDEP will create a mailing list that includes all residences adjacent to the Site, in known or suspected paths of migration, or those otherwise affected by the Site.
- Timing: NERT will review and update the mailing list annually.

Establish and maintain Information Repositories

- Objective: To provide a convenient location where residents can go to read and copy official documents and other pertinent information about the Site.
- Method: The repository is a reference collection of site information containing the Administrative Record file and other site-specific information. The NDEP will maintain a repository at the NDEP office in Las Vegas and the local Information Repository at the James I. Gibson Library on Lake Mead Parkway in Henderson, Nevada.
- Timing: NERT and NDEP will establish the local repository within 90 days of the date of the CIP.

Site Information on the Internet

- Objective: To provide key resources for searching and listing both general and specific information about the Site.
- Method: A Site Status Summary for this site can be found at <http://ndep.nv.gov/bmi/tronox.htm>.
- Timing: Site Status Summaries are updated annually.

Establish and maintain the Administrative Record

- Objective: To provide residents with Site documents, resources, etc. used by NERT and the NDEP in reaching all decisions about the Site and its cleanup.
- Method: NDEP will provide at least two sets of the Administrative Record for the Site, one in the NDEP office in Las Vegas, Nevada and one located in the local Information Repository near the Site.
- Timing: The NDEP repository at the NDEP office in Las Vegas is complete and the local Information Repository is currently being established at the James I. Gibson Library on Lake Mead Parkway in Henderson, Nevada. Documents prepared by NERT will be added to the local repository within 60 days of their submittal and approval by NDEP.

Hold public meetings or public availability sessions

- Objective: To update the community on Site developments and address community questions, concerns, ideas and comments.
- Method: NDEP and NERT will schedule, prepare for, and attend all announced meetings or availability sessions. At least two weeks' notice of the scheduled meeting will be provided to the community. The CIC and other appropriate NDEP staff and representatives of NERT will attend.

- Timing: A public availability session was held on April 23, 2012 at the Henderson Convention Center, 200 South Water Street, Henderson, Nevada. NDEP and NERT will hold other public meetings as appropriate.

Revise the Community Involvement Plan (CIP)

- Objective: To identify and address community needs, issues, or concerns regarding the Site or the cleanup remedy that are identified after the publication of this CIP.
- Method: A Revised CIP will update the information presented in the previous version of the CIP.
- Timing: NERT in cooperation with NDEP will revise the CIP as community input warrants or at least every three years until the Site is closed out.

4.2 Time Frame Summary for Community Involvement Activities

| Activity | Time Frame |
|--|---|
| Designate CIC | |
| Prepare and distribute fact sheets and technical summaries | Initially in 2011 and updated as needed |
| Maintain a mailing list for the Site | Updated March 2012 and updated at least annually |
| Establish and maintain Information Repositories | Established at NDEP in Las Vegas, Nevada. A second location to be established at the James I. Gibson Library in Henderson, NV |
| Provide Site information on the Internet | As Needed |
| Establish and maintain Administrative Record | Established at NDEP in Las Vegas, Nevada. A second location to be established at the James I. Gibson Library in Henderson, NV |
| Hold public meetings or availability sessions | As needed |
| Revise the CIP | As needed but no less frequent than every 3 years |

Figures

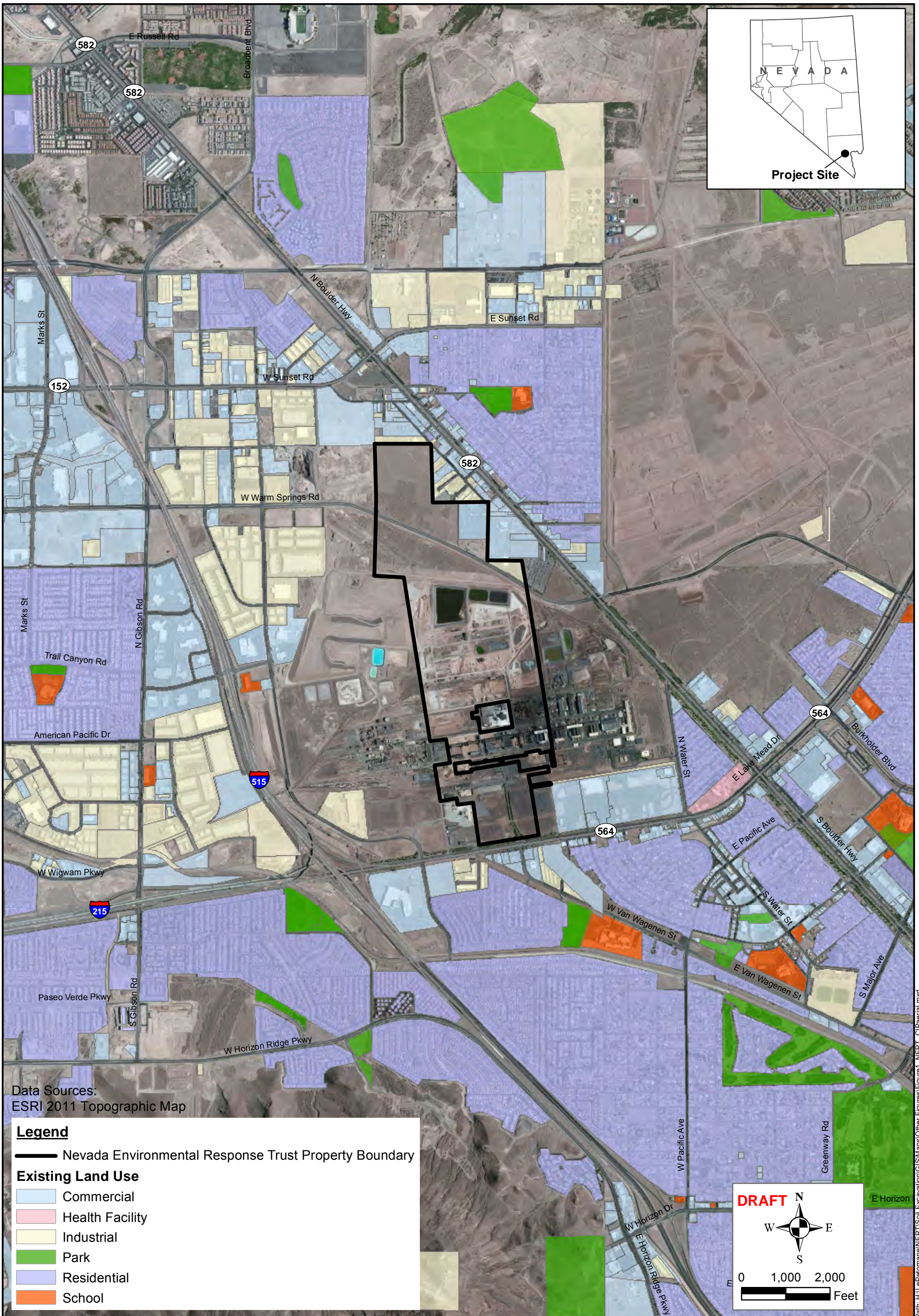

Data Sources:
ESRI 2011 Topographic Map

Legend

— Nevada Environmental Response Trust Property Boundary

Existing Land Use

- Commercial
- Health Facility
- Industrial
- Park
- Residential
- School

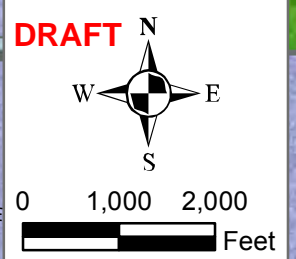

6001 Shellmound St., Suite 700, Emeryville, CA 94608

Site Location Map

Nevada Environmental Response Trust Site, Henderson, Nevada

Drafter: EA

Date: 2/24/12

Contract Number: 21-29100

Approved by: DR

Figure

1

Revised:

Path: H:\LerPei\mane\NER\Soil_Excavation\GIS\Maps\Other Figures\Figure_1_NERT_CIPaerial.mxd

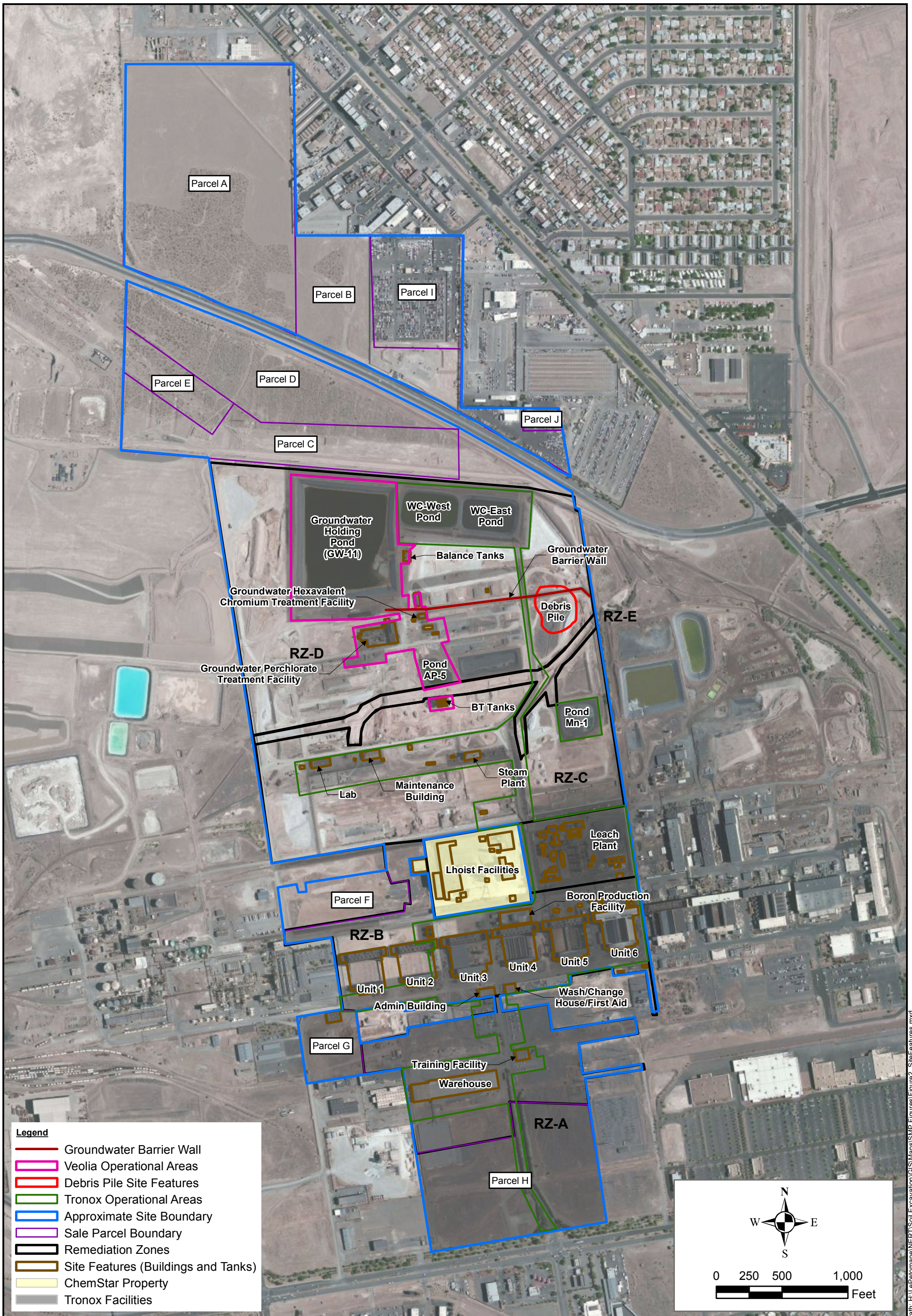

Path: H:\Lepetomane\NER\T\S\Excavation\GIS\Maps\SMP_Figures\Figure2_SiteFeatures.mxd

**Appendix A
NERT and NDEP Contacts**

NDEP

Shannon Harbour, P.E.
Community Involvement Coordinator
Supervisor, Special Projects Branch
Bureau of Corrective Actions
NDEP-Carson City Office
901 S Stewart St
Carson City, NV 89701
Phone: (775) 687-9332

Greg Lovato
Chief, Bureau of Corrective Actions
NV Division of Environmental Protection
Bureau of Corrective Actions
NDEP-Carson City Office
901 S Stewart St
Carson City, NV 89701
Phone: (775) 687-9373

NERT

Jay A. Steinberg, not individually, but solely
as President of the Nevada Environmental
Response Trust Trustee
35 East Wacker Drive - Suite 1550
Chicago, Illinois 60601
Phone: (312) 505-2688

Andrew Steinberg
Vice President, Operations
LePetomane, Inc.
35 E Wacker Dr., Suite 1550
Chicago IL 60601
Phone: (312) 498-2800

Allan DeLorme
Managing Principal
ENVIRON International Corporation
2200 Powell Street, Suite 700
Emeryville, CA 94608
Phone: (510) 420-2565

John Pekala
Senior Manager
ENVIRON International Corporation
1702 E. Highland Ave. #412
Phoenix, AZ 85016
Phone: (602) 734-7710

**Appendix B
Local Officials**

Mayor Andy A. Hafen
Telephone (702) 267-2406

City Council Members
Council Ward I – Gerri Schroder
Council Ward II – Debra March
Council Ward III – John F. Marz
Council IV – Sam Bateman
City Council Offices (702) 267-2085

Southern Nevada Health District
P.O. Box 3902
Las Vegas, NV 89127
Telephone (702) 759-1000

Fire Department
Telephone (702) 267-2222

Police Department
223 Lead Street
Henderson, NV 89015
Telephone (702) 267-5000

Appendix C State Officials

Governor Brian Sandoval

R-(4-year term expires in 2014)
555 E. Washington Ave., Suite 5100
Las Vegas, NV 89101
(702) 486-2500 (o)
(702) 486-2505 (f)

State Capitol Building
101 N. Carson Street
Carson City, NV 89701
(775) 684-5670 (o)
(775) 684-5683 (f)
www.gov.state.nv.us

Lt. Governor Brian K. Krolicki

R- (4-year term expires in 2014)
555 E. Washington Ave., Suite 5500
Las Vegas, NV 89101
(702) 486-2400 (o)
(702) 486-2404 (f)

State Capitol Building
101 N. Carson Street
Carson City, NV 89701
(775) 684-7111 (o)
(775) 684-7110 (f)
<http://ltgov.nv.gov/>

Clark County Commissioner Steve Sisolak

D–District A (4-year term expires in 2012)
500 Grand Central Parkway, 6th Floor
Las Vegas, NV 89106
(702) 455-3500 (o)
(702) 383-6041 (f)
ccdista@co.clark.nv.us
www.accessclarkcounty.com/depts/countyc_ommissioners/districta/Pages/default.aspx

Clark County Commissioner Mary Beth Scow

D–District G (4-year term expires in 2014)
500 Grand Central Parkway, 6th Floor
Las Vegas, NV 89106
(702) 455-3500 (o)
(702) 383-6041 (f)
ccdista@co.clark.nv.us
www.accessclarkcounty.com/depts/countyc_ommissioners/districtg/Pages/default.aspx

**Appendix D
Federal Elected Officials**

U.S. Senator Harry Reid

D–Nevada (6-year term expires in 2017)
Lloyd George Federal Building
333 S. Las Vegas Blvd., Suite 8016
Las Vegas, NV 89101
(702) 388-5020 (o)
(702) 388-5030 (f)

528 Hart Senate Office Building
Washington, DC 20510
(202) 224-3542 (o)
(202) 224-7327 (f)
www.reid.senate.gov

U.S. Senator Dean Heller

R–Nevada (6-year term expires in 2013)
Lloyd George Federal Building
333 South Las Vegas Blvd., Suite 8203
Las Vegas, NV 89101
(702) 388-6605 (o)
(702) 388-6501 (f)

361-A Russell Senate Office Building
Washington, DC 20510
(202) 224-6244 (o)
(202) 228-6753 (f)
<http://heller.senate.gov>

U.S. Representative Shelley Berkley

D–Nevada District 1 (2-year term expires in 2012)
2340 Paseo Del Prado, Suite D-106
Las Vegas, NV 89102
(702) 220-9823 (o)
(702) 220-9841 (f)

405 Cannon House Office Building
Washington, DC 20515
(202) 225-5965 (o)
(202) 225-3119 (f)
(877) 409-2488 toll free
www.berkley.house.gov

U.S. Representative Mark Amodei

R–Nevada District 2 (2-year term expires in 2012)
600 Las Vegas Blvd. South, Suite 680
Las Vegas, NV 89101
(702) 255-1651 (o)
(702) 255-1927 (f)

125 Cannon House Office Building
Washington, DC 20515
(202) 225-6155 (o)
(202) 225-5679 (f)
www.amodei.house.gov

U.S. Representative Joe Heck

R–Nevada District 3 (2-year term expires in 2012)
8485 W. Sunset Road, Suite 300
Las Vegas, NV 89113
(702) 387-4941 (o)
(702) 837-0728 (f)

132 Cannon HOB
Washington, DC 20515
(202) 225-3252 (o)
(202) 225-2185 (f)
www.heck.house.gov

Appendix E Repository Locations

Local Repository:

Nevada Division of Environmental Protection
2030 E. Flamingo Rd. Suite 230
Las Vegas NV 89119

James I. Gibson Library
100 W Lake Mead Parkway
Henderson, NV 89015