

**PRELIMINARY REPORT ON A HYDROGEOLOGIC
INVESTIGATION OF CHANNEL-FILL ALLUVIUM
AT THE PITTMAN LATERAL
HENDERSON, NEVADA**

October 19, 1998

**KERR-McGEE CHEMICAL LLC
HENDERSON, NEVADA FACILITY**



KERR-McGEE CHEMICAL LLC

POST OFFICE BOX 55 - HENDERSON, NEVADA 89009

October 30, 1998

Ms. Brenda Pohlmann
Remediation Branch Supervisor
Nevada Division of Environmental Protection
555 E. Washington, Suite 4300
Las Vegas, NV 89101

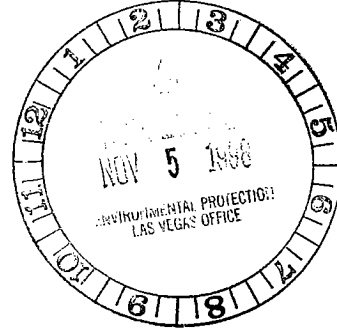

Dear Ms. Pohlmann:

Subject: PC-70 Pump Test Results

Attached are two copies of the PC-70 pump test results. This information will assist KMCLLC in evaluating remedial measures for perchlorate impact.

KMC is committed to act responsibly and cooperate fully with local, state, and federal officials in determining appropriate remedial actions. Please feel free to contact me at (702) 651-2200 if you have any questions related to this information. Thank you.

Sincerely,

Susan M. Crowley
Staff Environmental Specialist

By certified mail

cc: PSCorbett w/o attachment
EMSpore w/o attachment
TWRreed w/o attachment
WOGreen w/o attachment
RHJones w/o attachment
LKBailey w/o attachment
ALDooley w/o attachment
Robert Kelso (NDEP) w/o attachment
Doug Zimmerman (NDEP) w/o attachment
MWD
Barry Conaty, COH
Pat Mulroy, SNWA
Kevin Meyer, EPA Region IX

smclPC70 Report to Pohlmann.doc

**PRELIMINARY REPORT ON A HYDROGEOLOGIC
INVESTIGATION OF CHANNEL-FILL ALLUVIUM
AT THE PITTMAN LATERAL
HENDERSON, NEVADA**

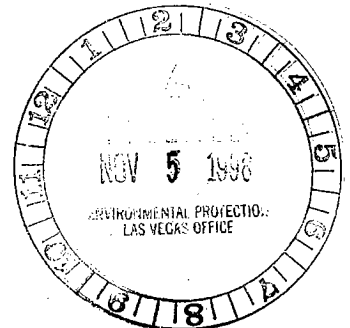

**KERR-McGEE CHEMICAL LLC
HENDERSON, NEVADA FACILITY**

**Prepared by
Steven R. Lower
Hydrology Services Group
Assessment and Remediation Department
Kerr-McGee Safety and Environmental Affairs Division**

October 19, 1998

TABLE OF CONTENTS

EXECUTIVE SUMMARY

INTRODUCTION	1
Hydrogeology of the Pittman Lateral Test Site and Vicinity.....	2
DRILLING AND LOGGING OF THE PC-70 TEST BORING	4
Lithology of the Channel-fill Alluvium at the Pittman Lateral Test Site	4
Grain Size Distribution in the Channel-Fill Alluvial Sequence	6
CONSTRUCTION AND DEVELOPMENT OF TEST WELL PC-70	6
TEST OF PITTMAN LATERAL WELL PC-70	10
Descriptions of the Test and Observation Wells.....	10
Descriptions of Water-Level Fluctuations in the Alluvium.....	12
Description of the Pittman Lateral Aquifer Test.....	14
Description of the Calibration Test	15
Description of the Test.....	16
ANALYSES OF PC-70 AQUIFER TEST DATA	17
Calculations of Aquifer Coefficients.....	19
Jacobs Semi-Log Straight-Line Analyses of Drawdown Data.....	20
Theis Log-Log Type Curve Match Analyses of Drawdown Data ...	20
Boulton Log-Log Delayed Drainage Curve Match Analyses of Drawdown Data	20
Jacobs Semi-Log Straight-Line Analyses of Recovery Data	21
Jacobs Semi-Log Straight-Line Analyses of Distance-Drawdown Data.....	22
Estimation of Test Well Efficiency from Distance-Drawdown Data	22
CONCLUSIONS	23
REFERENCES CITED	26
ADDENDA	
ADDENDUM A Lithologic Logs for Test Well PC-70 and Observation Wells PC-17, PC-18, and PC-55	
ADDENDUM B Dames and Moore Report on PC-70 Test Boring Grain-Size Analyses	

TABLE OF CONTENTS (continued)

ADDENDA (continued)

ADDENDUM C	Well Construction Diagrams for Test Well PC-70 and Observation Wells PC-17, PC-18, and PC-55
ADDENDUM D	Tabulations and Graphs of Drawdown and Recovery Data and Calculations of Aquifer Coefficients for Test Well PC-70
ADDENDUM E	Tabulations and Graphs of Drawdown and Recovery Data and Calculations of Aquifer Coefficients for Test Well PC-17
ADDENDUM F	Tabulations and Graphs of Drawdown and Recovery Data and Calculations of Aquifer Coefficients for Test Well PC-18
ADDENDUM G	Tabulations and Graphs of Drawdown and Recovery Data and Calculations of Aquifer Coefficients for Test Well PC-55
ADDENDUM H	Graphs of Distance-Drawdown Analyses and Calculations of Corresponding Aquifer Coefficients
ADDENDUM I	Projection of Well Efficiency for Test Well PC-70

LIST OF TABLES

Tables

1.	Grain Size Distribution in the Alluvial Sequence Pittman Lateral Test Well PC-70	7
2.	Pittman Lateral Water Levels	13
3.	Compilation of Pittman Lateral Aquifer Coefficient Data	18

LIST OF FIGURES

Figure

1.	Grain Size Gradation Curves for Test Boring Sediment Samples Pittman Lateral Test Well PC-70
2.	Growth of the Drawdown Cone at 100, 720, 1440, 2160, and 2880 Minutes Constant Discharge Test of Pittman Lateral Test Well PC-70

TABLE OF CONTENTS (continued)

LIST OF PHOTOGRAPHS

Photograph

1. Tan to light-brown, poorly sorted, fine-to-coarse grained sand with small gravel clasts in the depth interval 21-22 feet. Test Well PC-70 exploratory borehole, Pittman Lateral, Henderson, Nevada; 9/8/98
2. Alternating sequence of light-brown fine sand and poorly sorted gravel in the depth interval 28.5-30.5 feet. Test Well PC-70 exploratory borehole, Pittman Lateral, Henderson, Nevada; 9/8/98
3. Alternating sequence of light-brown fine sand and poorly sorted gravel in the depth interval 35-36.5 feet. Test Well PC-70 exploratory borehole, Pittman Lateral, Henderson, Nevada; 9/8/98
4. Close-up view of a portion of core showing the poorly sorted sand and gravel in the depth interval 35-36.5 feet. Test Well PC-70 exploratory borehole, Pittman Lateral, Henderson, Nevada; 9/8/98
5. Close-up of disaggregated gravel sample from the 35-36.5 foot interval showing poorly sorted grain-size distribution. Test Well PC-70 exploratory borehole, Pittman Lateral, Henderson, Nevada; 9/8/98
6. Alternating sequence of fine-to coarse-grained sand and poorly sorted gravel in the depth interval 40-42 feet. Test Well PC-70 exploratory borehole, Pittman Lateral, Henderson, Nevada; 9/8/98
7. Close-up view of the uppermost gravelly clay of the Muddy Creek in the interval 50-51 feet. Test Well PC-70 exploratory borehole, Pittman Lateral, Henderson, Nevada; 9/8/98
8. Close-up view of the 20-slot, Bort-Longyear "Circumslot" continuous-wrap PVC screen used in the construction of Test Well PC-70.. Pittman Lateral, Henderson, Nevada; 9/12/98.
9. Close-up inside view of the 20-slot, Bort-Longyear "Circumslot" PVC screen to show the internal ribbing that supports the single piece of PVC extrusion, which permits the continuous-wrap, circumferential slotting. Pittman Lateral, Henderson, Nevada; 9/12/98.
10. View of the surge block used in the development of Test Well PC-70. Pittman Lateral, Henderson, Nevada; 9/12/98.
11. View to the east at Pittman Lateral test site after the peak of the September 11, 1998 flash-flood event. Locations of Test Well PC-70 and Observation Wells PC-18 and PC-55 are shown. Pittman Lateral, Henderson, Nevada; 9/11/98.

TABLE OF CONTENTS (continued)

LIST OF PHOTOGRAPHS (continued)

Photograph

12. View to the west at Pittman Lateral test site after the peak of the September 11, 1998 flash-flood event. Location of Observation Well PC-55 is shown. Pittman Lateral, Henderson, Nevada; 9/11/98.
13. View to the east at Pittman Lateral test site after the September 11, 1998 flash-flood event. Location of Observation Well PC-55 is shown. Pittman Lateral, Henderson, Nevada; 9/11/98.
14. View of Test Well PC-70 well head showing ball valve, flow meter, and discharge line. Pittman Lateral, Henderson, Nevada; 9/14/98.
15. Close-up view of 10 gallon per minute totallizing flow meter used to measure discharge from Test Well PC-70. Pittman Lateral, Henderson, Nevada; 9/15/98.
16. View to the east showing the 350-foot run of the discharge line from the Test Well PC-70 well head to the concrete lined portion of the channel. Pittman Lateral, Henderson, Nevada; 9/15/98
17. Close-up view of the Test Well PC-70 discharge of clean water to the concrete lined portion of the channel. Pittman Lateral, Henderson, Nevada; 9/15/98.

EXECUTIVE SUMMARY

Hydrogeologic investigations were conducted in an area referred to as the Pittman Lateral in the southeast portion of the Las Vegas Valley in June and August of 1998. This area is located north of Kerr-McGee's Henderson, Nevada, facility. The purpose of the investigations was to determine the hydrogeologic characteristics of channel-fill alluvial sediments that overlie the Muddy Creek Formation at the Pittman Lateral Test Site. The results of these investigations were inconclusive.

To better quantify the hydrogeologic characteristics of the channel-fill alluvium, further hydrogeologic investigations were centered around a new well which was constructed and tested at the Pittman Lateral Test Site in September 1998. The hydrogeologic data resulting from the construction and testing of well PC-70 is the subject of this report.

Based upon the report that follows, the following conclusions can be reached regarding the hydrogeology of the channel-fill alluvium at the Pittman Lateral Test Site:

- The well was completed in Quaternary channel-fill alluvium overlying the Tertiary Muddy Creek Formation.
- The channel-fill alluvium at the Pittman Lateral Test Site was found to consist of an alternating sequence of light-brown, fine-grained sand and fine- to coarse-grained sand and gravel. The top of the Muddy Creek Formation, which was encountered at a depth of about 49 feet, was found to consist of a gravelly clay.
- An aquifer test consisting of a 48-hour constant discharge pumping test followed by 21 hours of recovery was performed at Well PC-70. Water levels were monitored in the pumping well and three observation wells.
- Drawdown and recovery data resulting from the aquifer test were analyzed using several different methodologies. Comparison of aquifer coefficients resulting from the analyses of drawdown data show very good consistency. Recovery data are not considered valid due to the effects of storm event-related recharge.
- The transmissivity of the channel-fill alluvium at the Pittman Lateral Test Site ranges from 39,666 gpd/ft to 66,000 gpd/ft, averaging 50,425 gpd/ft. These values are consistent with sand and gravels containing fine sands and silts.
- Storage coefficients were found to range from 0.03 to 0.11, averaging 0.06, which is consistent with an unconfined aquifer under water-table conditions.

PRELIMINARY REPORT ON A HYDROGEOLOGIC INVESTIGATION OF CHANNEL-FILL ALLUVIUM AT THE PITTMAN LATERAL HENDERSON, NEVADA

INTRODUCTION

In June and August of 1998, hydrogeologic investigations were conducted in an area referred to as the Pittman Lateral located north of Kerr-McGee Chemical-LLC's (Kerr-McGee) Henderson, Nevada, facility. The Pittman Lateral Test Site is located in the southeast portion of the Las Vegas Valley within the limits of the City of Henderson. The site is bounded on the north by the Henderson wastewater treatment facility and on the south by Sunset Boulevard.

The purpose of the hydrogeologic investigations was to determine the hydrogeologic characteristics of channel-fill alluvial sediments that overlie the Muddy Creek Formation. The results of those investigations were inconclusive.

To better quantify the hydrogeologic characteristics of the channel-fill alluvium, further hydrogeologic investigations were centered around a new well, PC-70, which was constructed and tested at the Pittman Lateral Test Site in September 1998. Since Test Well PC-70 was to be a groundwater production well rather than a monitor well, every effort was made in the design, construction, and development of the well to make it as efficient as possible. The hydrogeologic data resulting from the construction and testing of well PC-70 is the subject of this report.

Hydrogeology of the Pittman Lateral Test Site and Vicinity

The Las Vegas Valley occupies a topographic and structural basin which lies within the Basin and Range physiographic province. The valley is bordered by steeply rising mountains composed of igneous and sedimentary rocks. Coalescing alluvial fans slope gently from the mountains toward the valley floor. The valley itself is wide, flat, and drains southeasterly towards Lake Mead and the Colorado River. The Las Vegas Wash, a shallow, narrow stream that flows southeasterly across the valley towards Lake Mead, is the principal surface water feature in the area (Kerr-McGee Chemical LLC, 1998). A tributary of the Las Vegas Wash runs west to east close by, and parallel to, the Test Site.

The Pittman Lateral Test Site is underlain by the late Tertiary-age Muddy Creek Formation. The Muddy Creek is a valley fill deposit and has a wide range of lithologies. It consists of coarse-grained sands and gravels near the mountain front forming the southern border of the valley, becoming fine grained beneath the valley. At the Test Site itself, the Muddy Creek Formation is composed of sandy clay and silty clay with lesser amounts of clayey sand (Kerr-McGee Chemical LLC, 1998).

Younger, Quaternary-age alluvial sediments resting unconformably on the Muddy Creek Formation, are a heterogeneous, poorly sorted mixture of sand and gravel with lesser amounts of silt and clay. Boulders and cobbles are common in some areas. Due to the mode of deposition of these alluvial fan deposits, no distinct beds or units are continuous over the entire area (Kerr-McGee Chemical LLC, 1998).

The sedimentary processes that deposited the Quaternary alluvium eroded the upper surface of the Muddy Creek Formation. These sediments are of greater thickness within erosional paleochannels cut into the underlying Muddy Creek Formation and thin laterally over the interfluvial areas.

A major hydrogeologic feature of the Quaternary alluvial sediments are the sands and gravels that were deposited within channels cut into the surface of the Muddy Creek Formation at a time in the geologic past when the local base level was lower than it is now. These deposits conform to the old channel boundaries, which are characteristically linear and narrow in configuration. The sediments are thickest within the channels, and thin laterally over the interfluvial areas. The paleochannels trend roughly southwest-northeast in the area reflecting past regional drainage patterns (Kerr-McGee Chemical LLC, 1998).

Groundwater in the Las Vegas Valley in general, and at the Pittman Lateral Study Site in particular, occurs mainly in the unconsolidated sediments of the channel-fill alluvium. The hydrologic characteristics of the alluvial aquifer are typical of alluvial fan deposits, exhibiting a wide range of permeabilities over relatively short distances.

The greatest concentrations of groundwater flow are expected to be found where the paleochannels cut into the clays of the underlying Muddy Creek Formation clay have been filled with coarser-grained sediments. The importance of these channel-fill deposits is that they control the occurrence and movement of groundwater in portions of

the Las Vegas Valley. These channel-fill sediments are typically very permeable, and can transmit large quantities of groundwater in transient storage. The channel-fill deposits typically exhibit higher permeabilities than do those in the adjacent interfluvial areas (Kerr-McGee Chemical LLC, 1998).

The alluvium is a shallow aquifer, and is generally under water-table conditions. Groundwater flow through the shallow alluvial sediments is generally from south to north, ultimately discharging into the Las Vegas Wash (Kerr-McGee Chemical LLC, 1998).

DRILLING AND LOGGING OF THE PC-70 TEST BORING

Prior to construction of Test Well PC-70, a test boring was drilled at the site on September 8, 1998. The purpose of the boring was to determine the lithology of the alluvial sediments at the well site as a first step in designing the well. The sediments were sampled continuously from a depth of five feet to the total depth (52 feet) using split spoons. The samples provided a vertical section of the alluvium at the site. Representative samples of the alluvium from the intervals 20-25 feet, 30-35 feet, and 40-45 feet were selected for analysis. These samples were transmitted to Dames and Moore in Las Vegas for grain-size analyses.

Lithology of the Channel-Fill Alluvium at the Pittman Lateral Test Site

A lithologic log of Test Well PC-70 is included as Addendum A. Color photographs of selected intervals are included as Photographs 1 through 7 at the back of the report.

The Pittman Lateral Test Site extends east-west in a line perpendicular to the trend of a channel cut into the Muddy Creek Formation and filled with channel-fill alluvium. The alluvial sequence was found to consist of channel-fill sands and sand and gravel mixtures. No significant quantities of clay were found in the alluvial sediments. The top of the Muddy Creek Formation, which was encountered at a depth of about 49 feet, was found to consist of a gravelly clay.

The upper part of the channel-fill alluvium underlying the Site to a depth of 15 feet consists of light-brown, silty fine sand with some gravel. In the interval 15 feet to 26 feet the alluvium consists of poorly sorted, reddish-brown, fine- to coarse-grained sand and small gravel (see Photograph 1). The bottom two feet of this sequence is cemented and very hard. The sediments became damp at a depth of about 17 feet.

Below a depth of 26 feet, the channel-fill alluvium to the total depth consisted of an alternating sequence of light-brown, fine-grained sand and fine- to coarse-grained sand and gravel (see Photographs 2 and 3). The interlayering of the fine-grained sand and the sand and gravel appeared to be rather uniform in intervals of one to two feet.

Photographs 4 and 5 show the poorly sorted characteristic of the typical fine- to coarse-grained sand and gravel channel-fill alluvial sequence. As shown in Photograph 6, the interlayered sand and the sand and gravel sequences continued to the bottom of the alluvial sequence. Photograph 7 shows the auger bit thickly covered with the dense gravelly clay of the Muddy Creek Formation.

Grain Size Distribution in the Channel-Fill Alluvial Sequence

The PC-70 test boring sediment samples were analyzed for grain-size distribution by Dames and Moore (see Addendum B). Dames and Moore also prepared recommendations on well screen slot size and sand pack size based upon the results of the grain-size analyses.

The grain-size distributions for the three samples analyzed by Dames and Moore are summarized in Table 1 below and are plotted on Figure 1 presented at the back of the report. Review of these data show that, while the coarsest gravel clasts are found in the shallow interval 20 to 25 feet, the greatest accumulation of coarse material is found in the depth interval 30 to 35 feet.

CONSTRUCTION AND DEVELOPMENT OF TEST WELL PC-70

Test Well PC-70 was designed to both promote the efficient production of groundwater for aquifer testing purposes. Results of the aquifer test shows that the design was successful in meeting that criterion.

Test Well PC-70 was constructed on September 12, 1998, by Compliance Drilling Company of Las Vegas, Nevada. A well completion diagram is included in Addendum C. All phases of well design, construction, and development were directly supervised by S. R. Lower of Kerr-McGee's Safety and Environmental Affairs Division.

TABLE 1
GRAIN-SIZE DISTRIBUTION IN THE ALLUVIAL SEQUENCE
PITTMAN LATERAL TEST WELL PC-70
HENDERSON, NEVADA

Samples Collection Date: September 8, 1998

Grain size (inches)	USGS Classification	Cumulative Percent Retained		
		Depth Interval 20-25 feet	Depth Interval 30-35 feet	Depth Interval 40-45 feet
0.003	Very Fine Sand	89.4	94.4	95.3
0.006	Fine Sand	77.9	88.2	83.8
0.010	Medium Sand	61.3	77.4	66.0
0.017	Medium Sand	42.9	64.4	44.8
0.034	Coarse Sand	26.0	49.4	23.5
0.080	Gravel	11.8	23.2	1.9
0.190	Gravel	5.8	7.4	0.3
0.375	Gravel	1.7	1.9	0.0
0.750	Gravel	0.8	0.0	0.0

Compliance Drilling used a Mobile B-59 drilling rig to drill and complete the well using hollow-stem auger technologies. The well borehole was drilled to a total depth of 50.5 feet below grade using an 8-inch (ID) hollow stem auger with an outside diameter of 12 inches. The top of the Muddy Creek Formation was found at a depth of 49 feet below grade.

Based upon the recommendations presented in the attached Dames and Moore report, the well design called for completion using 6-inch (ID) PVC well screen with a slot opening size of 0.020-inch. To promote well efficiency, the well was completed with Bort-Longyear "Circumslot" continuous-wrap PVC screen. The use of continuous-wrap PVC screen provides 34 square inches (24%) of open area per square foot of 6-inch casing as compared to 13 square inches (9%) of open area per square foot in

conventional slotted casing. Close-up views of the continuous-wrap PVC screen are shown in Photographs 8 and 9.

Test Well PC-70 was completed to a depth of 50.5 feet below grade using 6-inch (ID), Schedule 40 PVC screw-coupled blank casing and screen. The casing string consisted of 18 feet of blank casing set in the interval 0.5 foot below grade to 18.5 feet. A total of 30 feet of the Bort-Longyear continuous-wrap PVC screen was set in the interval 18.5 feet to 48.5 feet below grade. A two-foot length of blank casing was set in the interval 48.5 feet to 50.5 feet to provide a sump to collect any fines that may be produced during well development and testing. Since the wellhead was completed below ground surface, the bottom of the casing string is at a depth of 50 feet below the top of the casing.

Following installation of the casing, the well annulus was filled with sand. The annulus between the casing and the borehole was packed with washed and sized 8-12 filter pack material from a depth of 50.5 feet to 15 feet below grade. The remainder of the annular pack and seal were not completed until after initial development had been completed.

The initial development of Test Well PC-70 was performed using a surge block. A picture of the surge block used is shown in Photograph 10.

The surge block method of well development was chosen because of its effectiveness in eliminating damage to the borehole wall that may have been caused by drilling, thus opening the formation to the well. In addition, surge-block development stabilizes the sand in the filter pack, removing any small sand bridges in the process. On the down stroke of surge-block development, water is forced through the well screen and into the annulus, agitating the sand pack. On the up stroke, water is pulled from the formation, through the sand pack and into the well casing. This forces the agitated sand to settle and pack tightly in the annulus as it is designed to do.

During the first period of the surge-block development of Test Well PC-70, the top of the sand pack dropped from 15 feet to 20.3 feet as the sand grains packed tightly in the annulus. After the sand was brought back up to 16 feet, more surge-block development was done. The sand level dropped 1 foot, to 17 feet, during the second period of surge-block development.

Following the completion of surge-block development, the sand level was brought up to 15.5 feet. An annular seal consisting of bentonite pellets was placed in the interval 11 feet to 15.5 feet below grade and hydrated in place with clean water. The remainder of the annulus to a depth of about one foot below grade was filled with a cement/bentonite grout.

Further development of Test Well PC-70 was performed on September 14. This development work consisted of pump surging to stimulate the formation.

TEST OF PITTMAN LATERAL WELL PC-70

During the period September 14 through 17, 1998, a test of the channel-fill alluvial aquifer was performed at the Pittman Lateral Test Site. The objective of the test was to determine the hydraulic characteristics (transmissivity, permeability, storage coefficient) of the alluvial sediments that overlies the Muddy Creek Formation at the Test Site.

This aquifer test consisted of a 48-hour constant discharge pumping test of Test Well PC-70 followed by a 21-hour period of recovery. Water-level measurements were taken during the test in PC-70 and in three existing monitor wells. The test was performed by S. R. Lower of Kerr-McGee's Safety and Environmental Affairs Division, with the assistance of Tracy Williams, also with the Kerr-McGee Safety and Environmental Affairs Division, and Mark Porterfield and Shimi Mathew of the Kerr-McGee Henderson Facility.

Descriptions of the Test and Observation Wells

A total of four wells, a pumping well (Test Well PC-70) and three observation wells, were used in this aquifer test. All four wells are location along an east-west line that runs perpendicular to the trend of the alluvial channel cut into the Muddy Creek Formation. Observation Well PC-17 is located about 30 feet east of Test Well PC-70. Observation Well PC-18 is located about 60 feet west of the test well, and Observation Well PC-55 about 160 feet to the west. Lithologic logs for all of the wells are included in Addendum A. Well completion diagrams are included in Addendum C.

As described above, Test Well PC-70 is completed in the channel-fill alluvial aquifer in the interval 15.5 feet to 50.5 feet below grade. Observation Well PC-55, located 160 feet west of Test Well PC-70, is completed in the interval 11 feet to 54 feet below ground surface in channel-fill alluvium. It was constructed using 6-inch (ID) PVC blank and slotted casing set in a 12-inch borehole. A total of 40 feet of 6-inch (ID), 20-slot PVC slotted casing was run in the interval 14 feet to 54 feet below grade.

Observation wells PC-17 and PC-18 were similarly constructed in 8-inch boreholes. Observation well PC-17 is completed in the interval 8 feet to 51 feet, with a total of 40 feet of 2-inch (ID), 20-slot PVC slotted casing set in the interval 10 feet to 50 feet below grade. Observation well PC-18 is completed in the interval 9.5 feet to 52 feet, with a total of 40 feet of 2-inch (ID), 20-slot PVC slotted casing set in the interval 11.5 feet to 51.5 feet below grade.

It should be noted that review of the lithologic log for Observation Well PC-55 (see Addendum A) shows that the lithology of the channel-fill alluvium at this location is substantially different than that at the locations of Test Well PC-70 and Observation Wells PC-17 and PC-18 located to the east. The well is completed through three separate alluvial intervals representing changes in deposition. The upper zone, which consists of sand, gravel, and cobbles, extends to a depth of 25 feet. A unit consisting of clayey sand with small gravel extends to a depth of 33 feet. This unit is underlain by a third zone consisting of silty sands and gravels to the total depth.

Descriptions of Water-Level Fluctuations in the Alluvium

Water levels were measured at the Pittman Lateral Test Site for several days prior to the start of the aquifer test. These data were compared to recent historical data to establish trends and to detect any unusual water-level fluctuations. What was found was a slowly rising water level in all wells. Adding to this trend was the pronounced impact on the water levels by a storm event, which occurred three days before the pump test.

Table 2 below shows the data resulting from the Pittman Lateral water-level measurements. Between April 8 and September 8, 1998, water levels in Observation Wells PC-17 and PC-18 rose 0.93 foot and 0.31 foot, respectively. Some of this change could be attributed to water-level stabilization following well completion. However, between June 4 and September 8, water levels in Observation Wells PC-18 and PC-55 rose 0.16 foot and 0.20 foot, respectively. These latter data clearly show the effect of a wetter-than-normal summer on the alluvial aquifer at the Pittman Lateral Test Site. Between September 8 and 11, water levels in the three observation wells appear to have stabilized.

The pronounced effect of storm events on an alluvial water-table aquifer was demonstrated following a major precipitation event on the afternoon of September 11, 1998. This precipitation event, which was a flash-flood storm that dropped 0.83-inch of precipitation on the Henderson area in a matter of minutes, flooded major and local roads as well as the Pittman Lateral Test Site. Photographs of the test site showing

**TABLE 2
PITTMAN LATERAL WATER LEVELS**

Pittman Lateral Test Site
Henderson, Nevada
April through October 1998

Date	Time	PC-17		PC-18		Remarks
		Static Water Level (ft BTOC)	Rate of Rise (ft/hour)	Static Water Level (ft BTOC)	Rate of Rise (ft/hour)	
4/8/98		19.20		19.90		Well Completion Water Levels
6/4/98				19.75		June '98 Test Data
8/25/98		18.36				
9/8/98		18.27		19.59		
9/11/98	1645	18.27		19.58		2 hours after 0.83" ppt storm
9/12/98	0600	18.21	0.004	19.53	0.004	
9/12/98	1800	18.19	0.002	19.50	0.003	
9/13/98	0800	18.15	0.003	19.47	0.002	
9/13/98	1700	18.13	0.002	19.45	0.002	
9/14/98	1100	18.11	0.001	19.42	0.002	Pre-Test Static Water Levels
10/1/98	1200	17.92	0.0005	19.27	0.0004	

**TABLE 2 (continued)
PITTMAN LATERAL WATER LEVELS**

Pittman Lateral Test Site
Henderson, Nevada
April through October 1998

Date	Time	PC-55		PC-70		Remarks
		Static Water Level (ft BTOC)	Rate of Rise (ft/hour)	Static Water Level (ft BTOC)	Rate of Rise (ft/hour)	
4/8/98						Well Completion Water Levels
6/4/98		18.25				June '98 Test Data
8/25/98		18.15				
9/8/98		18.05				
9/11/98	1645	18.05				2 hours after 0.83" ppt storm
9/12/98	0600	17.98	0.005			
9/12/98	1800	17.96	0.002	18.80		
9/13/98	0800	17.91	0.004	18.77	0.002	
9/13/98	1700	17.90	0.001	18.75	0.002	
9/14/98	1100	17.87	0.002	18.73	0.001	Pre-Test Static Water Levels
10/1/98	1200	17.74	0.0003	18.57	0.0004	

flood waters in a channeled tributary to the Las Vegas Wash that parallels the test site were taken once access to the area was possible following the storm. By that time, the flood level had dropped some, permitting limited access to the site. These pictures are included as Photographs 11, 12, and 13.

Review of the water levels shown on Table 2 shows the impact of this storm event. Water-level measurements taken two hours after the storm had ended showed no effect from the floodwaters. During the three days following the September 11 storm and prior to the start of the test on September 14, water levels at the Pittman Lateral Test Site were rising at a rate ranging up to 0.005 foot per hour. The rate of water-level rise decreased to about 0.001 to 0.002 foot per hour, which amounts to 0.024 to 0.048 foot per day.

The effect of the storm on water levels had a noticeable effect on the results of the aquifer test. Water-level data collected during the recovery part of the test clearly showed the arrival of a recharge front through the alluvial sediments.

Description of the Pittman Lateral Aquifer Test

The Pittman Lateral aquifer testing program consisted of a 48-hour constant discharge pumping test of Test Well PC-70 followed by a 21-hour period of recovery. Drawdown and recovery water-level data were collected in the pumping well, Test Well PC-70, and the three observation wells PC-17, PC-18, and PC-55. The test was conducted using a 1 horsepower submersible pump powered by a trailer-mounted, diesel-powered 480 volt

generator providing 220 volts at 50 amps to the pump. The intake of the pump was set at a depth of about 45 feet below grade.

Water was delivered to the surface through 2-inch (ID) PVC pipe. Adjustments in the flow rate were made using a ball valve (see Photograph 14). The flow rate was measured using an in-line totalizing flow meter with a 10 gallon per minute (gpm) sweep (see Photographs 14 and 15). The flow rate was periodically confirmed using a two-gallon calibrated bucket and stopwatch. Water levels were monitored during the test using electric lines.

Groundwater was discharged from the well to a two-inch diameter plastic hose. Due to a concern with gravity drainage through the obviously porous alluvium, and thus the possibility of recycling locally-discharged groundwater back to the aquifer, the groundwater was discharged far from the wellhead. As shown on Photograph 16, the blue-colored discharge hose was run 350 feet east from the wellhead to the concrete-lined portion of the channeled, east-flowing Las Vegas Wash tributary that runs parallel to the Test Site.

Description of the Calibration Test - Following installation of the pump on the morning of September 14, and after pump surge development had been completed, the pump was run at a constant rate to determine a rate the well could sustain for a 48-hour period. With the ball valve fully open, the pump produced 50 gallons per minute (gpm) with less than three feet of drawdown. The valve was closed slightly until the flow meter read a

constant pumping rate of 45gpm. The 48-hour pumping test of well PC-70 was thus performed at a constant rate of 45 gallons per minute.

Description of the Test - The constant discharge pumping portion of the PC-70 aquifer test was conducted for a total of 48 hours commencing at 1500 hours (3pm) on September 14, 1998. The pumping rate was maintained at a constant 45 gallons per minute. The discharged groundwater was clear (see Photograph 17).

As shown on Figure 2, drawdown was established in all three of the observation wells soon after pumping started. Review of Figure 2 shows that the shape of the drawdown cone remained the same throughout the length of the 48-hour pumping test, the only change being the increasing drawdown as more water was removed from the aquifer. A total of nearly 130,000 gallons of groundwater were pumped from the aquifer during the 48-hour pumping test.

The recovery portion of the PC-70 aquifer test commenced with the termination of pumping at 1500 hours (3pm) on September 16, 1998. After an initial rapid rise in water level, recovery was slow during the 21-hour recovery test. A notable increase in the rate of recovery near the end of the test showed the possible arrival of the recharge front resulting from the September 11 storm event.

Tabulations and graphs of drawdown and recovery data for Test Well PC-70 are included in Addendum D. From a starting water level of 18.73 feet, drawdown was 2.36

feet to a pumping level of 21.09 feet. The specific capacity in Test Well PC-70 was 19 gallon per minute per foot of drawdown at the end of the 48-hour pumping test.

Tabulations and graphs of drawdown and recovery data for Observation Well PC-17 are included in Addendum E. From a starting water level of 18.1 feet, drawdown was 0.63 feet to a depth of 18.73 feet.

Tabulations and graphs of drawdown and recovery data for Observation Well PC-18 are included in Addendum F. From a starting water level of 19.42 feet, drawdown was 0.42 feet to a depth of 19.84 feet.

Tabulations and graphs of drawdown and recovery data for Observation Well PC-55 are included in Addendum G. From a starting water level of 17.87 feet, drawdown was 0.36 feet to a depth of 18.23 feet.

ANALYSES OF PC-70 AQUIFER TEST DATA

Data gathered during the constant discharge pumping and recovery tests of Test Well PC-70 were analyzed using the Theis log-log type curve matching, the Boulton log-log delayed drainage curve matching, and the Jacobs semi-log straight line methodologies (Davis and DeWiest, 1966; Johnson UOP, 1975; Lohman, 1972). Analyses of the test data are provided in Addendums D, E, F, G, and H. Analytical results are summarized in Table 3 below.

TABLE 3
COMPILATION OF HENDERSON PC-70 TEST DATA
 Date of Test: September 14-17, 1998

Well No.	Test Phase	Analysis	Transmissivity (gpd/ft)	Permeability (gpd/ft ²)	Hydraulic Conductivity (ft/day)	Storage Coefficient
PC-70 Saturated Interval = 32 ft	Drawdown Recovery	Jacobs (Semi-Log) Time vs Drawdown	49500	1547	207	
		Jacobs (Semi-Log) t/t' vs Drawdown	69882	2184	292	
PC-17 Saturated Interval = 33 ft	Drawdown	Jacobs (Semi-Log) Time vs Drawdown	49500	1500	201	0.08
	Drawdown	Theis (Log-Log) Type Curve Match	56048	1698	227	0.03
	Drawdown	Boulton (Log-Log) Delayed Drainage	46877	1421	190	0.04
	Recovery	Jacobs (Semi-Log) t/t' vs Residual Drawdown	79200	2400	321	
PC-18 Saturated Interval = 33 ft	Drawdown	Jacobs (Semi-Log) Time vs Drawdown	40966	1241	166	0.03
	Drawdown	Theis (Log-Log) Type Curve Match	54282	1645	220	0.08
	Drawdown	Boulton (Log-Log) Delayed Drainage	53714	1628	218	0.09
	Recovery	Jacobs (Semi-Log) t/t' vs Residual Drawdown	108000	3273	438	
PC-55 Saturated Interval = 37 ft	Drawdown	Jacobs (Semi-Log) Time vs Drawdown	66000	1748	239	0.11
	Drawdown	Theis (Log-Log) Type Curve Match	46877	1267	169	0.03
	Drawdown	Boulton (Log-Log) Delayed Drainage	39666	1072	143	0.04
	Recovery	Jacobs (Semi-Log) t/t' vs Residual Drawdown	132000	3568	477	
Distance-Drawdown Graphs for Test Average Saturated Interval = 34 ft	Drawdown	Distance-Drawdown at 100 minutes	51652	1519	203	0.04
	Drawdown	Distance-Drawdown at 720 minutes	49500	1456	195	0.08
	Drawdown	Distance-Drawdown at 1440 minutes	48490	1426	191	0.10
	Drawdown	Distance-Drawdown at 2160 minutes	51652	1519	203	0.08
	Drawdown	Distance-Drawdown at 2880 minutes	51652	1519	203	0.06

The effects of casing storage during the early part of the test were taken into account during the analyses of these test data. Given the approximately 50 gallons of water residing in the 6-inch (ID) casing and screen in Test Well PC-70, at a pumping rate of 45 gallons per minute the effects of casing storage would be eliminated in less than two minutes. After that time, casing storage became negligible.

Calculations of Aquifer Coefficients

As noted above, data gathered during the constant discharge pumping and recovery tests of Test Well PC-70 were analyzed using the Theis type curve, the Boulton delayed drainage, and the Jacobs methodologies. These methodologies were used to calculate the transmissivity and storage coefficient of the channel-fill alluvial aquifer at the respective well sites. From the transmissivity data permeabilities and hydraulic conductivities of the alluvial aquifer were calculated. It should be noted that, for permeability calculations, Test Well PC-70 and the three observation wells all fully penetrated the entire saturated thickness of the channel-fill alluvium.

Calculations of aquifer coefficients for Test Well PC-70 and Observation Wells PC-17, PC-18, and PC-55 are presented on their respective data plots and on separate tabulations presented in Addendums D, E, F, and G, respectively. The data set for Test Well PC-70 includes tabulations of drawdown and recovery data, an arithmetic plot of drawdown and recovery data, a Jacobs (semi-log) plot of time versus drawdown data, and a Jacobs (semi-log) plot of t/t' (recovery) versus drawdown data. The respective data sets for the three observation wells include tabulations of drawdown and recovery data, an arithmetic plot of drawdown and recovery data, a Jacobs (semi-log) plot of time versus drawdown data, a Theis (log-log) type curve match plot, a Boulton (log-log) delayed drainage type curve match plot, and a Jacobs (semi-log) plot of t/t' (recovery) versus drawdown data.

Jacobs Modified Semi-Log Straight-Line Analyses of Drawdown Data - As shown in Table 3 above, transmissivities calculated from the Jacobs (semi-log) straight-line analyses of the time versus drawdown data for Test Well PC-70 and the three observation wells range from 40,966 gallons per day per foot (gpd/ft) to 66,000 gpd/ft, averaging 51,492 gpd/ft. Corresponding permeabilities range from 1,241 gallons per day per square foot (gpd/ft²) to 1,547 gpd/ft², averaging 1,509 gpd/ft². Storage coefficients range from 0.03 to 0.11, averaging 0.07.

Theis Log-Log Type Curve Match Analyses of Drawdown Data - Review of the log-log plots of time versus drawdown data for Observation Wells PC-17 and PC-18 show very good matches with the Theis Type Curve (Lohman Plate 9, 1972) after about the first 100 minutes of the pumping test. The log-log plot of time versus drawdown data for Observation Well PC-55 shows a very good match with the Theis Type Curve after about the first 300 minutes of the pumping test.

As shown in Table 3 above, transmissivities calculated from the Theis (log-log) curve-matching analyses of the time versus drawdown data for the three observation wells range from 46,877 gpd/ft to 56,048 gpd/ft, averaging 52,402 gpd/ft. Corresponding permeabilities range from 1,267 gpd/ft² to 1,698 gpd/ft², averaging 1,537 gpd/ft². Storage coefficients range from 0.03 to 0.08, averaging 0.05.

Boulton Log-Log Delayed Drainage Curve Match Analyses of Drawdown Data - Review of the log-log plots of time versus drawdown data for the three observation wells show

good matches with diversions of the early-time data plots from the Theis Type Curve (Lohman Plate 8, 1972) due to the effects of delayed drainage from storage in the unconfined alluvial aquifer. As shown in Table 3 above, transmissivities calculated from the Boulton delayed drainage curve-matching analyses of the time versus drawdown data for the three observation wells range from 39,666 gpd/ft to 53,714 gpd/ft, averaging 46,752 gpd/ft. Corresponding permeabilities range from 1,072 gpd/ft² to 1,628 gpd/ft², averaging 1,374 gpd/ft². Storage coefficients range from 0.04 to 0.09, averaging 0.06.

Jacobs Semi-Log Straight-Line Analyses of Recovery Data - Review of the semi-log plots of t/t' versus residual drawdown recovery data show the effects of both a limited aquifer and unusual recharge derived from the September 11, 1998 storm event. Initial straight-line trends of the t/t' versus residual drawdown plots do not go through the origin, indicating a limited aquifer. The slow recovery of the water levels in Test Well PC-70 and the three observation wells suggest some dewatering of the channel-fill alluvial aquifer.

The upward trend of the late t/t' versus residual drawdown data, however, show the effects of a recharge event. This is believed to reflect the arrival of the recharge front resulting from the flooding in the area during the September 11, 1998 storm event.

Transmissivities calculated from the Jacobs (semi-log) straight-line analyses of the t/t' versus residual drawdown recovery data for Test Well PC-70 and the three observation wells are shown in Table 3 above. However, due to the effects of storm event-related

recharge, these data are not considered accurate and reliable and are not used in this report to represent the channel-fill alluvial aquifer.

Jacobs Semi-Log Straight-Line Analyses of Distance-Drawdown Data - While semi-log plots of time-distance data show the lowering of the water level at any time within the cone of depression, semi-log plots of distance-drawdown data show the shape and position of the cone of depression at any given time (Johnson UOP, 1975). These diagrams can be used to calculate transmissivity and storage coefficient.

Semi-log plots of distance-drawdown data were generated for time periods 100 minutes, 720 minutes (12 hours), 1,440 minutes (24 hours), 2,160 minutes (36 hours), and 2,880 minutes (48 hours) into the pumping test. As shown in Table 3 above, transmissivities calculated from these analyses are very consistent, ranging from 48,490 gpd/ft to 51,652 gpd/ft, averaging 50,598 gpd/ft. Corresponding permeabilities range from 1,398 gpd/ft² to 1,519 gpd/ft², averaging 1,488 gpd/ft². Storage coefficients range from 0.04 to 0.10, averaging 0.07. Calculations of aquifer coefficients for the five distance-drawdown analyses are presented on their respective data plots and tabulations presented in Addendum H.

Estimation of Test Well Efficiency from Distance-Drawdown Data

The efficiency of Test Well PC-70 can be estimated by comparing the theoretical drawdown calculated for the pumping well to the actual drawdown on a plot of distance-drawdown data (Johnson UOP, 1975). This is done by extending the straight distance-

drawdown line to a point where it intercepts the radius of the pumping well on the horizontal scale.

The resulting projection of well efficiency is presented in Addendum I. Comparing a theoretical drawdown of 1.95 feet to the actual drawdown of 2.36 feet after 48 hours of pumping yields a projected well efficiency of 83%.

CONCLUSIONS

This investigation, which was centered around the construction and testing of Test Well PC-70, was performed to better quantify the hydrogeologic characteristics of the channel-fill alluvial aquifer at the Pittman Lateral. Since PC-70 was to be a groundwater production well rather than a monitor well, every effort was made in the design, construction, and development of the well to make it as efficient as possible. Review of the data resulting from the Pittman Lateral Aquifer Test suggests that the goal of an efficient well was met.

The channel-fill alluvium at the Pittman Lateral Test Site was found to consist of an alternating sequence of light-brown, fine-grained sand and fine- to coarse-grained sand and gravel. No significant quantities of clay were found in the alluvial sediments. The top of the Muddy Creek Formation, which was encountered at a depth of about 49 feet, was found to consist of a gravelly clay.

An aquifer test consisting of a 48-hour constant discharge pumping test followed by 21 hours of recovery was performed at the Pittman Lateral Test Site. The testing program included the pumping of Test Well PC-70 at a constant rate of 45 gallons per minute and the monitoring of water levels in it and three observation wells, PC-17, PC-18, and PC-55.

Drawdown and recovery data resulting from the aquifer test were analyzed using the Jacobs semi-log straight-line, the Theis log-log curve matching, the Boulton log-log delayed drainage curve matching, and the Jacobs semi-log distance-drawdown analysis methodologies. Comparison of aquifer coefficients resulting from the analyses of drawdown data from the show excellent consistency. Due to the effects of storm event-related recharge, recovery data are not considered accurate and reliable and were not used in this report to represent the channel-fill alluvial aquifer.

Based upon the results of the Pittman Lateral Aquifer Test, it can be concluded that the transmissivity of the channel-fill alluvium at the test site ranges from 39,666 gpd/ft to 66,000 gpd/ft, averaging 50,425 gpd/ft. Likewise, it can be concluded that corresponding permeabilities range from 1,072 gpd/ft² to 1,698 gpd/ft², averaging 1,393 gpd/ft². These values are consistent with sand and gravels containing fine sands and silts.

Storage coefficients were found to range from 0.03 to 0.11, averaging 0.06, which is consistent with an unconfined aquifer under water-table conditions. A storage coefficient of 0.06 in an unconfined aquifer translates to a specific yield of 6%.

REFERENCES CITED

Davis, S.N., and R.J.M. DeWiest, 1966, Hydrogeology: John Wiley and Sons, Inc., New York, 463 p.

Johnson, UOP, 1975, Ground Water and Wells: Johnson Division UOP, Inc., 440p.

Kerr-McGee Chemical LLC, 1998, Phase II Groundwater Perchlorate Investigation Report:: Document, 21 pages.

Lohman, S. W., 1972, Ground-Water Hydraulics: U.S. Geological Survey Professional Paper 708, 70p.

FIGURES



FIGURES

FIGURE 1
GRAIN-SIZE GRADATION CURVES FOR TEST BORING SEDIMENT SAMPLES
PITTMAN LATERAL TEST WELL PC-70
Date Samples Collected: September 8, 1998

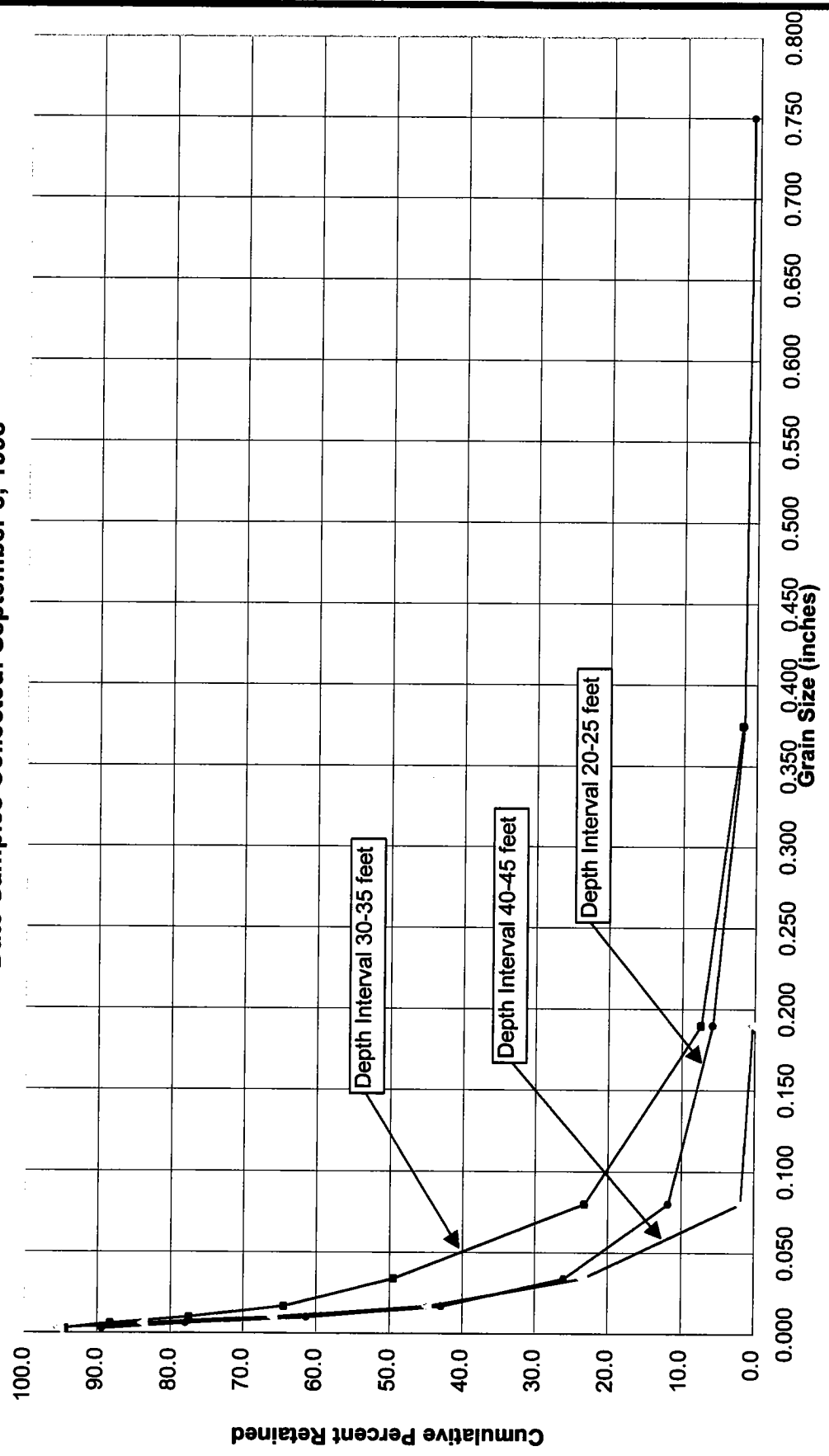
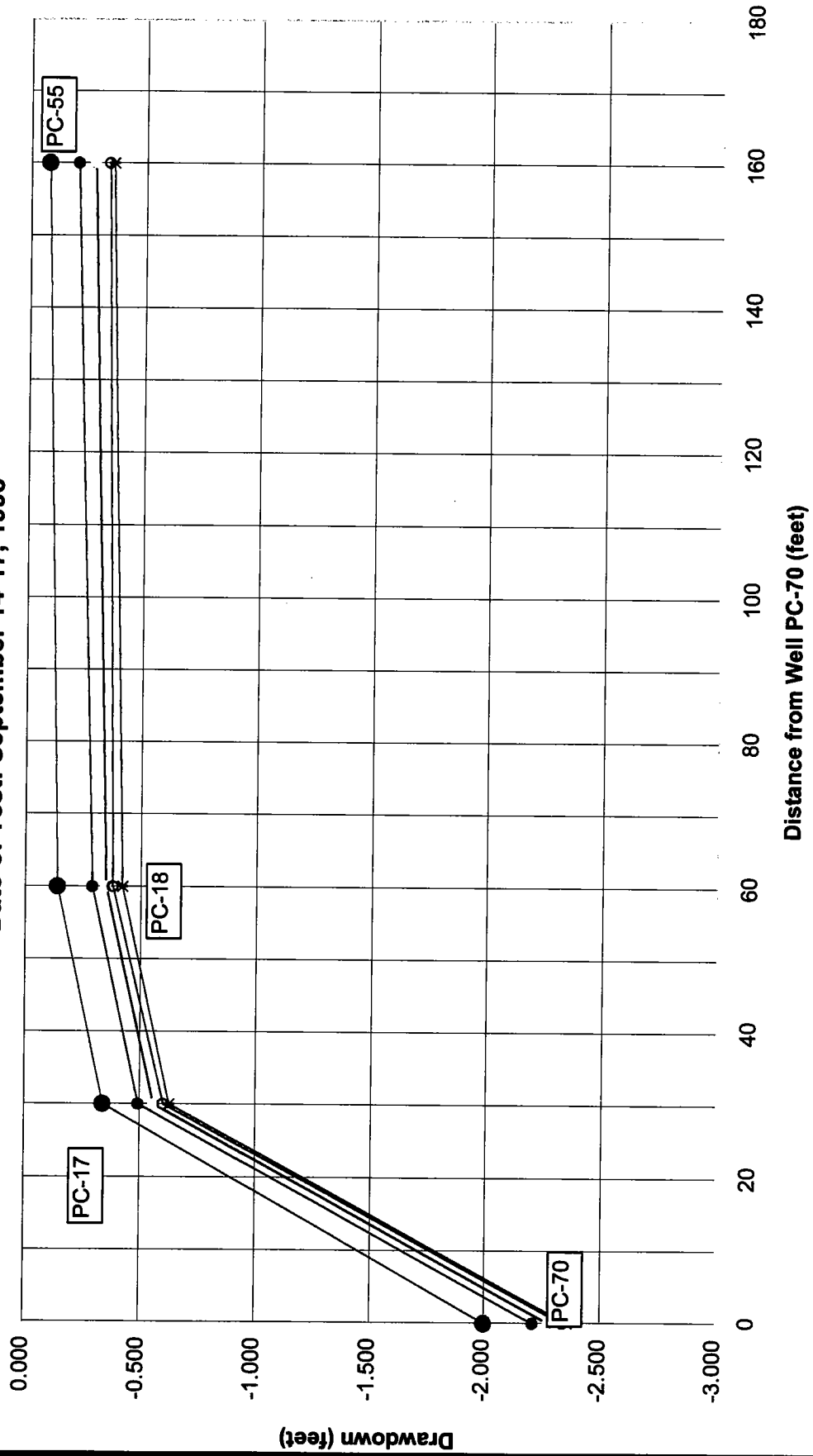

FIGURE 2
GROWTH OF THE DRAWDOWN CONE
AT 100, 720, 1440, 2160, AND 2880 MINUTES
CONSTANT DISCHARGE TEST OF PITTMAN LATERAL TEST WELL PC-70
Date of Test: September 14-17, 1998



PHOTOGRAPHS

DAMES & MOORE

ADDENDUM B

**Dames and Moore Report on PC-70 Test Boring
Grain-Size Analyses**



RECEIVED

SEP 15 1998

HYDROLOGY

7115 Amigo Street, Suite 110
Las Vegas, Nevada 89119
702 837 1500 Tel
702 837 1600 Fax

September 10, 1998

Compliance Drilling Corporation
P.O. Box 94136
Las Vegas, NV 89193

Attention: Mr. Brian Johnson

**Subject: Soil Physical Testing and Well Design Assistance
Proposed Monitoring Well,
Kerr-McGee Chemical Corporation, Henderson, Nevada**

Dear Mr. Johnson:

Dames & Moore (D&M) is pleased to provide Compliance Drilling Corporation (Compliance) with this summary of our soil testing and well design recommendations for a proposed groundwater monitoring at Kerr-McGee Chemical Corporation (KMCC). It is our understanding that the proposed well will be 6-inch diameter PVC, have a total depth of about 60 feet below ground surface (bgs), and be screened from slightly above the water table (about 15 feet bgs) to the total depth of the boring. A pilot hole was first drilled in order to log the lithology and to collect soil samples for physical testing.

Four bulk soil samples and a soil boring log were delivered to the D&M Las Vegas office on September 8, 1998. The samples were collected from the intervals of 15-17, 20-25, 30-35, and 40-45 feet bgs. The samples were shipped overnight to D&M's Salt Lake City soils laboratory for grain size analysis. Results of the grain size tests (attached) indicate the soils consist primarily of well graded sands with minor amounts of gravel and fines.

Calculations to determine the optimum screen size and filter pack were performed on the lower three samples. The uppermost sample, 15-17 feet bgs, was not considered because those soils are above the water table according to the boring log. Grain size tests indicate the lower two samples from 30-35 and 40-45 feet bgs are nearly identical, while the sample from 20-25 feet bgs is slightly finer grained. Accordingly, the 20-25 foot sample was determined to be the guiding sample in the screen and filter pack selection.

Compliance Drilling
Kerr-McGee Chemical Corporation
September 10, 1998
Page 2

Based on the grain size tests and calculations, we recommend a 0.020-inch screen size and a Monterey number 2/12 filter pack or equivalent. We further recommend using a "v"-shaped, continuous wire screen, which should allow for a more thorough development and enhance water yield from the well.

If you have any questions or require additional assistance, please do not hesitate to call.

Sincerely,
DAMES & MOORE



Mark H. Allen, R.G., C.E.M.
Project Geologist

Attachments: Grain Size Test Results with calculations

cc: Mr. Mark Porterfield, KMCC, via fax, (702) 651-2310
Mr. Steve Lower, KMCC, via fax, (405) 270-4244

Lone Star Sand Curves

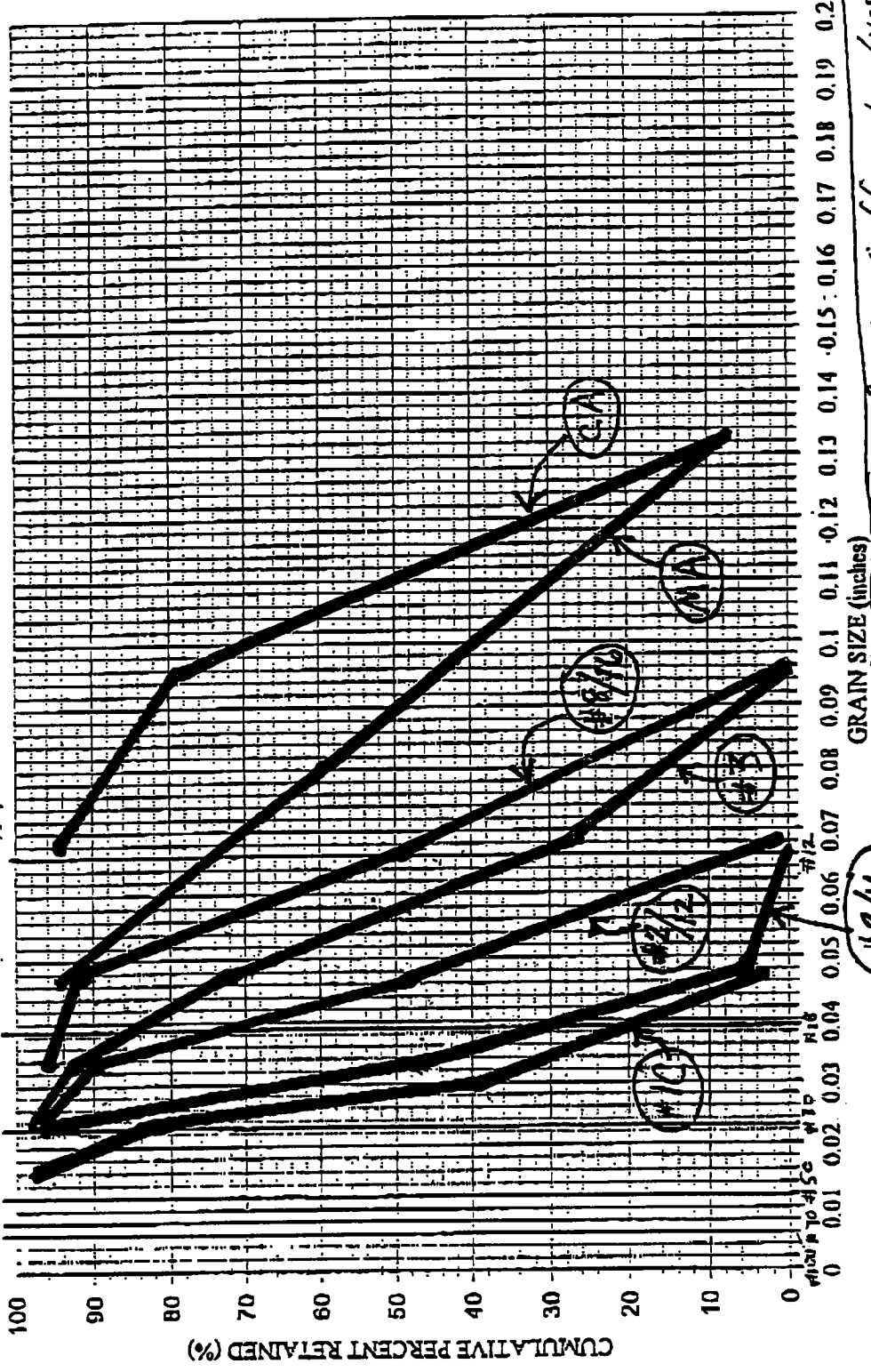

	Uniformity Coefficients ($\frac{u_0}{u_{90}}$)	
# 1C	1.6	
# 2/16	1.5	# 8/16
# 2/12	1.6	MA
# 3	1.8	CA
		1.5
		1.9
		1.5

GRADATION CURVE

Sample KM 20-25

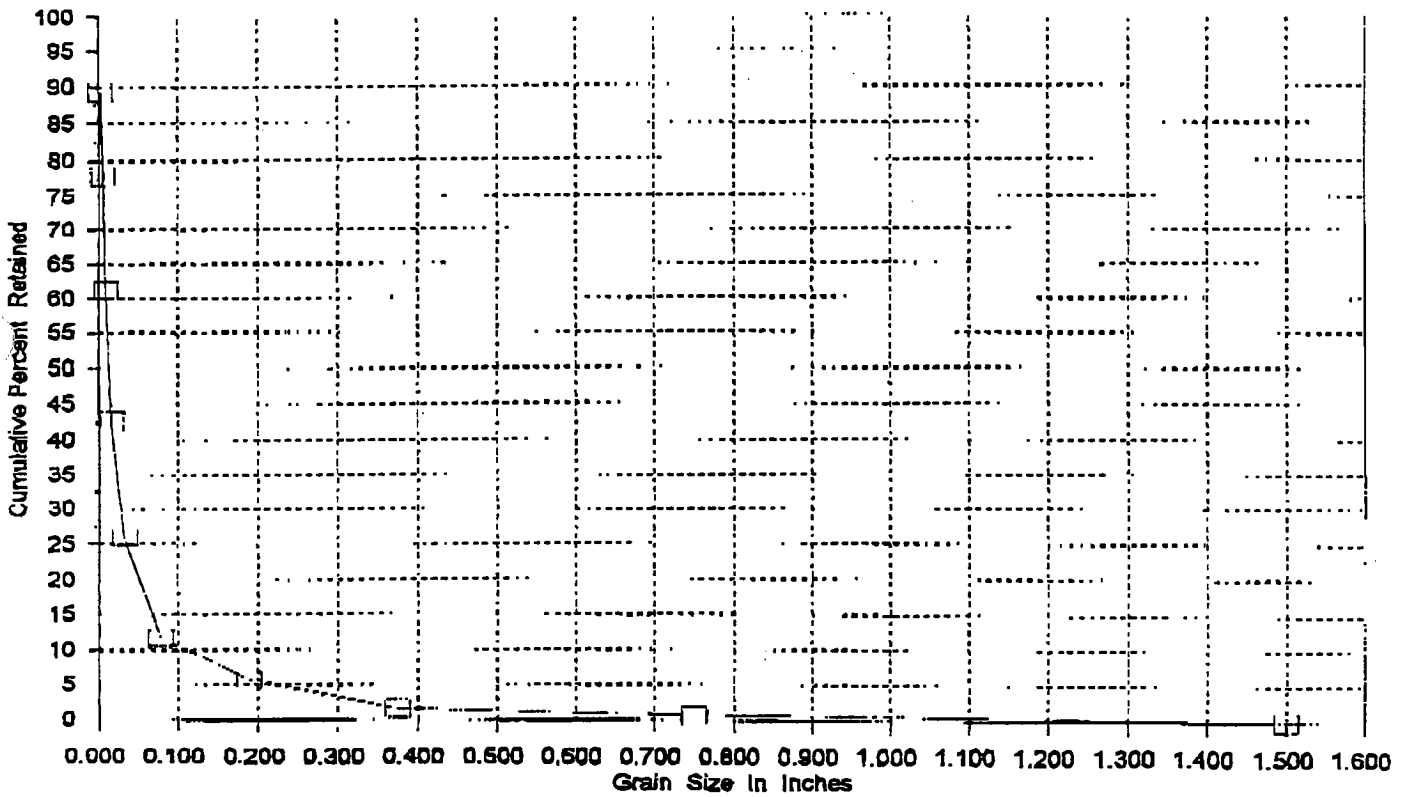

Kerr McGee Chemical
Henderson NV

Wt soil and dish 88.07
Dry soil & dish 83.39
Dish 43.51

Sample KM 20-25

#4 Total for sieve 160.1

Moisture Content - 11.7
4 material

SIEVE ANALYSIS

as received 1458.5 g
Total sample dry 1305.32 g
Weight of sample split # 4 143.285 g

Sieve #	weight		% retained	mm	inches
	retained	finer			
6.0 inch	0	*****	0.0	152	6
4.0 inch	0	*****	0.0	100	4
3.0 inch	0	*****	0.0	75.0	3
1.5 inch	0	*****	0.0	37.5	1.5
3/4 inch	10.35	99.21%	0.8	19.0	0.75
3/8 inch	22.24	98.30%	1.7	9.5	0.375
# 4	75.08	94.25%	5.8	4.8	0.1895
# 10	9.19	88.20%	11.8	2.0	0.07896
# 20	30.78	74.00%	26.0	0.85	0.03356
# 40	56.47	57.10%	42.9	0.43	0.01698
# 60	84.38	38.75%	61.3	0.25	0.00987
# 100	109.76	22.05%	77.9	0.15	0.00592
# 200	127.16	10.61%	89.4	0.075	0.00296

Missing 10.6%

90% Ret
0.003

40% Ret
0.016

UC
5.3

70% Ret
0.005

Factor
7

70% x Factor
0.035

8

0.04 ✓

#2/12

9

0.045

0.02 slot

GRADATION CURVE

Sample KM 30-35

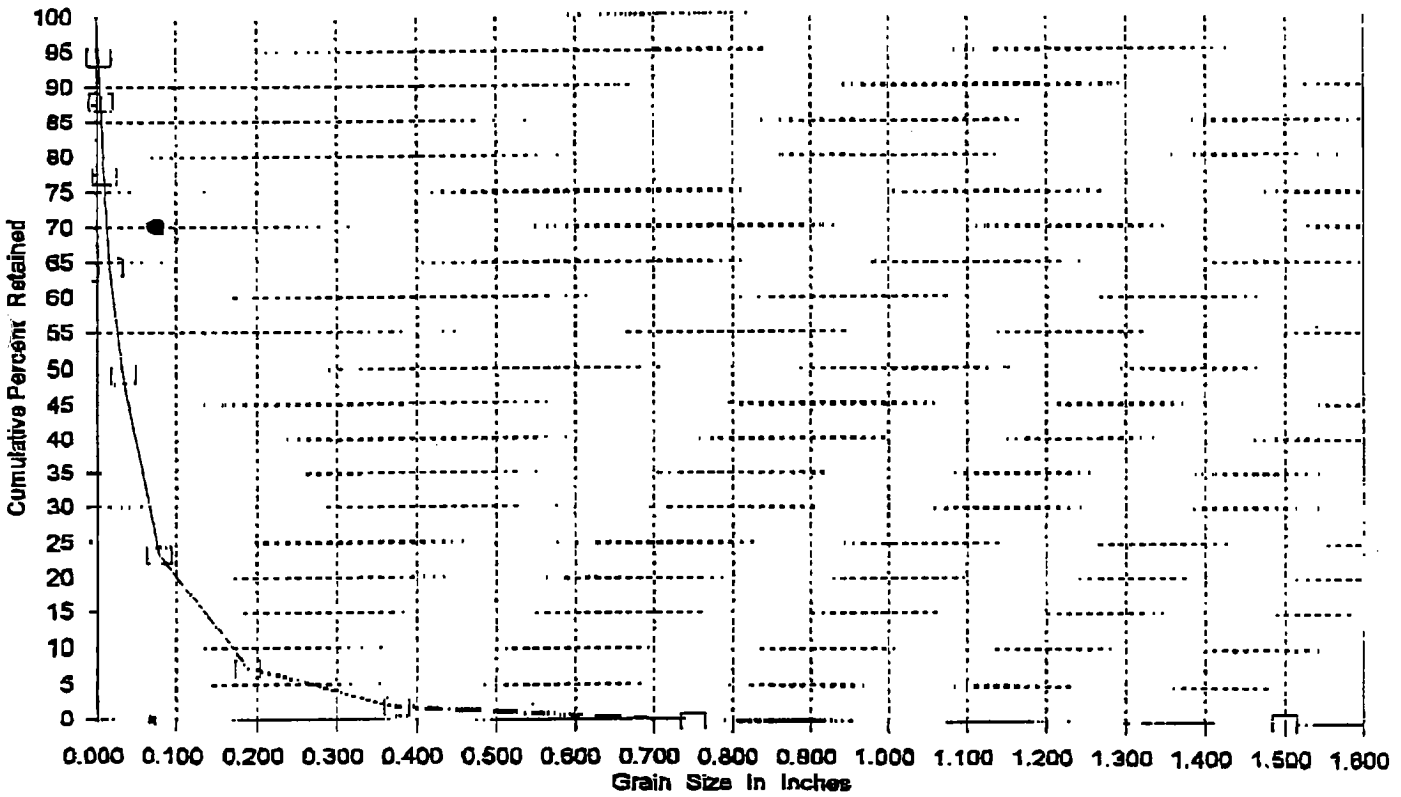

<u>90% Ret</u>	<u>40% Ret</u>	<u>UC</u>	<u>70% Ret</u>	<u>Factor</u>	<u>70% Ret</u>
0.0028	0.027	9.7	0.01	7	<u>< factor</u>
				8	0.07
				9	0.08 ✓
					0.09

MA Lonestar w/ 0.05 slot size, but using finer #2/12 w/ 0.02 slot should be fine

Sep-09-98 05:16P DAMES & MOORE SOILS LAB

801 521 5013

P.04

Kerr McGee Chemical	Wt soil and dish	84.37
Henderson NV	Dry soil & dish	80.5
	Dish	43.79
Sample KM 30-35		
	-#4 Total for sieve	172.2

Moisture Content = 10.5
 -# 4 material

SIEVE ANALYSIS

as received 1376.8 g
 Total sample dry 1245.5 g
 Weight of sample split # 4 155.778 g

Sieve #	weight		% retained	mm	inches
	retained	finer			
6.0 inch	0	*****	0.0	152	6
4.0 inch	0	*****	0.0	100	4
3.0 inch	0	*****	0.0	75.0	3
1.5 inch	0	*****	0.0	37.5	1.5
3/4 inch	0	*****	0.0	19.0	0.75
3/8 inch	23.94	98.08%	1.9	9.5	0.375
# 4	91.84	92.63%	7.4	4.8	0.1895
# 10	26.7	76.75%	23.2	2.0	0.07896
# 20	70.68	50.60%	49.4	0.85	0.03356
# 40	95.87	35.62%	64.4	0.43	0.01698
# 60	117.72	22.63%	77.4	0.25	0.00987
# 100	135.87	11.84%	88.2	0.15	0.00592
# 200	146.28	5.65%	94.4	0.075	0.00296

Kerr McGee Chemical	Wt soil and dish	108.62
Henderson NV	Dry soil & dish	99.17
	Dish	43.34
Sample KM 40-45		
	-#4 Total for sieve	219.7

Moisture Content = 16.9
 -# 4 material

SIEVE ANALYSIS

as received 1359.9 g
 Total sample dry 1163.04 g
 Weight of sample split # 4 187.896 g

Sieve #	weight retained	finer	% retained	mm	inches
6.0 inch	0	*****	0.0	152	6
4.0 inch	0	*****	0.0	100	4
3.0 inch	0	*****	0.0	75.0	3
1.5 inch	0	*****	0.0	37.5	1.5
3/4 inch	0	*****	0.0	19.0	0.75
3/8 inch	0	*****	0.0	9.5	0.375
# 4	3.19	99.73%	0.3	4.8	0.1895
# 10	3.09	98.09%	1.9	2.0	0.07896
# 20	43.8	76.48%	23.5	0.85	0.03356
# 40	83.97	55.16%	44.8	0.43	0.01698
# 60	123.76	34.04%	66.0	0.25	0.00987
# 100	157.45	16.16%	83.8	0.15	0.00592
# 200	178.99	4.73%	95.3	0.075	0.00296

<u>90% Ret</u>	<u>40% Ret</u>	<u>UC</u>	<u>70% Ret</u>	<u>Factor</u>	<u>70% x</u>
0.003	0.019	6.3	0.009	7	<u>Factor</u>
				8	0.063
				9	0.072
					0.081

8/6 Lonestar w/ 0.05 slot, but # 2/12 sand is 0.02 slot should be fine

GRADATION CURVE

Sample KM 40-45

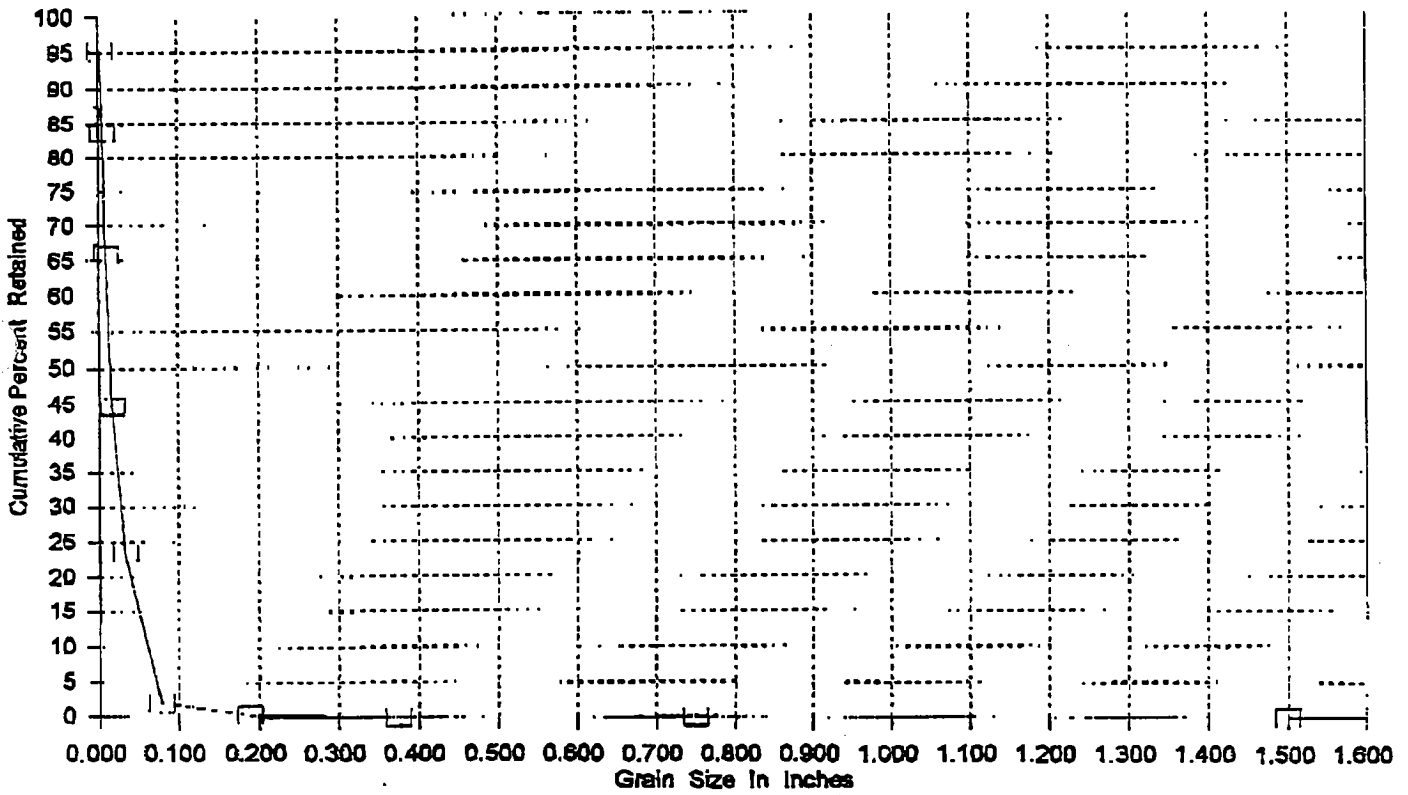

WELL DIAGRAMS

ADDENDUM C

**Well Construction Diagrams for Test Well PC-70
and Observation Wells PC-17, PC-18, and PC-55**

**KERR-McGEE CORPORATION
HYDROLOGY DEPARTMENT
MONITORING WELL INSTALLATION DIAGRAM**

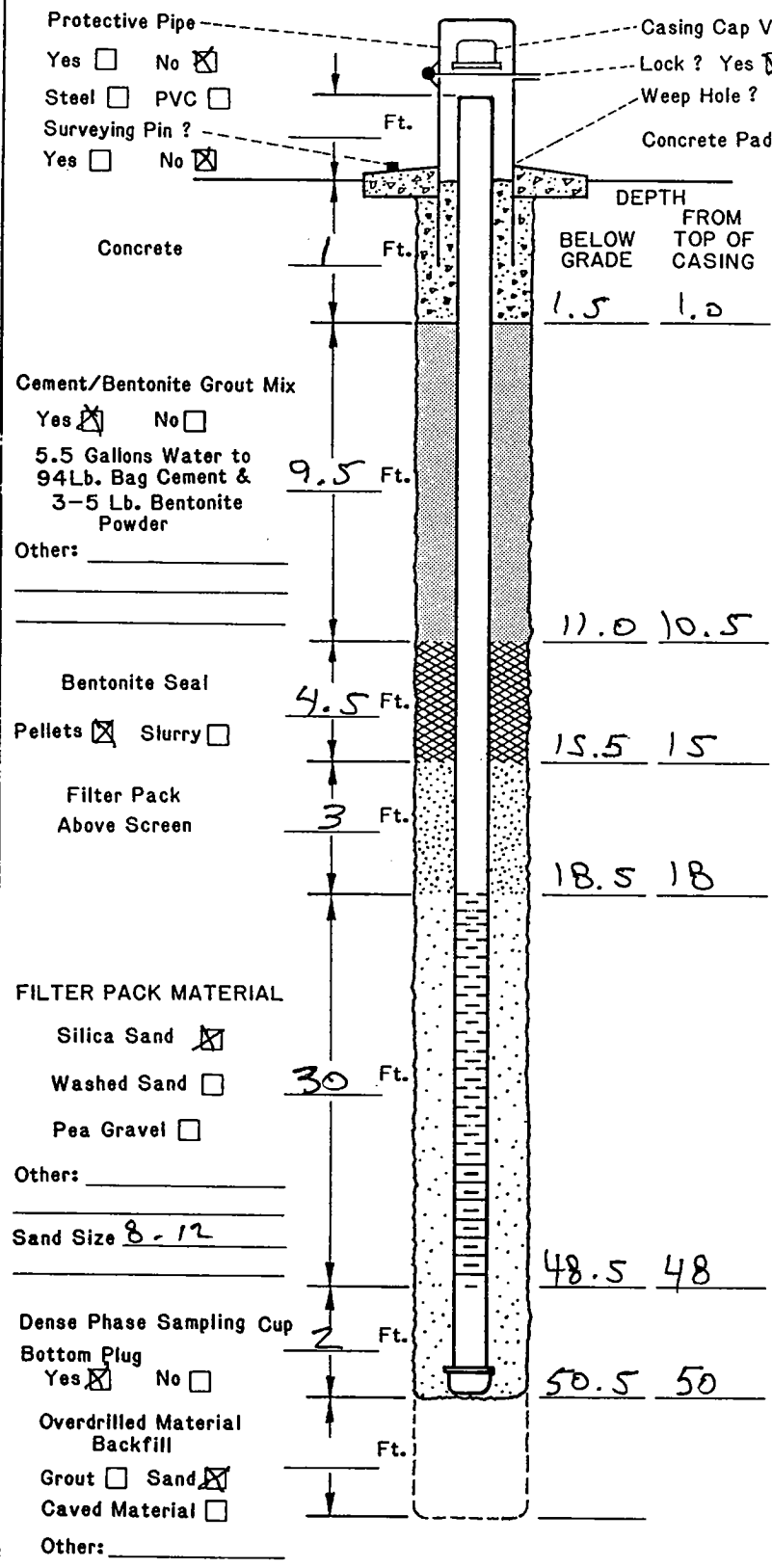

- DRILLING INFORMATION:**
- Borehole Diameter = 1.2 Inches.
 - Were Drilling Additives Used? Yes No
 Revert Bentonite Water
 Solid Auger Hollow Stem Auger
 - Was Outer Steel Casing Used? Yes No
 Depth = _____ to _____ Feet.
 - Borehole Diameter for Outer Casing _____ Inches.

- WELL CONSTRUCTION INFORMATION:**
- Type of Casing: PVC Galvanized Teflon
 Stainless Other _____
 - Type of Casing Joints: Screw-Couple Glue-Couple Other _____
 - Type of Well Screen: PVC Galvanized
 Stainless Teflon Other Wire-wrap PVC
 - Diameter of Casing and Well Screens:
 Casing 6 Inches, Screen 6 Inches.
 - Slot Size of Screens: 0.020
 - Type of Screen Perforation: Factory Slotted
 Hacksaw Drilled Other Wire-wrapped
 - Installed Protector Pipe w/Lock: Yes No

- WELL DEVELOPMENT INFORMATION:**
- How was Well Developed? Bailing Pumping
 Air Surfing (Air or Nitrogen) Other Surging
 - Time Spent on Well Development? _____
1 2 Minutes/Hours
 - Approximate Water Volume Removed? 1500 Gallons
 - Water Clarity Before Development? Clear
 Turbid Opaque
 - Water Clarity After Development? Clear
 Turbid Opaque
 - Did Water have Odor? Yes No
 If Yes, Describe _____
 - Did Water have any Color? Yes No
 If Yes, Describe _____

WATER LEVEL INFORMATION:
 Water Level Summary (From Top of Casing)
 During Drilling 17 Ft. Date 9-8-98
 Before Development 19.44 Ft. Date 9-12-98
 After Development 18.73 Ft. Date 9-14-98

Driller/Firm Compliance Drillings Drill Rig Type Mobile Date Installed 9-12-98
 Drill Crew _____ Well No. PC-70 Kerr-McGee Hydrologist Steven R. Lower

FLUSHMOUNT
WELL

KERR-McGEE CORPORATION
HYDROLOGY DEPARTMENT
MONITORING WELL INSTALLATION DIAGRAM

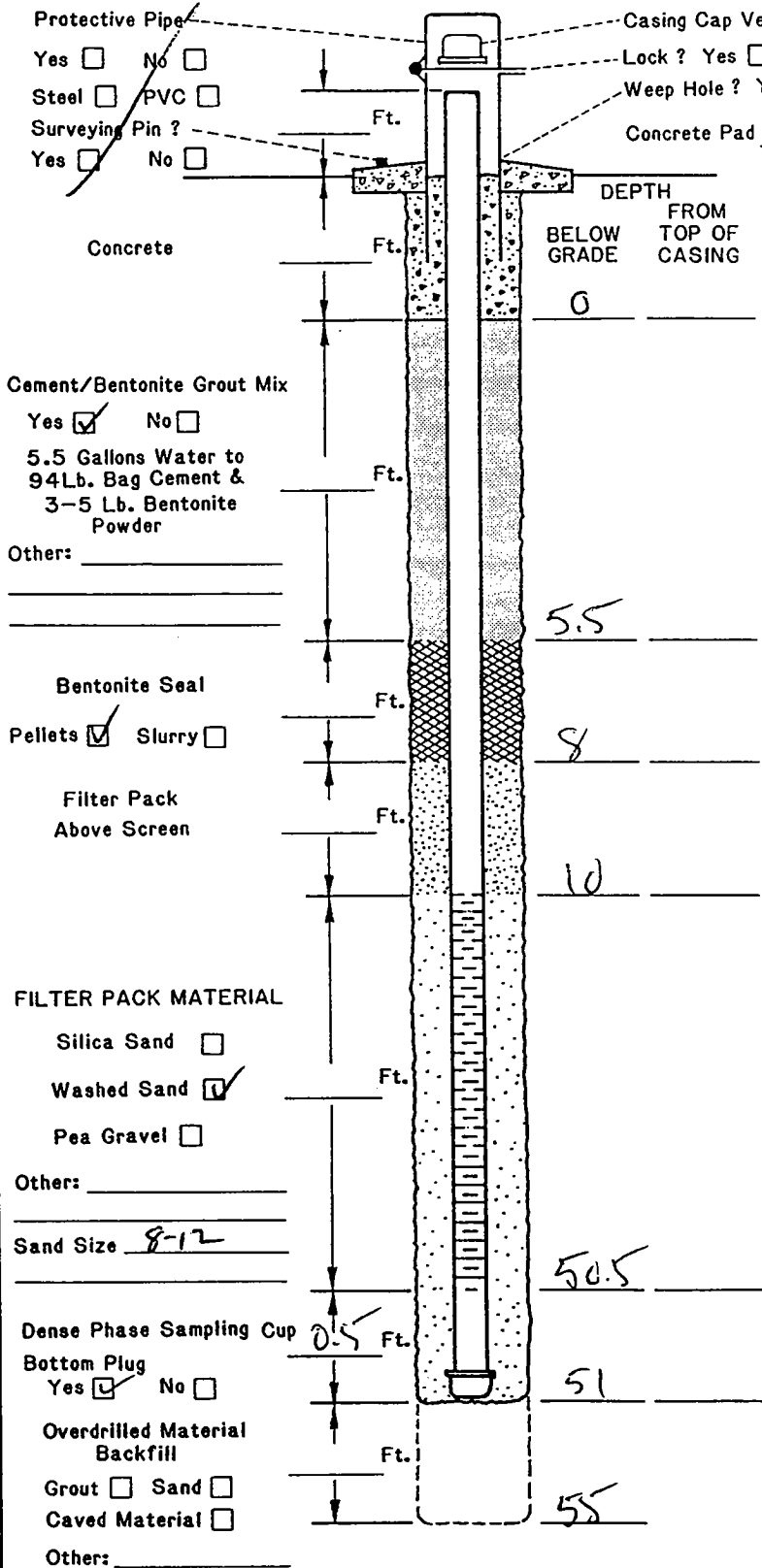

- DRILLING INFORMATION:**
- Borehole Diameter= _____ Inches.
 - Were Drilling Additives Used? Yes No
Revert Bentonite Water
Solid Auger Hollow Stem Auger
 - Was Outer Steel Casing Used? Yes No
Depth= _____ to _____ Feet.
 - Borehole Diameter for Outer Casing _____ Inches.
- WELL CONSTRUCTION INFORMATION:**
- Type of Casing: PVC Galvanized Teflon
Stainless Other _____
 - Type of Casing Joints: Screw-Couple Glue-Couple Other _____
 - Type of Well Screen: PVC Galvanized
Stainless Teflon Other _____
 - Diameter of Casing and Well Screens:
Casing 2 Inches, Screen 2 Inches.
 - Slot Size of Screens: 010
 - Type of Screen Perforation: Factory Slotted
Hacksaw Drilled Other _____
 - Installed Protector Pipe w/Lock: Yes No
- WELL DEVELOPMENT INFORMATION:**
- How was Well Developed? Bailing Pumping
Air Surging (Air or Nitrogen) Other _____
 - Time Spent on Well Development? _____ Minutes/Hours
 - Approximate Water Volume Removed? 110 Gallons
 - Water Clarity Before Development? Clear
Turbid Opaque
 - Water Clarity After Development? Clear
Turbid Opaque
 - Did Water have Odor? Yes No
If Yes, Describe _____
 - Did Water have any Color? Yes No
If Yes, Describe _____
- WATER LEVEL INFORMATION:**
Water Level Summary (From Top of Casing)
- During Drilling 19' Ft. Date 4/1/98
Before Development 19.2' Ft. Date 4/17/98
After Development 19.2' Ft. Date 4/17/98

Driller/Firm WEBER Drill Rig Type Mobile 61 Date Installed 4/8/98
Drill Crew LEE ROBERTSON Well No. PC-17 Kerr-McGee Hydrologist Jim Crawford

FLUSH
MOUNT

KERR-McGEE CORPORATION
HYDROLOGY DEPARTMENT
MONITORING WELL INSTALLATION DIAGRAM

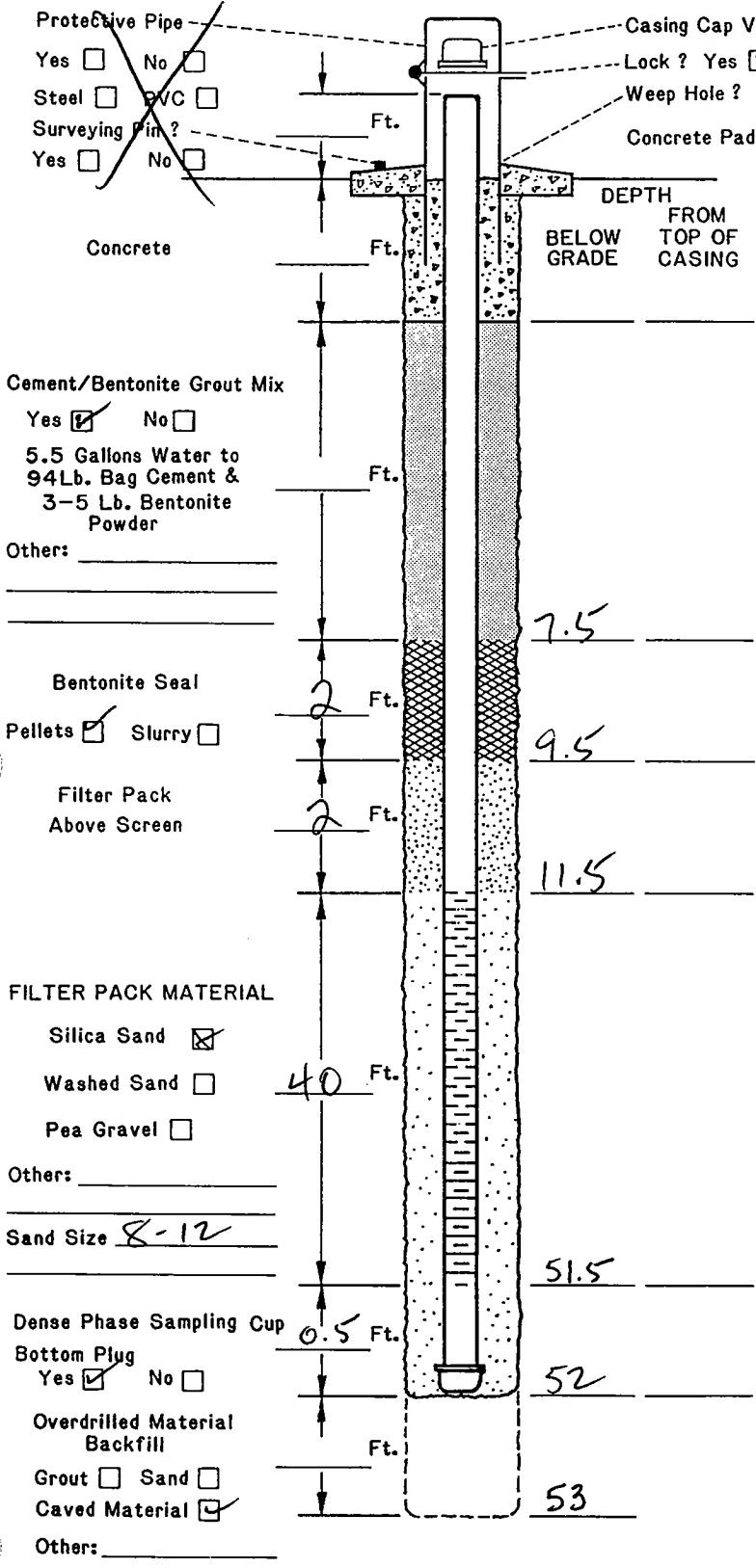

Casing Cap Vent? Yes No
Lock? Yes No
Weep Hole? Yes No

Concrete Pad _____ Ft. x _____ Ft. x _____ Inches

DRILLING INFORMATION:

- Borehole Diameter = 8 Inches.
- Were Drilling Additives Used? Yes No
Revert Bentonite Water
Solid Auger Hollow Stem Auger
- Was Outer Steel Casing Used? Yes No
Depth = _____ to _____ Feet.
- Borehole Diameter for Outer Casing _____ Inches.

WELL CONSTRUCTION INFORMATION:

- Type of Casing: PVC Galvanized Teflon
Stainless Other _____
- Type of Casing Joints: Screw-Couple Glue-Couple Other _____
- Type of Well Screen: PVC Galvanized
Stainless Teflon Other _____
- Diameter of Casing and Well Screens:
Casing 2 Inches, Screen 2 Inches.
- Slot Size of Screen: 10
- Type of Screen Perforation: Factory Slotted
Hacksaw Drilled Other _____
- Installed Protector Pipe w/Locks: Yes No

WELL DEVELOPMENT INFORMATION:

- How was Well Developed? Bailing Pumping
Air Surging (Air or Nitrogen) Other _____
- Time Spent on Well Development?
_____ / _____ Minutes/Hours
- Approximate Water Volume Removed? 110 Gallons
- Water Clarity Before Development? Clear
Turbid Opaque
- Water Clarity After Development? Clear
Turbid Opaque
- Did Water have Odor? Yes No
If Yes, Describe _____
- Did Water have any Color? Yes No
If Yes, Describe _____

WATER LEVEL INFORMATION:

Water Level Summary (From Top of Casing)
During Drilling 22 Ft. Date 4/8/98
Before Development 19.80' Ft. Date 4/17/98
After Development 19.90' Ft. Date 4/17/98

Driller/Firm WEBER Drill Rig Type MOBILE B-61 XD Date Installed 4/8/98
Drill Crew LEE ROBERTSON Well No. PC-18 Kerr-McGee Hydrologist J. Crawford

3" BLG

KERR-McGEE CORPORATION HYDROLOGY DEPARTMENT MONITORING WELL INSTALLATION DIAGRAM

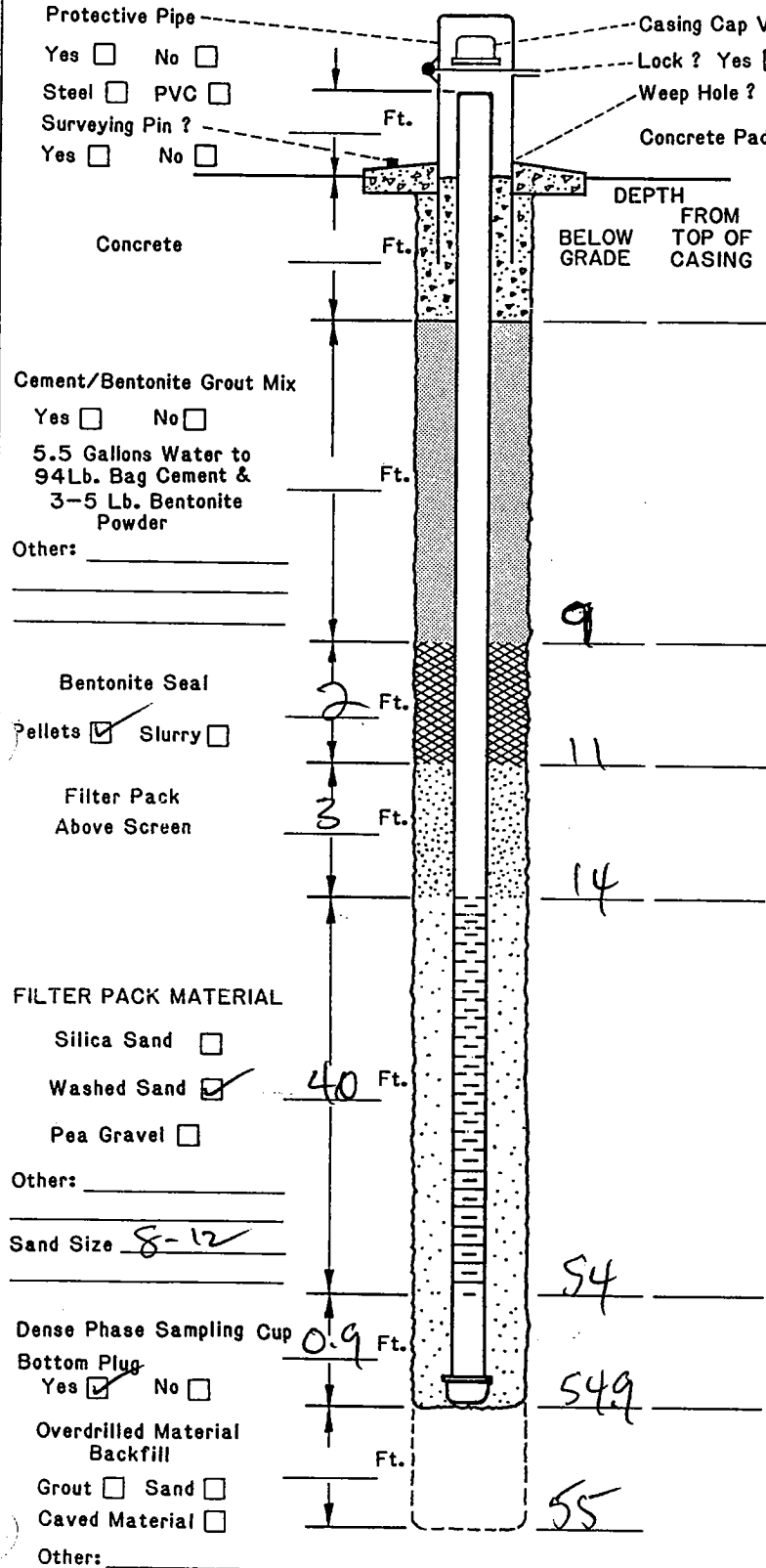

DRILLING INFORMATION:

- Borehole Diameter = 12 Inches.
- Were Drilling Additives Used? Yes No
Revert Bentonite Water
Solid Auger Hollow Stem Auger
- Was Outer Steel Casing Used? Yes No
Depth = _____ to _____ Feet.
- Borehole Diameter for Outer Casing _____ Inches.

WELL CONSTRUCTION INFORMATION:

- Type of Casing: PVC Galvanized Teflon
Stainless Other _____
- Type of Casing Joints: Screw-Couple Glue-Couple Other _____
- Type of Well Screen: PVC Galvanized
Stainless Teflon Other _____
- Diameter of Casing and Well Screens:
Casing 6 Inches, Screen 6 Inches.
- Slot Size of Screen: _____
- Type of Screen Perforation: Factory Slotted
Hacksaw Drilled Other _____
- Installed Protector Pipe w/Lock: Yes No

WELL DEVELOPMENT INFORMATION:

- How was Well Developed? Bailing Pumping
Air Surging (Air or Nitrogen) Other _____
- Time Spent on Well Development?
_____/_____/_____ Minutes/Hours
- Approximate Water Volume Removed? _____ Gallons
- Water Clarity Before Development? Clear
Turbid Opaque
- Water Clarity After Development? Clear
Turbid Opaque
- Did Water have Odor? Yes No
If Yes, Describe _____
- Did Water have any Color? Yes No
If Yes, Describe _____

WATER LEVEL INFORMATION: Water Level Summary (From Top of Casing)

During Drilling _____ Ft. Date _____
Before Development _____ Ft. Date _____
After Development _____ Ft. Date _____

Driller/Firm WEBER

Drill Rig Type MOBILE B-61

Date Installed 5/6/98

Drill Crew LEE ROBERTSON

Well No. PC 55

Kerr-McGee Hydrologist J. Crawford

TEST WELL PC-70

ADDENDUM D

**Tabulations and Graphs of Drawdown and Recovery Data and
Calculations of Aquifer Coefficients for Test Well PC-70**

**Drawdown Data For Pumping Well PC-70
Constant Discharge Test of Henderson Well PC-70
Kerr-McGee Henderson Facility, Henderson, NV
Test Date: September 14-17, 1998**

Pre-Test Water Level: 18.73 feet top of casing
Pumping Rate: 45gpm

Date	24 Hour Clock Time	Elapsed Time Since Test Started (minutes)	Depth to Water (feet)	Drawdown (feet)	Pumping Rate (gpm)	Remarks
9/14/98	1500	0	18.730	0.000	0	Static WL
	1500.5	0.5	20.450	1.720	45	
	1501	1	20.490	1.760	45	
	1502	2	20.500	1.770	45	
	1503	3	20.510	1.780	45	
	1504	4	20.515	1.785	45	
	1505	5	20.520	1.790	45	
	1506	6	20.530	1.800	45	
	1507	7	20.540	1.810	45	
	1508	8	20.540	1.810	45	
	1509	9	20.550	1.820	45	
	1510	10	20.555	1.825	45	
	1512	12	20.560	1.830	45	
	1514	14	20.570	1.840	45	
	1516	16	20.575	1.845	45	
	1518	18	20.580	1.850	45	
	1520	20	20.585	1.855	45	
	1525	25	20.590	1.860	45	
	1530	30	20.610	1.880	45	
	1540	40	20.640	1.910	45	
	1550	50	20.680	1.950	45	
	1600	60	20.690	1.960	45	
	1620	80	20.710	1.980	45	
	1640	100	20.730	2.000	45	
1700	120	20.740	2.010	45		
1730	150	20.760	2.030	45		
1800	180	20.780	2.050	45		
1900	240	20.810	2.080	45		
2000	300	20.830	2.100	45		
2122	382	20.860	2.130	45		
2200	420	20.880	2.150	45		
2300	480	20.890	2.160	45		
9/15/98	2400	540	20.900	2.170	45	
	0100	600	20.910	2.180	45	
	0200	660	20.920	2.190	45	
	0300	720	20.940	2.210	45	
	0400	780	20.950	2.220	45	
	0500	840	20.960	2.230	45	
	0600	900	20.970	2.240	45	
	0700	960	20.980	2.250	45	
	0800	1020	20.985	2.255	45	
	0900	1080	20.990	2.260	45	
	1000	1140	21.000	2.270	45	
	1100	1200	21.000	2.270	45	
	1200	1260	21.000	2.270	45	
	1300	1320	21.000	2.270	45	
	1400	1380	21.000	2.270	45	
	1500	1440	21.010	2.280	45	
	1600	1500	21.010	2.280	45	
	1700	1560	21.010	2.280	45	
	1800	1620	21.020	2.290	45	
	1920	1700	21.030	2.300	45	
	2000	1740	21.040	2.310	45	
	2100	1800	21.050	2.320	45	
	2200	1860	21.060	2.330	45	
	2300	1920	21.070	2.340	45	
9/16/98	2400	1980	21.070	2.340	45	
	0100	2040	21.070	2.340	45	
	0200	2100	21.070	2.340	45	
	0300	2160	21.070	2.340	45	
	0400	2220	21.080	2.350	45	
	0500	2280	21.080	2.350	45	
	0600	2340	21.080	2.350	45	
	0700	2400	21.080	2.350	45	
	0800	2460	21.090	2.360	45	
	0900	2520	21.090	2.360	45	
	1000	2580	21.090	2.360	45	
	1100	2640	21.090	2.360	45	
	1200	2700	21.090	2.360	45	
	1300	2760	21.090	2.360	45	
1400	2820	21.090	2.360	45		
1500	2880	21.090	2.360	45	Pump Off	

**Recovery Data for Pumping Well PC-70
Constant Discharge Test of Henderson Well PC-70
Kerr-McGee Henderson Facility, Henderson, NV
Test Date: September 14-17, 1998**

Pre-Test Water Level: 18.73 feet below top of casing
Pumping Rate: 45gpm

Date	24 Hour Clock Time	Time Since Pump Test Started (t, minutes)	Time Since Pump Stopped (t', minutes)	Ratio t/t'	Depth to Water (feet)	Residual Drawdown (s', feet)	Remarks
9/16/98	1500	2880.0	0.0	288000.0	21.090	2.360	Pump Off
	1500.5	2880.5	0.5	5761.0	19.290	0.560	
	1501	2881	1.0	2881.0	19.240	0.510	
	1502	2882	2.0	1441.0	19.220	0.490	
	1503	2883	3.0	961.0	19.205	0.475	
	1504	2884	4.0	721.0	19.200	0.470	
	1505	2885	5.0	577.0	19.190	0.460	
	1506	2886	6.0	481.0	19.180	0.450	
	1507	2887	7.0	412.4	19.170	0.440	
	1508	2888	8.0	361.0	19.160	0.430	
	1509	2889	9.0	321.0	19.155	0.425	
	1510	2890	10.0	289.0	19.150	0.420	
	1512	2892	12.0	241.0	19.140	0.410	
	1514	2894	14.0	206.7	19.140	0.410	
	1516	2896	16.0	181.0	19.130	0.400	
	1518	2898	18.0	161.0	19.125	0.395	
	1520	2900	20.0	145.0	19.120	0.390	
	1525	2905	25.0	116.2	19.100	0.370	
	1530	2910	30.0	97.0	19.090	0.360	
	1540	2920	40.0	73.0	19.060	0.330	
	1550	2930	50.0	58.6	19.050	0.320	
	1600	2940	60.0	49.0	19.040	0.310	
	1620	2960	80.0	37.0	19.020	0.290	
1640	2980	100.0	29.8	19.000	0.270		
1700	3000	120.0	25.0	18.990	0.260		
1730	3030	150.0	20.2	18.970	0.240		
1800	3060	180.0	17.0	18.950	0.220		
1930	3150	270.0	11.7	18.930	0.200		
2100	3240	360.0	9.0	18.920	0.190		
9/17/98	2400	3420	540.0	6.3	18.900	0.170	
	0500	3720	840.0	4.4	18.860	0.130	
	0700	3840	960.0	4.0	18.850	0.120	
	1000	4020	1140.0	3.5	18.830	0.100	
	1210	4150	1270.0	3.3	18.820	0.090	End of Test

ARITHMETIC PLOT OF DRAWDOWN AND RECOVERY DATA FOR TEST WELL PC-70
CONSTANT DISCHARGE TEST OF HENDERSON TEST WELL PC-70

Date of Test: September 14-17, 1998

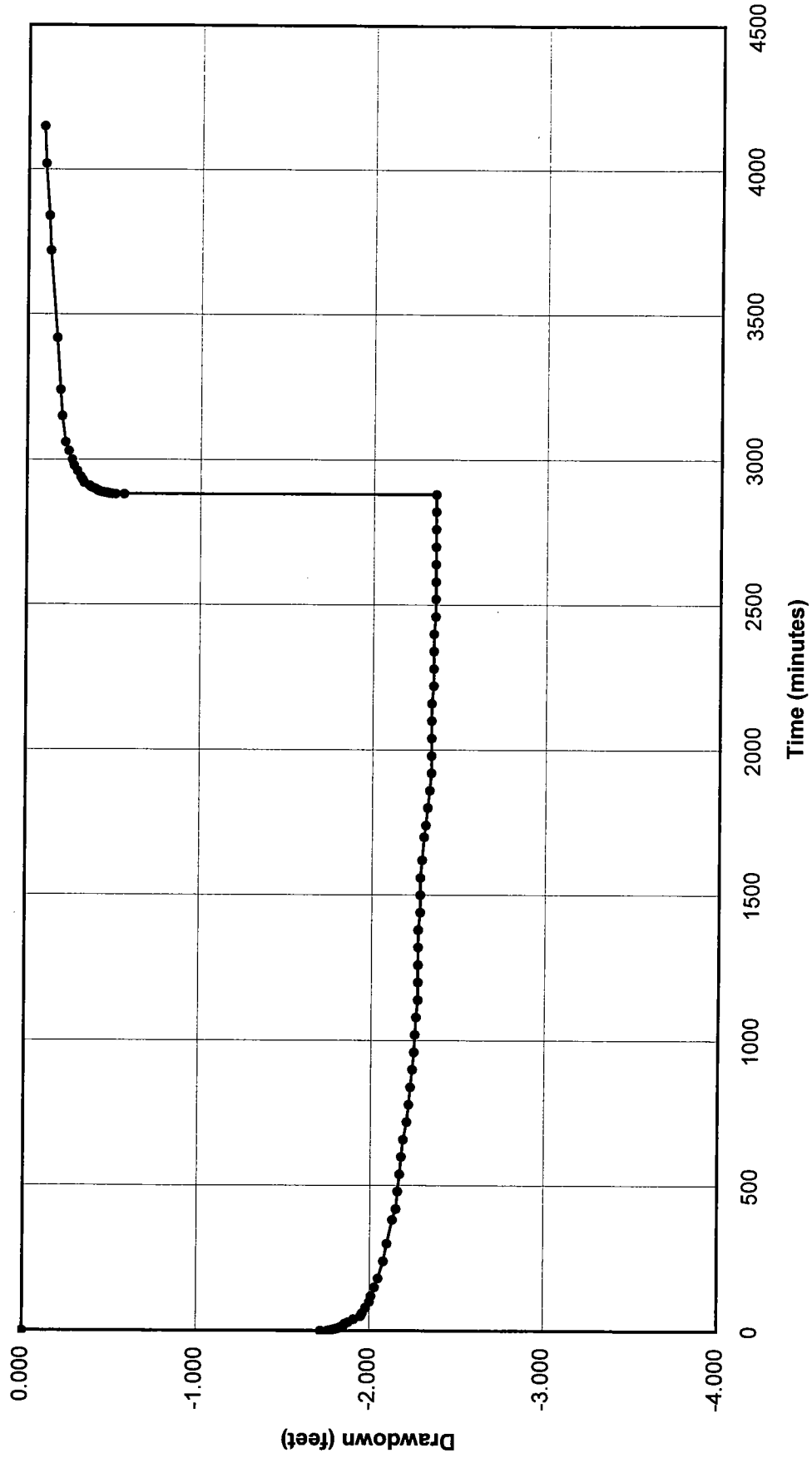

JACOBS SEMI-LOG ANALYSIS OF TIME vs DRAWDOWN DATA
FOR TEST WELL PC-70
CONSTANT DISCHARGE PUMPING TEST OF HENDERSON TEST WELL PC-70
Date of Test: September 14-17, 1998

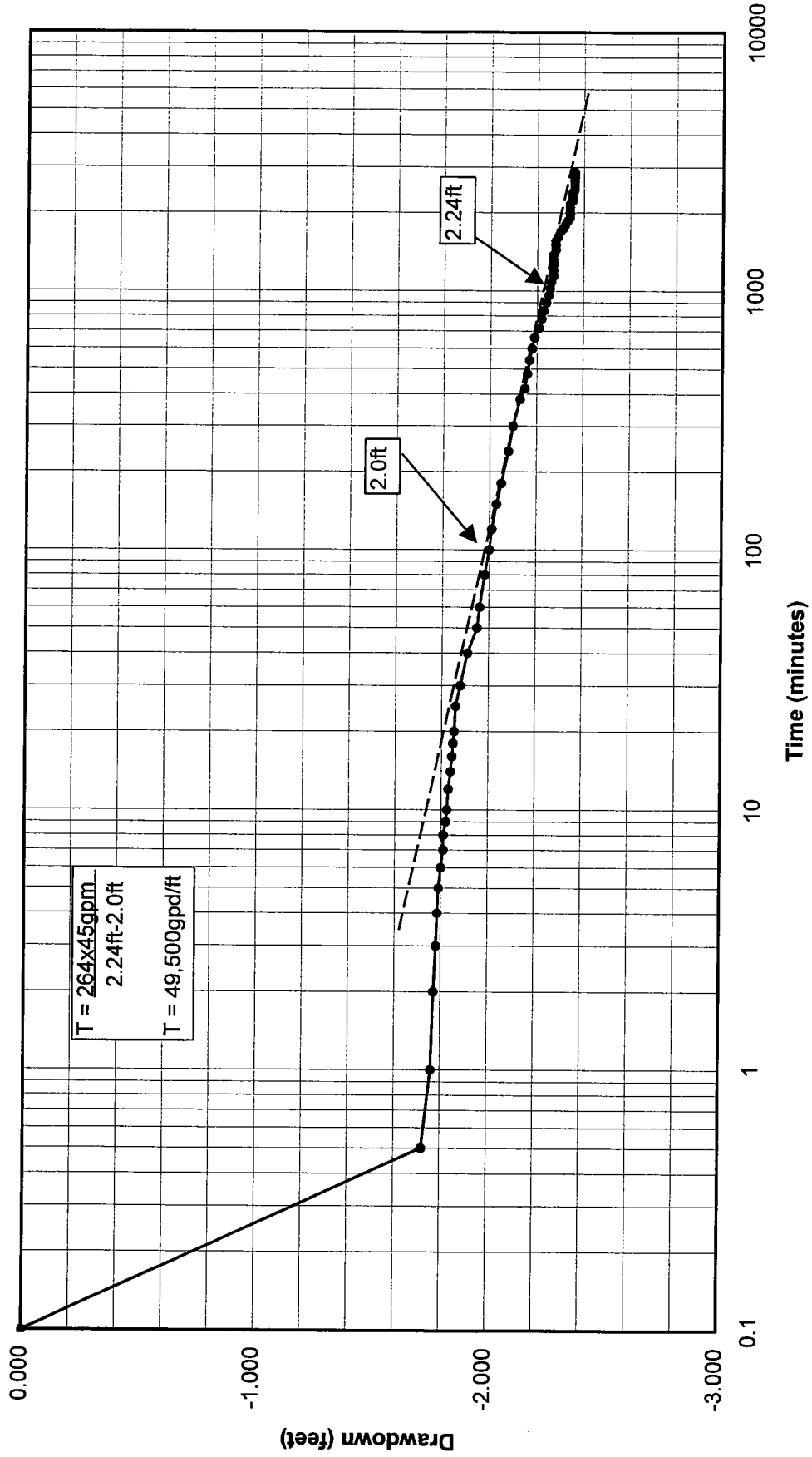

JACOBS SEMI-LOG ANALYSIS OF t/t' vs RESIDUAL DRAWDOWN DATA
 FOR TEST WELL PC-70
 CONSTANT DISCHARGE RECOVERY TEST OF HENDERSON TEST WELL PC-70
 Date of Recovery Test: September 16-17, 1998

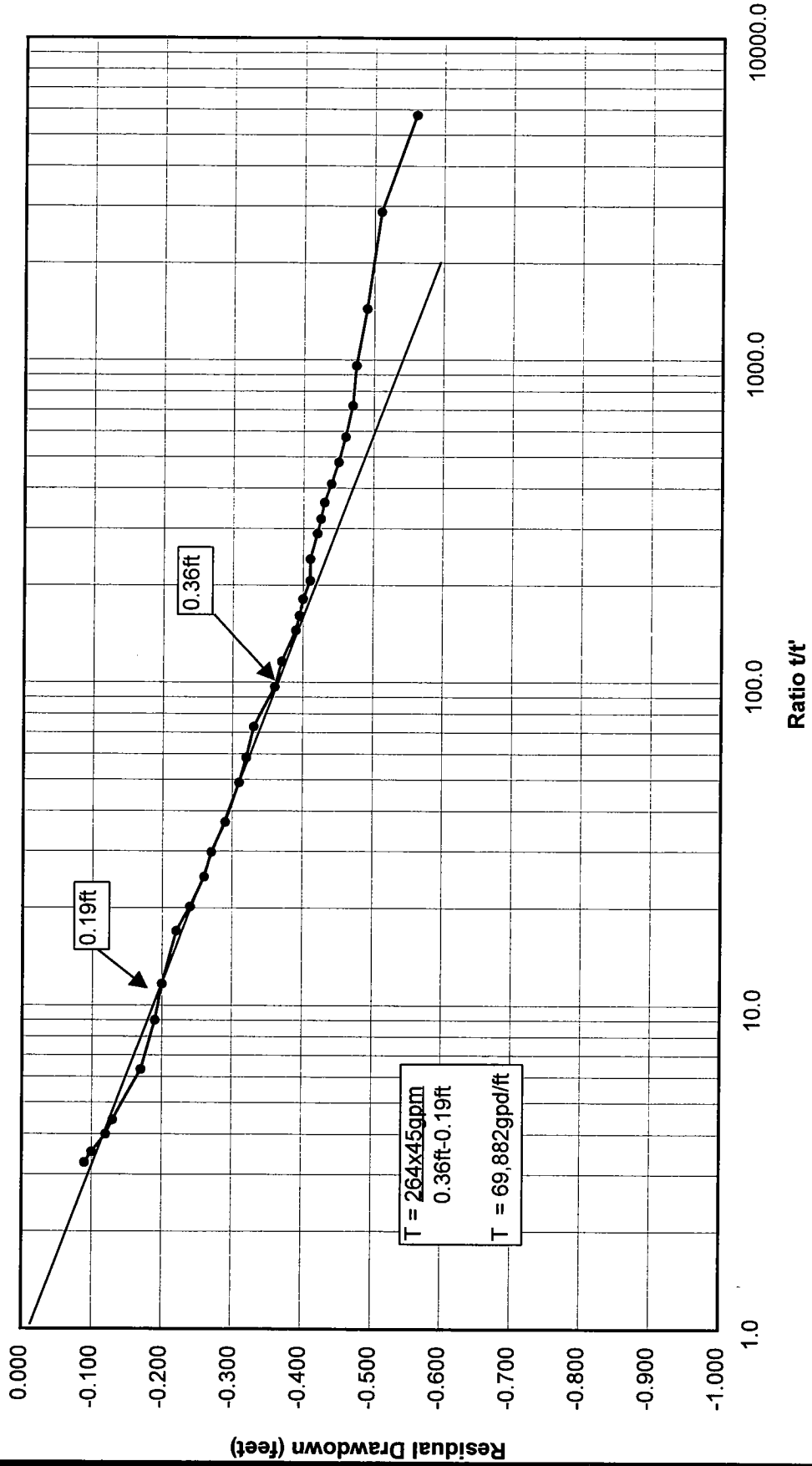

**CALCULATION OF AQUIFER COEFFICIENTS FOR TEST WELL PC-70
CONSTANT DISCHARGE PUMPING TEST
OF PITTMAN LATERAL TEST WELL PC-70**

Jacobs Semi-Log Straight-Line Analysis of Drawdown Data

Transmissivity = 49,500 gallons per day per foot
Permeability = 1,547 gallons per day per square foot
(49500/32 feet of saturation)
Hydraulic Conductivity = 207 feet per day (1547/7.48gallons per cubic foot)

Jacobs Semi-Log Straight-Line Analysis of Recovery Data

Transmissivity = 69,882 gallons per day per foot
Permeability = 2,184 gallons per day per square foot
(69882/32 feet of saturation)
Hydraulic Conductivity = 292 feet per day (2184/7.48gallons per cubic foot)

OB WELL PC-17

ADDENDUM E

**Tabulations and Graphs of Drawdown and Recovery Data and
Calculations of Aquifer Coefficients for Test Well PC-17**

**Drawdown Data For Observation Well PC-17
 Constant Discharge Test of Henderson Well PC-70
 Kerr-McGee Henderson Facility, Henderson, NV
 Test Date: September 14-17, 1998**

Pre-Test Water Level: 18.10 feet below top of casing
 Pumping Rate: 45gpm

Date	24 Hour Clock Time	Elapsed Time Since Test Started (minutes)	Depth to Water (feet)	Drawdown (feet)	Pumping Rate (gpm)	Remarks	
9/14/98	1500	0	18.100	0.000	0	Static WL	
	1502.5	2.5	18.300	0.200	45		
	1511	11	18.330	0.230	45		
	1515	15	18.340	0.240	45		
	1519	19	18.350	0.250	45		
	1521	21	18.350	0.250	45		
	1527	27	18.360	0.260	45		
	1531	31	18.380	0.280	45		
	1541	41	18.390	0.290	45		
	1553	53	18.410	0.310	45		
	1602	62	18.420	0.320	45		
	1623	83	18.430	0.330	45		
	1643	103	18.440	0.340	45		
	1703	123	18.460	0.360	45		
	1732	153	18.470	0.370	45		
	1802	182	18.490	0.390	45		
	1903	243	18.510	0.410	45		
	2002	302	18.530	0.430	45		
	2123	383	18.550	0.450	45		
	2205	425	18.560	0.460	45		
	2302	482	18.570	0.470	45		
	9/15/98	0002	542	18.580	0.480		45
		0102	602	18.585	0.485		45
0202		662	18.590	0.490	45		
0302		722	18.595	0.495	45		
0402		782	18.600	0.500	45		
0502		842	18.610	0.510	45		
0602		902	18.620	0.520	45		
0702		962	18.620	0.520	45		
0802		1022	18.630	0.530	45		
0902		1082	18.630	0.530	45		
1002		1142	18.635	0.535	45		
1102		1202	18.640	0.540	45		
1202		1262	18.650	0.550	45		
1302		1322	18.650	0.550	45		
1402		1382	18.660	0.560	45		
1502		1442	18.660	0.560	45		
1602		1502	18.660	0.565	45		
1702		1562	18.665	0.565	45		
1802		1622	18.665	0.565	45		
1902		1682	18.670	0.570	45		
2002		1742	18.680	0.580	45		
2102		1802	18.685	0.585	45		
2202		1862	18.690	0.590	45		
2302	1922	18.690	0.590	45			
9/16/98	0002	1982	18.690	0.595	45		
	0102	2042	18.700	0.600	45		
	0202	2102	18.700	0.600	45		
	0302	2162	18.700	0.605	45		
	0402	2222	18.700	0.605	45		
	0502	2282	18.700	0.605	45		
	0602	2342	18.710	0.610	45		
	0702	2402	18.710	0.610	45		
	0802	2462	18.730	0.615	45		
	0902	2522	18.730	0.615	45		
	1002	2582	18.730	0.620	45		
	1102	2642	18.730	0.620	45		
	1202	2702	18.730	0.625	45		
	1302	2762	18.730	0.625	45		
	1402	2822	18.730	0.630	45		
1500	2880	18.730	0.630	45	Pump Off		

**Recovery Data for Observation Well PC-17
 Constant Discharge Test of Henderson Well PC-70
 Kerr-McGee Henderson Facility, Henderson, NV
 Test Date: September 14-17, 1998**

Pre-Test Water Level: 18.10 feet below top of casing
 Pumping Rate: 45gpm

Date	24 Hour Clock Time	Time Since Pump Test Started (t, minutes)	Time Since Pump Stopped (t', minutes)	Ratio t/t'	Depth to Water (feet)	Residual Drawdown (s', feet)	Remarks
9/16/98	1500	2880	0.0	288000.0	18.730	0.630	Pump Off Recovery
	1511	2891	11.0	262.8	18.480	0.380	
	1517	2897	17.0	170.4	18.470	0.370	
	1526	2906	26.0	111.8	18.440	0.340	
	1536	2916	36.0	81.0	18.430	0.330	
	1546	2926	46.0	63.6	18.420	0.320	
	1556	2936	56.0	52.4	18.410	0.310	
	1616	2956	76.0	38.9	18.380	0.280	
	1640	2980	100.0	29.8	18.370	0.270	
	1700	3000	120.0	25.0	18.360	0.260	
	1730	3030	150.0	20.2	18.350	0.250	
	1800	3060	180.0	17.0	18.330	0.230	
	1930	3120	240.0	13.0	18.310	0.210	
	2100	3240	360.0	9.0	18.300	0.200	
9/17/98	2400	3420	540.0	6.3	18.280	0.180	End of Test
	0500	3720	840.0	4.4	18.240	0.140	
	0700	3840	960.0	4.0	18.220	0.120	
	1000	4020	1140.0	3.5	18.190	0.090	
	1210	4150	1270.0	3.3	18.170	0.070	

**Drawdown Data For Observation Well PC-18
Constant Discharge Test of Henderson Well PC-70
Kerr-McGee Henderson Facility, Henderson, NV
Test Date: September 14-17, 1998**

Pre-Test Water Level: 19.42 feet top of casing
Pumping Rate: 45gpm

Date	24 Hour Clock Time	Elapsed Time Since Test Started (minutes)	Depth to Water (feet)	Drawdown (feet)	Pumping Rate (gpm)	Remarks
9/14/98	1500	0	19.420	0.001	0	Static WL
	1513	13	19.490	0.070	45	
	1517	17	19.500	0.080	45	
	1522	22	19.510	0.090	45	
	1528	28	19.510	0.090	45	
	1533	33	19.520	0.100	45	
	1543	43	19.530	0.110	45	
	1555	55	19.540	0.120	45	
	1604	64	19.550	0.130	45	
	1625	85	19.560	0.140	45	
	1645	105	19.560	0.140	45	
	1705	125	19.570	0.150	45	
	1734	154	19.590	0.170	45	
	1804	184	19.600	0.180	45	
	1905	245	19.620	0.200	45	
	2005	305	19.640	0.220	45	
	2125	385	19.650	0.230	45	
	2207	427	19.670	0.250	45	
	2304	484	19.670	0.250	45	
	9/15/98	0004	544	19.690	0.270	
0104		604	19.700	0.280	45	
0204		664	19.705	0.285	45	
0304		724	19.710	0.290	45	
0404		784	19.715	0.295	45	
0504		844	19.720	0.300	45	
0604		904	19.730	0.310	45	
0704		964	19.730	0.310	45	
0804		1024	19.740	0.320	45	
0904		1084	19.750	0.330	45	
1004		1144	19.760	0.340	45	
1104		1204	19.770	0.350	45	
1204		1264	19.770	0.350	45	
1304		1324	19.770	0.350	45	
1404		1384	19.770	0.350	45	
1504		1444	19.770	0.350	45	
1604		1504	19.770	0.350	45	
1704		1564	19.770	0.350	45	
1804		1624	19.770	0.350	45	
1904		1684	19.775	0.355	45	
2004	1744	19.775	0.355	45		
2104	1804	19.780	0.360	45		
2204	1864	19.790	0.370	45		
2304	1924	19.790	0.370	45		
9/16/98	0004	1984	19.790	0.370	45	
	0104	2044	19.800	0.380	45	
	0204	2104	19.800	0.380	45	
	0304	2164	19.800	0.380	45	
	0404	2224	19.810	0.390	45	
	0504	2284	19.810	0.390	45	
	0604	2344	19.810	0.390	45	
	0704	2404	19.820	0.400	45	
	0804	2464	19.820	0.400	45	
	0904	2524	19.830	0.410	45	
	1004	2584	19.830	0.410	45	
	1104	2644	19.830	0.410	45	
	1204	2704	19.830	0.410	45	
	1304	2764	19.835	0.415	45	
	1404	2824	19.835	0.415	45	
	1500	2880	19.840	0.420	45	Pump Off

ARITHMETIC PLOT OF DRAWDOWN AND RECOVERY DATA
FOR OBSERVATION WELL PC-17
CONSTANT DISCHARGE TEST OF HENDERSON MONITOR WELL PC-70
Date of Test: September 14-17, 1998

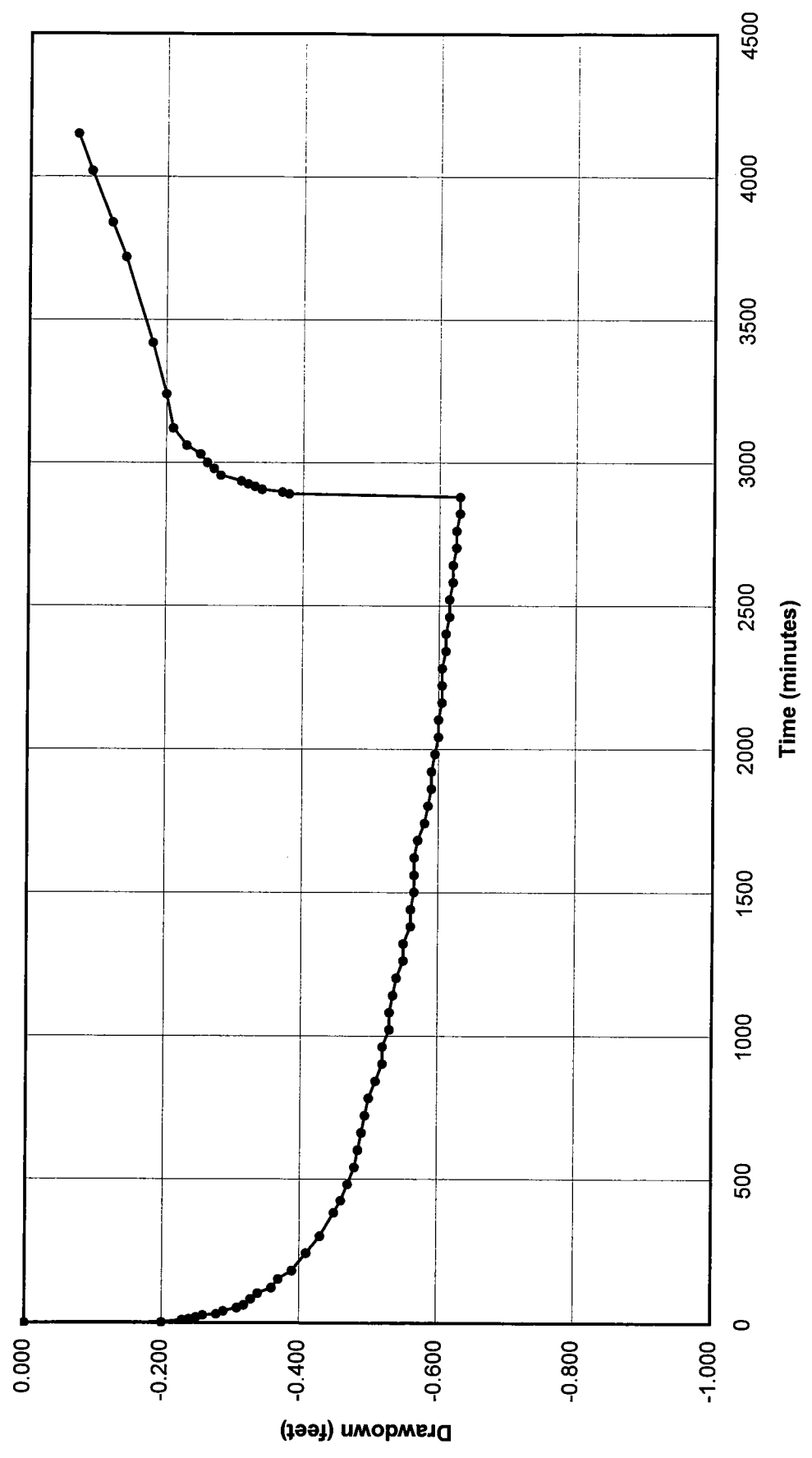

**SEMI-LOG PLOT OF TIME vs DRAWDOWN DATA FOR OBSERVATION WELL PC-17
 CONSTANT DISCHARGE PUMPING TEST OF HENDERSON TEST WELL PC-70**

Date of Test: September 14-16, 1998

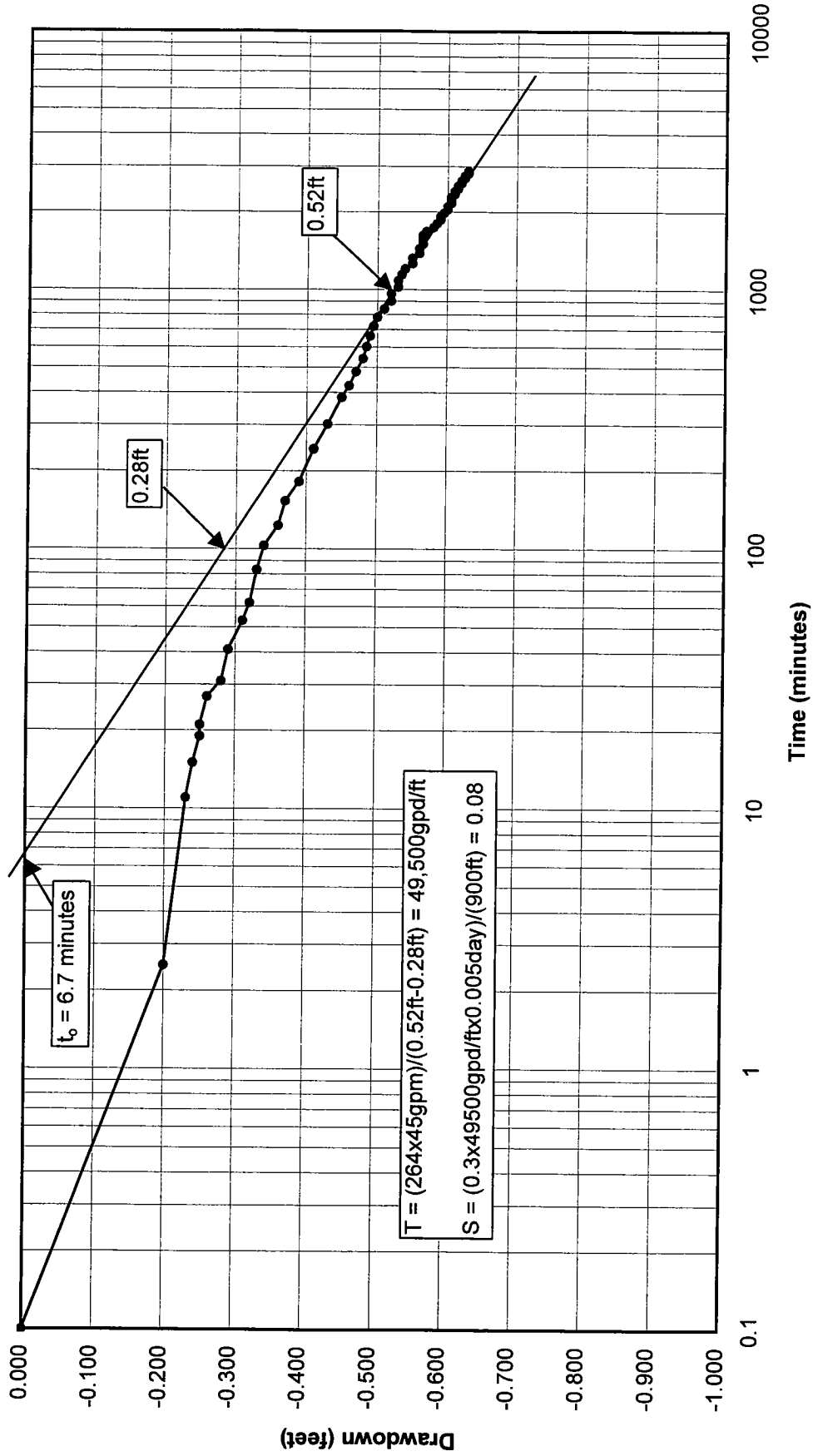

THEIS TYPE-CURVE ANALYSIS
LOG-LOG PLOT OF TIME vs DRAWDOWN DATA FOR OBSERVATION WELL PC-17
CONSTANT DISCHARGE PUMPING TEST OF HENDERSON TEST WELL PC-70

Date of Test: September 14-16, 1998

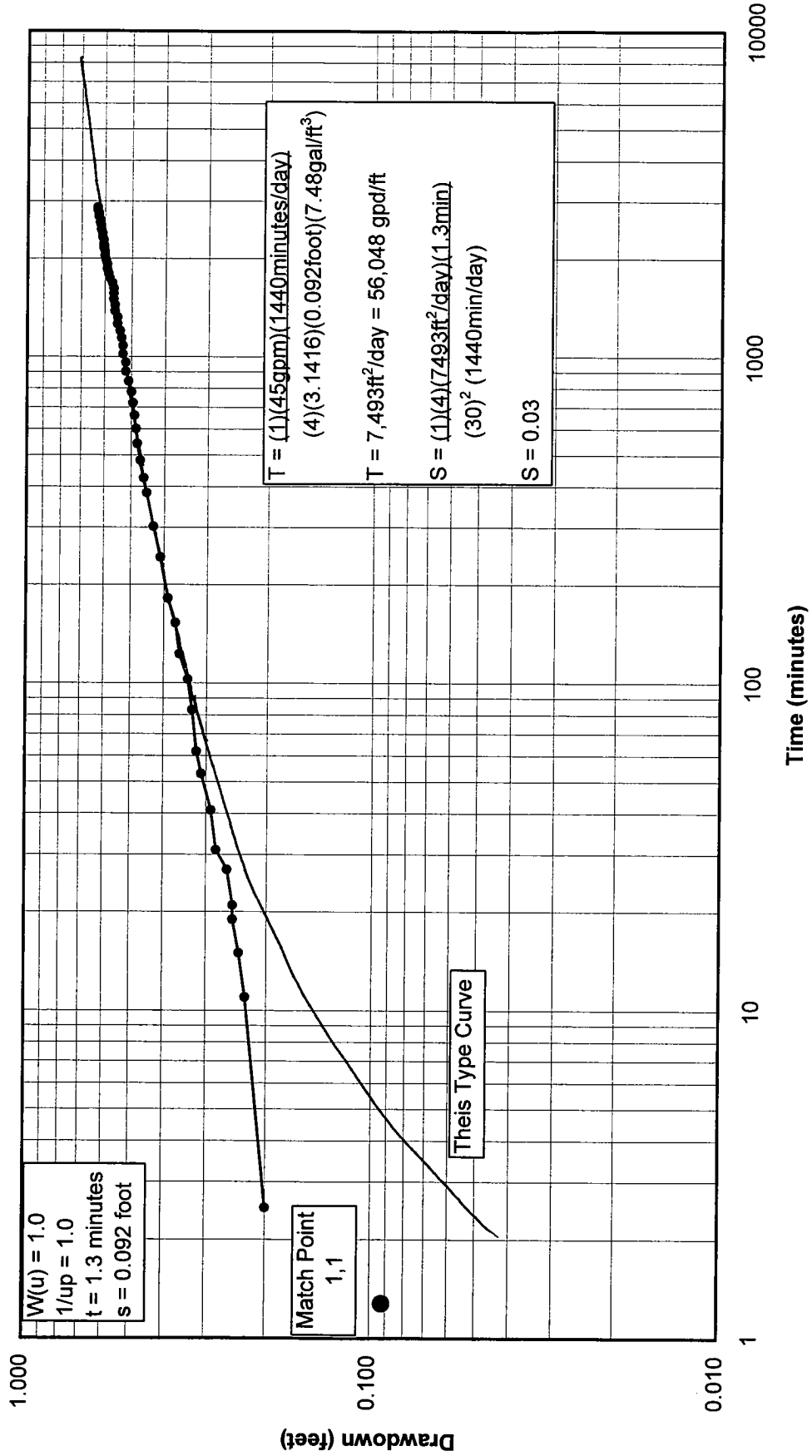

BOULTON DELAYED DRAINAGE ANALYSIS
LOG-LOG PLOT OF TIME vs DRAWDOWN DATA FOR OBSERVATION WELL PC-17
CONSTANT DISCHARGE PUMPING TEST OF HENDERSON TEST WELL PC-70

Date of Test: September 14-16, 1998

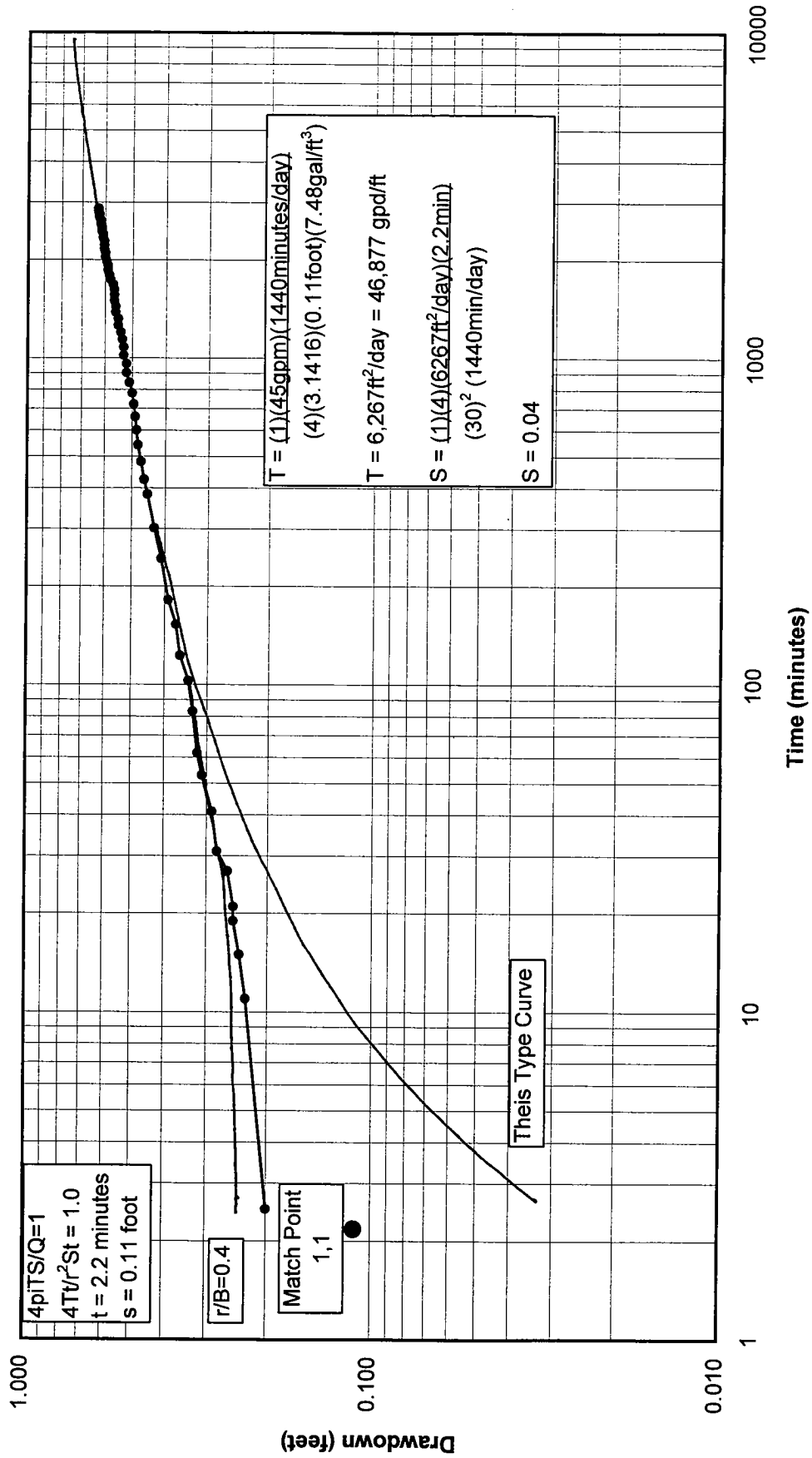

**JACOBS SEMI-LOG ANALYSIS OF t/t' vs RESIDUAL DRAWDOWN DATA
 FOR OBSERVATION WELL PC-17
 CONSTANT DISCHARGE RECOVERY TEST OF HENDERSON TEST WELL PC-70
 Date of Recovery Test: September 16-17, 1998**

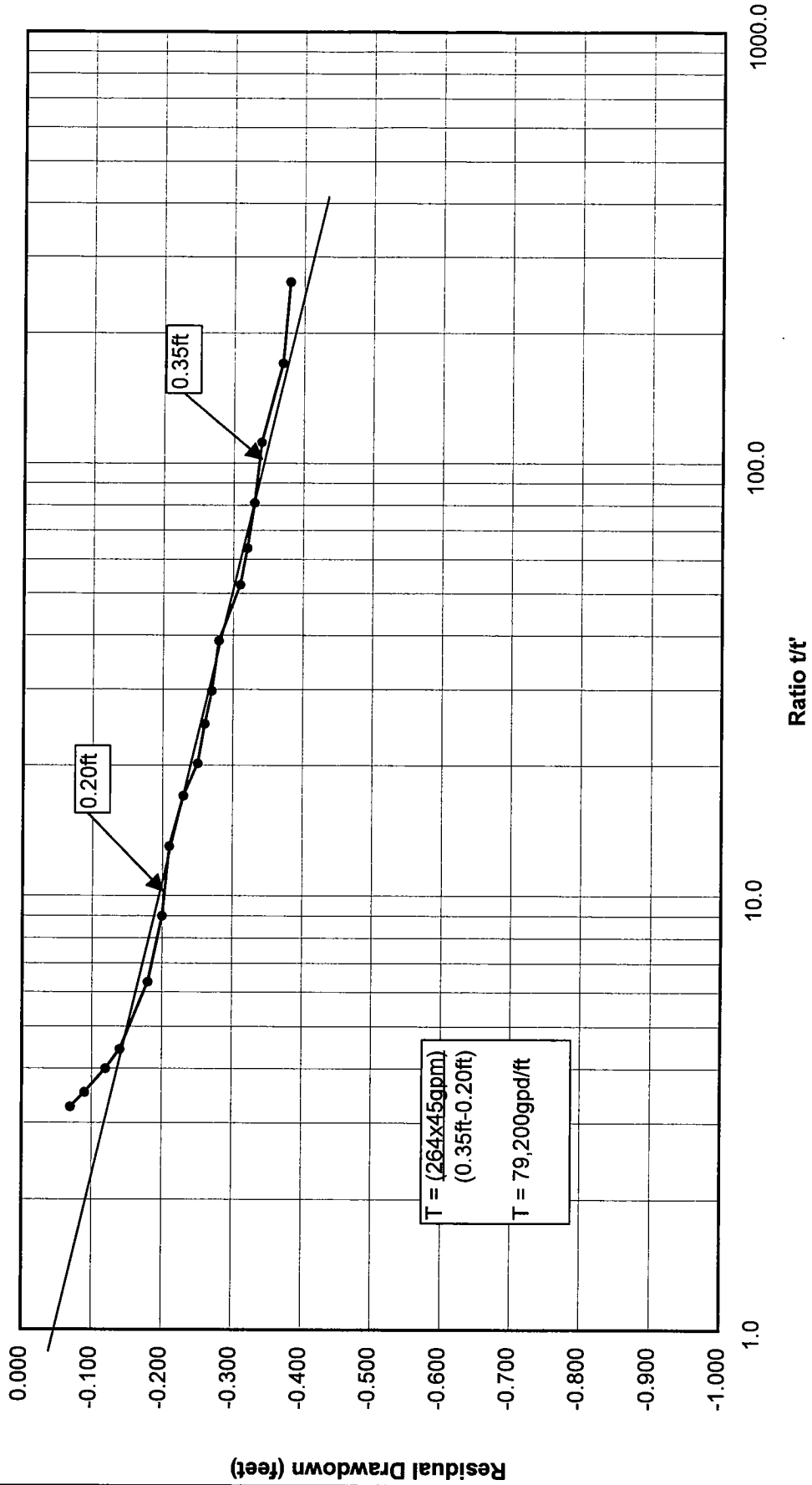

**CALCULATION OF AQUIFER COEFFICIENTS FOR OBSERVATION WELL PC-17
CONSTANT DISCHARGE PUMPING TEST
OF PITTMAN LATERAL TEST WELL PC-70**

Jacobs Semi-Log Straight-Line Analysis of Drawdown Data

Transmissivity = 49,500 gallons per day per foot
Permeability = 1,500 gallons per day per square foot
(49500/33 feet of saturation)
Hydraulic Conductivity = 201 feet per day (1500/7.48gallons per cubic foot)
Storage Coefficient = 0.08

Theis Log-Log Type Curve Match Analysis of Drawdown Data

Transmissivity = 56,048 gallons per day per foot
Permeability = 1,698 gallons per day per square foot
(56048/33 feet of saturation)
Hydraulic Conductivity = 227 feet per day (1698/7.48gallons per cubic foot)
Storage Coefficient = 0.08

Boulton Log-Log Delayed Drainage Curve Match Analysis of Drawdown Data

Transmissivity = 46,877 gallons per day per foot
Permeability = 1,421 gallons per day per square foot
(46877/33 feet of saturation)
Hydraulic Conductivity = 190 feet per day (1421/7.48gallons per cubic foot)
Storage Coefficient = 0.09

Jacobs Semi-Log Straight-Line Analysis of Recovery Data

Transmissivity = 79,200 gallons per day per foot
Permeability = 2,400 gallons per day per square foot
(79200/33 feet of saturation)
Hydraulic Conductivity = 321 feet per day (2400/7.48gallons per cubic foot)

OB WELL PC-18

ADDENDUM F

**Tabulations and Graphs of Drawdown and Recovery Data and
Calculations of Aquifer Coefficients for Test Well PC-18**

**Drawdown Data For Observation Well PC-18
Constant Discharge Test of Henderson Well PC-70
Kerr-McGee Henderson Facility, Henderson, NV
Test Date: September 14-17, 1998**

Pre-Test Water Level: 19.42 feet top of casing
Pumping Rate: 45gpm

Date	24 Hour Clock Time	Elapsed Time Since Test Started (minutes)	Depth to Water (feet)	Drawdown (feet)	Pumping Rate (gpm)	Remarks
9/14/98	1500	0	19.420	0.001	0	Static WL
	1513	13	19.490	0.070	45	
	1517	17	19.500	0.080	45	
	1522	22	19.510	0.090	45	
	1528	28	19.510	0.090	45	
	1533	33	19.520	0.100	45	
	1543	43	19.530	0.110	45	
	1555	55	19.540	0.120	45	
	1604	64	19.550	0.130	45	
	1625	85	19.560	0.140	45	
	1645	105	19.560	0.140	45	
	1705	125	19.570	0.150	45	
	1734	154	19.590	0.170	45	
	1804	184	19.600	0.180	45	
	1905	245	19.620	0.200	45	
	2005	305	19.640	0.220	45	
	2125	385	19.650	0.230	45	
	2207	427	19.670	0.250	45	
	2304	484	19.670	0.250	45	
	9/15/98	0004	544	19.690	0.270	
0104		604	19.700	0.280	45	
0204		664	19.705	0.285	45	
0304		724	19.710	0.290	45	
0404		784	19.715	0.295	45	
0504		844	19.720	0.300	45	
0604		904	19.730	0.310	45	
0704		964	19.730	0.310	45	
0804		1024	19.740	0.320	45	
0904		1084	19.750	0.330	45	
1004		1144	19.760	0.340	45	
1104		1204	19.770	0.350	45	
1204		1264	19.770	0.350	45	
1304		1324	19.770	0.350	45	
1404		1384	19.770	0.350	45	
1504		1444	19.770	0.350	45	
1604		1504	19.770	0.350	45	
1704		1564	19.770	0.350	45	
1804		1624	19.770	0.350	45	
1904		1684	19.775	0.355	45	
2004	1744	19.775	0.355	45		
2104	1804	19.780	0.360	45		
2204	1864	19.790	0.370	45		
2304	1924	19.790	0.370	45		
9/16/98	0004	1984	19.790	0.370	45	
	0104	2044	19.800	0.380	45	
	0204	2104	19.800	0.380	45	
	0304	2164	19.800	0.380	45	
	0404	2224	19.810	0.390	45	
	0504	2284	19.810	0.390	45	
	0604	2344	19.810	0.390	45	
	0704	2404	19.820	0.400	45	
	0804	2464	19.820	0.400	45	
	0904	2524	19.830	0.410	45	
	1004	2584	19.830	0.410	45	
	1104	2644	19.830	0.410	45	
	1204	2704	19.830	0.410	45	
	1304	2764	19.835	0.415	45	
	1404	2824	19.835	0.415	45	
1500	2880	19.840	0.420	45	Pump Off	

**Recovery Data for Observation Well PC-18
Constant Discharge Test of Henderson Well PC-70
Kerr-McGee Henderson Facility, Henderson, NV
Test Date: September 14-17, 1998**

Pre-Test Water Level: 19.42 feet below top of casing
Pumping Rate: 45gpm

Date	24 Hour Clock Time	Time Since Pump Test Started (t, minutes)	Time Since Pump Stopped (t', minutes)	Ratio t/t'	Depth to Water (feet)	Residual Drawdown (s', feet)	Remarks
9/16/98	1500	2880	0.0	288000.0	19.840	0.420	Pump Off Recovery
	1513	2893	13.0	222.5	19.730	0.310	
	1519	2899	19.0	152.6	19.710	0.290	
	1527	2907	27.0	107.7	19.705	0.285	
	1538	2918	38.0	76.8	19.700	0.280	
	1548	2928	48.0	61.0	19.690	0.270	
	1558	2938	58.0	50.7	19.680	0.260	
	1618	2958	78.0	37.9	19.670	0.250	
	1640	2980	100.0	29.8	19.660	0.240	
	1700	3000	120.0	25.0	19.650	0.230	
	1730	3030	150.0	20.2	19.640	0.220	
	1800	3060	180.0	17.0	19.630	0.210	
	1930	3150	270.0	11.7	19.610	0.190	
	2100	3240	360.0	9.0	19.600	0.180	
	9/17/98	2400	3420	540.0	6.3	19.580	
0500		3720	840.0	4.4	19.550	0.130	
0700		3840	960.0	4.0	19.540	0.120	
1000		4020	1140.0	3.3	19.520	0.100	
1210		4150	1270.0	3.0	19.510	0.090	End of Test

ARITHMETIC PLOT OF DRAWDOWN AND RECOVERY DATA
FOR OBSERVATION WELL PC-18
CONSTANT DISCHARGE TEST OF HENDERSON MONITOR WELL PC-70
Date of Test: September 14-17, 1998

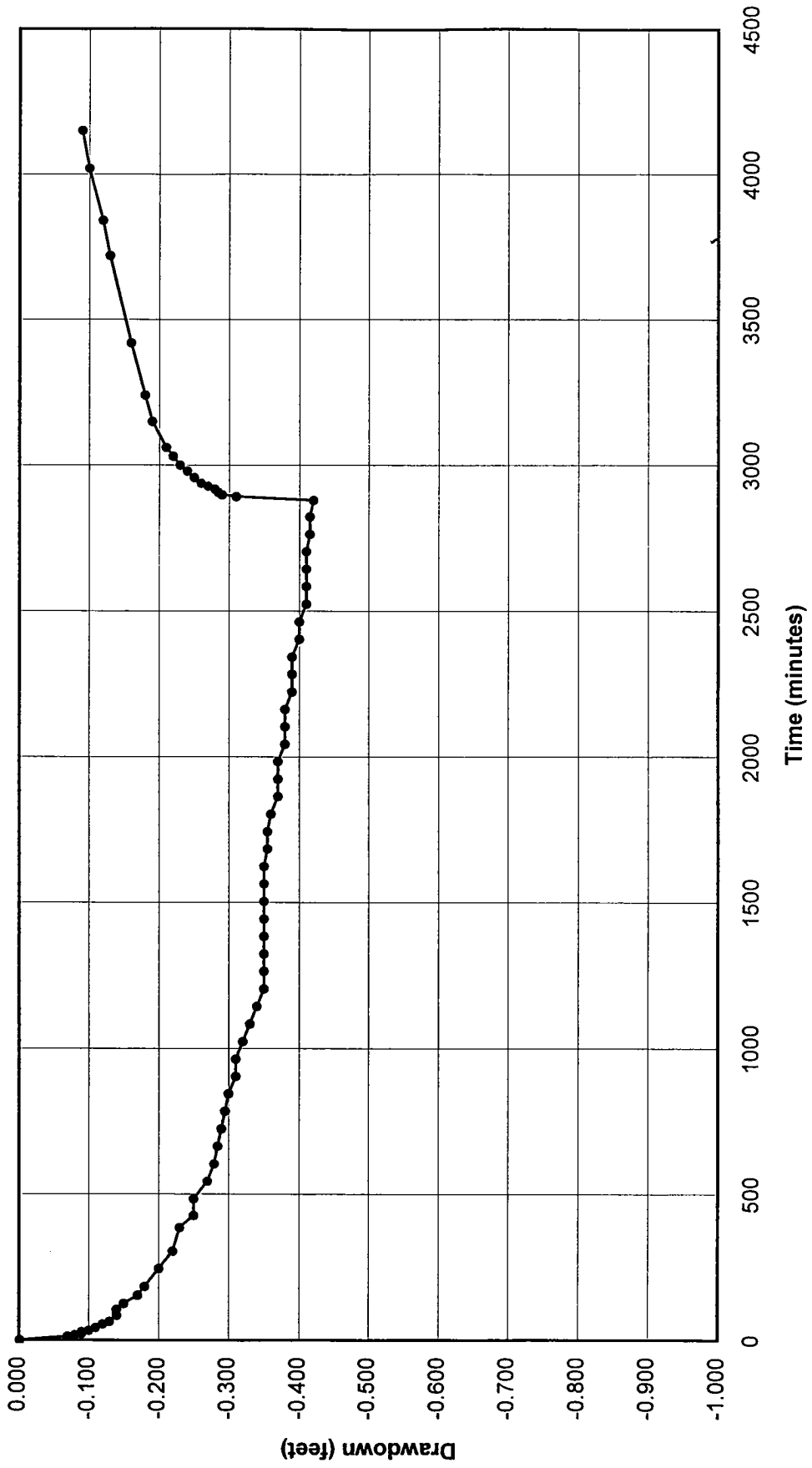

**JACOBS SEMI-LOG ANALYSIS OF TIME vs DRAWDOWN
FOR OBSERVATION WELL PC-18
CONSTANT DISCHARGE PUMPING TEST OF HENDERSON TEST WELL PC-70
Date of Test: September 14-17, 1998**

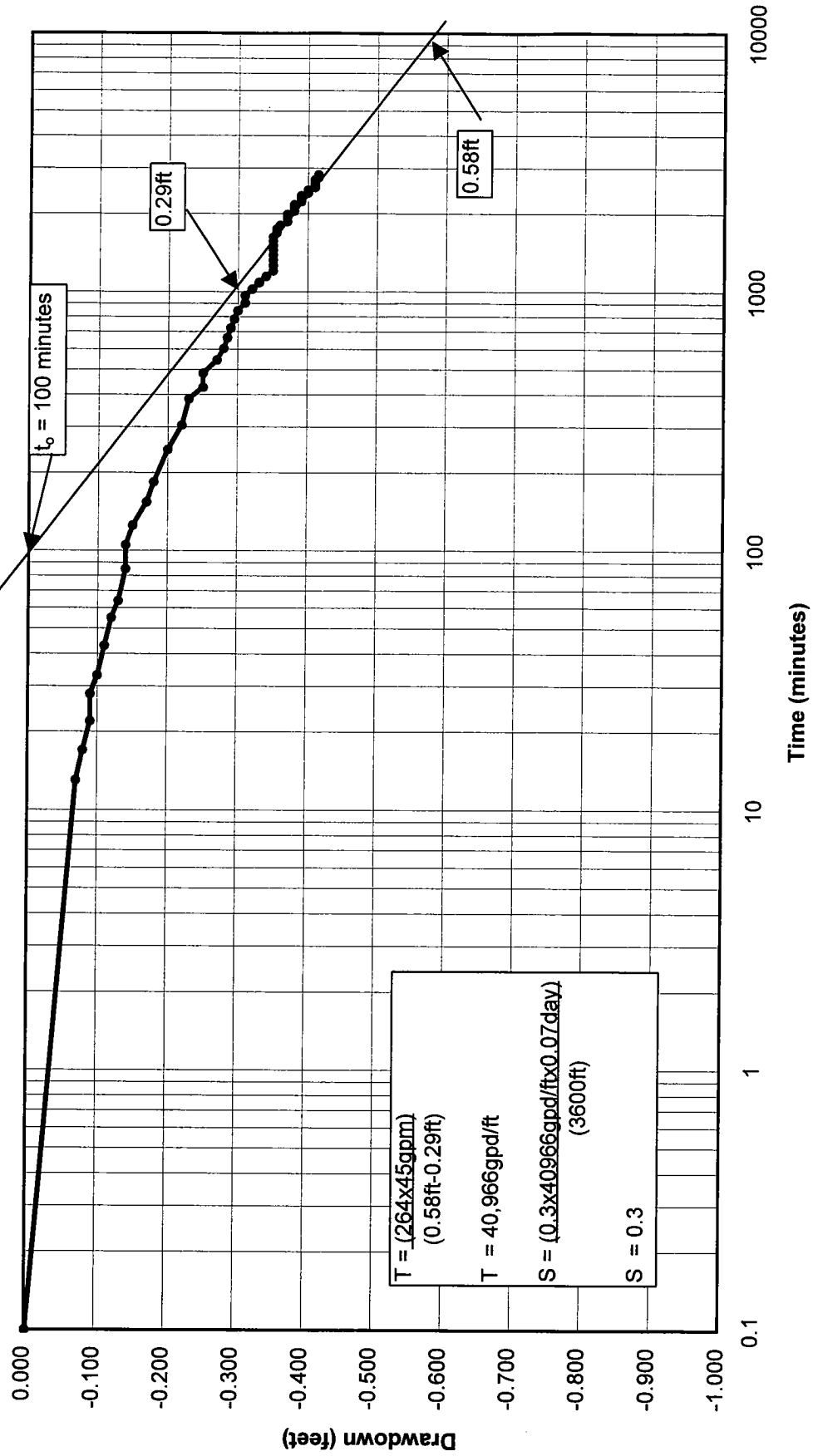

THEIS TYPE-CURVE ANALYSIS
LOG-LOG PLOT OF TIME vs DRAWDOWN FOR OBSERVATION WELL PC-18
CONSTANT DISCHARGE PUMPING TEST OF HENDERSON TEST WELL PC-70

Date of Test: September 14-17, 1998

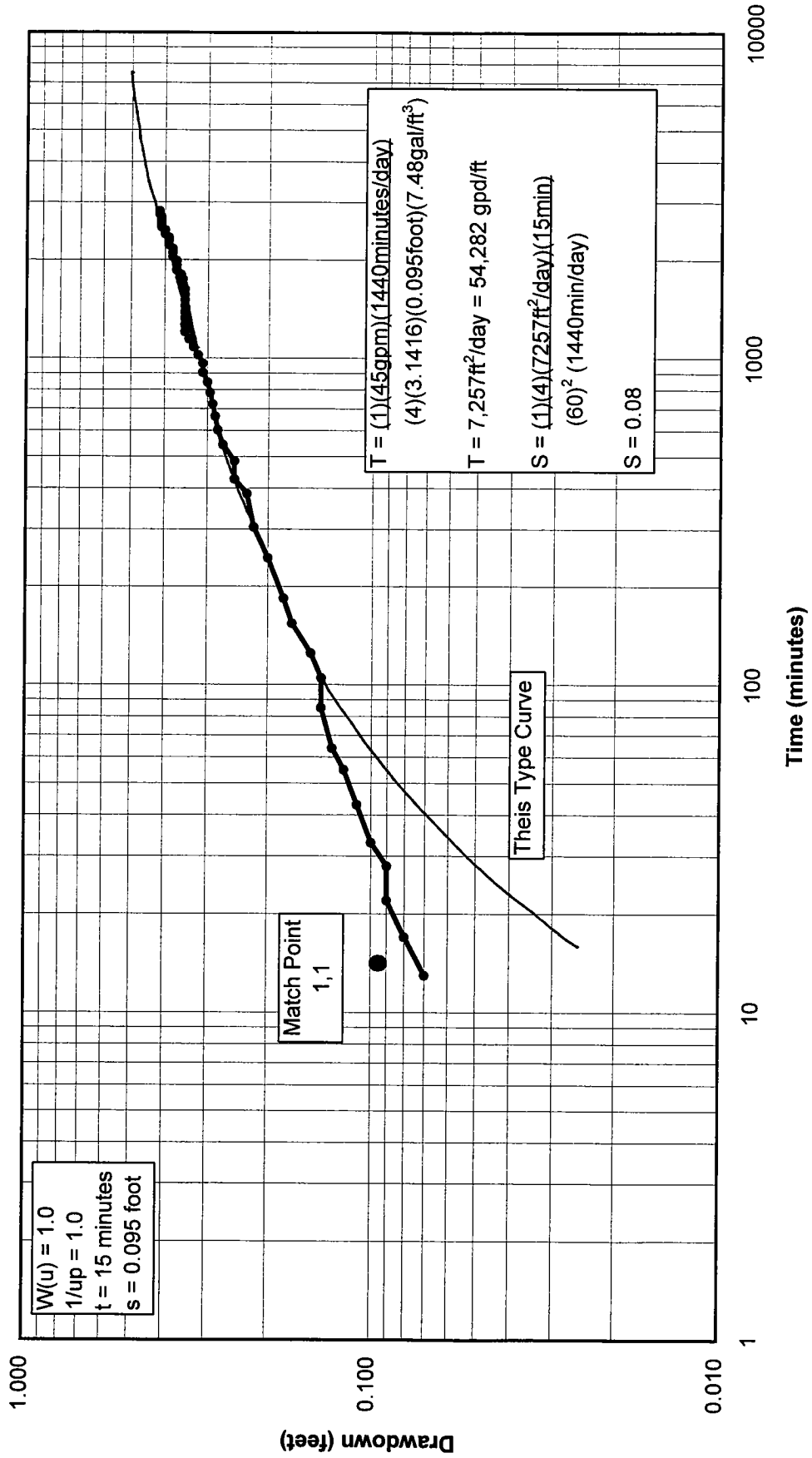

**BOULTON DELAYED DRAINAGE ANALYSIS
LOG-LOG PLOT OF TIME vs DRAWDOWN FOR OBSERVATION WELL PC-18
CONSTANT DISCHARGE PUMPING TEST OF HENDERSON TEST WELL PC-70**

Date of Test: September 14-17, 1998

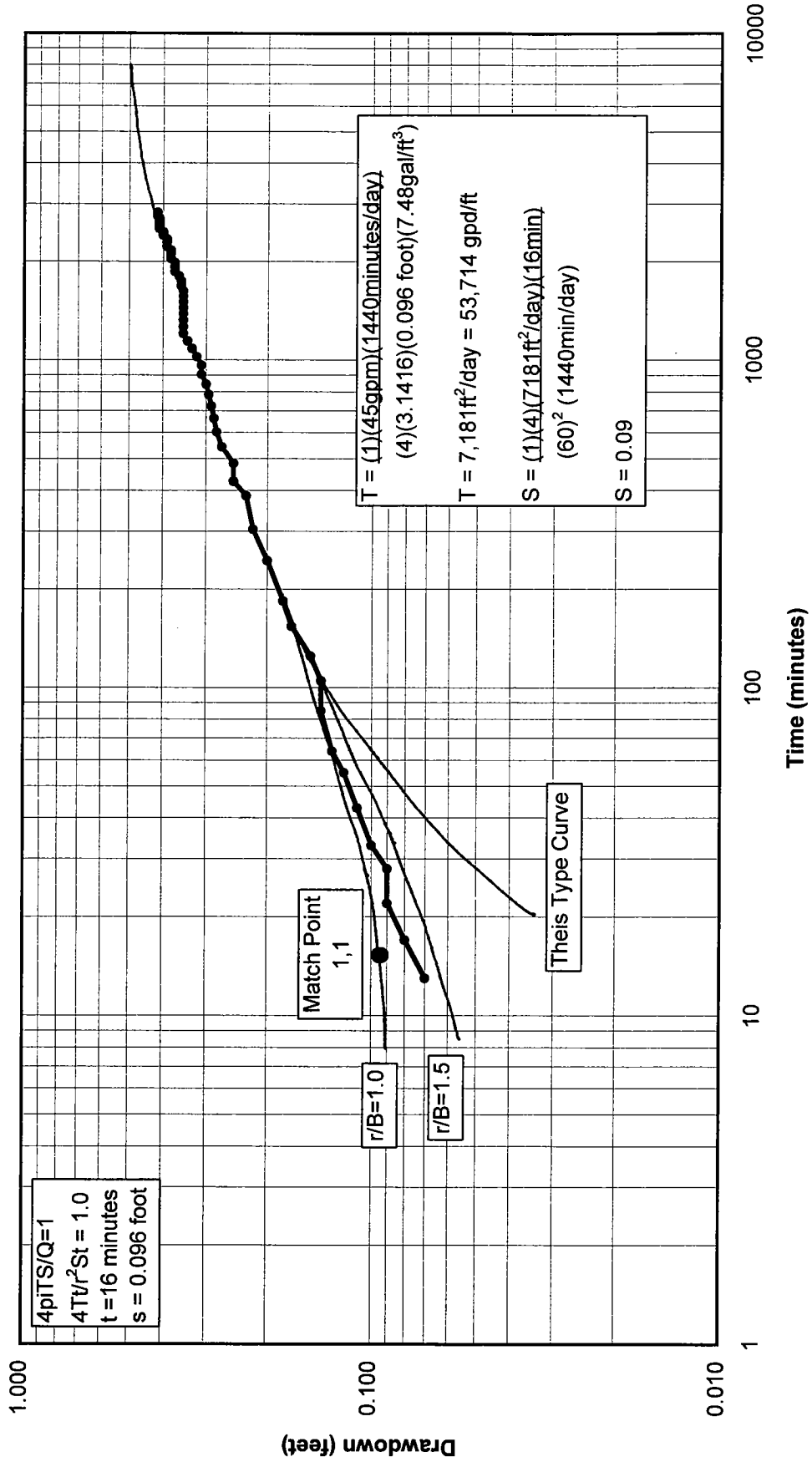

**JACOBS SEMI-LOG ANALYSIS OF t/t' vs RESIDUAL DRAWDOWN DATA
FOR OBSERVATION WELL PC-18
CONSTANT DISCHARGE RECOVERY TEST OF HENDERSON TEST WELL PC-70
Date of Recovery Test: September 16-17, 1998**

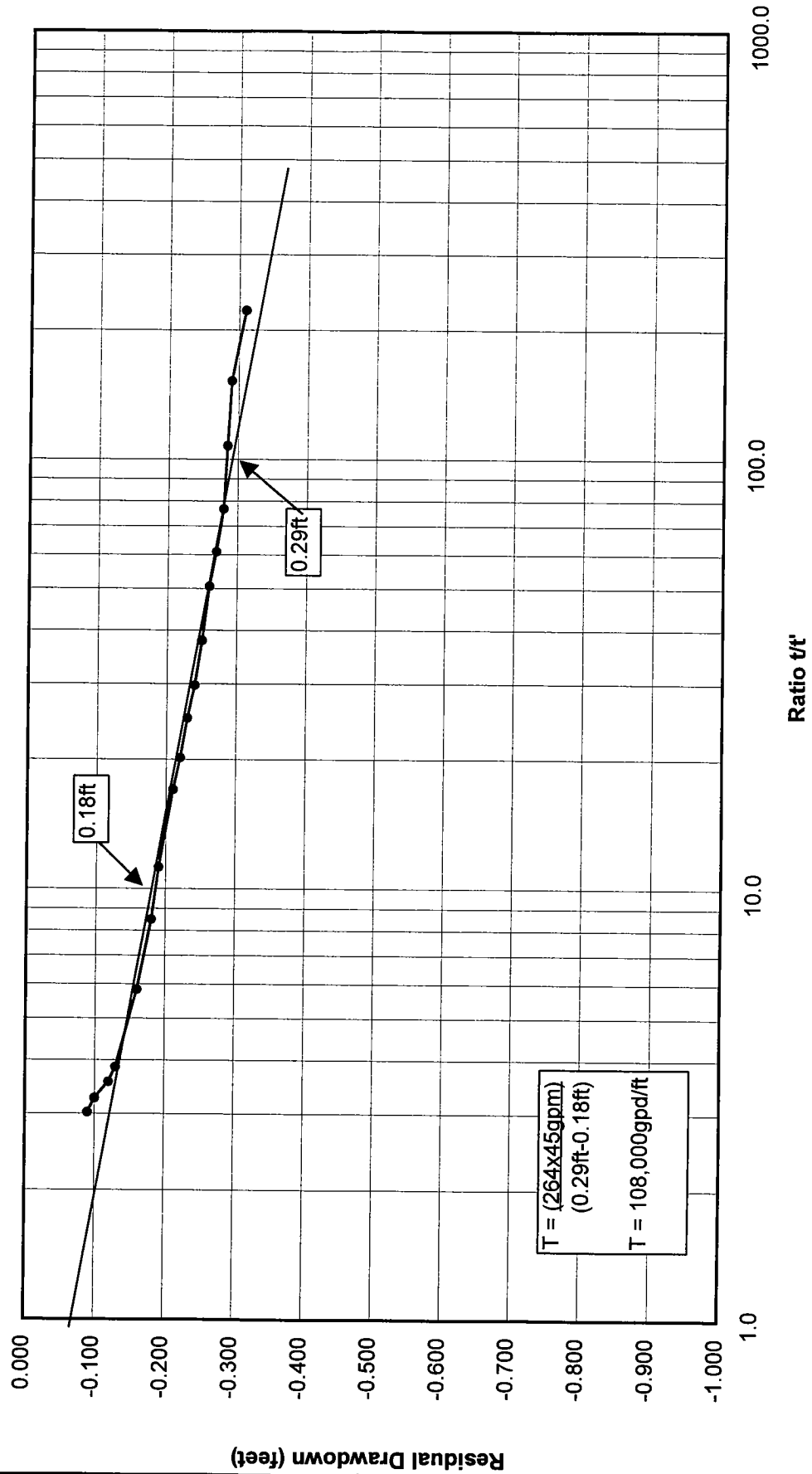

**CALCULATION OF AQUIFER COEFFICIENTS FOR OBSERVATION WELL PC-18
CONSTANT DISCHARGE PUMPING TEST
OF PITTMAN LATERAL TEST WELL PC-70**

Jacobs Semi-Log Straight-Line Analysis of Drawdown Data

Transmissivity = 40,966 gallons per day per foot
Permeability = 1,241 gallons per day per square foot
(40,966/33 feet of saturation)
Hydraulic Conductivity = 166 feet per day (1241/7.48gallons per cubic foot)
Storage Coefficient = 0.03

Theis Log-Log Type Curve Match Analysis of Drawdown Data

Transmissivity = 54,282 gallons per day per foot
Permeability = 1,645 gallons per day per square foot
(54282/33 feet of saturation)
Hydraulic Conductivity = 220 feet per day (1645/7.48gallons per cubic foot)
Storage Coefficient = 0.08

Boulton Log-Log Delayed Drainage Curve Match Analysis of Drawdown Data

Transmissivity = 53,714 gallons per day per foot
Permeability = 1,628 gallons per day per square foot
(53714/33 feet of saturation)
Hydraulic Conductivity = 218 feet per day (1628/7.48gallons per cubic foot)
Storage Coefficient = 0.09

Jacobs Semi-Log Straight-Line Analysis of Recovery Data

Transmissivity = 108,000 gallons per day per foot
Permeability = 3,273 gallons per day per square foot
(108000/33 feet of saturation)
Hydraulic Conductivity = 438 feet per day (3273/7.48gallons per cubic foot)

OB WELL PC-55

ADDENDUM G

**Tabulations and Graphs of Drawdown and Recovery Data and
Calculations of Aquifer Coefficients for Test Well PC-55**

**Recovery Data for Observation Well PC-55
 Constant Discharge Test of Henderson Well PC-70
 Kerr-McGee Henderson Facility, Henderson, NV
 Test Date: September 14-17, 1998**

Pre-Test Water Level: 17.87 feet below top of casing
 Pumping Rate: 45gpm

Date	24 Hour Clock Time	Time Since Pump Test Started (t, minutes)	Time Since Pump Stopped (t', minutes)	Ratio t/t'	Depth to Water (feet)	Residual Drawdown (s', feet)	Remarks
9/16/98	1500	2880	0.0	288000.0	18.230	0.360	Pump Off Recovery
	1515	2895	15.0	193.0	18.160	0.290	
	1522	2902	22.0	131.9	18.160	0.290	
	1528	2908	28.0	103.9	18.160	0.290	
	1539	2919	39.0	74.8	18.150	0.280	
	1549	2929	49.0	59.8	18.140	0.270	
	1559	2939	59.0	49.8	18.130	0.260	
	1619	2959	79.0	37.5	18.120	0.250	
	1640	2980	100.0	29.8	18.110	0.240	
	1700	3000	120.0	25.0	18.115	0.245	
	1730	3030	150.0	20.2	18.100	0.230	
	1800	3060	180.0	17.0	18.090	0.220	
	1930	3120	240.0	13.0	18.080	0.210	
	2100	3240	360.0	9.0	18.070	0.200	
9/17/98	2400	3420	540.0	6.3	18.050	0.180	End of Test
	0500	3720	840.0	4.4	18.020	0.150	
	0700	3840	960.0	4.0	18.010	0.140	
	1000	4020	1140.0	3.5	17.980	0.110	
	1210	4150	1270.0	3.3	17.960	0.090	

ARITHMETIC PLOT OF DRAWDOWN AND RECOVERY DATA
FOR OBSERVATION WELL PC-55
CONSTANT DISCHARGE TEST OF HENDERSON MONITOR WELL PC-70
Date of Test: September 14-17, 1998

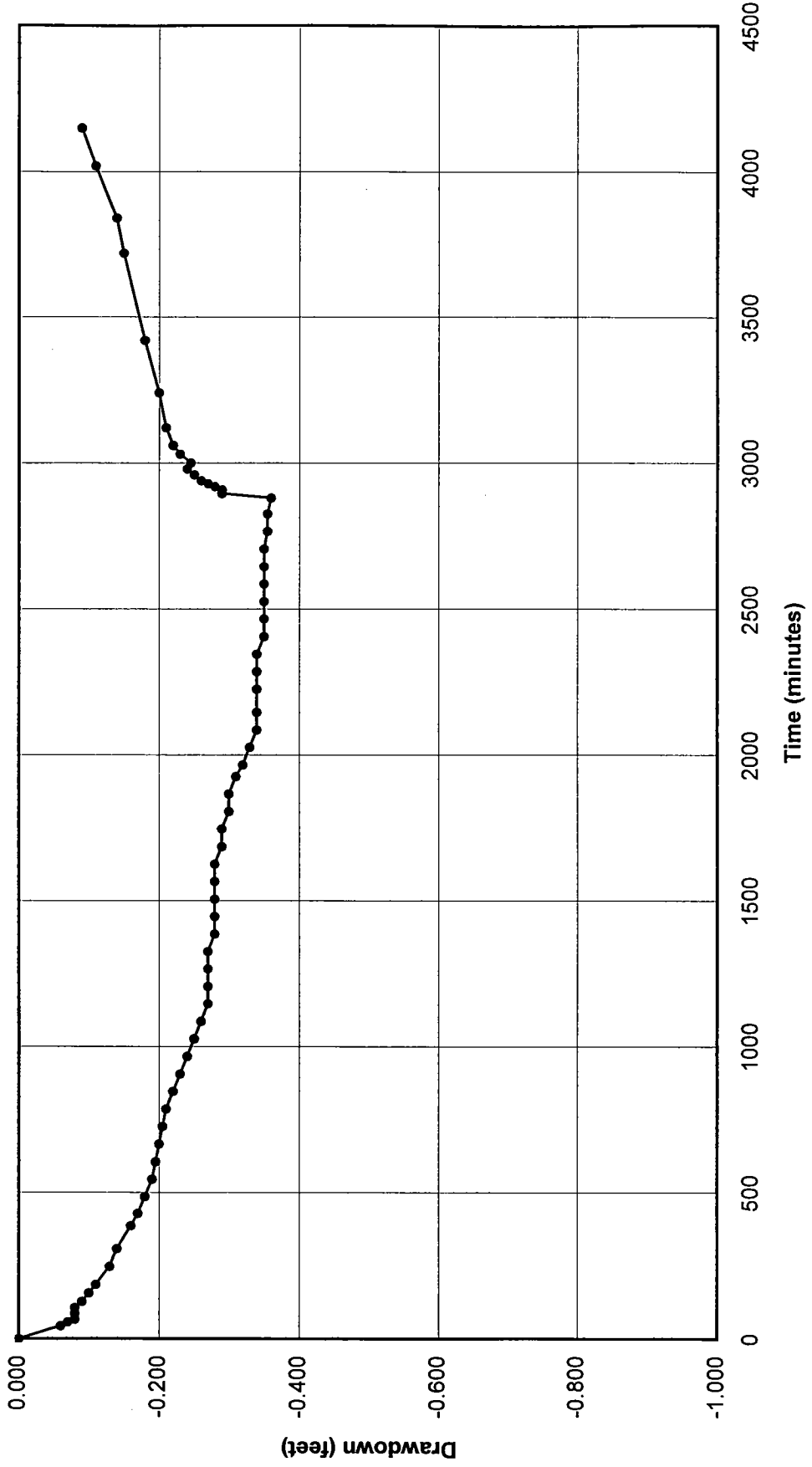

**JACOBS SEMI-LOG ANALYSIS OF TIME vs DRAWDOWN
 FOR OBSERVATION WELL PC-55
 CONSTANT DISCHARGE PUMPING TEST OF HENDERSON TEST WELL PC-70
 Date of Test: September 14-17, 1998**

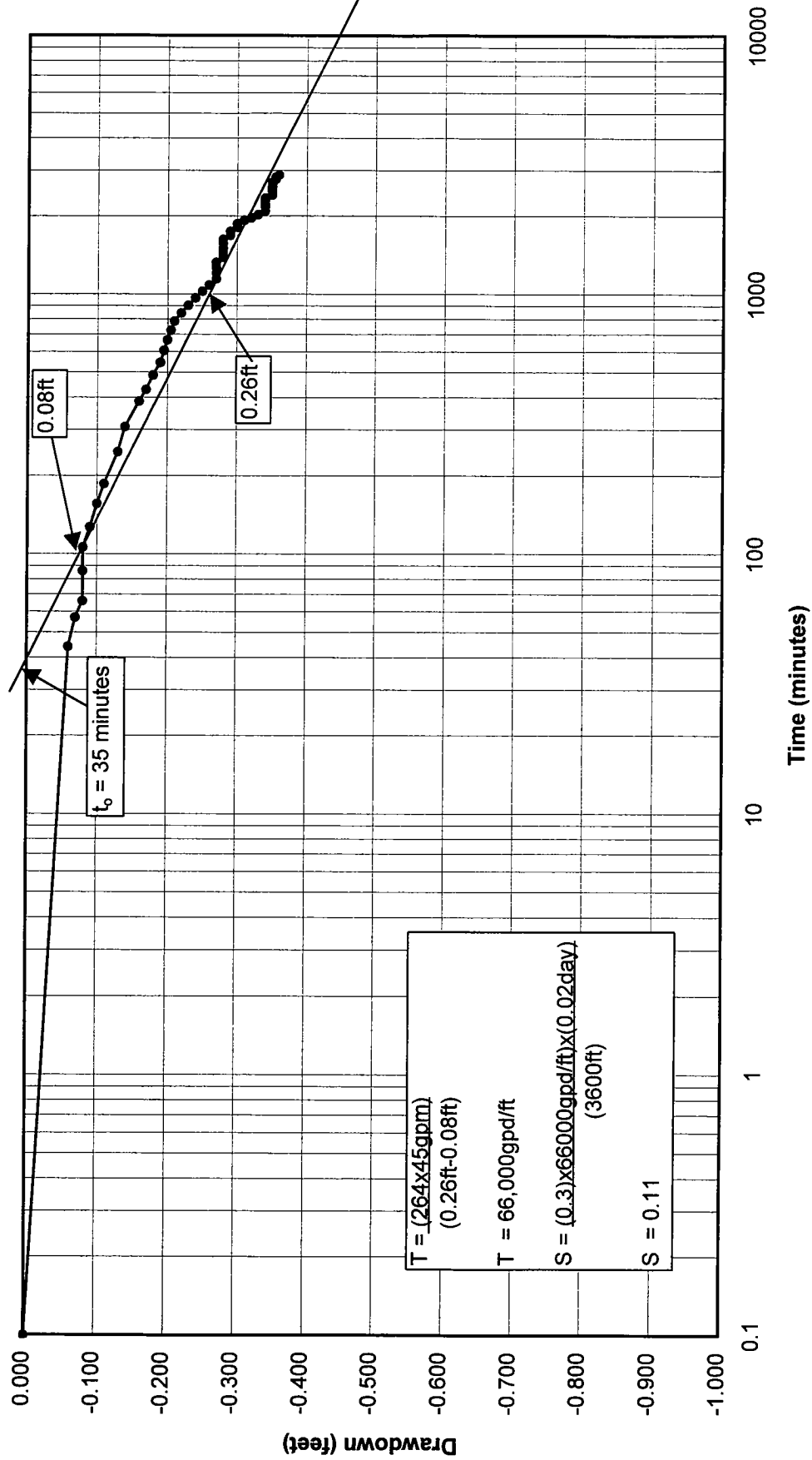

THEIS TYPE-CURVE ANALYSIS
LOG-LOG PLOT OF TIME vs DRAWDOWN FOR OBSERVATION WELL PC-55
CONSTANT DISCHARGE PUMPING TEST OF HENDERSON TEST WELL PC-70

Date of Test: September 14-17, 1998

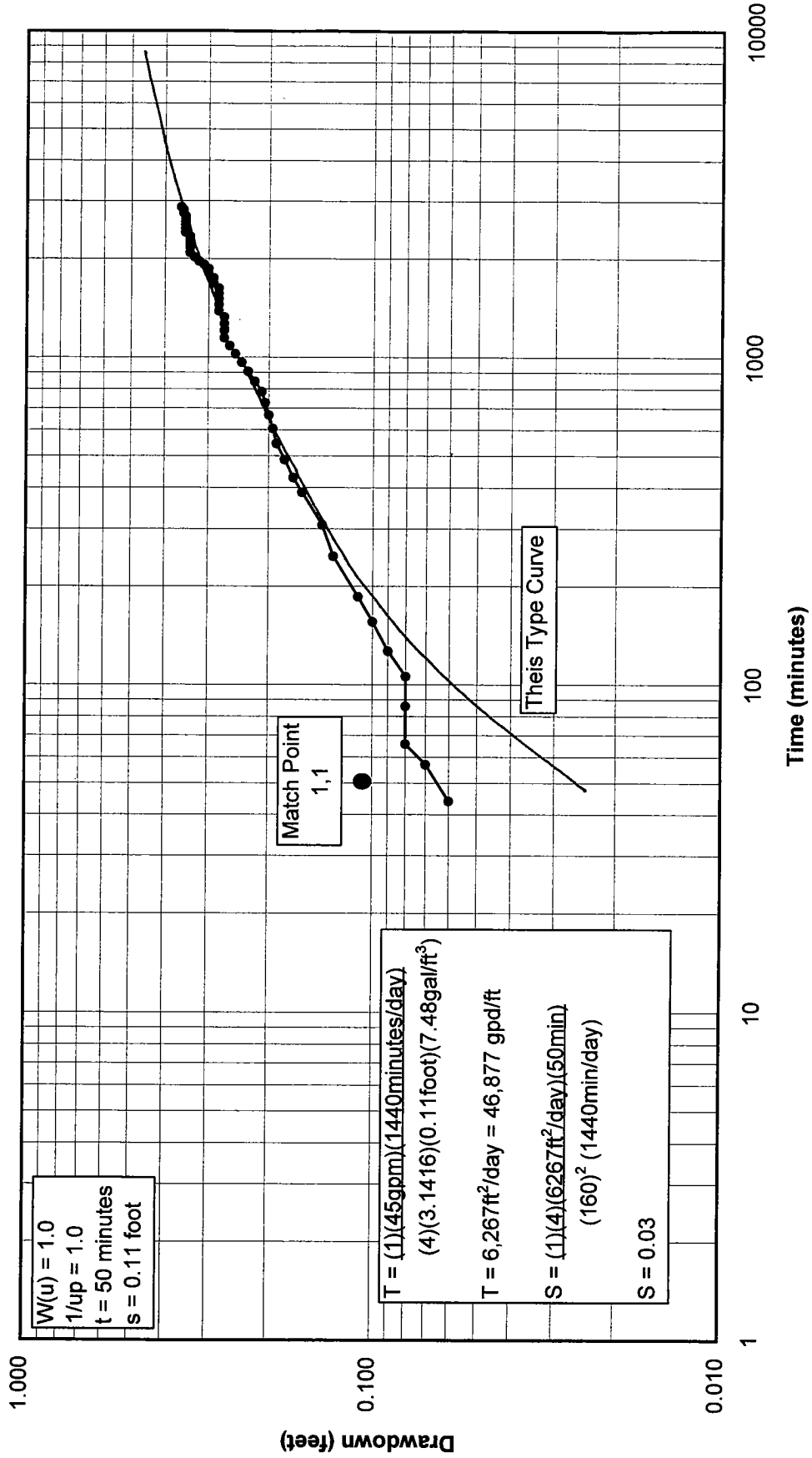

**BOULTON DELAYED DRAINAGE ANALYSIS
LOG-LOG PLOT OF TIME vs DRAWDOWN FOR OBSERVATION WELL PC-55
CONSTANT DISCHARGE PUMPING TEST OF HENDERSON TEST WELL PC-70**

Date of Test: September 14-17, 1998

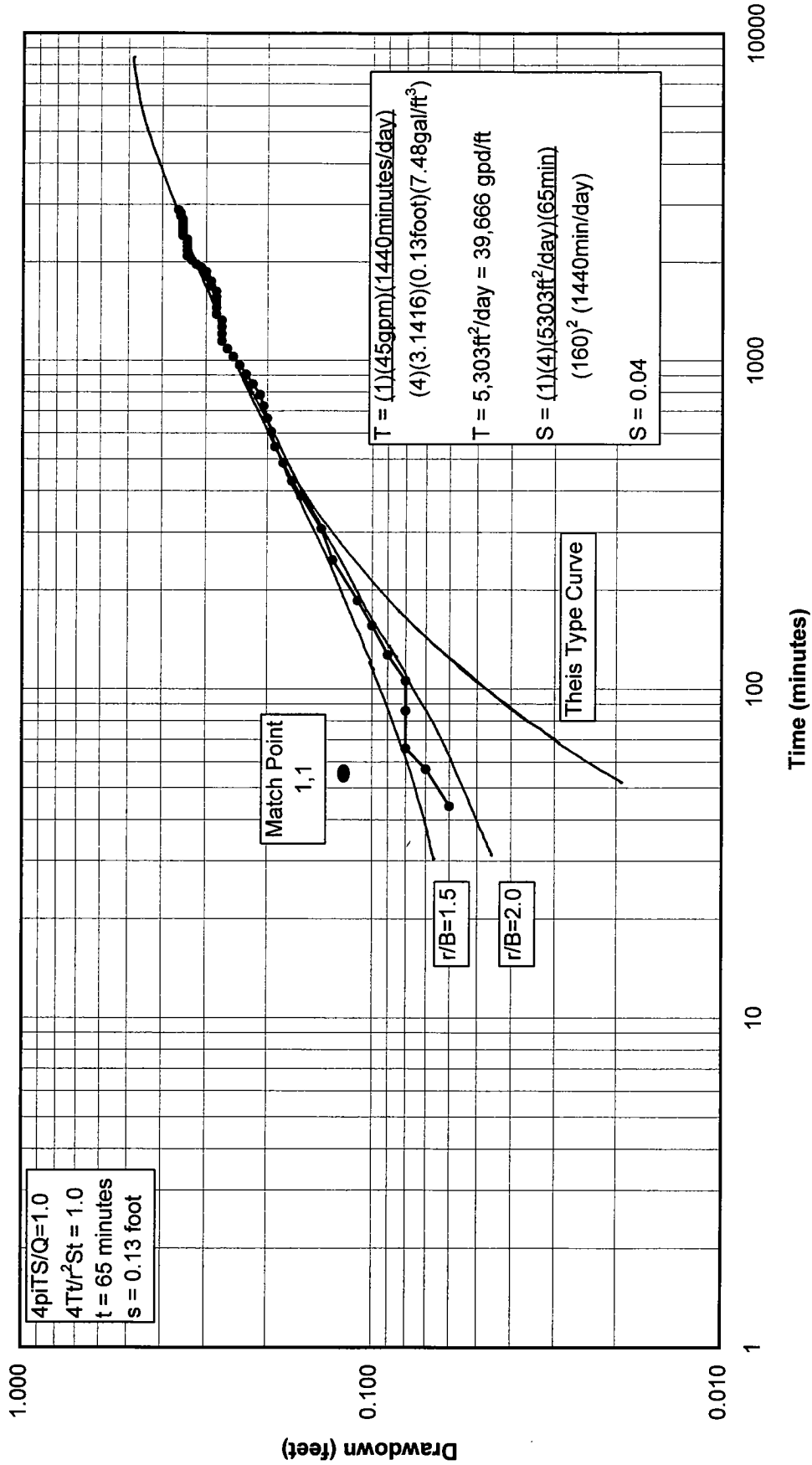

**JACOBS SEMI-LOG ANALYSIS OF t/t' vs RESIDUAL DRAWDOWN DATA
FOR OBSERVATION WELL PC-55
CONSTANT DISCHARGE RECOVERY TEST OF HENDERSON TEST WELL PC-70
Date of Recovery Test: September 16-17, 1998**

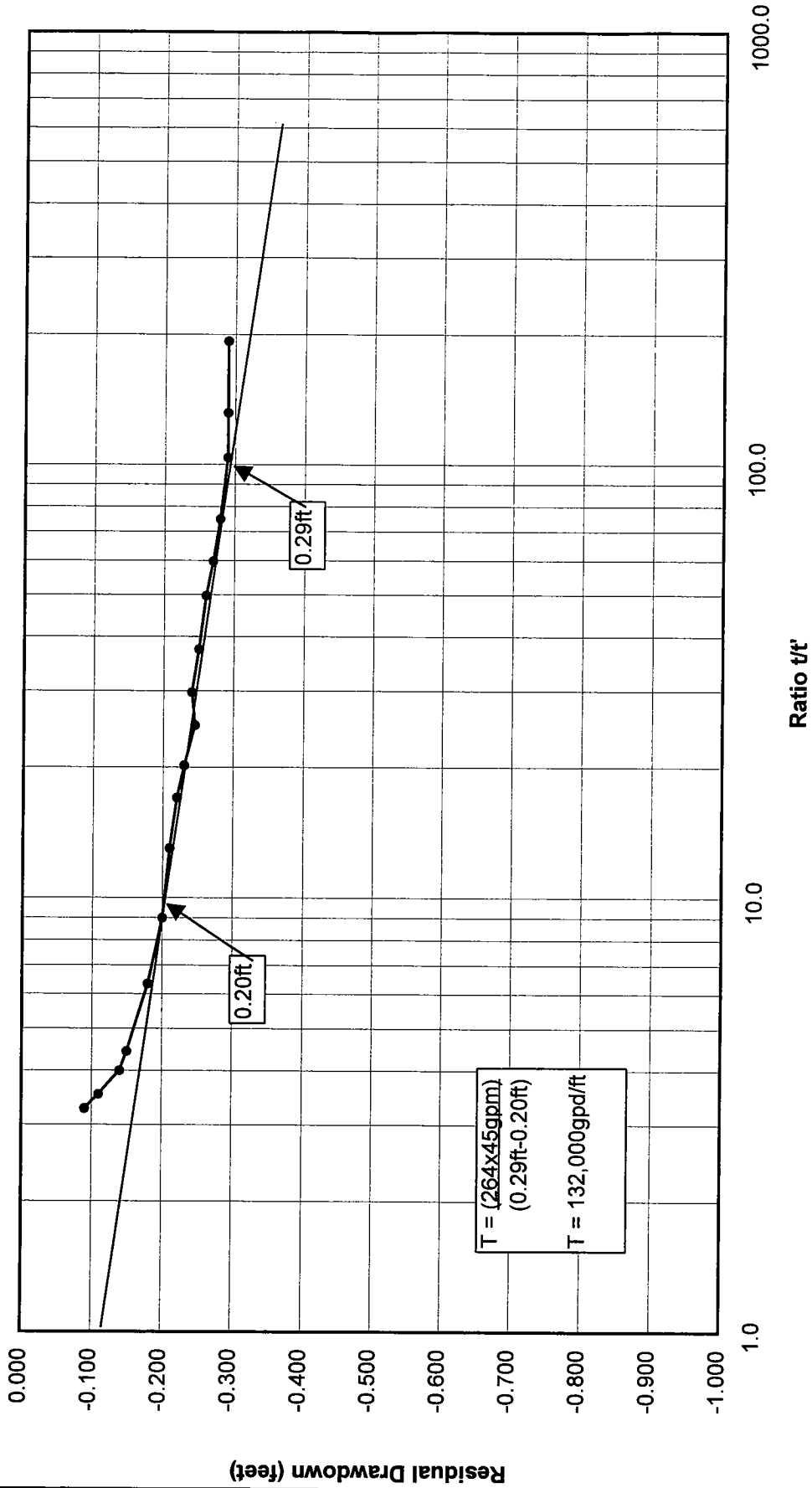

**CALCULATION OF AQUIFER COEFFICIENTS FOR OBSERVATION WELL PC-55
CONSTANT DISCHARGE PUMPING TEST
OF PITTMAN LATERAL TEST WELL PC-70**

Jacobs Semi-Log Straight-Line Analysis of Drawdown Data

Transmissivity = 66,000 gallons per day per foot
Permeability = 1,748 gallons per day per square foot
(66,000/33 feet of saturation)
Hydraulic Conductivity = 239 feet per day (1748/7.48gallons per cubic foot)
Storage Coefficient = 0.11

Theis Log-Log Type Curve Match Analysis of Drawdown Data

Transmissivity = 46,877 gallons per day per foot
Permeability = 1,267 gallons per day per square foot
(46877/37 feet of saturation)
Hydraulic Conductivity = 169 feet per day (1287/7.48gallons per cubic foot)
Storage Coefficient = 0.03

Boulton Log-Log Delayed Drainage Curve Match Analysis of Drawdown Data

Transmissivity = 39,666 gallons per day per foot
Permeability = 1,072 gallons per day per square foot
(39666/37 feet of saturation)
Hydraulic Conductivity = 143 feet per day (1072/7.48gallons per cubic foot)
Storage Coefficient = 0.04

Jacobs Semi-Log Straight-Line Analysis of Recovery Data

Transmissivity = 132,000 gallons per day per foot
Permeability = 3,568 gallons per day per square foot
(132000/37 feet of saturation)
Hydraulic Conductivity = 477 feet per day (3568/7.48gallons per cubic foot)

DISTANCE-DRAWDOWN

ADDENDUM H

Graphs of Distance-Drawdown Analyses and Calculations of Corresponding Aquifer Coefficients

**DISTANCE-DRAWDOWN ANALYSIS OF DRAWDOWN DATA
AFTER 100 MINUTES OF PUMPING
CONSTANT DISCHARGE TEST OF HENDERSON TEST WELL PC-70
Date of Test: September 14-17, 1998**

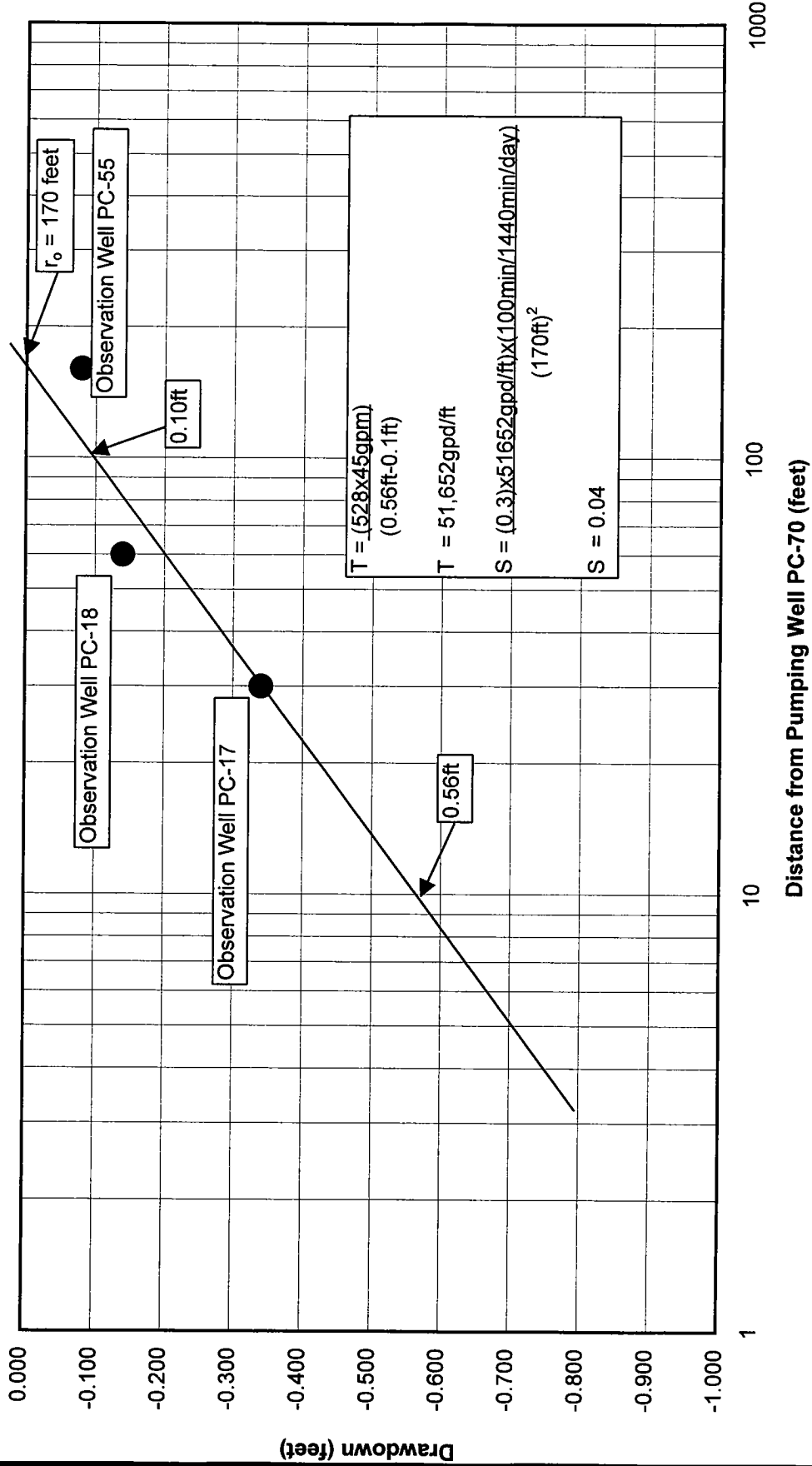

**DISTANCE-DRAWDOWN ANALYSIS OF DRAWDOWN DATA
AFTER 720 MINUTES (12 HOURS) OF PUMPING
CONSTANT DISCHARGE TEST OF HENDERSON TEST WELL PC-70
Date of Test: September 14-17, 1998**

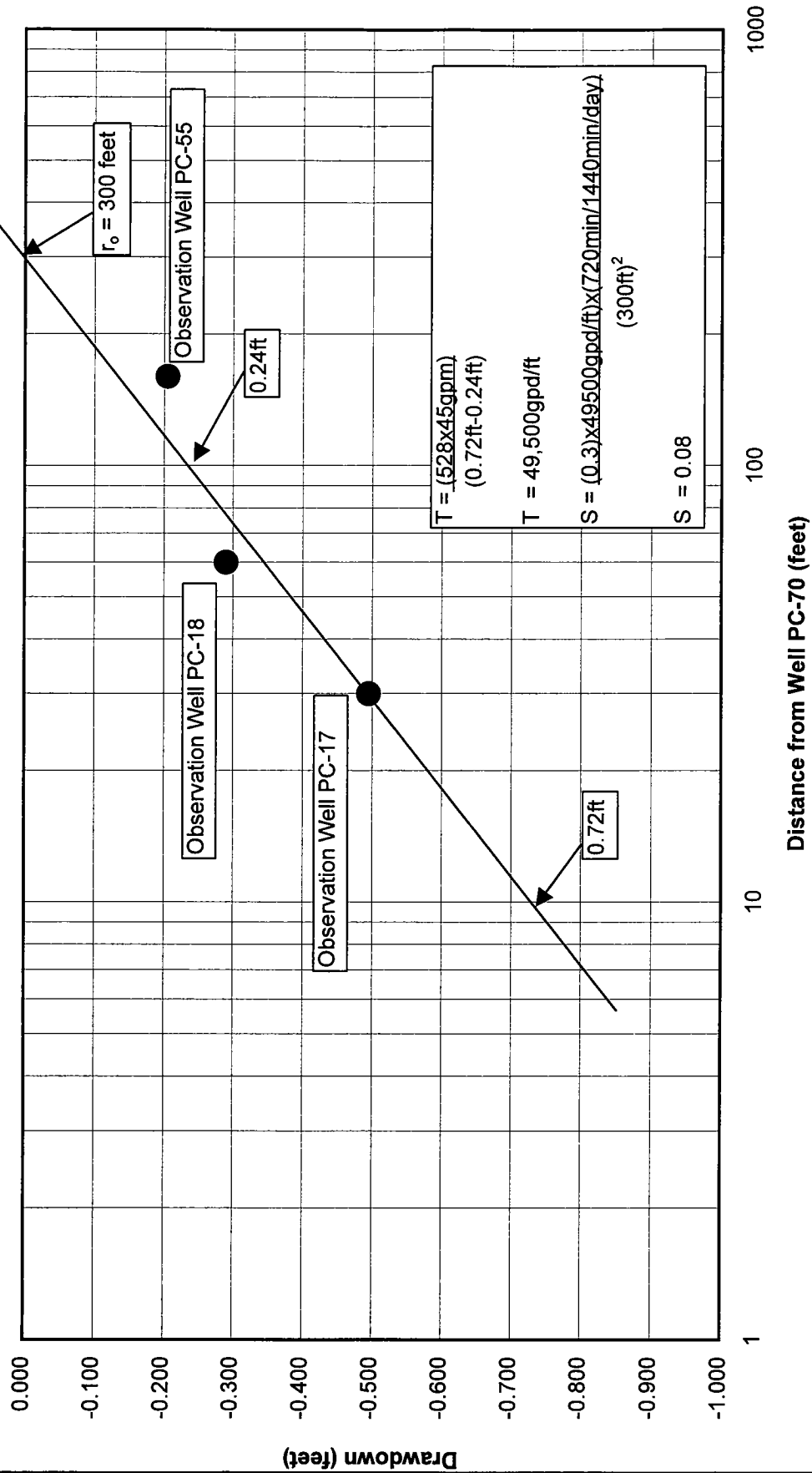

**DISTANCE-DRAWDOWN ANALYSIS OF DRAWDOWN DATA
AFTER 1440 MINUTES (24 HOURS) OF PUMPING
CONSTANT DISCHARGE TEST OF HENDERSON TEST WELL PC-70
Date of Test: September 14-17, 1998**

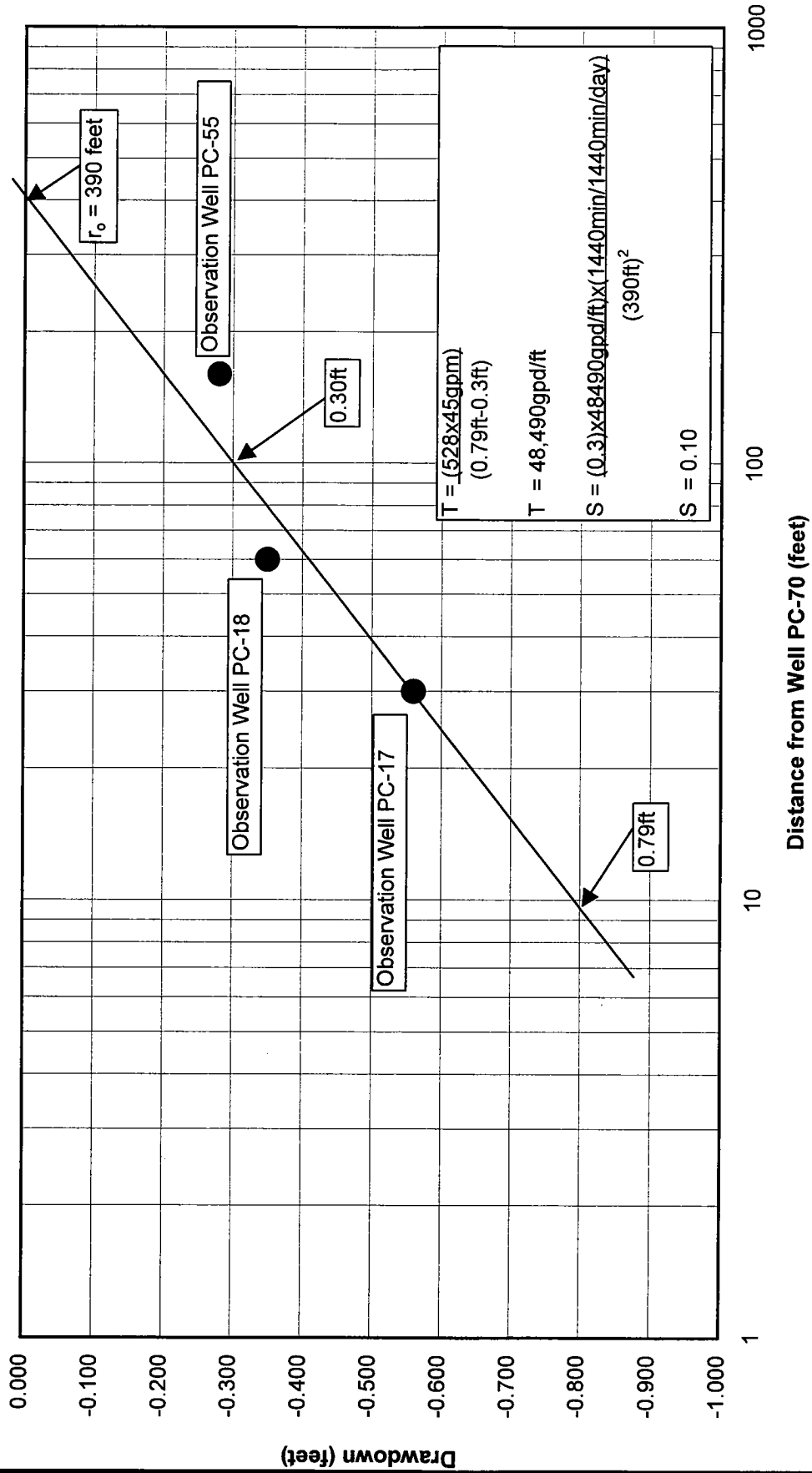

**DISTANCE-DRAWDOWN ANALYSIS OF DRAWDOWN DATA
AFTER 2160 MINUTES (36 HOURS) OF PUMPING
CONSTANT DISCHARGE TEST OF HENDERSON TEST WELL PC-70
Date of Test: September 14-17, 1998**

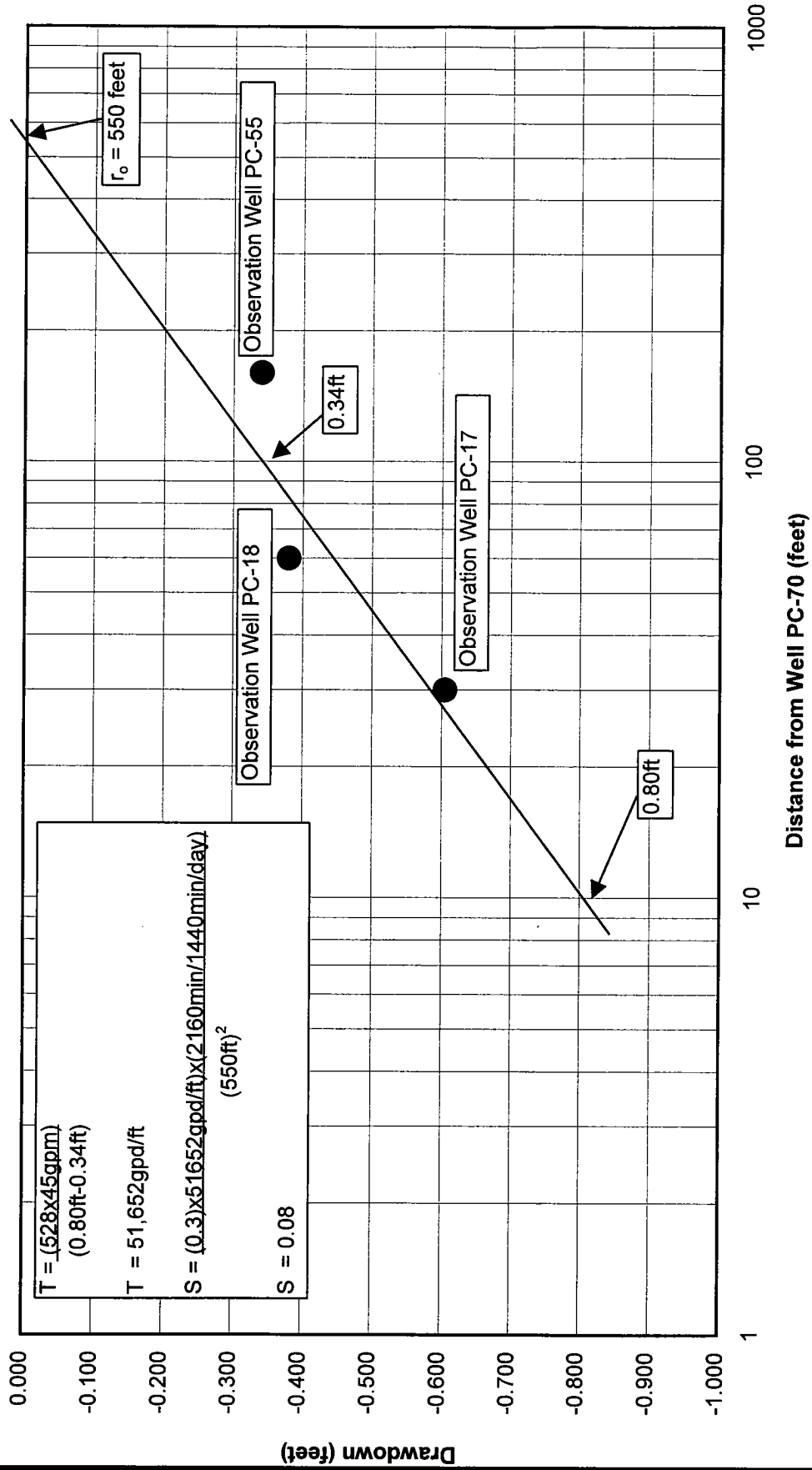

**DISTANCE-DRAWDOWN ANALYSIS OF DRAWDOWN DATA
AFTER 2880 MINUTES (48 HOURS) OF PUMPING
CONSTANT DISCHARGE TEST OF HENDERSON TEST WELL PC-70
Date of Test: September 14-17, 1998**

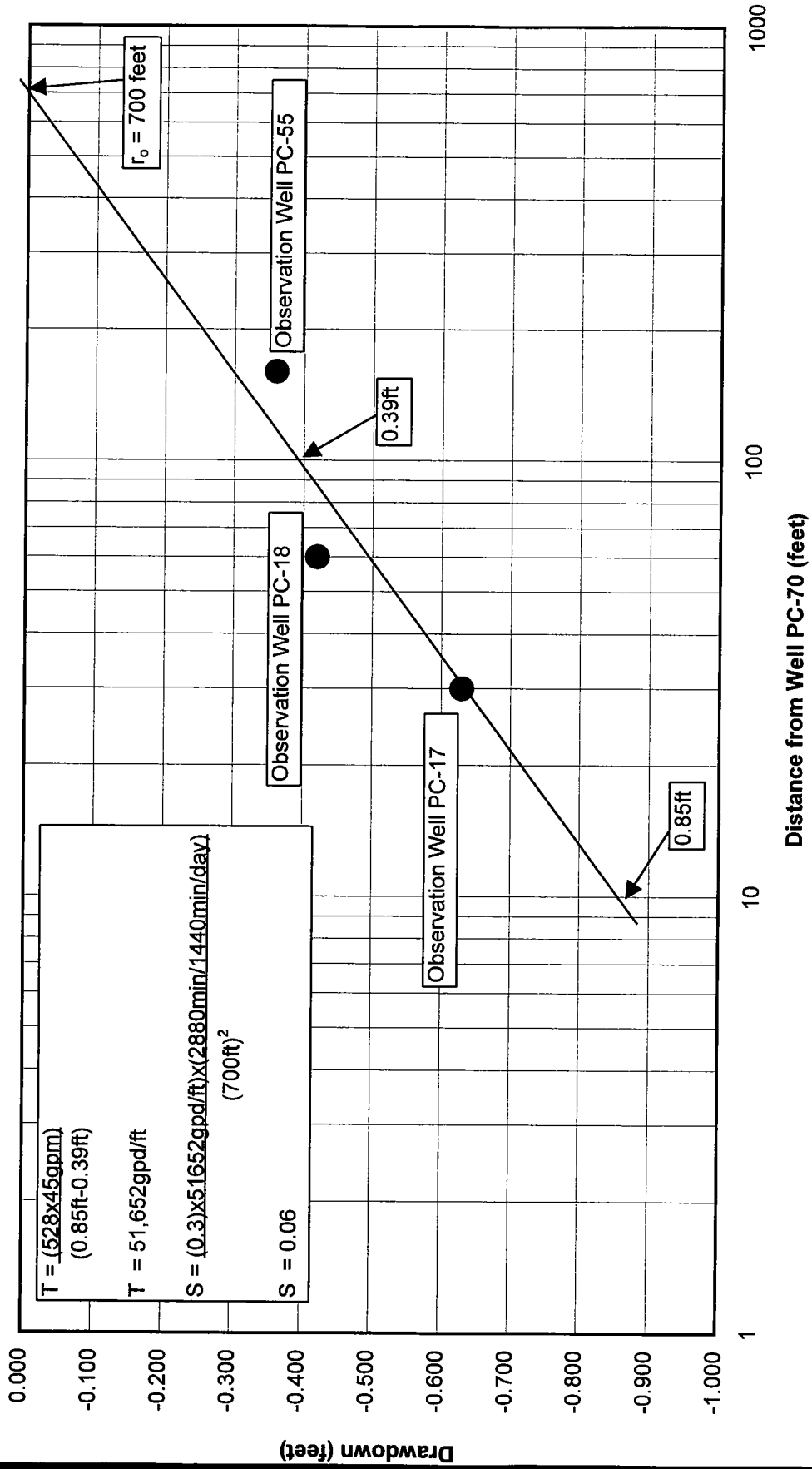

**CALCULATION OF AQUIFER COEFFICIENTS
FROM DISTANCE DRAWDOWN DATA
CONSTANT DISCHARGE PUMPING TEST
OF PITTMAN LATERAL TEST WELL PC-70**

Jacobs Semi-Log Straight-Line Analysis of Distance-Drawdown Data at 100 Minutes

Transmissivity = 51,652 gallons per day per foot
Permeability = 1,519 gallons per day per square foot
(51652/34 feet of average saturation)
Hydraulic Conductivity = 203 feet per day (1519/7.48gallons per cubic foot)
Storage Coefficient = 0.04

Jacobs Semi-Log Straight-Line Analysis of Distance-Drawdown Data at 720 Minutes

Transmissivity = 49,500 gallons per day per foot
Permeability = 1,456 gallons per day per square foot
(49500/34 feet of average saturation)
Hydraulic Conductivity = 195 feet per day (1456/7.48gallons per cubic foot)
Storage Coefficient = 0.08

Jacobs Semi-Log Straight-Line Analysis of Distance-Drawdown Data at 1440 Minutes

Transmissivity = 48,490 gallons per day per foot
Permeability = 1,426 gallons per day per square foot
(48490/34 feet of average saturation)
Hydraulic Conductivity = 191 feet per day (1426/7.48gallons per cubic foot)
Storage Coefficient = 0.10

Jacobs Semi-Log Straight-Line Analysis of Distance-Drawdown Data at 2160 Minutes

Transmissivity = 51,652 gallons per day per foot
Permeability = 1,519 gallons per day per square foot
(51,652/34 feet of average saturation)
Hydraulic Conductivity = 203 feet per day (1519/7.48gallons per cubic foot)
Storage Coefficient = 0.08

**CALCULATION OF AQUIFER COEFFICIENTS
FROM DISTANCE DRAWDOWN DATA
CONSTANT DISCHARGE PUMPING TEST
OF PITTMAN LATERAL TEST WELL PC-70
(continued)**

Jacobs Semi-Log Straight-Line Analysis of Distance-Drawdown Data at 2880 Minutes

Transmissivity = 51,652 gallons per day per foot

Permeability = 1,519 gallons per day per square foot

(51,652/34 feet of average saturation)

Hydraulic Conductivity = 203 feet per day (1519/7.48gallons per cubic foot)

Storage Coefficient = 0.08

WELL EFFICIENCY

100%

90%

80%

70%

60%

ADDENDUM I

Projection of Well Efficiency for Test Well PC-70

**SEMI-LOG PLOT OF DISTANCE-DRAWDOWN AT WELLS PC-17 AND PC-18
PROJECTING THE EFFICIENCY OF TEST WELL PC-70 AT 48 HOURS
CONSTANT DISCHARGE TEST OF HENDERSON TEST WELL PC-70**

Date of Test: September 14-17, 1998

